



## ENGINE

Model	F5HFL463A*G032
Emissions Certification	Tier 4 Final
Type	Diesel 4-stroke, Turbo, D.I.
Cylinders	4
Bore/Stroke	3.9 x 4.3 in (99 x 110 mm)
Displacement	207 in <sup>3</sup> (3.4 L)
Fuel injection	Direct, high pressure common rail – HPCR
Fuel	#2 Diesel
Fuel filter:	
Pre-filter	Beta (30) = 200/spin-on
Main filter	Beta (4) = 20/spin-on
Air intake	Turbocharged w/ waste gate and external cooled EGR
Exhaust aftertreatment	Diesel Oxidation Catalyst (DOC)
Cooling	Liquid
Engine speeds	RPM
High idle – no load	2,500 +/- 25
Rated – full load	2,500
Low idle	1,150 +/- 25
Horsepower @ 2,500 RPM – SAE J1349:	
Gross	74 hp (55 kW)
Net	68 hp (51 kW)
Peak torque @ 1,400 RPM	232 lb-ft (314 N·m)
Radiator:	
Core type	All aluminum
Core size area	2.77 ft <sup>2</sup> (.257 m <sup>2</sup> )
Rows of tubes x columns	43 x 3
Cap pressure	16 +/- 2 psi (1.10 +/- 0.14 bar)
Fan:	
Diameter	20.4 in (518 mm)
Ratio	0.96:1 standard, 1.1:1 high-flow
Water pump:	
Style	Centrifugal
Flow	29 gpm (110 L/min)
Engine lubrication pump:	
Rotor pump w/ deep sump pan, plate cooler and pressurized under-piston nozzles	
Pump operating angle ratings:	
Side to side	45°
Bucket up	35°
Bucket down	45°

## LIFT GEOMETRY

Radial lift

## DRIVETRAIN

Drive pump controls	Servo-assist mechanical
Pump to engine ratio	1:1
Displacement	2.81 in <sup>3</sup> (46 cm <sup>3</sup> )
Flow @ rated engine RPM:	
@ 97% efficiency	29.4 gpm (111 L/min)
Charge pressure	360 psi (24.5 bar)
System relief pressure	5,220 psi (360 bar)
Drive pump controls	Electro-hydraulic
Pump to engine ratio	1:1
Displacement	2.75 in <sup>3</sup> (45 cm <sup>3</sup> )
Flow @ rated engine RPM:	
@ 97% efficiency	28.8 gpm (109 L/min)
Charge pressure	362 psi (24.5 bar)
System relief pressure	5,220 psi (360 bar)
Drive motors:	
Max. displacement	3.1 in <sup>3</sup> (50.9 cm <sup>3</sup> )
Displacement:	
High speed	2.02 in <sup>3</sup> (33.1 cm <sup>3</sup> )
Motor RPM @ high idle and 97% efficiency:	
2-speed	156
Motor torque @ max. displacement and relief pressure, calculated @ 5,220 psi (360 bar):	4,654 lb-ft (6 310 N·m)
Travel speed:	
Low range	5.1 mph (8.2 kph)
High range	8 mph (12.9 kph)
Final drive:	
Planetary gearbox w/ 2-speed motor	
Tractive effort	7,414 lb (3 370 kg)
Parking brake:	
Type	Spring-applied, hydraulic release multiple disc.
Engagement	Depress on/off brake button on handle or instrument panel, raise seat bar, get off seat or stop engine.

## ELECTRICAL

Alternator	120 amp
Starter	4.29 hp (3.2 kW)
Battery	12-volt low-maintenance 925 cold-cranking amps @ 0° F (-18° C)

## OPERATOR ENVIRONMENT

ROPS/FOPS Level 1 canopy w/ side screens; Keyed start ignition; Tilt ROPS/FOPS; Rear window w/ emergency escape; Suspension seat, vinyl w/ 2 in (51 mm) retractable 3 point lap seat belt; Hand and foot throttles; Alarm package – back-up and horn; Rearview mirror; Headliner; Dome light; Top window; Cup holder; 12V Power plug socket; Foot rest; Seat pocket; Padded seat bar w/ integral armrests; Loader control lockout system; Electric parking brake control; Operator's compartment floor cleanout; Proportional

auxiliary hydraulic control – on joystick; Advanced instrument cluster w/ digital hour meter, tachometer, Fuel level LCD bar graph w/ alarm, diagnostic features and security lockout.

Warning lights w/ alarms:

Engine coolant temperature; Engine oil pressure; Engine malfunction; Hydraulic charge pressure; Hydraulic filter restriction; Hydraulic oil temperature: Critical system stop, Engine system, Hydraulic system, Electrical and diagnostic system.

Warning alarms:

Battery voltage – plus display; Oil service.

Indicator light:

Engine preheat; Parking brake;  
Seat bar reminder.

## OPERATING WEIGHT

Unit equipped w/ open cab; 165 lb operator; 72 in Dirt and Foundry bucket; full of fuel:	8,270 lb (3 750 kg)
Shipping weight	7,970 lb (3 615 kg)
Add-on weights:	
Side cab glass	47 lb (21.3 kg)
Polycarbonate cab door	74 lb (33.6 kg)
Glass cab door w/ wiper	134 lb (60.8 kg)
Suspension seat	22 lb (10 kg)
Additional counterweight	140 lb (63.8 kg)

## HYDRAULICS

Implement pump type	Gear
Displacement:	
Standard aux.	2.23 in <sup>3</sup> (36.6 cm <sup>3</sup> )
High-flow aux.	76 in <sup>3</sup> (12.5 cm <sup>3</sup> )
Standard flow @ rated engine RPM: @ 100% efficiency	24.2 gpm (91.5 L/min)
Optional high-flow @ rated engine RPM: @ 100% efficiency	32.4 gpm (122.6 L/min)
Loader control valve:	
Type	3 spool/open center/series – series
Relief pressure	3,050 psi (210 bar)
Port relief pressures:	
Loader raise	3,263 psi (225 bar)
Bucket curl	3,770 psi (260 bar)
Bucket dump	1,160 psi (80 bar)
Hydraulic lines:	
Tubing	37° JIC Flare
Loop hoses	SAE 100 R19
Hydraulic oil cooler:	
Number of fins	10 per in (3.94 per cm)
Number of tube rows x columns	9 x 1
Area	136.5 in <sup>2</sup> (880 cm <sup>2</sup> )
Hydraulic filter	Beta (4) = 75/spin-on

## HYDRAULICS CONT.

Lift cylinders:	
Bore diameter	2.5 in (63.5 mm)
Rod diameter	1.75 in (44.5 mm)
Stroke	31.69 in (804.9 mm)
Closed length	45.59 in (1 158 mm)
Bucket cylinders:	
Bore diameter	2.75 in (69.9 mm)
Rod diameter	1.38 in (34.9 mm)
Stroke	16.14 in (410 mm)
Closed length	24.02 in (610 mm)

## SERVICE CAPACITIES

Fuel tank	19.5 gal (73.8 L)
Engine oil w/ filter	10 qt (9.4 L)
Hydraulic system:	
Reservoir	7 gal (26.5 L)
Total	8.5 gal (32.2 L)

## PERFORMANCE SPECS

Rated operating capacity – ROC*:	
35% of tipping load	1,890 lb (860 kg)
50% of tipping load	2,700 lb (1 225 kg)
w/ additional counterweight	2,800 lb (1 270 kg)
Tipping load*	5,400 lb (2 449 kg)
Breakout forces @ 3,150 psi (217 bar)*:	
Bucket cylinders	7,270 lb (32.3 kN)
Lift cylinders – hydraulic limit	6,260 lb (27.8 kN)
Cycle times:	
Raise	3.6 sec
Lower	1.8 sec
Dump	2.2 sec
Roll back	1.7 sec

NOTE: \*Measured using 72 in (1.83 m) foundry/ excavating bucket.

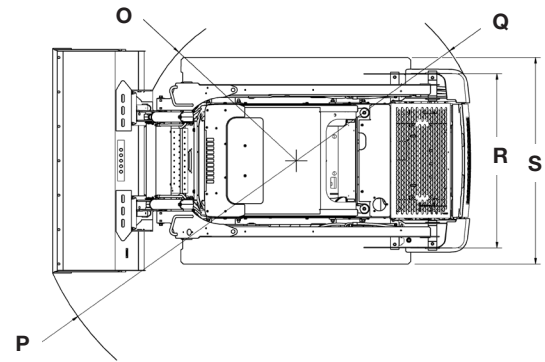
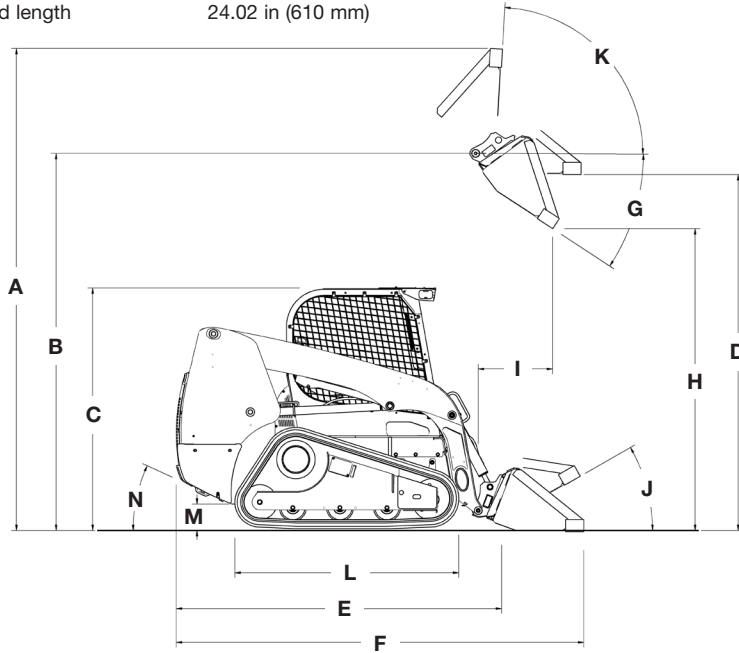

Line drawings are for illustrative purpose only and may not be exact representation of unit.

## DIMENSIONS

<b>A.</b> Overall operating height:	
w/ foundry/excavating bucket	155.6 in (3.95 m)
w/ low profile bucket	159.8 in (4.06 m)
w/ low profile extended bucket	164.6 in (4.18 m)
Height to:	
<b>B.</b> Bucket hinge pin	125.1 in (3.18 m)
<b>C.</b> Top of ROPS	78.7 in (2 m)
<b>D.</b> Bottom of level bucket, fully raised	117.7 in (2.98 m)
Overall length:	
<b>E.</b> w/o attachment w/ coupler	104.8 in (2.66 m)
<b>F.</b> w/ foundry/excavating bucket on ground	129.1 in (3.28 m)
w/ low profile bucket	133.4 in (3.39 m)
w/ low profile extended bucket	138.3 in (3.51 m)
<b>G.</b> Maximum dump angle	38.1°
<b>H.</b> Dump height:	
w/ foundry/excavating bucket	100.6 in (2.56 m) @ 38.1°
w/ low profile bucket	98 in (2.49 m) @ 38.1°
<b>I.</b> Dump reach at maximum height w/ low profile bucket	25.6 in (.65 m) @ 38.1°
Maximum attachment rollback:	
<b>J.</b> Bucket on ground	31°
<b>K.</b> Bucket at full height	99.9°
<b>L.</b> Track on ground	55.9 in (1.42 m)
<b>M.</b> Ground clearance – bottom of belly pan	8 in (.2 m)
<b>N.</b> Angle of departure	32°
Clearance circle:	
<b>O.</b> w/o bucket	52.3 in (1.35 m)
<b>P.</b> w/ 72 in (1.83 m) foundry/excavating bucket in carry position	82.2 in (2.19 m)
w/ 72 in (1.83 m) low profile bucket on ground	85.8 in (2.18 m)
w/ 72 in (1.83 m) extended low profile on ground	90.4 in (2.29 m)
<b>Q.</b> Clearance circle rear	59.9 in (1.52 m)
<b>R.</b> Track gauge	53.4 in (1.36 m)
<b>S.</b> Over the track width	65.9 in (1.68 m)

## TRACK SELECTION

Type	Area	Ground Pressure	Width to Outside Track
12.6 in (320 mm)	1,408 in <sup>2</sup> (91 m <sup>2</sup> )	5.9 psi (40.5 kPa)	65.9 in (1.68 m)

## OPTIONAL BUCKETS

Type	Width	Weight	Heaped Capacity
Dirt and Foundry	72 in (1.83 m)	420 lb (190 kg)	16.2 ft <sup>3</sup> (.46 m <sup>3</sup> )
	78 in (1.98 m)	440 lb (200 kg)	17.7 ft <sup>3</sup> (.5 m <sup>3</sup> )
Low Profile	72 in (1.83 m)	480 lb (218 kg)	14.8 ft <sup>3</sup> (.42 m <sup>3</sup> )
Low Profile Extended	72 in (1.83 m)	510 lb (232 kg)	17.7 ft <sup>3</sup> (.5 m <sup>3</sup> )
	78 in (1.98 m)	540 lb (245 kg)	19.1 ft <sup>3</sup> (.54 m <sup>3</sup> )
	84 in (2.13 m)	575 lb (262 kg)	20.5 ft <sup>3</sup> (.58 m <sup>3</sup> )
Light Material	72 in (1.83 m)	475 lb (216 kg)	23.3 ft <sup>3</sup> (.66 m <sup>3</sup> )
	84 in (2.13 m)	540 lb (245 kg)	27.5 ft <sup>3</sup> (.78 m <sup>3</sup> )
Manure and Slurry	72 in (1.83 m)	480 lb (218 kg)	19.1 ft <sup>3</sup> (.54 m <sup>3</sup> )
Heavy-Duty	72 in (1.83 m)	510 lb (230 kg)	14.1 ft <sup>3</sup> (.4 m <sup>3</sup> )
	78 in (1.98 m)	530 lb (240 kg)	15.5 ft <sup>3</sup> (.44 m <sup>3</sup> )
	84 in (2.13 m)	550 lb (250 kg)	17 ft <sup>3</sup> (.48 m <sup>3</sup> )
Heavy-Duty Extended w/ SmartFit™ Bucket Teeth	72 in (1.83 m)	667 lb (303 kg)	17.4 ft <sup>3</sup> (.49 m <sup>3</sup> )
	78 in (1.98 m)	697 lb (316 kg)	18.9 ft <sup>3</sup> (.54 m <sup>3</sup> )
	84 in (2.13 m)	728 lb (330 kg)	20.5 ft <sup>3</sup> (.58 m <sup>3</sup> )

## STANDARD EQUIPMENT

### OPERATOR ENVIRONMENT

See page 1

### ENGINE

F5HFL463A\*G032  
 207 CID (3.4 L) Turbo  
 Tier 4 Final Certified  
 Diesel Oxidation Catalyst (DOC)  
 High Pressure Common Rail (HPCR)  
 fuel injection  
 Horsepower:  
 Gross: 74 hp (55 kW)  
 Net: 68 hp (51 kW)  
 Peak torque: 232 lb-ft (314 N-m)  
 120 amp alternator  
 Dual element air cleaner  
 Organic Acid Technology (OAT)  
 Anti-freeze solution to -34° F  
 Fuel tank – 19.5 gal (U.S.)  
 Over and under radiator and oil cooler  
 3-stack after cooler/radiator/oil  
 cooler configuration  
 Glow plugs  
 Integral engine oil cooler  
 Fuel filter w/ water trap  
 1,000 CCA 12V battery  
 Master electrical disconnect

### DRIVETRAIN

2-speed hydrostatic  
 SAHR disc parking brake

### HYDRAULICS

Auxiliary hydraulics:  
 @ 3,050 psi (210 bar) – 24.2 gpm  
 (91.5 L/min)  
 6 micron oil filtration system  
 3-spool loader control valve  
 Auxiliary hydraulic disconnects, ISO  
 flat-face – connect-under-pressure  
 w/ case drain  
 Hydraulic circuit pedal lock  
 Auxiliary function lockout override  
 Loader lift lockout override  
 Heavy-duty hydraulic oil cooler  
 Loader arm float position  
 Loader function lockout system

### LOADER

Manual attachment coupler  
 Radial lift geometry  
 Loader lift arm support strut  
 SAE operating load: 2,700 lb  
 Tipping load: 5,400 lb

### TRACKS

Rubber tracks

### OTHER STANDARD FEATURES

LED lights – 2 front, 2 side, 2 rear flood  
 Pre-wired for rotating beacon  
 Lockable service access hood  
 Single-point daily servicing  
 Rear tail lights  
 Remote oil and fuel filters  
 Block heater  
 Debris ingress sealing  
 Mounting points for add-on counterweights

### TELEMATICS

MyCASEConstruction Telematics – Includes  
 hardware and 7-Year data subscription  
 SiteConnect module providing remote  
 diagnostics capability

## OPTIONAL EQUIPMENT

### OPERATOR ENVIRONMENT

Enclosed cab:  
Fully sealed and pressurized – FSP  
Glass door w/ wiper and washer  
Sliding side windows – removable  
Ventilation system w/ integrated heater  
Heater and air conditioner  
AM/FM Bluetooth® radio w/ 2 speakers and USB port  
Keyless start ignition  
8 in Color LCD display  
Economy mode (auto idle shutdown)  
Auto engine protection shutdown  
Electro-hydraulic controls:  
For drive/steering, loader functions  
Switchable between H and ISO patterns  
Adjustable sensitivity of controls  
Mechanical hand controls  
Hand and foot controls:  
Hand controls the loader drive function and foot controls the bucket and boom  
Deluxe cloth, air suspension seat, w/ heater and lumbar support  
Open cab interior trim package  
Demolition cab door w/ polycarbonate  
Ignition timeout  
Machine settings user access levels  
Operator security codes  
Auto idle settings

### HYDRAULICS

High-flow auxiliary hydraulics – combined:  
@ 3,050 psi (210 bar) – 32.4 gpm  
(122.6 L/min)  
Second auxiliary hydraulics  
Hydraulic one-way self-leveling  
Ride control

### LOADER

Auxiliary front electric control  
Hydraulic attachment coupler

### DRIVETRAIN

Creep speed mode (for EH machines only)

### FACTORY SUPPLIED ATTACHMENTS

Add-on counterweights  
Road lights  
Rotating beacon  
Four-corner LED strobe  
48 in (1.22 m) pallet forks

### SERVICE PARTS

3 in (76.2 mm) retractable seat belt  
Bolt-on heavy-duty bucket teeth

### OTHER

Language decals  
Factory-installed tires – see page 3  
Buckets – see page 3  
Bolt-on bucket cutting edges  
Bolt-on heavy-duty bucket spill guard  
Special paint  
Offsite service arrangement

**CaseCE.com**

©2026 CNH Industrial America LLC. All rights reserved. CASE is a trademark registered in the United States and many other countries, owned by or licensed to CNH Industrial N.V., its subsidiaries or affiliates. CNH Industrial Capital is a trademark in the United States and many other countries, owned by or licensed to CNH Industrial N.V., its subsidiaries or affiliates. Printed in U.S.A. Contains 10% post-consumer fiber.

IMPORTANT: CASE Construction Equipment Inc. reserves the right to change these specifications without notice and without incurring any obligation relating to such change. Availability of some models and equipment builds vary according to the country in which the equipment is used. The illustrations and text may include optional equipment and accessories and may not include all standard equipment. Your CASE dealer/distributor will be able to give you details of the products and their specifications available in your area.



CASE Construction Equipment is biodiesel-friendly. NOTE: All engines meet current EPA emissions regulations. All specifications are stated in accordance with SAE Standards or Recommended Practices, where applicable.



Always read the Operator's Manual before operating any equipment. Inspect equipment before using it, and be sure it is operating properly. Follow the product safety signs and use any safety features provided.

Form No. CCE202605TR270B  
Replaces Form No. CCE202310TR270B

**TR270B**

**4 of 4**