



CASE
CONSTRUCTION

HYDRAULIC EXCAVATORS



CX130C | CX160C

MAIN REASONS TO CHOOSE THE C-SERIES

HIGH VERSATILITY

- Standard Flow Regulation;
- Up to 10 attachments settings can be memorised;
- Optional Clamshell circuit;
- MULTI-FITS (safe, automatic and universal).

HIGH RELIABILITY

- New boom and arm design: more robust and reinforced to optimise durability and performance;
- Re-designed attachment for more durability: less maintenance cost, higher resale value.

With the CASE top manufacturing quality.

HIGH PRECISION AND CONTROLLABILITY

- Advanced Hydraulic System;
- Unique pump torque control system;
- Advanced energy management with innovative fuel saving functions;
- 3 available power modes to match customers needs.



MAXIMUM COMFORT

Extra large cab: 7% more space vs previous model.

Low noise and vibrations.

Ergonomic workstation.

Real time parameters monitoring.

Fully adjustable seat/joysticks and brand new LCD cluster.

SAFETY FIRST

- A full range of optional front guards;

- Superior visibility;

- Standard Rear view camera.

With Standard Rops cab and Fops, level II certified.

HIGH EFFICIENCY

The combination of Isuzu Tier III engine, the Advanced Hydraulic System with the 5 Energy Saving Controls and the ECO gauge function grants 10% of fuel economy.

LOW TOTAL COST OF OWNERSHIP AND REPAIR COST

- Cab filters access form

- Standard EMS (Easy Maintenance System) bushings

- Long maintenance intervals

- Low effort for serviceability

- Good service access, onboard diagnosis



C-SERIES

HYDRAULIC EXCAVATORS

POWERFUL AND FUEL EFFICIENT ENGINE

The C-Series Hydraulic Excavators are powered by Isuzu engines, designed to boost machine performances and optimize fuel economy.

The 4 cylinders Isuzu engine delivers outstanding power and torque, that reduces the transient time making the hydraulic system immediately reactive to any load.

Fuel consumption can be constantly monitored by the operator throughout the new ECO gauge function, that displays in real time the energy level utilized.



ADVANCED ENERGY MANAGEMENT

- **POWER SAVE:** the pump discharge pressure when the machine is at rest.
- **PUMP TORQUE CONTROL:** prevents drop in engine rpm when lifting heavy loads.

Less fuel consumption and effective energy usage thanks to the **5 ENERGY SAVING FUNCTIONS:**

- **BEC - Boom Economy Control:** it increases the fuel efficiency during the lowering of the boom and swing operations;
- **AEC - Automatic Economy Control:** it reduces the rpm when the joysticks are in neutral position;



- **SRC - Swing Relief Control:** the pump sends a small amount of oil at the very beginning of the slewing operations;
- **SSC - Spool Stroke Control:** automatic speed adjustment during digging and leveling;
- **AES - Auto Energy Safe:** Auto Idle and Idle Shut Down.



HIGH RELIABILITY

Improved design for durable performances

The new boom and arm are Heavy Duty, more robust and reinforced in the more stressed areas, optimise the durability and the performances at the same time: the boom is average 8% lighter than the previous series.

Increased productivity: extra lifting capacity thanks to the front attachment optimisation;

Maximum efficiency: lighter, but stronger front attachment (more lifting, less fuel consumption);

Higher resale value: re-designed attachment for more durability and less maintenance cost.



ROBUSTNESS

The C-Series Hydraulic Excavators undercarriage is made with high quality components, with thick structural plates in the areas where components required and higher level of resistance.

Heavy duty solutions

The Heavy duty undercarriage ensures safe and productive performance in all terrains.

- X-chassis design to grant a better weight distribution and a superior stability;
- Heavy duty and high quality material;
- Heavy duty travel engine protection;
- Extra heavy duty carrier roller brackets.

C-SERIES

HYDRAULIC EXCAVATORS

COMFORT AND SAFETY

- Superior wide and roomy cab with ample legroom.
- New cushioning system to lower noise and vibration levels for the operator's ultimate comfort.
- Totally adjustable workstation with fully reclinable air –suspensioned seat.
- Air conditioning system with 25% more airflow and 6% better performances.



OUTSTANDING VISIBILITY

- Wider glazed surface with single piece side window.
- New 7" LCD display grants high visibility in any light condition, this make the operator much more comfortable and safe. All machines parameters are constantly monitored to maximise performances.



COMFORT RULES

FIRST CLASS CAB AND SEAT

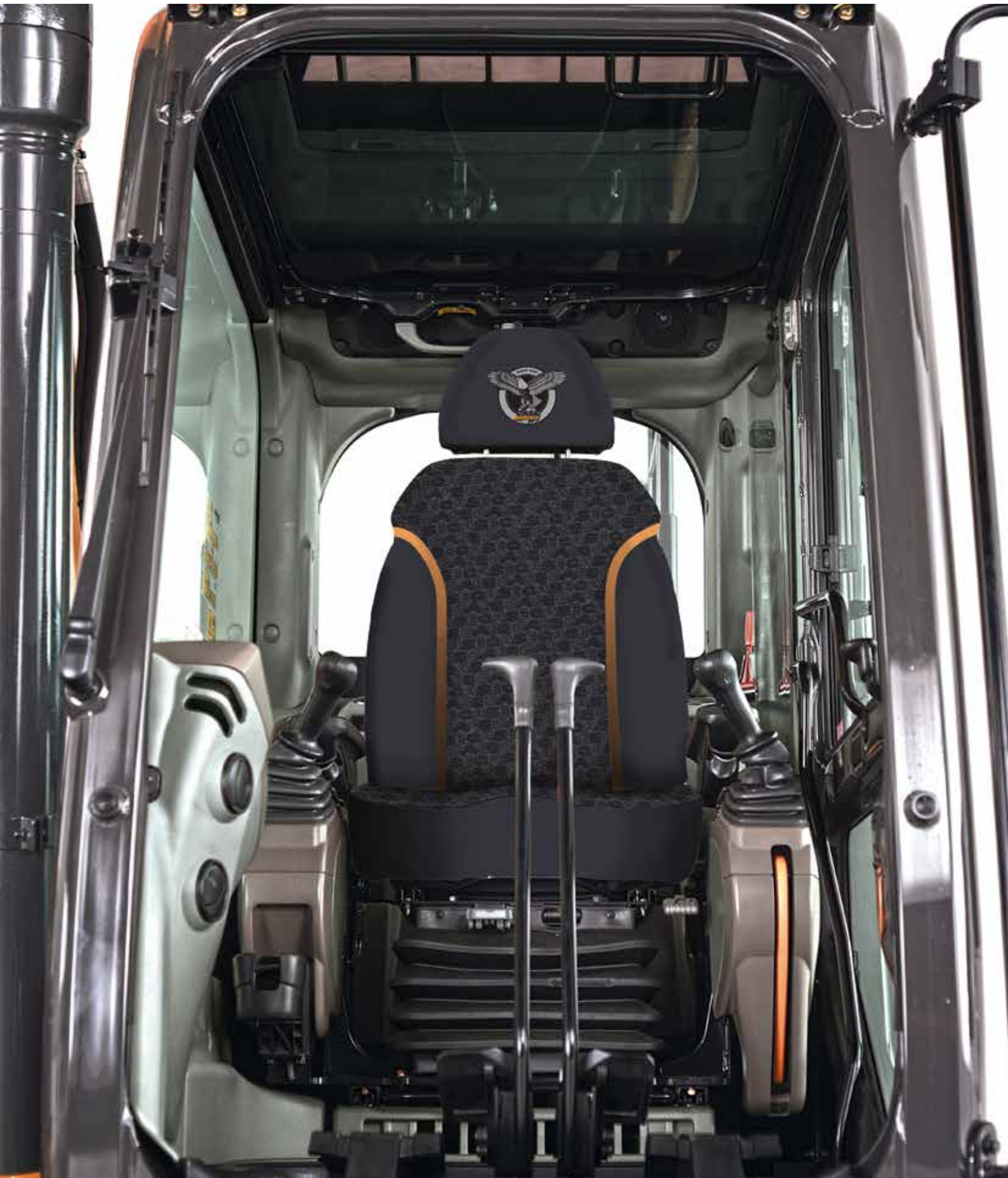



THE CASE DEALER: YOUR PROFESSIONAL PARTNER

Your success starts with world-class CASE machinery and attachments.

Your CASE dealer will help you work smarter and faster by selecting equipment that delivers performance and operator comfort.

Your dealer has the knowledge and experience necessary to help you choose the right attachments so you can...

- **Work faster and extend equipment life.**
- **Increase machine utilisation.**
- **Increase your capabilities.**

Let your CASE dealer service your machine on the jobsite.

You'll be back on the job faster.

Advantages include...

- **Responsive job site service to keep your equipment running.**
- **Increase machine uptime.**
- **Certified service staff and improved parts availability.**



PARTS

When you're looking for superior parts options to maximise the performance and lower the operating costs of your CASE machinery, turn to CNH Industrial Genuine Parts to keep you equipped for success.

CNH Industrial Genuine Parts fit better, install faster and last longer and in an industry where "high impact" and "heavy lifting" are the norm, the smallest mechanical differences can lead to big problems.

CNH Industrial Genuine Parts from CASE are manufactured from superior materials and specifically designed for CASE construction equipment to continually and reliably withstand the punishment of everyday construction. So steer clear of mechanical problems and future breakdowns, by choosing CNH Industrial Genuine Parts from CASE. They're the only parts that are field-tested and proven to keep your CASE equipment performing its best.

SERVICE. RELY ON CASE TO DELIVER FOR YOU

Your commitment to your operation is evident every day, but that doesn't minimise the enormous pressure you face to reduce operating costs and improve productivity. So when you're on the job, make sure you have top-notch service and support of CASE behind you every step of the way.

With our factory trained technicians, you can ensure that top-notch service professionals are working on your maintenance needs, so you can focus on your business and the big job challenges ahead, not on the tasks of servicing your equipment.

With your CASE Service, you get more than mere oil changes. A CASE Service ensures your CASE equipment receives a thorough service that meets all requirements of its service schedules and properly maintains it for the day-in, day-out punishment of construction work.

Don't give another thought to time-consuming maintenance tasks. Simply rest easy and make certain that your service needs are taken care of by a CASE factory trained technician.

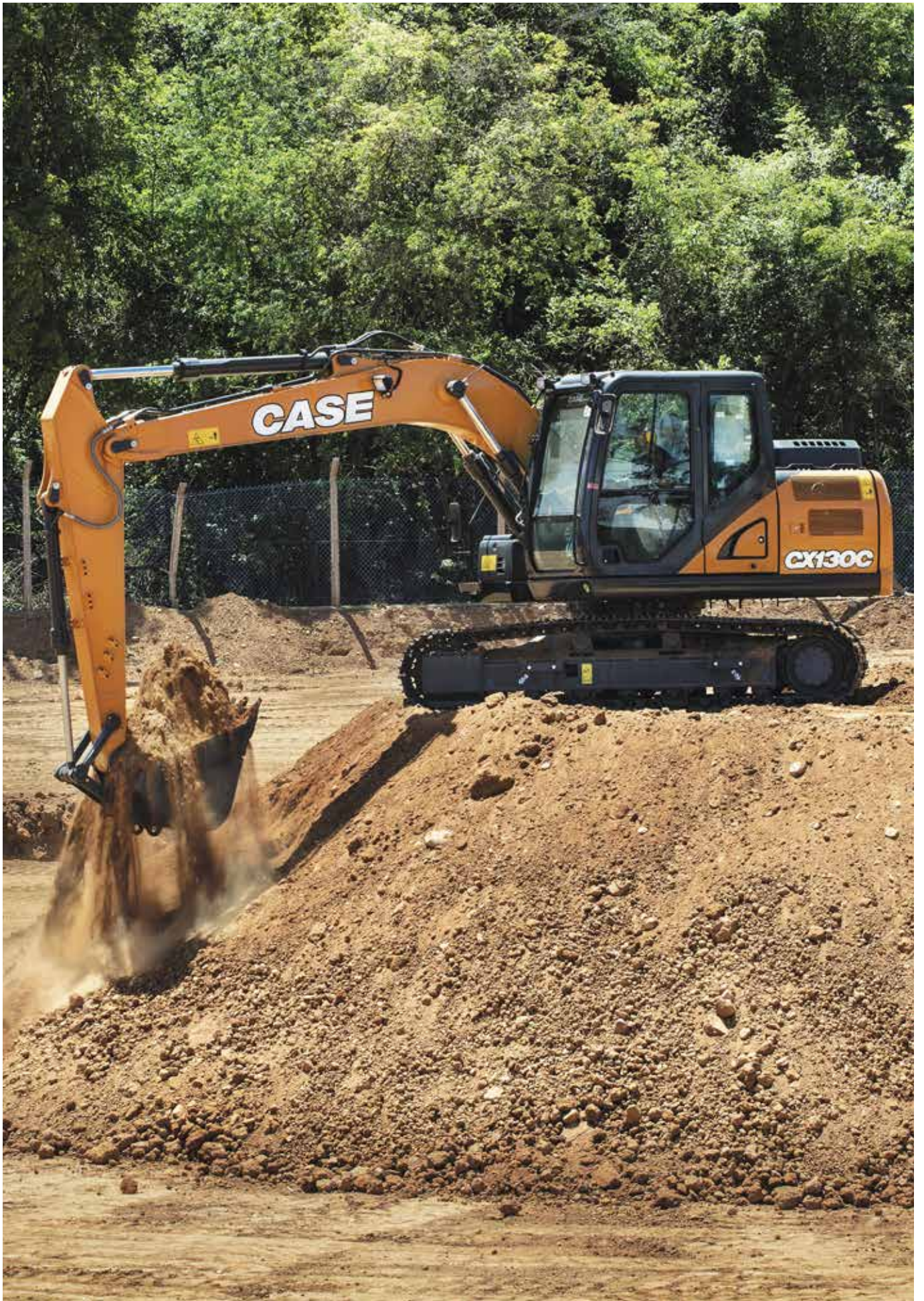

SPECIFICATIONS

CX130C

ENGINE

Model _____ ISUZU GJ-4JJ1X
 Type _____ Water-cooled, 4-cycle diesel, 4-cylinder in line,
 High pressure common rail system (electric control), Turbocharger with air
 cooled intercooler
 Emission certified _____ Tier III
 Displacement _____ 3.0 l
 Bore/Stroke _____ 95.4 x 104.9 mm
 Horsepower SAE J1349 (net) _____ 73 kW at 2000 min⁻¹
 Imperial _____ 98 hp
 Metric _____ 100 hp
 Maximum torque SAE J1349 (net) _____ 346 Nm at 1600 min⁻¹

HYDRAULIC SYSTEM

Max oil flow _____ 2 x 129 l/min @ 2000 min⁻¹
 Type _____ 2 variable displacement axial piston pumps with regulating system
 Working circuit pressure _____
 Boom/Arm/Bucket circuit _____ 34.3 MPa
 Boom/Arm/Bucket circuit (with Power Boost) _____ 36.3 MPa
 Swing circuit _____ 27.9 MPa
 Travel circuit _____ 34.3 MPa

SWING

Swing torque _____ 33,000 Nm
 Maximum swing speed _____ 14.1 min⁻¹

FILTERS

Suction filter _____ 105 µm
 Return filter _____ 6 µm
 Pilot line filter _____ 8 µm

WEIGHT AND GROUND PRESSURE

With 2.50 m Arm , 0.5 m³ bucket, 500 mm grouser shoe, operator, lubricant, coolant, full fuel tank and top guard OPG level 2

CX130C*	WEIGHT (kg)	GROUND PRESSURE (Mpa)
500 mm grouser shoe	12,800	0.041

CX130C BLADE**	WEIGHT (kg)	GROUND PRESSURE (Mpa)
500 mm grouser shoe	13,700	0.044

TRAVEL

Travel motor _____ Variable displacement axial piston motor (automatic travel
 speed shifting)
 Max travel speed _____ 5.6 km/h
 Low travel speed _____ 3.4 km/h
 Gradeability _____ 70% (35°)
 Drawbar pull _____ 116 kN

ELECTRICAL SYSTEM

Voltage _____ 24 V
 Alternator _____ 50 Amp
 Starter motor _____ 4.0 kW
 Battery _____ 2 x 12 V 72 Ah / 5 HR

UNDERCARRIAGE

Number of carriers rollers (each side) _____ 1
 Number of track rollers (each side) _____ 7
 Number of shoes (each side) _____ 43
 Type of shoe _____ Triple grouser shoe

CAPACITIES

Fuel tank _____ 260 l
 Hydraulic system _____ 157 l
 Cooling system _____ 18.2 l
 Engine crank case _____ 17

C-SERIES

HYDRAULIC EXCAVATORS

CX160C

ENGINE

Model _____ ISUZU AM-4JJ1X
 Type _____ Water-cooled, 4-cycle diesel, 4-cylinder in line,
 High pressure common rail system (electric control), Turbocharger with air
 cooled intercooler, DPD system
 Emission certified _____ Tier III
 Displacement _____ 3.0 l
 Bore/Stroke _____ 95.4 x 104.9 mm
 Horsepower SAE J1349 (net) _____ 92.2 kW at 2.200 min⁻¹
 Imperial _____ 123 hp
 Metric _____ 125 hp
 Maximum torque SAE J1349 (net) _____ 391 Nm at 1.800 min⁻¹

HYDRAULIC SYSTEM

Max oil flow _____ 2 x 142 l/min @ 2.200 min⁻¹
 Type _____ 2 variable displacement axial piston pumps with regulating system
 Working circuit pressure _____
 Boom/Arm/Bucket circuit _____ 34.3 MPa
 Boom/Arm/Bucket circuit (with Power Boost) _____ 36.3 MPa
 Swing circuit _____ 27.9 MPa
 Travel circuit _____ 34.3 MPa

SWING

Swing torque _____ 33,000 Nm
 Maximum swing speed _____ 11.5 min⁻¹

FILTERS

Suction filter _____ 105 µm
 Return filter _____ 6 µm
 Pilot line filter _____ 8 µm

TRAVEL

Travel motor _____ Variable displacement axial piston motor
 Max travel speed _____ 5.4 km/h (Automatic travel speed shifting)
 Low travel speed _____ 2.8 km/h
 Gradeability _____ 70% (35°)
 Drawbar pull _____ 161 kN

ELECTRICAL SYSTEM

Voltage _____ 24 V
 Alternator _____ 50 Amp
 Starter motor _____ 4.0 kW
 Battery _____ 2 x 12 V 72 Ah / 5 HR

UNDERCARRIAGE

Number of carriers rollers (each side) _____ 2
 Number of track rollers (each side) _____ 7
 Number of shoes (each side) _____ 44
 Type of shoe _____ Triple grouser shoe

CAPACITIES

Fuel tank _____ 300 l
 Hydraulic system _____ 165 l
 Cooling system _____ 16.2 l
 Engine crank case _____ 17 l

WEIGHT AND GROUND PRESSURE

With 2.62 m Arm , 0.62 m³ bucket, 600 mm grouser shoe, operator, lubricant, coolant, full fuel tank and top guard OPG level 2

CX160C	WEIGHT (kg)	GROUND PRESSURE (MPa)
600 mm grouser shoe	17,500	0.043

SPECIFICATIONS

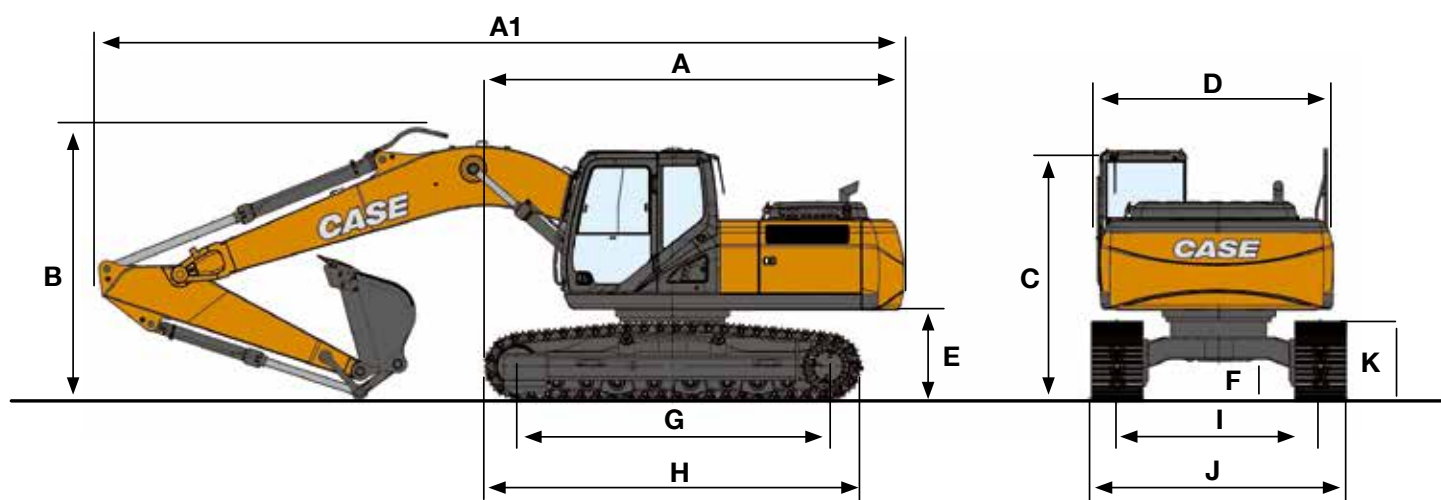

GENERAL DIMENSIONS

		CX130C Arm 2.50 m	CX130C BLADE Arm 2.50 m
A	Overall length (without attachment)	mm	3880
A1	Overall length (with attachment)	mm	7620
B	Overall height (with attachment)	mm	2920
C	Cab height	mm	2920
D	Upper structure overall width	mm	2540
	Swing (rear end) radius	mm	2130
E	Clearance height under upper structure	mm	890
F	Minimum ground clearance	mm	425
G	Wheel base (Center to center of wheels)	mm	2790
H	Crawler overall length	mm	3500
K	Crawler tracks height	mm	780
I	Track gauge	mm	1990
J	Undercarriage overall width (with 500 mm shoes)	mm	2490

		CX160C Arm 2.62 m
A	Overall length (without attachment)	mm
	Overall length (with attachment)	mm
B	Overall height (with attachment)	mm
C	Cab height	mm
D	Upper structure overall width	mm
	Swing (rear end) radius	mm
E	Clearance height under upper structure	mm
F	Minimum ground clearance	mm
G	Wheel base (Center to center of wheels)	mm
H	Crawler overall length	mm
K	Crawler tracks height	mm
I	Track gauge	mm
J	Undercarriage overall width (with 600 mm shoes)	mm

C-SERIES

HYDRAULIC EXCAVATORS

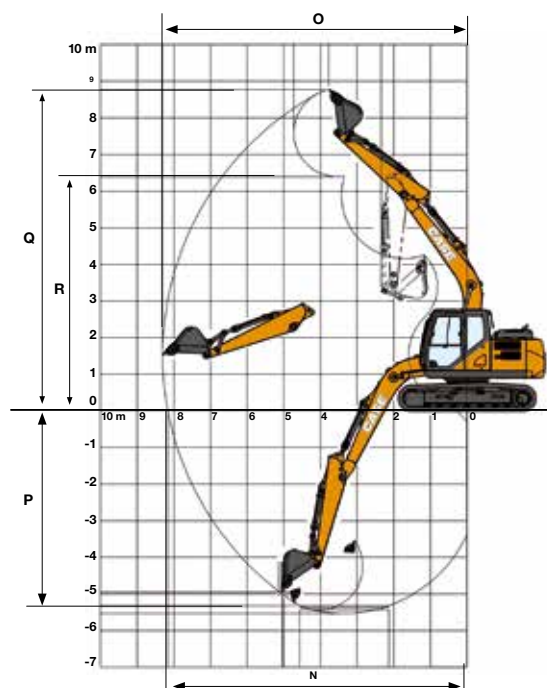

PERFORMANCE DATA

		CX130C Arm 2.50m	CX130C BLADE Arm 2.50 m
	Boom length	mm	4630
	Bucket radius	mm	1210
	Bucket wrist action	°	178
N	Maximum reach at GRP	mm	8170
O	Maximum reach	mm	8310
P	Max. digging depth	mm	5540
Q	Max. digging height	mm	8770
R	Max. dumping height	mm	6390
	Arm digging force (with Power Boost)	kN	66
	Bucket digging force (with Power Boost)	kN	95

		CX160C LC Arm 2.62 m	
	Boom length	mm	5150
	Bucket radius	mm	1350
	Bucket wrist action	°	178
N	Maximum reach at GRP	mm	8870
O	Maximum reach	mm	9040
P	Max. digging depth	mm	6060
Q	Max. digging height	mm	9240
R	Max. dumping height	mm	6610
	Arm digging force (with Power Boost)	kN	84
	Bucket digging force (with Power Boost)	kN	118

LIFTING CAPACITY

Front 360°	REACH													
	0 m		1.5 m		3.0 m		4.5 m		6.0 m		7.5 m		At max reach	

CX130C - NON BLADE. Version Standard arm. 2.50 m arm length, 0.50 m³ bucket, 500G LC shoes, max reach 8.03 m

7.5 m							1810	1810					1410*	1410*	5,22	
6.0 m									2370	2370*			1190*	1190*	6,7	
4.5 m							2860*	2860	2800	2330	1310	1310	1120*	1120*	7,53	
3.0 m						5180*	5180*	3890*	3600	3200	2220	2420	1470	1130*	1130*	7,94
1.5 m						7570*	6340	4980	3320*	3750	2080	2890	1410	1190*	1190*	8,02
0 m			2460*	2460*	7970*	5820	5690*	3080	4120*	1960	2690	1360	1330*	1260	7,82	
- 1.5 m			5020*	5020*	9070*	5770	5820*	2990	4170*	1910			1600*	1430	7,25	
- 3.0 m			7800*	7800*	8350*	5890	4580*	3040	3750*	1990			2170*	1810	6,31	
- 4.5 m					6310*	6010	3910	3190					3400*	2880*	4,76	

CX130C - WITH BLADE. Blade up. Standard arm. 2.50 m arm length, 0.50 m³ bucket, 500G shoes, max reach 8.31 m

7.5 m							1810*	1810*					1410*	1410*	5,22	
6.0 m									2370*	2110			1190*	1190*	6,7	
4.5 m							2860*	2860*	2800*	2070	1310*	1300	1120*	1120*	7,53	
3.0 m						5180*	5180*	3890*	3210	2810	1950	1880	1270	1130*	110	7,94
1.5 m						7570*	5560	4300	2920	2660	1810	1820	1210	1190*	1040	8,02
0 m			2460*	2460*	7970*	5050	4040	2690	2540	1700	1770	1160	1330*	1080	7,8	
- 1.5 m			5020*	5020*	8000*	5010	3940		2490	1650			1600*	1220	7,25	
- 3.0 m			7800*	7800*	8130	5130	3990	2650	2560	1720		1600	2170*	1560	6,31	
- 4.5 m					6310	5330	3810	2790					3400*	2520	4,76	

CX130C - WITH BLADE. Blade down. Standard arm. 2.50 m arm length, 0.50 m³ bucket, 500G shoes, max reach 8.31 m

7.5 m							1810*	1810*					1410*	1410*	5,22	
6.0 m									2370*	2370*			1190*	1190*	6,7	
4.5 m							2860*	2860*	2800*	2330	1310*	1310*	1120*	1120*	7,53	
3.0 m						5180*	5180	3890*	3600	3200*	2220	2420*	1470	1130*	1130*	7,94
1.5 m						7570*	6340	4980*	3320	3750*	2080	2890*	1410	1190*	1190*	8,02
0 m			2460*	2460*	7970*	5820	5690*	3080	4120*	1960	2690*	1360	1330*	1260	7,8	
- 1.5 m			5020*	5020*	9070*	5770	2950*	2990	4170*	1910			1600*	1430	7,25	
- 3.0 m			7800*	7800*	8350*	5890	5480*	3040	3750*	1990			2170*	1810	6,31	
- 4.5 m					6310*	6010	4010*	3280					3400*	2880	4,76	

Front 360°	REACH													
	1.5 m		3.0 m		4.5 m		6.0 m		7.5 m		9.0m		At max reach	

CX160C - Standard arm. 2.62 m arm length, 0.62 m³ bucket, 600G LC shoes, max reach 9.04 m

7.5 m							2610*	2610*					1620*	1620*	6,52	
6.0 m							3250*	3250*	2040*	2040*			1470*	1470*	7,68	
4.5 m							4230*	3250	3210*	2170			1440*	1440*	8,35	
3.0 m						8490*	8490*	6140*	4860	4840*	3050	3340	2070	1470*	1470*	8,68
1.5 m						8910*	8100	7390	4420	4630	2840	3220	1960	1550*	1490	8,7
0 m						7520*	7430	7040	4100	4440	2670	3130	1870	1730*	1540	8,44
- 1.5 m	6040*	6040*	9660*	7580	6890	3980	4350	2590	3100	1850			2050*	1710	7,88	
- 3.0 m	8600*	8600*	12880*	7720	6940*	4030	4440	2640					2690*	2110	6,96	
- 4.5 m	12550*	12550*	10390*	8030	7000	4270							4430*	3080	5,52	

* Lift capacities are taken in accordance with SAE J1097 / ISO 10567 / DIN 15019-2

Lift capacities shown in kg do not exceed 75% of the tipping load or 87% of the hydraulic lift capacity

Capacities that are marked with an asterisk (*) are hydraulic limited

If the machine is equipped with a quick coupler, subtract the weight of the quick coupler from the load shown in the table to calculate the real lift capacity



SINCE 1842

BUILDING A STRONG CASE.

Since 1842, at CASE Construction Equipment we have lived by an unwavering commitment to build practical, intuitive solutions that deliver both efficiency and productivity.

We continually strive to make it easier for our customers to implement emerging technologies and new compliance mandates.

Today, our global scale combined with our local expertise enables us to keep customers' real-world challenges at the center of our product development.

The vast CASE dealers' network is always ready to support and protect your investment and exceed your expectations, while also providing you with the ultimate ownership experience.

Our goal is to build both stronger machines—and stronger communities. At the end of the day, we do what's right for our customers and our communities so that they can count on CASE.

CASECE.com

NOTE: Standard and optional fittings can vary according to the demands and specific regulations of each country. The illustrations may include optional rather than standard fittings - consult your CASE dealer. Furthermore, CNH Industrial reserves the right to modify machine specifications without incurring any obligation relating to such changes.

Conforms to directive 2006/42/EC

