

The new STEYR EXPERT CVT with up to 140 hp

HIGH PERFORMANCE IN A **COMPACT** SHAPE



Your partner to rely on.

STEYR
TRAKTOREN

IT'S THE **TECHNOLOGY** THAT MAKES THE DIFFERENCE

Our team of expert engineers used all their knowledge to design a tractor that brings together maximum control, superior drivability and high performance in a compact package.



The outcome: the EXPERT CVT, the tractor that knows no compromise in terms of comfort, efficiency and quality

Whether on grassland, arable fields, roads or farmyards, the new STEYR EXPERT CVT lives up to its name. The STEYR EXPERT CVT is ideal for anyone who needs a compact tractor but does not want to give up on performance and maximum comfort. For the first time it delivers technologies such as the STEYR S-Control™ CVT transmission and its S-TRONIC control technology in the 100 hp segment. Only the best is good enough for experts.

» **The tool for true experts.**



04 – 05

What's new

24 – 25

S front loader

06 – 07

EXPERT CVT at a glance

26 – 27

4WD and safety

08 – 09

Packages

28 – 29

S-Tech Precision Farming

10 – 15

Cab

30 – 31

S-Fleet

16 – 17

Engine

32 – 33

STEYR service

18 – 19

**S-Control CVT
transmission**

34 – 35

Specifications

20 – 23

**Front- and rear
linkage area**

BENEFIT FROM THE FINEST **TECHNOLOGY**





New premium comfort

Available in both standard and panorama roof versions, for a perfect visibility on the front loader, the 4-pillar cab offers the very best in terms of comfort: leather steering wheel, a choice of seats, the armrest that fits your needs and much more.



New S-TRONIC custom settings for EXPERT CVT

Individually set-up on the new S-Tech 700 Plus monitor your S-Control™ CVT transmission settings according to your operation.



New logical layout

The ultimate range of remote controls – 2 armrests – Multicontroller II for “mechanical” or a mix of “mechanical+electrical” rear remotes or the Multicontroller armrest for 3 or 4 electronic rear remotes.



New – the perfect match

Whether you're working around the farm yard or in the fields, the new STEYR S front loader series is the perfect match to your tractor and the challenges you face in your day-to-day work.



WHAT MAKES AN **EXPERT**



Low noise level of 69 dB(A) to take the stress out of working and when using a mobile phone hands-free mode.



Up to 18 LED-worklights for perfect 360° illumination.



Ergonomic operation using the Multicontroller or Multicontroller II armrest.



Dual-Motion driver seat, cab suspension and front axle suspension for more comfort.



Powerful, economical and ecological: the 4-cylinder engines from 110 up to 140 hp fulfill the Stage V emission standard.



S-TRONIC has been further advanced and offers customizable control features.

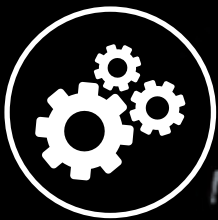

S-Control™ CVT: continuously variable transmission with ultimate mechanical efficiency rating.



40 kph achieved at a fuel-efficient 1,600 rpm.



Active hold control for stopping on a steep slope without a brake.



Headland management Easy-Tronic II for the automation of work operations, dependent on time and distance covered.



Three rear PTO speeds with Power mode or with the fuel-efficient ECO mode. Optional stationary PTO.



Maximum rear lift capacity of up to 5,600 and 2,300 kg at the front.



Perfect loader work set-up with the STEYR S series front loaders.



Electronic Front Hitch control (EFH) with implement strain relief more safe and more efficient mowing on steep slopes.



Combinations of tyres and wheels to suit every type of application.



The EXPERT CVT supports ISOBUS II and ISOBUS III.



S-Tech Precision Farming: fully automatic turning with S-GUIDE and S-TURN II.



S-Fleet lets you remotely monitor and manage your farm, fleet and data.

STEYR

4140 EXPERT CVT



EXPERT CVT ALL INCLUSIVE

Well equipped

Your EXPERT CVT is available in four equipment configurations for convenience. Custom, for the a la carte approach, and Element, Evolution and Excellence that configure the best EXPERT CVT options conveniently. You can quickly select the features that matter to you. The equipment packages can be changed by STEYR without prior notification. Please contact your local dealer for the latest configuration.

Element

The package for versatile use

Mechanical remotes, 110 l/min hydraulic pump and 3 speed PTO are standard with Element to let you perform a wide variety of agricultural applications with maximum ease and satisfaction.

» FACTS

- ▶ Front axle suspension optional
- ▶ Front linkage options
- ▶ Mechanical remotes and 110 l/min hydraulic pump, 3 speed PTO
- ▶ Multicontroller armrest options
- ▶ Low roof with panorama window or high roof with air conditioning, passenger seat

Evolution

Evolution in comfort and performance for the customers

Front axle suspension is standard with Evolution. As are the low roof cab with panorama window or high roof suspended cab with air conditioning. Whatever you choose, comfort and performance are guaranteed.



» FACTS

- ▶ Front axle suspension
- ▶ Front linkage with front hitch management options
- ▶ ElectroHydraulic remotes and 110 l/min hydraulic pump, 3 speed PTO
- ▶ Low roof with panorama window or high roof with air conditioning, passenger seat & suspension
- ▶ Multicontroller armrest options, headland management options on S-Tech screen & autoguidance options
- ▶ ISOBUS class II optional

Excellence

High-end performance and superior operator comfort features

Everything you ever dreamed on a tractor, ready for you in package dedicated to excellence. Everything becomes easier, quicker and much more comfortable on the field, on the road and in the yard. And productivity grows.



» FACTS

- ▶ S-Control CVT continuously variable transmission with ultimate mechanical efficiency rating
- ▶ Front axle suspension
- ▶ Front linkage with front hitch management options
- ▶ ElectroHydraulic remotes and 110 l/min hydraulic pump, 3 speed PTO
- ▶ Low roof with panorama window or high roof with air conditioning, passenger seat & suspension
- ▶ Multicontroller armrest options, advanced headland management on S-Tech screen & autoguidance ready
- ▶ ISOBUS class II or III



IT MAKES WORK **ENJOYABLE**

EXPERT CVT comfort

The EXPERT CVT leaves a great impression both inside and out. The spacious cab offers a work environment where anyone simply feels comfortable. That's not only because there are three seat variants to choose from, but also courtesy of the choice of armrests. The panorama roof window provides unobstructed visibility of the front loader.



Really good looking. At day and night

Perfect and unrestricted all round visibility - thanks to the 4-pillar panorama cab with its large windows, high-visibility roof window and one-piece front windscreen. The LED work light package assures superlative visibility even after night has fallen. Standard equipment comprises 6 LED work lights at the front of the roof, another 6 at the back of the roof, and 2 more LED work lights on the bonnet. An optional 4 LED work lights, one fitted low on each cab pillar, front and rear, are also available. The light intensity of 2,000 lumens per LED headlight turn night into day and ensure accurate, efficient work.



» FACTS

- ▶ Cab suspension
- ▶ Low noise level of just 69 dB(A)
- ▶ Automatic air-conditioning system
- ▶ Three driver seat options
- ▶ Up to 18 powerful LED worklights

A low mounted wiper increases the swept coverage area by 60% compared to previous models.

OPERATE YOUR **EXPERT**. EXACTLY HOW YOU WANT

Thanks to the ergonomic Multicontroller armrest, you always have everything under control in the STEYR EXPERT CVT. You can choose between two options: the tried-and-tested Multicontroller armrest, which can already be found in larger tractors, and the exclusively STEYR developed Multicontroller II armrest. But both have the same goal. To make your work as easy as possible.

Everything under control with the Multicontroller

In the comfortable EXPERT CVT cockpit, you are in control. 12 freely programmable short cut menus allow quick access to key EXPERT CVT functions on the S-Tech 700 Plus monitor. Simple to access and even more convenient to set-up. At the centre of the STEYR Multicontroller armrest is the Intuitive Control Panel, a smart layout of key features that allows all drivers to get the best from the machine.

» FACTS MULTICONTROLLER

- ▶ Ergonomic operation with Multicontroller
- ▶ Joystick and levers for operating auxiliary control units at front and rear
- ▶ PTO switch
- ▶ Eco-Drive™ control lever
- ▶ You can choose to have either one or 2 screens to monitor your work in the field
- ▶ S-Tech 700 Plus monitor
- ▶ ISOBUS Aux-N
- ▶ Rotary control for hydraulic settings and possibility to manage up to 4 electrohydraulics remotes



Multicontroller armrest

In order to monitor your work in the field the way you like it more, you can choose to have one or two screens in the cab: one on the armrest and the other on the monitor bracket.

Multicontroller II. Exclusively for you. Exclusively from STEYR

Ergonomic operation with Multicontroller Joystick and levers for operating auxiliary controls at front and rear. Possibility to control up to 2 mechanical and 2 electro-hydraulic remotes. PTO switch. ICP (Intuitive Control Panel). Eco-Drive™ control lever. Rotary control for hydraulic settings. ISOBUS Aux-N.



Freely configurable

Thanks to the Multicontroller-II armrest and S-Tech 700 Plus monitor you have the possibility to configure three buttons on the Multicontroller as well as the buttons and axes of the joystick.



Front loader joystick

With three configurable buttons, Powershuttle and speed controller.

» FACTS MULTICONTROLLER II

- ▶ Configuration button of the screen on the joystick
- ▶ Electronic Front Hitch management available
- ▶ New monitor S-Tech 700 Plus Connect plus placed at the top of the cabin
- ▶ Branded armrest and exclusive features included





IT SIMPLY **OUTSHINES** EVERYTHING

The choice is yours

The STEYR EXPERT CVT is available with two different cab variants. They all have, however, the spacious 4-pillar structure, an ergonomic design and a LED work light package with up to 18 LED work lights, each with 2,000 lumens that turn night into day.



Standard roof



Panorama roof

» FACTS

- ▶ 4-pillar cab
- ▶ Two roof variants
- ▶ Panorama window
- ▶ Up to 18 LED work lights



A REAL, **POWER** HOUSE

Turbocharged four cylinder power

Tried and tested FPT Industrial 4-cylinder NEF 4.5 litre engines work away under the bonnet of the STEYR EXPERT CVT, with an maximum output of 110 to 140 hp. Each model easily meets the requirements of the Stage V EU emissions standard thanks to the patented aftertreatment system, which is also fitted under the bonnet.



ECO DRIVE

The dual hand throttle allows the individual adjustment of the minimum and maximum engine speed, adjusting the vehicle characteristics according to the required task and minimizing fuel consumption.

1 POWER MODE – Pulling and transport

Full potential of the engine is available.

2 ECO MODE – Pulling and transport economy

With the right hand throttle lever you can limit the maximum engine speed to save fuel.

3 PTO MODE

Set the desired engine (PTO) speed with the left hand throttle lever. The right hand throttle lever determines the engine speed down to which the engine can be drooped, before the transmission reduces the ground speed.

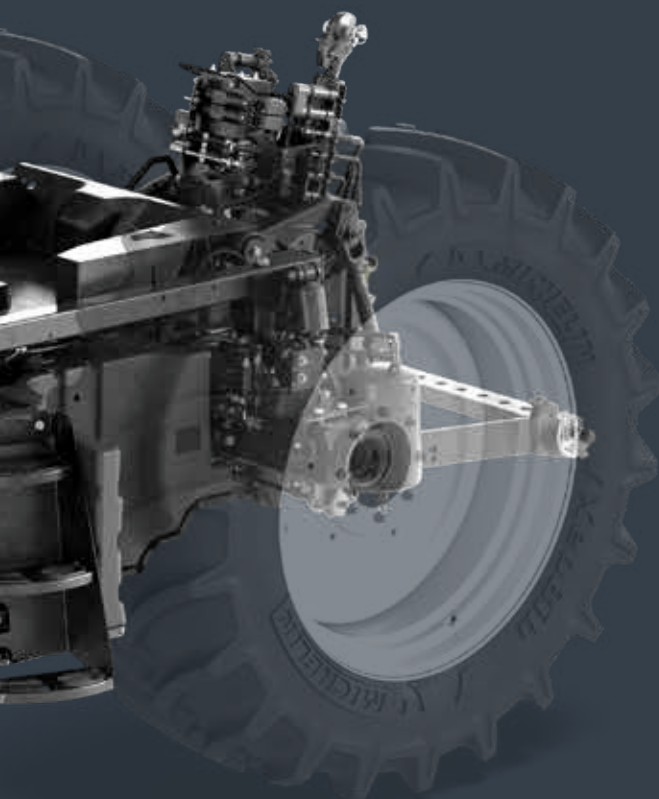

» FACTS

- ▶ 4-cylinder engines with turbocharger and intercooler
- ▶ 4.5 litre cubic capacity
- ▶ Rated power output: 100 – 130 hp. Max. power output: 110 – 140 hp
- ▶ High maximum torque with up to 630 Nm
- ▶ HI-eSCR2 technology from FPT fullfil Stage V
- ▶ S-TRONIC engine and transmission management
- ▶ Engine is fully compatible with hydro-treated vegetable oil, or HVO (bio-synthetic diesel)
- ▶ Up to 48% torque increase
- ▶ Long engine service intervals (750 hours)
- ▶ Reversible fan
- ▶ Engine exhaust brake
- ▶ 180-litre fuel tank to help maximise the working day

COMFORT MEETS EFFICIENCY

S-Control™ CVT transmission

Maximum torque with minimum fuel consumption, electronic control that permits even faster changes in direction and active stationary control to stop safely on a steep gradient: the continuously variable S-Control™ CVT transmission is a leader in comfort and efficiency.

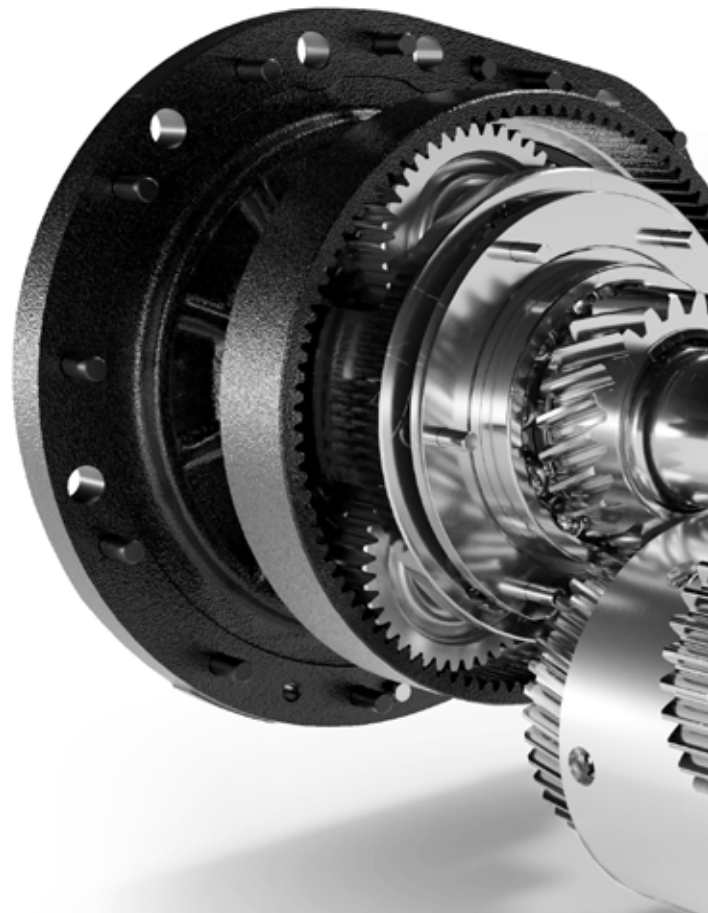

» FACTS

- ▶ Steplless from 0 to 40 kph
- ▶ 40 kph at reduced engine revs
- ▶ Two points of 100% mechanical efficiency
- ▶ Active hold control
- ▶ DKT – Double clutch technology
- ▶ Kick-down functionality
- ▶ S-TRONIC engine and transmission management
- ▶ CVT custom dynamics
 - Acceleration / deceleration
 - Shuttling speed
 - Drive pedal behavior
 - Engine torque response



S-TRONIC custom settings

Individually set-up your S-Control™ CVT transmission settings according to your operation.

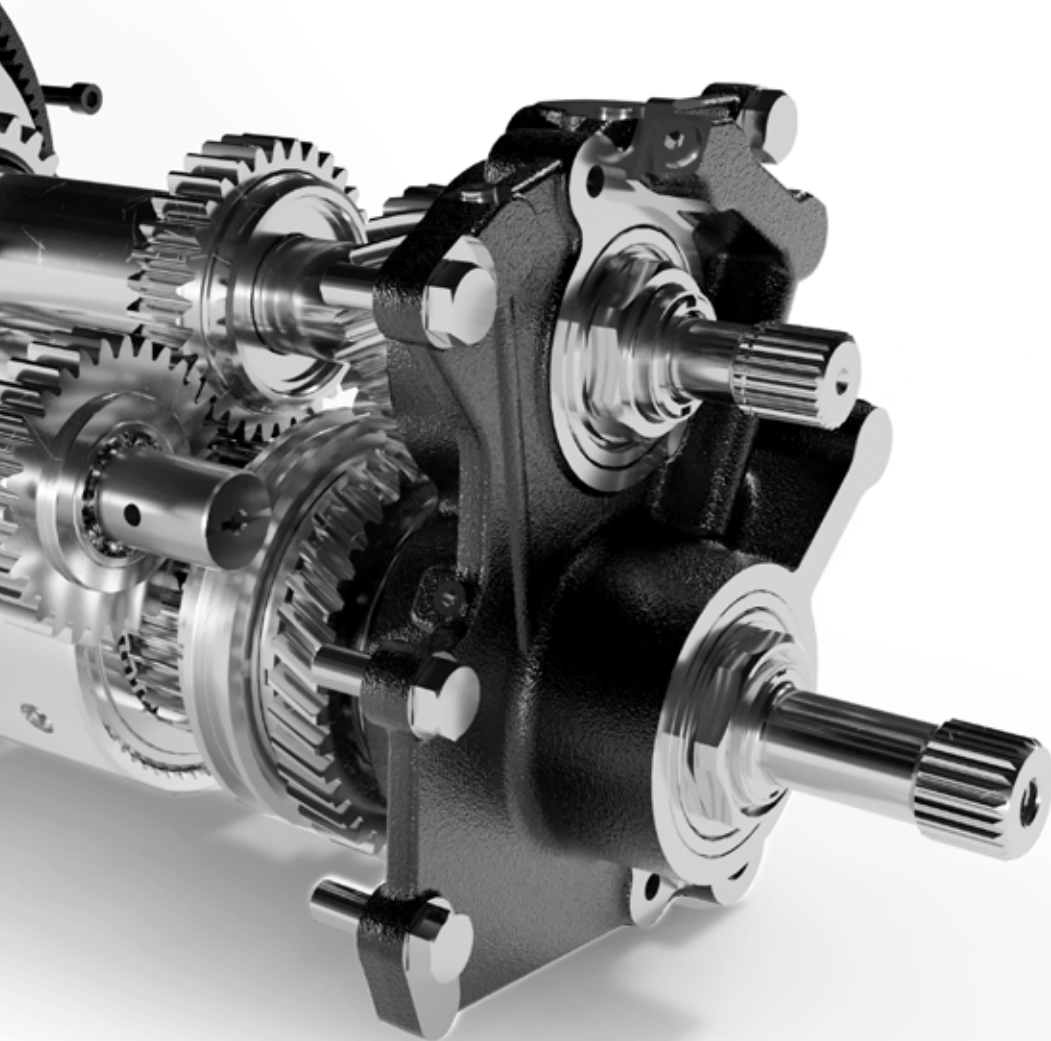

A MATCH FOR ANY TASK. ONE STEP **AHEAD**

Fully integrated

An expert leads the way: the multi-functional front-mounted hitch is integrated into the front axle support frame and offers, in addition to the powerful front hydraulics with a lifting capacity of up to 2,300 kg, also a PTO that can reach 1,000 rpm at an engine speed of just 1,895 rpm. Attaching an implement is made safer and easier via easy-to-access remote hitch and PTO switches, and once back in the seat the operator will find an excellent view to the implement. The new wet clutch for front PTO significantly improves performance and reliability while reducing noise emission.



Convenient hitching

The STEYR EXPERT CVT remote operating switches for hitch operation to aid safe hitching.

FRONT PTO

- ▶ PTO perfectly integrated
- ▶ 1,000 rpm front PTO
- ▶ New wet clutch
- ▶ Front PTO-management
- ▶ Progressive soft start
- ▶ ElectroHydraulic engagement under load

FRONT LINKAGE

- ▶ 2,300 kg maximum lift capacity
- ▶ Seven-pin lighting and 40-A plug sockets fitted standard
- ▶ Electronic front implement damping available as an option



Implement and land protection

The optional front implement damping system protects implements as well as the land and noticeably improves the traction of the front axle. It is available in combination with the Multicontroller-II armrest.



HEAVY TASKS? MAKE THEM **LIGHT WORK**

Always in good hands

Ready to meet any challenge: The new STEYR EXPERT CVT is equipped as standard with a powerful CCLS hydraulic system that delivers a flow rate of 110 l/min. The robust rear hitch (Cat. II or III N) lifts up to 5,600 kg, making it possible to easily use heavy tillage equipment. Two mechanical remote valves are provided as standard, while the tractor's capabilities can be extended with mechanical, mixed or full electro-hydraulic remotes. Available configurations are: 3 or 4 mechanical, 2 mechanical and 2 electro-hydraulic, 3 or 4 electro-hydraulic. The rear PTO is available with two or three speeds.

REAR HITCH

- ▶ Up to 5,600 kg lifting capacity
- ▶ Improved top link fixing for better stability and position indicator
- ▶ CCLS hydraulic system with up to 110 l/min pump capacity
- ▶ Electronic Hitch Regulation (EHR)
- ▶ Ride Control – dynamic vibration damping
- ▶ Up to seven electrohydraulic remote valves (four on the rear, three centrally mounted)
- ▶ Power-Beyond connection
- ▶ Easy setup through S-Tech 700 Plus monitor



Easy setup

Shortcut keys bring you directly to the settings menu to configure your Multicontroller handle.

Easy to reach

External controls on both fenders for easy implement connection.



REAR PTO

- ▶ ElectroHydraulic engagement under load
- ▶ PTO-Management
- ▶ Progressive soft start
- ▶ External controls on both rear fenders
- ▶ PTO with three speeds: 540/540E/1,000
- ▶ Ground speed PTO optional



THE **PERFECT MATCH** IS JUST IN FRONT OF YOU

The new STEYR S series front loaders

Whether you're working around the farm yard or in the fields, the new STEYR S front loader series is the perfect match to your tractor and the challenges you face in your day-to-day work. Offered with premium specifications, you have the choice among 20 models across two ranges, compatible with an output of 58 to 240 hp and can be customized to cover the multiple application required for powerful handling tasks.

The front loader mounting brackets and boom are perfectly designed to match your STEYR tractors, allowing easy access to all maintenance points without restricting your tractor's manoeuvrability.



Scan the QR-Code and get more information about STEYR S Series front loaders.

U Range

Versatility for everyday handling tasks

The versatile and durable U front loader range, with mechanical self-levelling, is ideal for everyday handling tasks. Easy-to-operate and robust, they are offered with the FITLOCK 2+ System® for quick hitching/unhitching and the MACH System® to safely connect all hydraulic and electrical lines. In addition, they feature an easy access to the 3rd function for implements requiring a hydraulic supply.



» FACTS

- ▶ 4 models
- ▶ Lifting capacity: 2,151 to 2,848 kg
- ▶ Lifting height: 3.85 to 3.95 m
- ▶ With or without mechanical self-levelling
- ▶ Optional 4th function

» FEATURES

- ▶ FITLOCK 2+ System®
- ▶ MACH System®
- ▶ SHOCK Eliminator

T Range

Performances with no compromises

If you need extra performance, the T range is tailor made for the highest demands with enhanced comfort. Designed to perform heavy-duty operations, the T range is equipped with the PCH hydraulic self-levelling linkage, which allows a large crowd angle, up to 52° at ground level, and increases the lifting power by 35% without needing any additional energy input. Which results into more amount of material on the bucket and less transport.



» FACTS

- ▶ 4 models
- ▶ Lifting capacity: 1,947 to 2,646 kg
- ▶ Lifting height: 3.85 to 3.95 m
- ▶ Hydraulic self-levelling PCM standard
- ▶ Hose and wiring harness are completely integrated in the boom and the crossbar

» FEATURES

- ▶ FITLOCK 2+ System®
- ▶ MACH System®
- ▶ SHOCK Eliminator
- ▶ FAST-LOCK System®
- ▶ AUTO-UNLOAD System®
- ▶ MACH 2®

SHOWCASING COMFORT

Excellent drive characteristics

What experts really want: power and comfort. The STEYR EXPERT CVT combines these features like almost no other tractor in this power segment and always efficiently delivers up to 140 hp to the ground – whether working on soil, dirt tracks or asphalt.



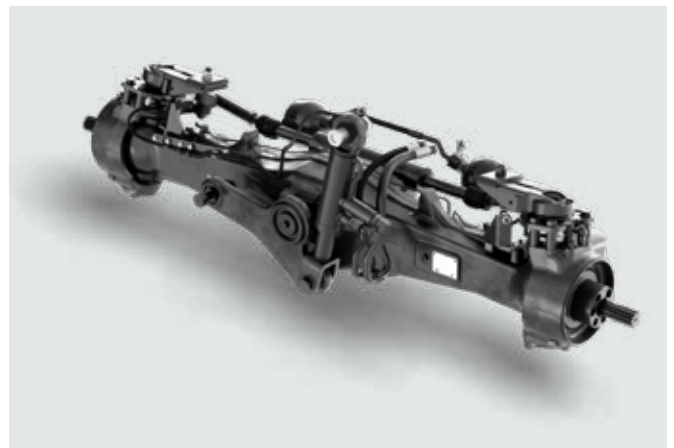

Suspended front axle. Rock & roll no more

Sharing the same renowned suspension concept as PROFI tractors, the EXPERT CVT suspended front axle keeps the tractor chassis stabled and levelled. At the same time, it takes care of absorbing all the shocks that could be experienced during transport operations or when travelling with a heavy mounted implement. A manually operated switch allows the operator to raise/lower the tractor's front-end for added safety and comfort.



Automatic self-levelling for a smoother ride

Load-sensing automatic self-levelling and controlled damping, courtesy of an advanced accumulator and regenerative valve system, pave the way for a smoother ride. You can adjust suspension settings, choosing soft, normal or hard, by simply pressing a button on the control panel.

ADVANCED, **EASY TO USE** TECHNOLOGY AT YOUR FINGERTIPS

Up to 1.5 cm Track Precision

The automatic DGPS-based s-guide integrated steering system assures parallel tramline guidance for work in straight lanes, on curves and in the headlands. The system guarantees 100% network coverage and uses the revolutionary X-FILL technology to bridge signal losses lasting up to 20 minutes. With a precision of up to as little as 1.5 cm through an owned comprehensive S-Tech RTK+ network, there is no risk of overlapping even with tough ground or weather conditions.



S-Tech 700 Plus & ISOBUS

The S-Tech 700 Plus touchscreen monitor offers an effective control and precision guidance system for arable farming. ISOBUS II-compatible attachments can easily be connected and controlled without additional wiring simply using the monitor.



Lower your operation's input costs with section control

The technology will automatically switch sections on/off in areas that have already been covered to avoid overlap on passes in field, at headland turns and irregular fields shapes. This lowers your operation's input costs by eliminating double applications of seed and fertiliser.

» FACTS

- ▶ Range of signal accuracies available (EGNOS, Range Point RTX and S-Tech RTK+ signals)
- ▶ Optional high accuracy RTK+ signal with accuracy levels close to 1.5 cm
- ▶ X-FILL bridges RTK+ signal gaps of up to 20 minutes
- ▶ S-Tech 700 Plus monitor with touchscreen
- ▶ ISOBUS II and ISOBUS III compatible
- ▶ S-GUIDE is an integrated automated steering system
- ▶ S-TURN II automates turns at the end of a row

TECHNOLOGY TO KEEP YOU **AHEAD** OF YOUR WORK

S-Fleet telematic solutions

S-Fleet lets you remotely monitor and manage your farm, fleet and data, allowing you to optimise your performance, productivity and flexibility. Efficiently visualise your equipment with little to no idle time. With all the information at your fingertips, you can successfully manage your operations anytime, anywhere!



Keep an eye on your farm
Crop and weather monitoring
Operation control in real time



Keep an eye on your fleet
Machine tracking and monitoring
On-time notifications

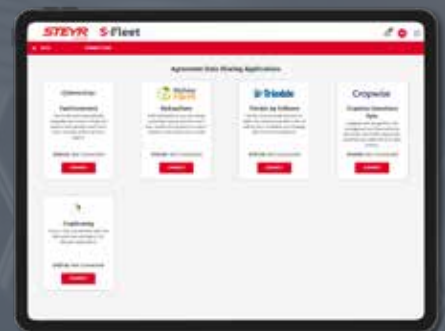

Keep an eye on your data
Data sharing
Connect with 3rd party partners

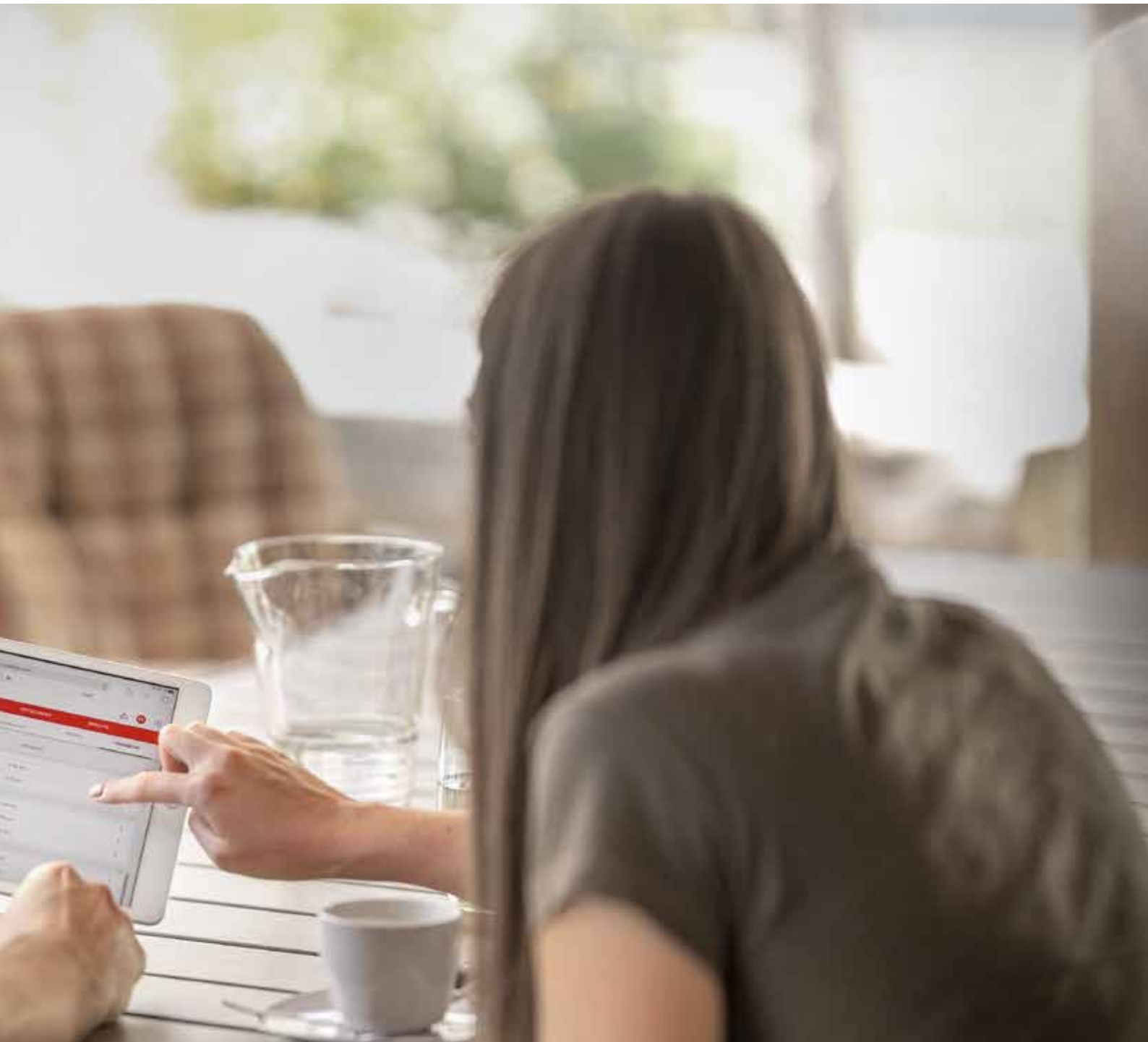

Keep an eye on everything

Download the S-Fleet App and keep an eye on your operation anytime, anywhere!



One place to manage all your tractors as well as your equipment and devices.



» FACTS

- ▶ S-Fleet telematic solutions for maximum productivity
- ▶ User-friendly interface
- ▶ Time-saving management
- ▶ Data visualisation enhancing decision making
- ▶ Efficiently track your equipment's location and view machine parameters in real time
- ▶ mySTEYR is your destination for STEYR product support
- ▶ Solutions for mixed fleets – DataConnect

ALL IN ONE

Premium tractors deserve premium cares. STEYR products and services are available and operating 24/7. Now and ever.

STEYR PARTS

QUALITY DOWN TO THE LAST DETAIL. STEYR GENUINE PARTS

Our certified Genuine Parts are designed for your STEYR tractor according to the exact specifications of our engineers and submitted to the most rigorous quality tests for conformity, robustness, safety and endurance. They last longer and perform better. Overtime. We work closely with our STEYR Dealers to ensure the availability and prompt deliveries, saving you lengthy downtimes.

THE VALUE ALTERNATIVE. STEYR REMAN PARTS

STEYR REMAN parts are the result of a thorough industrial process of disassembly, cleaning, treatment and re-assembly, which ultimately guarantees 100% reliability. That's why they also come with a 12-month warranty, saving you up to 30% compared to new parts. And respect the environment.

UPGRADE YOUR TRACTOR. STEYR ACCESSORIES

With our accessories and kits, you can improve and customize your STEYR tractor to your own requirements – add a fuel preheater, additional headlights, rear cameras, control units and much more for an exclusive and efficient result.



STEYR SERVICES

TECHNICAL SUPPORT

STEYR Service experts, whether out in the field, at your dealer or on dedicated customer helplines, are ready to ensure quick and efficient solutions through their deep knowledge of STEYR equipment.

S-Tech Protect

S-Tech Protect is the all-inclusive package that groups together the very best of STEYR workshop, field and remote services to deliver maximum equipment uptime. With S-Tech Protect you can upgrade your 5-year extended warranty to the next level of connection, operational safety and cost control, and enjoy S-Tech Connect real-time services with remote diagnostic tools, 24/7 Premium Service, professional annual inspection and even free training.

Premium Service

At STEYR, we have Premium Service, our customer support active 24 hours a day/7 days a week, no matter what you need. Call us on 080078397000 – the call is free. Working closely with STEYR dealer network, we offer a high level of customer care and provide fast feedback for any enquiry, from general information to Service assistance to reduce any downtime you might experience.

STEYR Protect

STEYR Protect is the Manufacturer Extended Warranty program developed to protect your investment from unpredictable costs or machine downtimes. STEYR Protect is an extension of the Manufacturer Standard Warranty (first year) designed to support you with:

- Manufacturer warranty
- Best possible coverage
- Optimization of Total Cost of Ownership
- Enhanced profitability
- Higher residual value
- Transferable within the market

SPECIFICATIONS

MODEL		4110 EXPERT CVT		4120 EXPERT CVT		4130 EXPERT CVT		4140 EXPERT CVT	
TRANSMISSION									
S-Control™ CVT Continuously variable transmission Driving speed* 0-40 kph			•		•		•		•
ENGINE									
Common rail diesel engine with HI-eSCR2 technology, 16 valves, turbocharger and intercooler, fulfills emission standards Stage V Number of cylinders / Capacity [cm³]		4 / 4,485		4 / 4,485		4 / 4,485		4 / 4,485	
Max. engine power ECE R120 ¹⁾ [kW/hp]	Rated engine power ECE R120 ¹⁾ [kW/hp]	81 / 110	74 / 100	88 / 120	81 / 110	96 / 130	88 / 120	103 / 140	96 / 130
Engine speed at max. engine power [rpm]	Rated engine speed [rpm]	1,700 - 1,900	2,200	1,700 - 1,900	2,200	1,700 - 1,900	2,200	1,700 - 1,900	2,200
Max. torque [Nm @ 1,400 rpm]		520		551		610		630	
Torque increase OECD [%]		48		44		46		41	
Fuel tank Diesel / AdBlue® [l]		180 / 19		180 / 19		180 / 19		180 / 19	
PTO Shiftable with progressive electro-hydraulic engagement with soft start									
PTO speed [rpm] 540 / 540E / 1,000			•		•		•		•
Engine speeds [rpm] 1,969 / 1,546 / 1,893			•		•		•		•
Stationary PTO			•		•		•		•
Front PTO* 1,000 @ 1,895 engine speed [rpm]			•		•		•		•
HYDRAULICS									
EHR hitch control with dynamic vibration damping Ride Control			•		•		•		•
Max. pump flow rate with pressure/volume control, load Sensing 110 l/min			•		•		•		•
Max. operating pressure [bar]		210		210		210		210	
Max. lifting capacity through range [kg]		5,600		5,600		5,600		5,600	
Remote valves	rear, up to 4 can be configured 2 mechanical / additional 2 mechanical or 2 electrical		• / •		• / •		• / •		• / •
	midmounted, up to 3 electrical		•		•		•		•
Integrated front hitch* max. lifting capacity [kg]		2,300		2,300		2,300		2,300	

MODEL		4110 EXPERT CVT	4120 EXPERT CVT	4130 EXPERT CVT	4140 EXPERT CVT
ALL-WHEEL DRIVE					
Engagement electro-hydraulic with traction management		●	●	●	●
FRONT AXLE STEERING					
Suspended front axle		●	●	●	●
Steering system Hydraulic, load-sensing system		●	●	●	●
Steering wheel Height- and tilt-adjustable		●	●	●	●
Steering angle Track width ²⁾ 1,830 mm [°]		55	55	55	55
Min. turning radius Track width ²⁾ 1,830 mm [m]		4.5	4.5	4.5	4.5
BRAKES					
Wet dual brake discs, hydraulically actuated		●	●	●	●
All-wheel brake with Opti-Stop		●	●	●	●
Two-line compressed air braking system		●	●	●	●
TYRES					
Maximum tyres³⁾	Front	480/65R28	480/65R28	480/65R28	480/65R28
	Rear	600/65R38	600/65R38	600/65R38	600/65R38
WEIGHT					
Approximate shipping weight* [kg]		5,500	5,500	5,500	5,500
Permissible total weight [kg]		8,800	8,800	8,800	8,800
DIMENSIONS²⁾					
Total length [mm]		4,784			
Min. – max. width [mm]		1890 – 2164			
Total height Standard roof / Low roof / Panorama roof [mm]		2,885 / 2,730 / 2,755			
Wheelbase [mm]		2,490			
Min. – max. track width front [mm]		1,446 – 2,154			
Min. – max. track width rear [mm]		1,530 – 2,138			

● Standard ● Optional – Not available

* Depending on country-specific legislative requirements and specifications

¹⁾ ECE R120 complies with ISO 14396 and 97/68EC

²⁾ With standard tyres

³⁾ Other tyres available as special equipment on request (i.e. as cost options)

You drive better when you are safe. Before using this vehicle, please read the Operating Manual and become familiar with the use of each of the controls. Note the contents of the instruction panels and use the safety equipment for your own personal safety. This brochure is intended for use internationally. The availability of a few models and of standard and special equipment items may vary from one country to another.



STEYR reserves the right at any time and without prior announcement to make changes to the design and technical version without this in any way obliging STEYR to transfer these to units already sold.

Details, descriptions and pictorial material reflect the current status at the date of publication, but can be amended without prior announcement and at any time. Pictorial materials may show certain national versions, items of special equipment as well as non-complete standard versions.

TP01 / SM / 09.23 / Printed in Austria – Cod. n. 22S0035COMINB
www.steyr-traktoren.com

steyr-traktoren.com



STEYR
TRAKTOREN