

3 - CONTROLS AND INSTRUMENTS

Access to operator's platform

Door and steps

▲ CAUTION

Pinch hazard!
 Be careful not to get your hand, clothes, etc. caught in the door when closing it.
 Failure to comply could result in minor or moderate injury.

C0046A

Cab door

To open the door, use the handle (1) from the outside and use the handle (2) from the inside.

NOTICE: Before opening the door from the inside, make sure to place the gate lock lever in central position. The left-hand control lever might be touched inadvertently when opening the door, and the machine may thus move suddenly and inadvertently causing severe incidents.

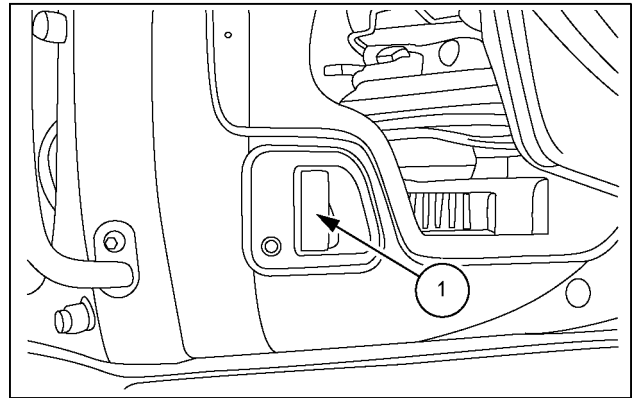

SMIL14CEX1649AB 1

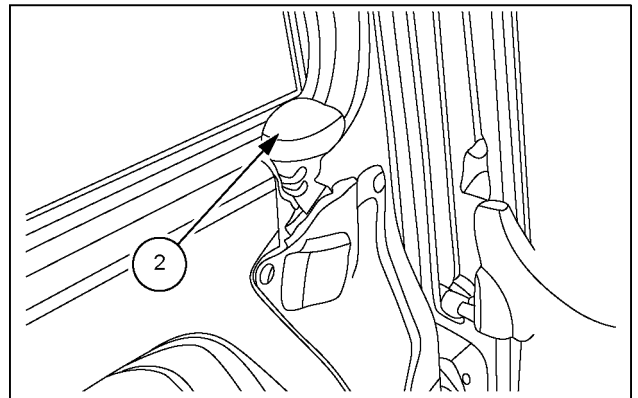

SMIL14CEX1650AB 2

The door can be latched in completely open position.

NOTICE: Never work leaving the door ajar. Before performing any work with the door open, make sure to lock it in the completely open position.

To unlatch the door, stop machine operation, set the gate lock lever to central position, and tilt the lever (3) downward.

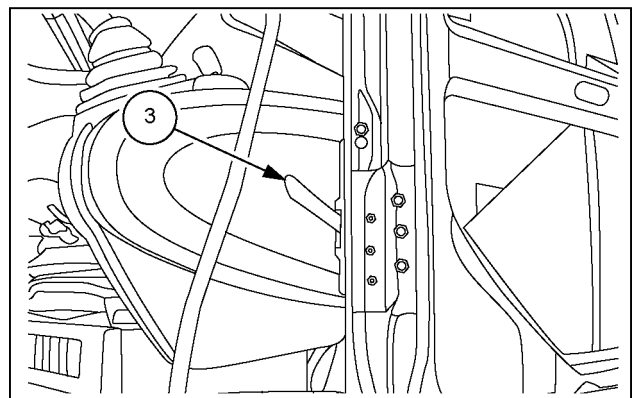

SMIL14CEX1651AB 3

Steps and access handles

⚠ WARNING

Fall hazard!
In order to enter or exit the cab, the upper structure frame must be in line with the undercarriage.
Failure to comply could result in death or serious injury.

W0225A

⚠ WARNING

Fall hazard!
Jumping on or off the machine could cause an injury. Always face the machine, use the handrails and steps, and get on or off slowly. Maintain a three-point contact to avoid falling: both hands on the handrails and one foot on the step, or one hand on the handrail and both feet on the steps.
Failure to comply could result in death or serious injury.

W0141A

⚠ WARNING

Fall hazard!
Clean the steps and access handles to remove all traces of grease, oil, mud, and ice (in winter).
Failure to comply could result in death or serious injury.

W0139A

To get in or out of the machine use the steps (1), the tracks and the access handles (2).

NOTICE: never use the left console, the left-hand control lever or the gate lock lever in place of the handles when getting on or off the operator's compartment.

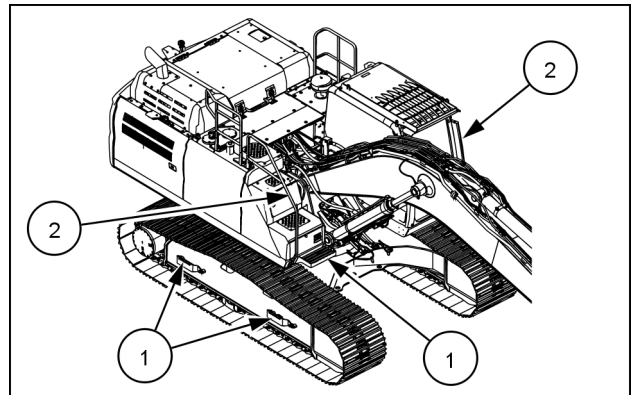

SMIL21CEX1372AA 4

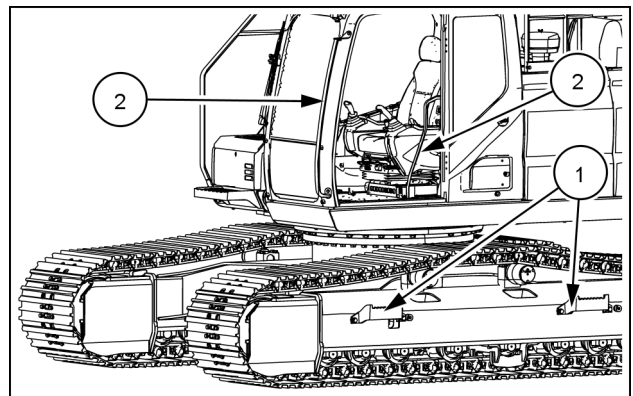

SMIL21CEX1373AA 5

Operator's seat

Operator's seat

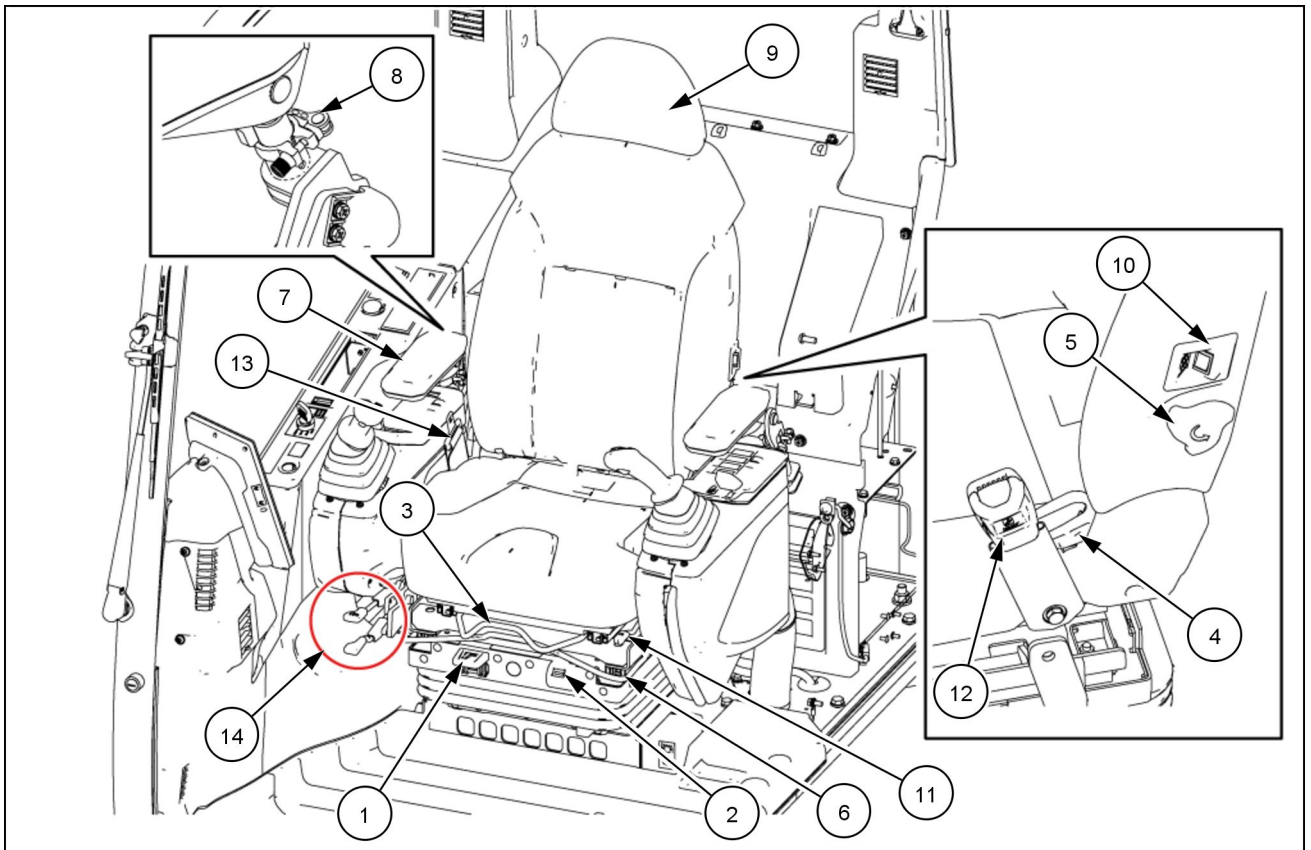

SMIL21CEX5534FA 1

- | | |
|--|--|
| 1. Combined height and weight adjustment | 8. Adjustment Section |
| 2. Weight adjustment indicator | 9. Headrest adjustment |
| 3. Fore and aft adjustment | 10. Seat heater |
| 4. Seat back angle adjustment | 11. Seat angle adjustment |
| 5. Lumbar support adjustment | 12. Seat belt buckle |
| 6. Seat and control arm assembly fore and aft adjustment | 13. Seat belt |
| 7. Armrest angle adjustment | 14. Left-hand side console and right-hand side console tilt adjustment |

In order to operate the machine correctly and with maximum efficiency and comfort, adjust the seat to suit the weight and size of the operator.

Combined height and weight adjustment

- Lower the handle (1) to decrease the rigidity of the suspension.
- Raise the handle (1) to obtain harder suspension.

NOTICE: the indicator (2) must be green when the operator is sitting on the seat.

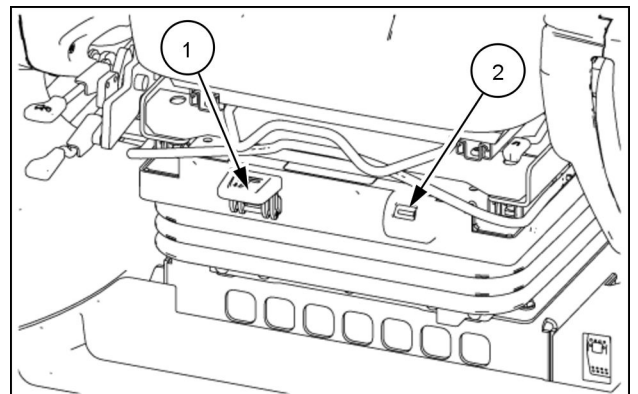

SMIL21CEX5535AA 2

Fore and aft adjustment

- Hold the control (3) in the raised position.
- Slide the seat to the required position.
- Release the control (3).

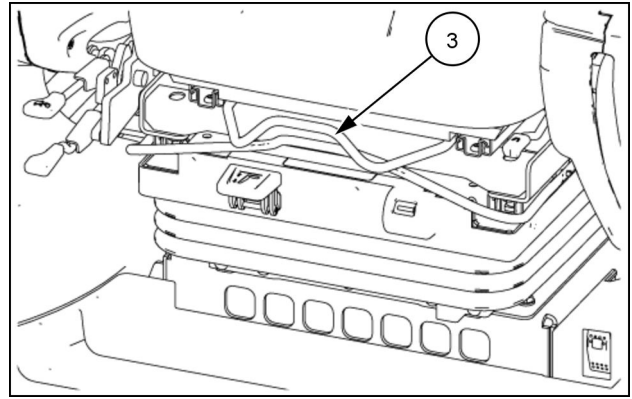

SMIL21CEX5535AA 3

Seat back angle adjustment

- Hold the lever (4) in the raised position.
- Move with the seat-back to the desired position.
- Release the lever (4).

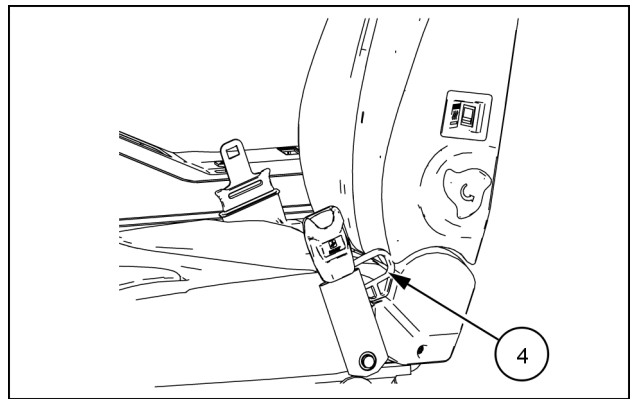

SMIL21CEX1377AA 4

Lumbar support adjustment

- Turn the dial (5) to adjust the bulge of the lumbar area in four levels.

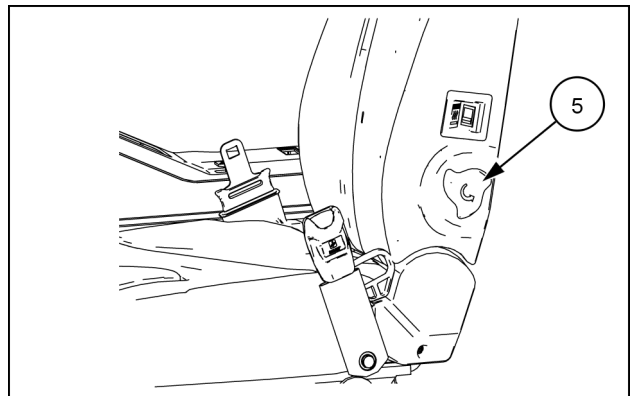

SMIL21CEX1377AA 5

Seat and control arm assembly fore and aft adjustment

- Pull the control (6) upwards.
- Slide the seat and control arm assembly to the desired position.
- Release the control (6).

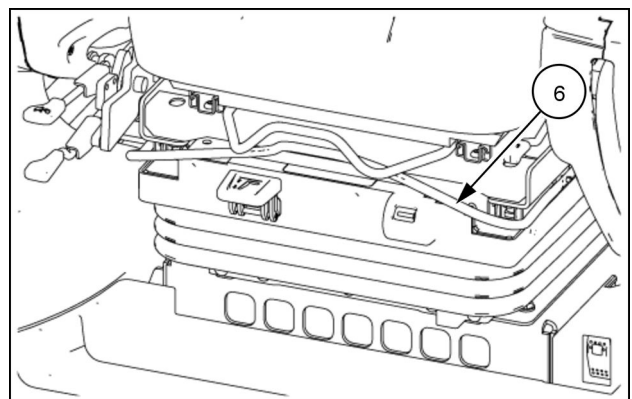

SMIL21CEX5535AA 6

Armrest angle adjustment

- Raise the armrest.
- Adjust the armrest to the desired angle using the knob (7).
- Lower the armrest.

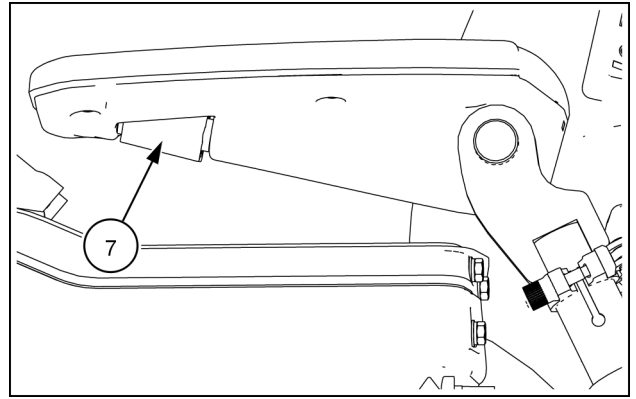

SMIL22CEX1277AA 7

Adjustment Section

- With the height adjustment lever (8) open, adjust the height.
- After the adjustment, close the adjustment lever (8) to lock the armrest in place.

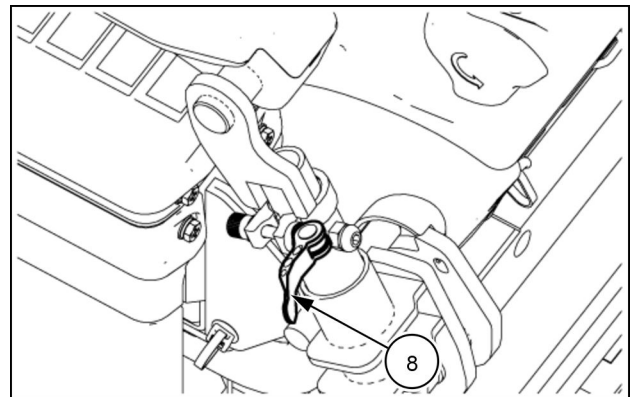

SMIL21CEX5536AA 8

- If the armrest is not firmly locked in place, tighten the bolt to adjust.

NOTE: Close the adjustment lever to lock the armrest in place. Do not lock the armrest in place by turning the adjustment lever.

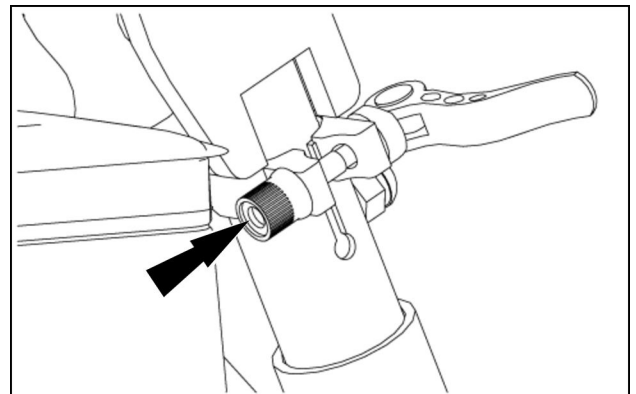

SMIL21CEX5537AA 9

Headrest adjustment

- The headrest (9) can be adjusted upwards and downwards.

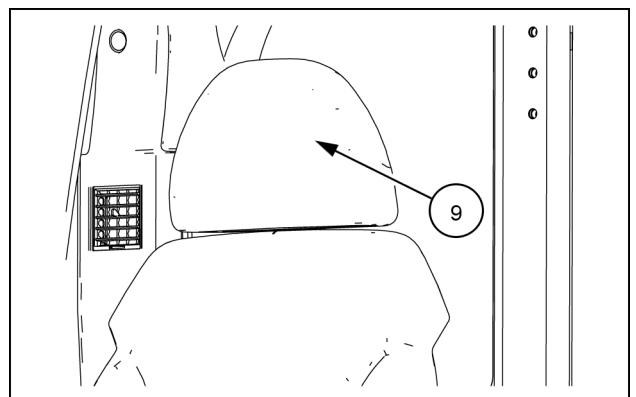

SMIL21CEX1380AA 10

Seat heater (If equipped)

- When the switch **(10)** is turned on, both the backrest and the seat area will be warmed.

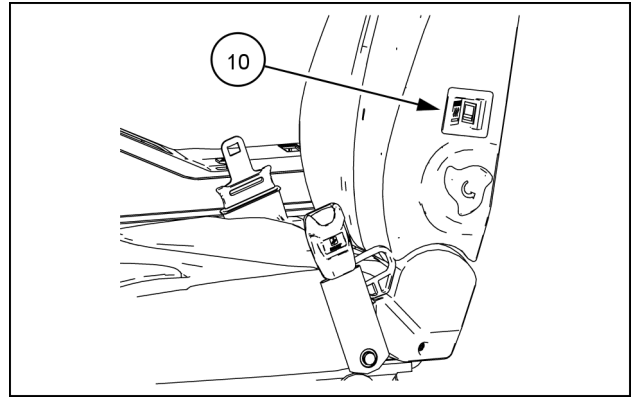

SMIL21CEX1377AA 11

Seat angle adjustment section (If equipped)

- The seat angle can be adjusted in 3 levels pulling the lever **(11)** up. When the seat reaches the proper angle, release the lever (6).
- When the seat reaches the proper angle, release the lever **(11)**.

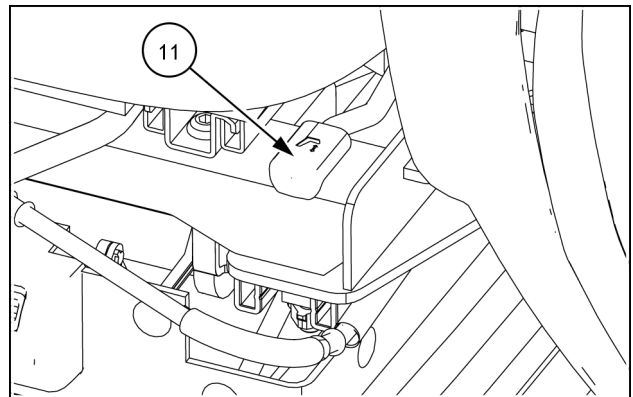

SMIL21CEX1382AA 12

Left-hand side console and right-hand side console tilt adjustment

The left-hand side console and right-hand side console can be tilted to the following angles: **-5°**, **0°**, **5°** and **10°**.

- Pull upwards the gate release lever **(1)** to release the lock.
- Adjust the angle of the consoles using the tilt adjustment lever **(2)**.
- Pull downwards the gate release lever **(1)** to lock the consoles in position.

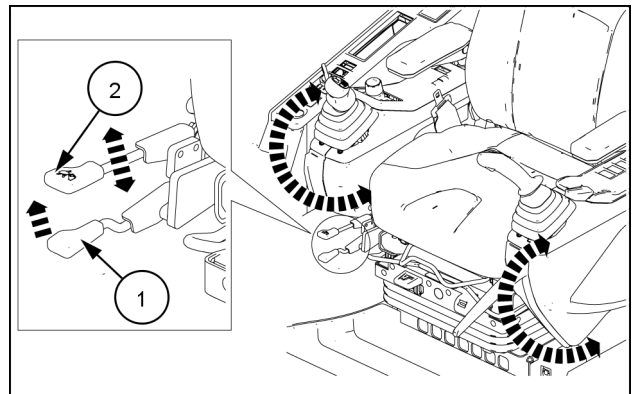

SMIL22CEX1269AA 13

Seat belt

⚠ WARNING

Equipment failure could cause accident or injury!

Always fasten the seat belt securely before you operate the machine. Inspect seat belt parts for wear and damage. Replace any and all worn or damaged parts of the seat belt prior to operation.

Failure to comply could result in death or serious injury.

W0046C

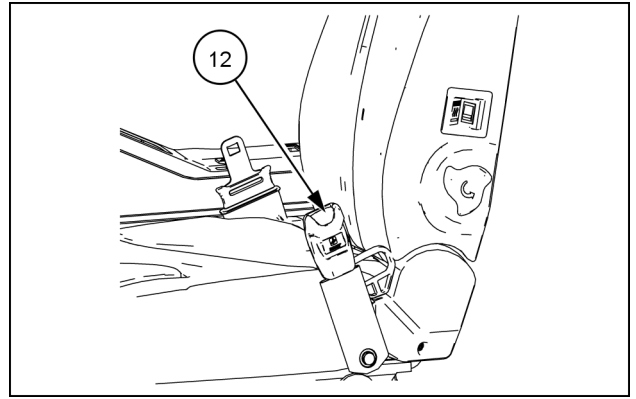

SMIL21CEX1377AA 14

- Sit comfortably on the operator's seat.
- Pull out a long section of belt.
- Engage the belt in the fastening system (12).

NOTE: if the section of belt pulled out is not long enough, release it, so it rolls up and then pull it out again.

To release the seat belt press down the releasing lever of the fastening system (9).

NOTICE: the seat belt must be kept clean. Use only soap and water to clean the belt, do not use bleach or dyes.

Forward controls

Forward controls

⚠ WARNING

Avoid injury!
 Inspect the work area or job site to make sure that machine operation can be done safely. Confirm that the lever operation is the same as indicated on the control pattern labels. If not, immediately change the machine control pattern or the label displayed to match the machine control pattern.
 Failure to comply could result in death or serious injury.

W1339A

Selection of control pattern

The machine can be equipped with a selector valve that allows to set two different patterns of the hydraulic controls of the front equipment. The patterns are called C and D. Refer to the next pages for description of the patterns.

NOTICE: Before starting machine operation, check that the operating pattern of control levers is consistent with the position selected on the valve. Furthermore, check that the pattern shown on the control mapping sheet into the cab is consistent with the operating pattern of the control levers.

To select the desired control pattern proceed as follows:

1. Lower the attachment to the ground, and stop the engine.
2. Open the front left-hand door. Read and understand the warning label (1) located inside the compartment.
3. Loosen the screw knobs (2) and remove the cover (3).

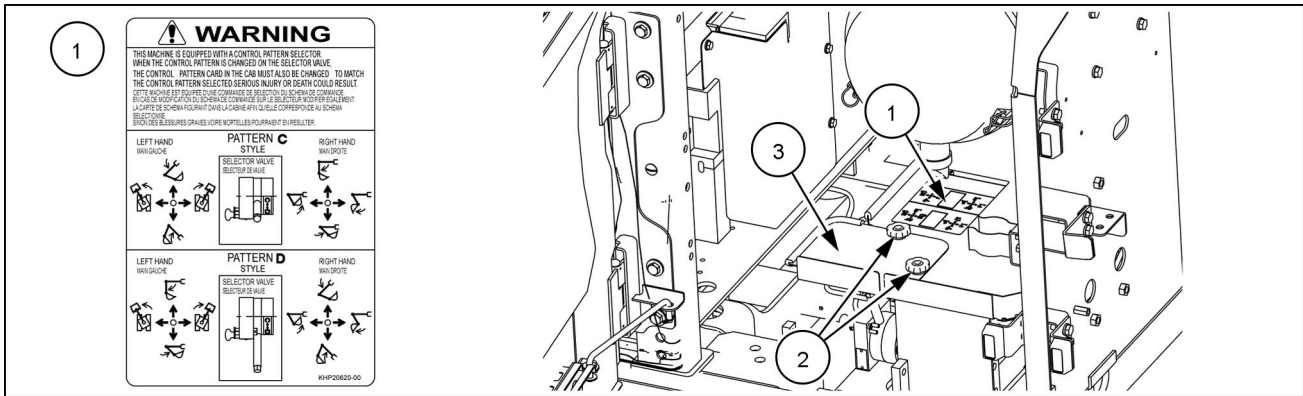

SMIL22CEX1275EA 1

4. Pull the locking knob (4) and move the lever (5) to set the desired control pattern C or D. Release the locking knob.

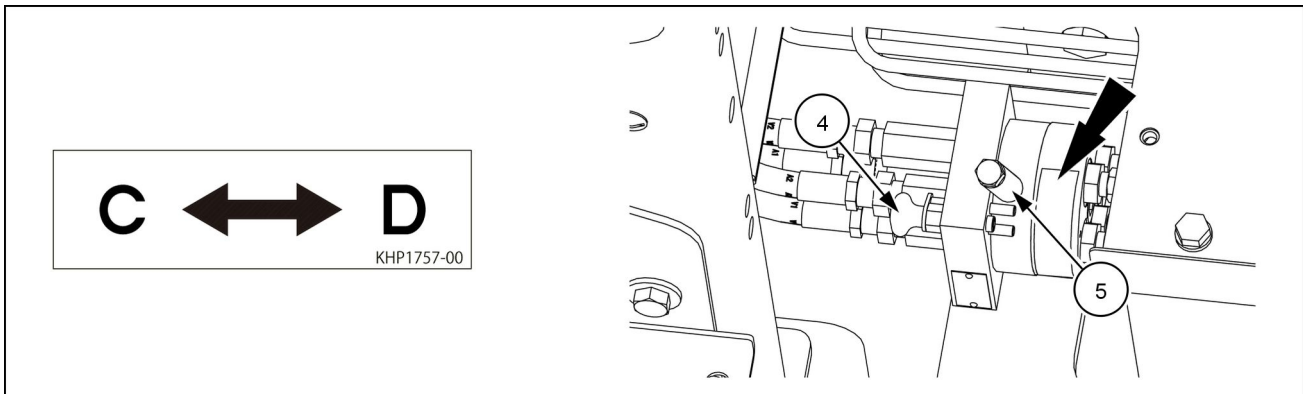

SMIL22CEX1276EA 2

5. Install the cover (3) and tighten the screw knobs (2).
6. Close the front left-hand door.

D position: ISO control pattern

Left-hand control lever:

1. The arm extends.
2. The arm retracts.
3. The upper structure swings to the left.
4. The upper structure swings to the right.

NOTE: The speed of movement of the arm or the swing depends on the control lever tilt angle. In the intermediate position two movements can be obtained simultaneously.

NOTE: when the upper structure swing control is released, the upper structure may continue to rotate due to the force of inertia. In this event, make allowance for the extra movement by releasing the control slightly earlier.

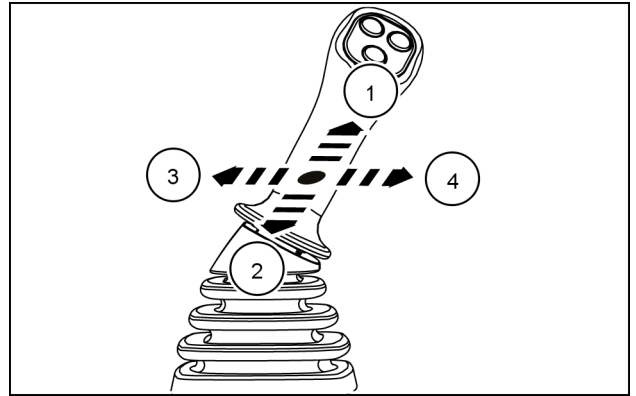

SMIL22CEX1941AA 3

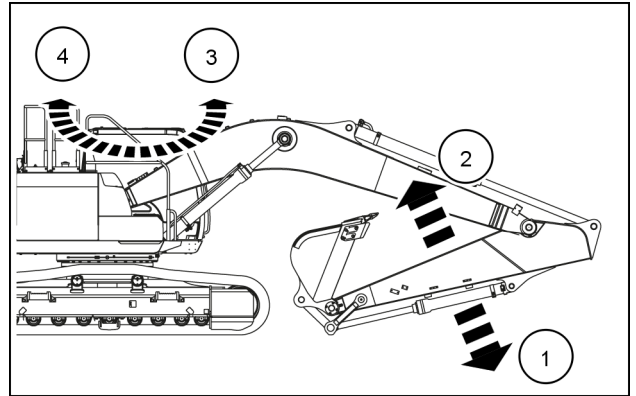

SMIL19CEX2049AB 4

Right-hand control lever:

5. The boom lowers.
6. The boom raises.
7. The bucket retracts (filling).
8. The bucket extends (dumping).

NOTE: The speed of movement of the boom or the bucket depends on the control lever tilt angle. In the intermediate position two movements can be obtained simultaneously.

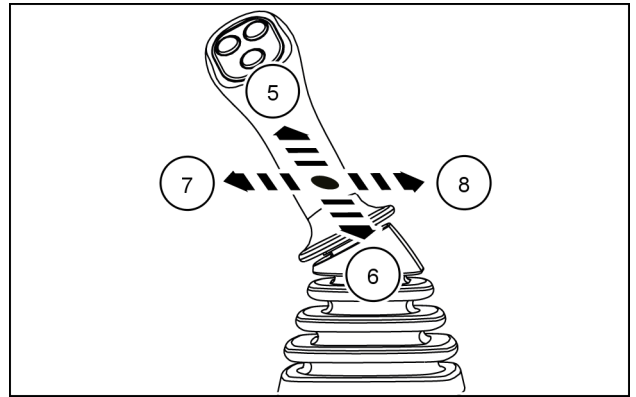

SMIL22CEX1942AA 5

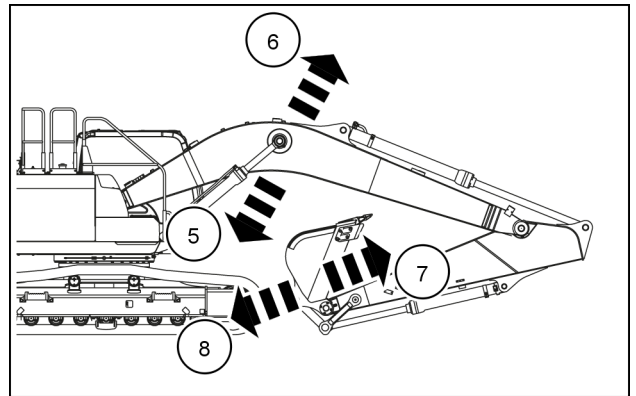

SMIL19CEX2048AB 6

C position: BHL control pattern

Left-hand control lever:

1. The boom lowers.
2. The boom raises.
3. The upper structure swings to the left.
4. The upper structure swings to the right.

NOTE: The speed of movement of the boom or the swing depends on the control lever tilt angle. In the intermediate position two movements can be obtained simultaneously.

NOTE: when the upper structure swing control is released, the upper structure may continue to rotate due to the force of inertia. In this event, make allowance for the extra movement by releasing the control slightly earlier.

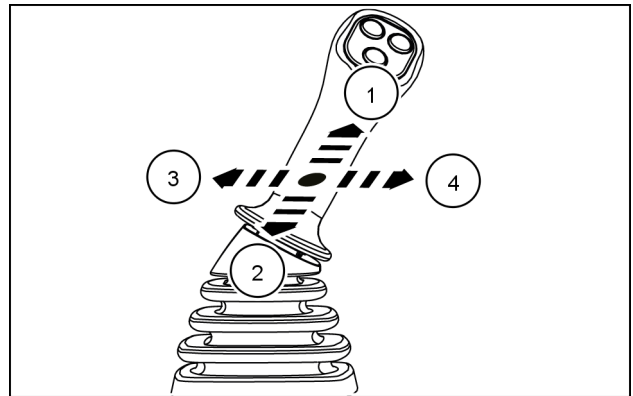

SMIL22CEX1941AA 7

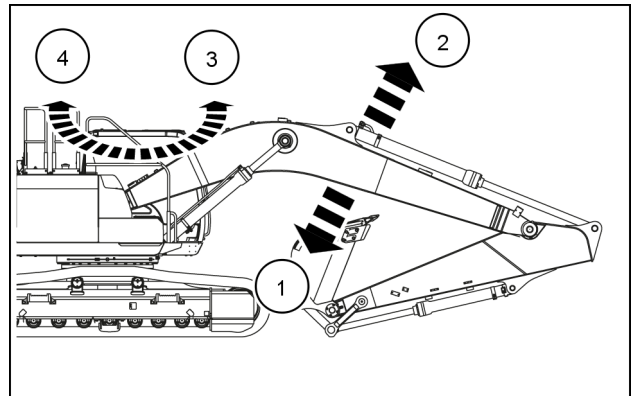

SMIL19CEX2049AB 8

Right-hand control lever:

5. The arm extends.
6. The arm retracts.
7. The bucket retracts (filling).
8. The bucket extends (dumping).

NOTE: The speed of movement of the arm or the bucket depends on the control lever tilt angle. In the intermediate position two movements can be obtained simultaneously.

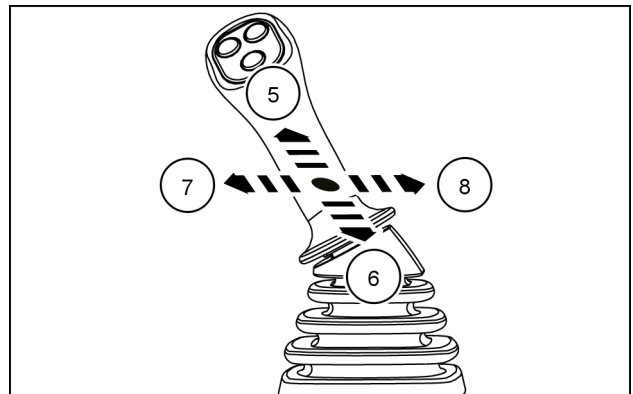

SMIL22CEX1942AA 9

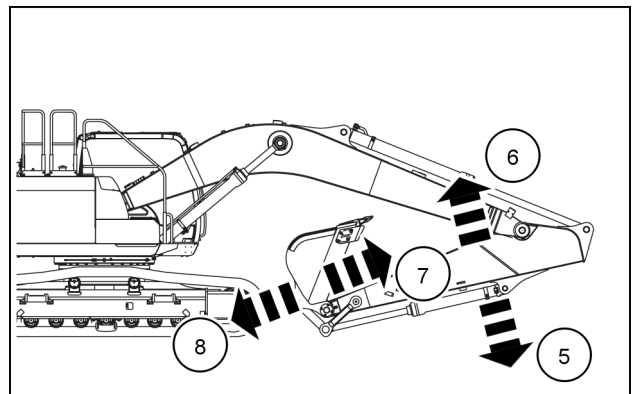

SMIL19CEX2048AB 10

Confirmation of the control pattern selection

1. Get onto the cab and make sure to place the sheet that maps the operating controls to the side corresponding to the selected control pattern (C or D).
2. Start the engine and check that the operating pattern of control levers is consistent with the position selected on the valve and shown by the mapping sheet.

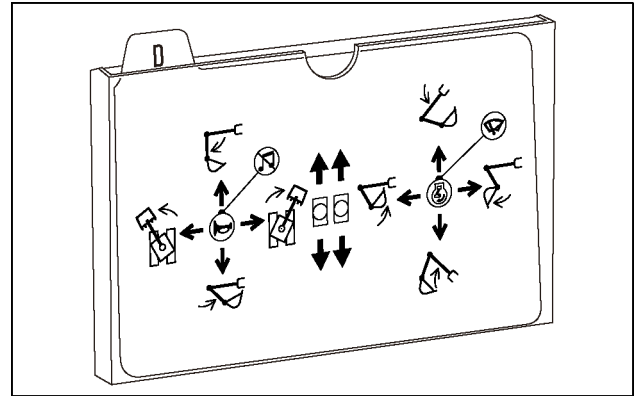

SMIL14CEX1671AA 11

Travel controls

1. Left-hand travel control lever and pedal
2. Right-hand travel control lever and pedal
3. Footrest
4. Single travel pedal

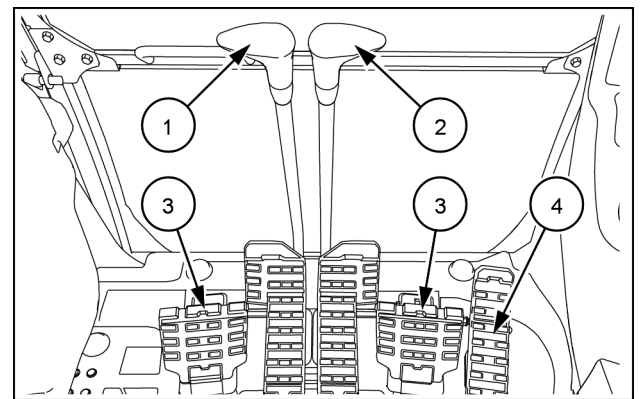

SMIL16CEX0262AA 12

The travel control levers and pedals are used to move the machine.

(N): neutral

(a) + (b): machine moves forward.

(c) + (d): machine moves backward.

(b) + (c): opposite simultaneous rotation of the tracks with consequent counterclockwise rotation of the machine around its centre axis.

(a) + (d): opposite simultaneous rotation of the tracks with consequent clockwise rotation of the machine around its centre axis.

(a), (b), (c), (d): positions to move one track only. Consequently the machine steers pivoting on the stationary track.

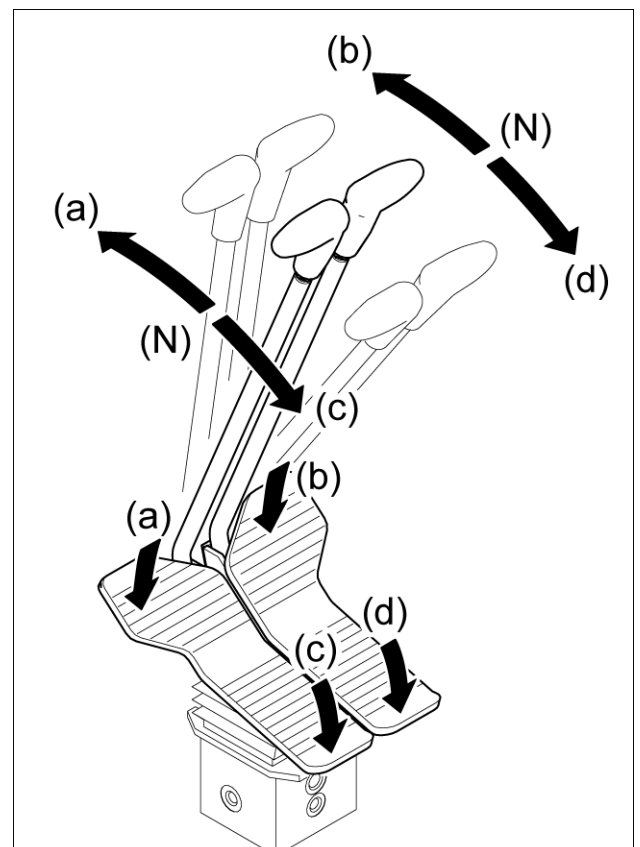

NH0159 13

The single travel pedal allows to move the machine straight forward or straight backward.

NOTE: The single travel pedal shall not be used together with the travel control levers and pedals. The single travel pedal function is alternative to the (a) + (b) function and the (c) + (d) function obtainable with the travel control pedals and levers.

NOTICE: always lock the single travel pedal when not in use.

Locking the single travel pedal

To lock the single travel pedal, engage the locking pin (1) in the locking hole (2).

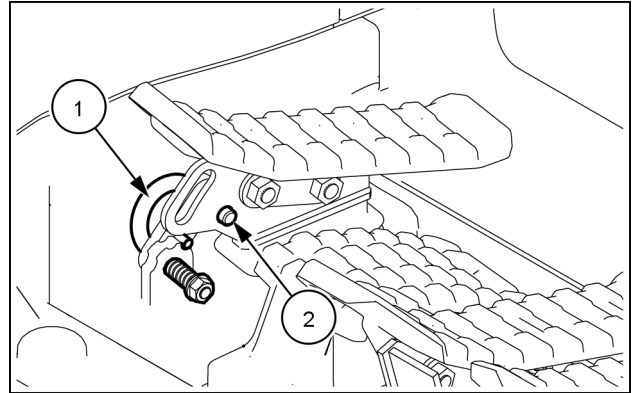

SMIL22CEX1962AA 14

To use the pedal, place the locking pin (1) in outward position.

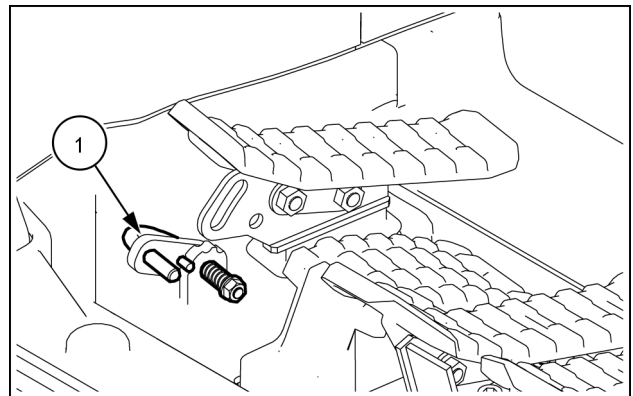

SMIL22CEX1964AA 15

NOTE: if the locking pin (1) is in position (3), only the forward travel is possible

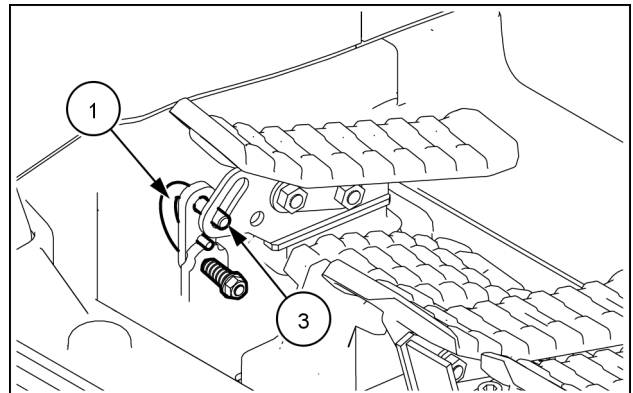

SMIL22CEX1963AA 16

Windshield

⚠ CAUTION

Pinch hazard!

Make sure you correctly follow the instructions in this manual when handling the windshield. If you do not handle the windshield correctly, it could slip and injure your fingers or hands.

Failure to comply could result in minor or moderate injury.

C0045A

Opening

1. If sun shield (1) is equipped, fold it back against the windshield and operate the lever (2). Hold the lower and upper handles (3) and carefully raise the windshield.

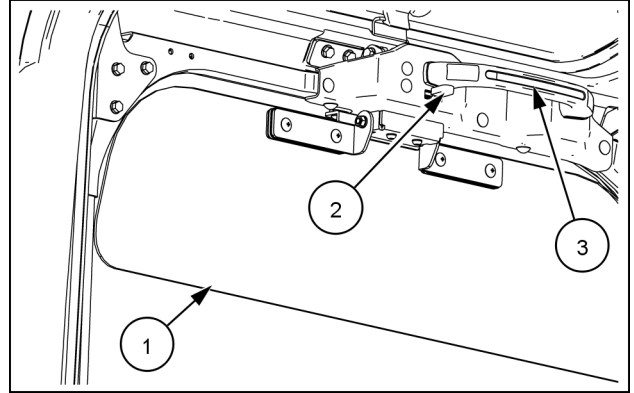

SML21CEX1413AA 1

2. Pull the windshield to the rear until it engages perfectly behind the cab.

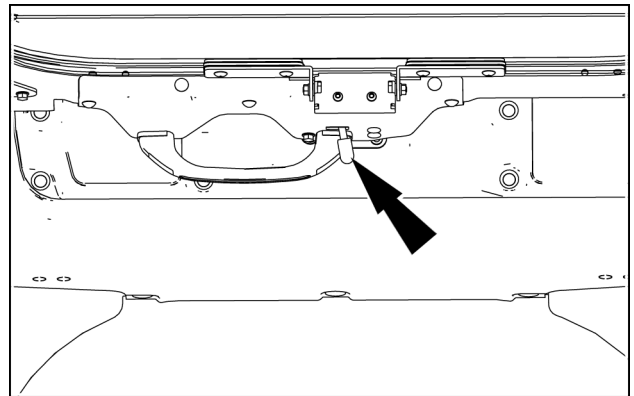

SML21CEX1414AA 2

Closing

1. Use the lever (2) to release the windshield.
2. Hold both handles (3) and carefully lower the windshield. Make sure the window is completely down.
3. Make sure the top of the windshield is correctly latched.

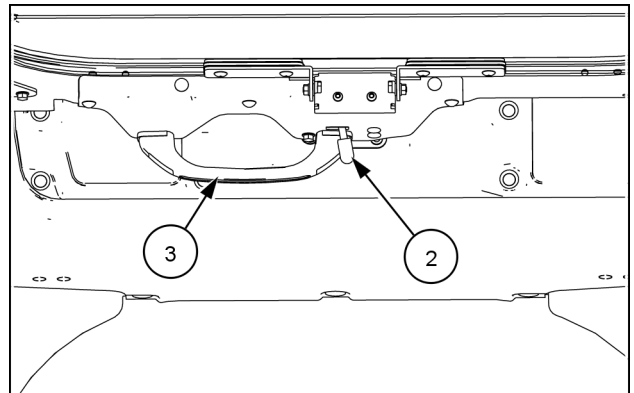

SML21CEX1414AA 3

Front lower window

The front lower window may only be removed when the windshield is open.

1. Remove the front lower window from its housing by sliding it upward.

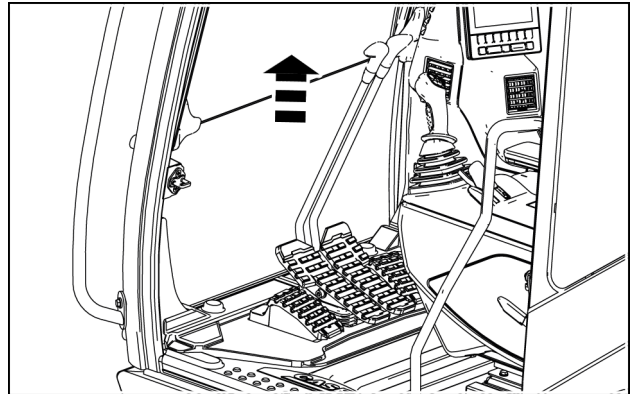

SMIL22CEX1934AA 1

2. Place the front lower window in the storage position provided to the left of the operator's seat and then engage it correctly with the three glass holders.

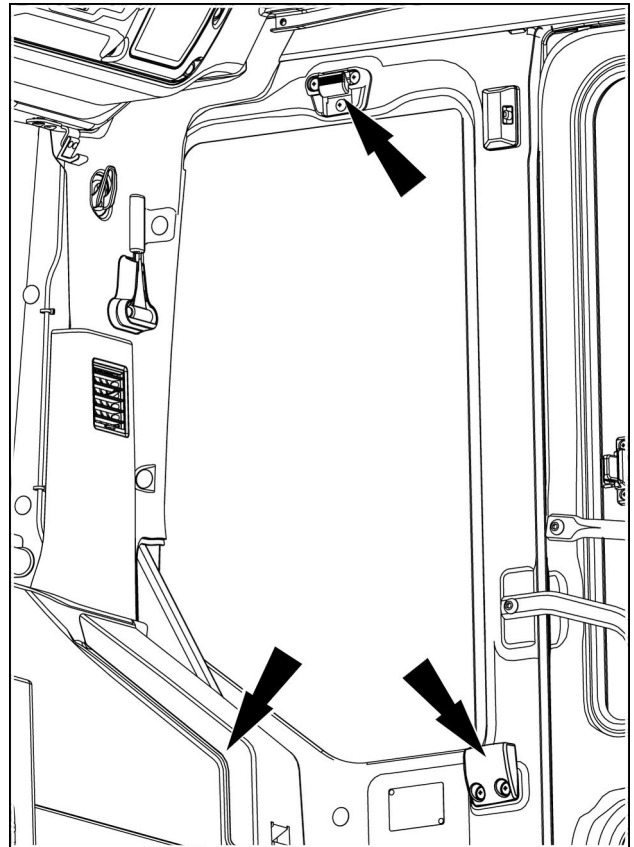

SMIL22CEX1932BA 2

Left-hand side controls

Left-hand side controls

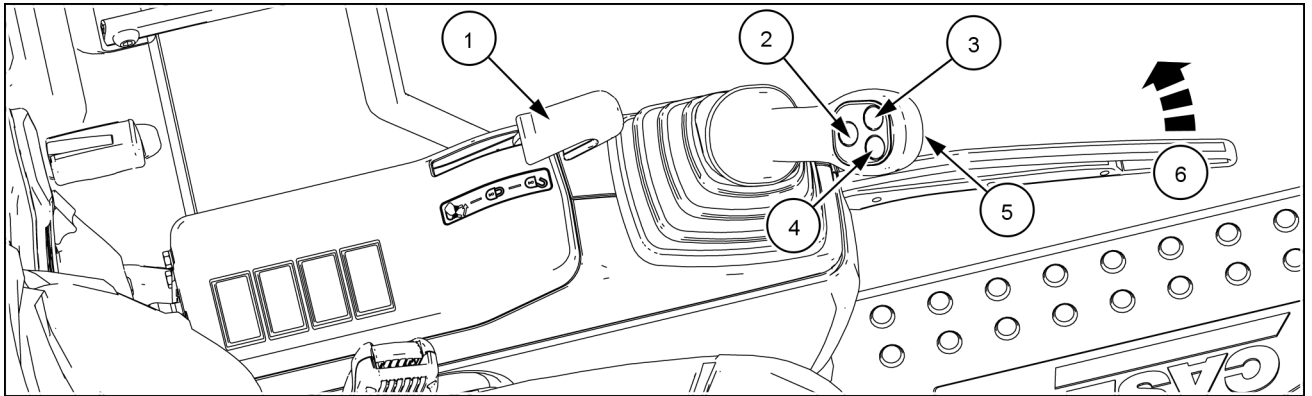

SMIL22CEX1960EA 1

(1) Gate lock lever.

(2) Horn button.

NOTICE: make sure to sound the horn before starting the engine and resuming machine operation.

(3) Camera select button: press the button to change the camera visualization on the monitor.

NOTE: the function of the buttons (3) , (4) , and (5) can be customized (refer to Instruments cluster section).

(4) Hands-free phone button: if a mobile phone is connected to the radio Bluetooth, press the button to answer a call.

(5) Radio mute button: the radio mute button is located underneath the control lever. Push the button to mute the volume. Push it again to resume the volume.

(6) Safety bar.

When the machine is equipped with the auxiliary low-flow hydraulic circuit, the left-hand control lever includes:

1. Proportional switch to operate double-acting hydraulic attachments.
2. ON/OFF button to operate the preferred operating direction of the double-acting hydraulic attachment
3. Horn button.

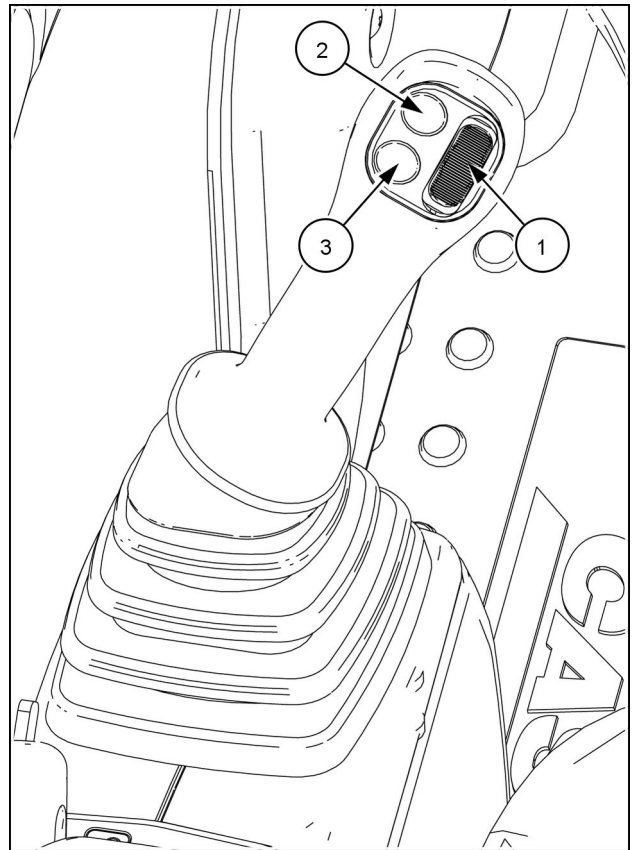

SMIL22CEX1296AA 2

Gate lock lever and safety bar

⚠ WARNING

Unexpected machine movement!

Before you leave the operator's compartment, the gate lock lever must be in the central position and the safety bar must be in the inward position.

Failure to comply could result in death or serious injury.

W1384A

The gate lock lever (1) allows to cancel the functioning of the control levers and pedals and operates the safety bar (2).

The safety bar prevents the operator from leaving the cab without previously operating the gate lock lever (1) to cancel the functioning of the control levers and pedals.

The gate lock lever operates on three positions:

- A. Forward position: when the gate lock lever (1) is in forward position, the safety bar (2) is in outward position. The attachment, the travel functions and the swing functions can be operated and the safety bar does not allow the operator to leave the cab.
- B. Central position: when the gate lock lever (1) is in central position, the safety bar (2) is in inward position inside the console. The attachment, the travel functions and the swing functions cannot be operated even if the engine is running. The operator may leave the cab if needed.
- C. Backward position: when the gate lock lever (1) is in backward position, the safety bar (2) is in inward position, all the functions are disabled and the left hand console is fully raised. The operator can thus easily get off the cab.

NOTE: set the gate lock lever to central position if just stopping machine operation without leaving the cab. Set the gate lock lever to backward position when ending machine operation and leaving the machine.

NOTE: the engine must be started with the gate lock lever in central position. If the gate lock lever in forward position, the engine does not start.

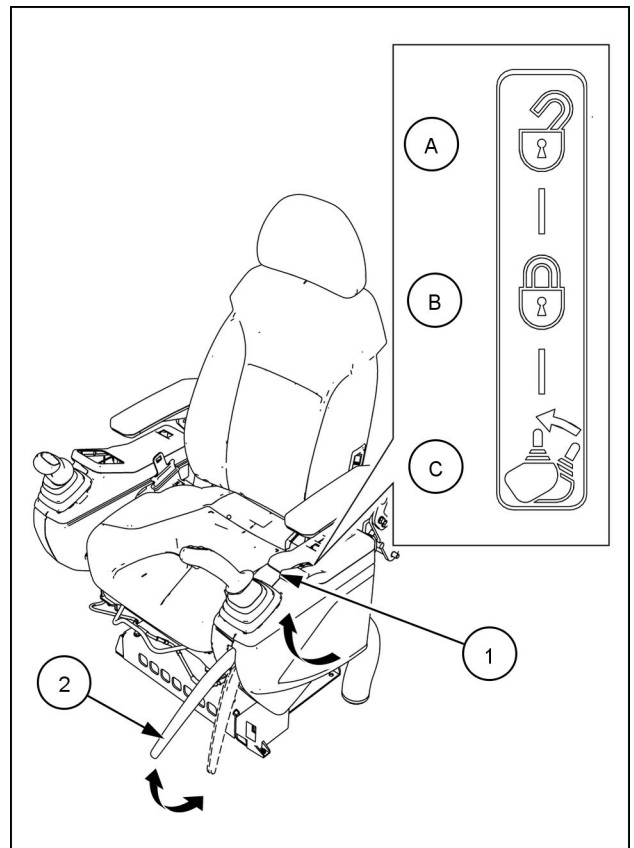

SMIL21CEX1390BA 1

Auto Operation Lever Lock Function

If the operator unintentionally released the gate lock (5) when the control levers (1), proportional switches (2), travel control levers and pedals (3), or special attachment operation pedal (4) is in operation, the pilot pressure supply is cut off to lock machine operations in order to prevent unexpected movements of the machine.

NOTICE: The purpose of the auto operation lever lock function is to reduce accidental damage by preventing the operator from performing any unintended operations. Regardless of whether it is intentional or not, this function is activated if any operations are performed before the gate lock is released. Ensure that the gate lock is released before operating the machine. In some cases, even when this function is activated, the machine may not stop immediately and move a little before it stops. Note that this function may not be activated under the following conditions. A machine failure has occurred. The hydraulic oil temperature is low. (Always warm up the engine before operating the machine.) The viscosity of the hydraulic oil in use is higher than that of the recommended genuine hydraulic oil. (Use a hydraulic oil with the correct viscosity.)

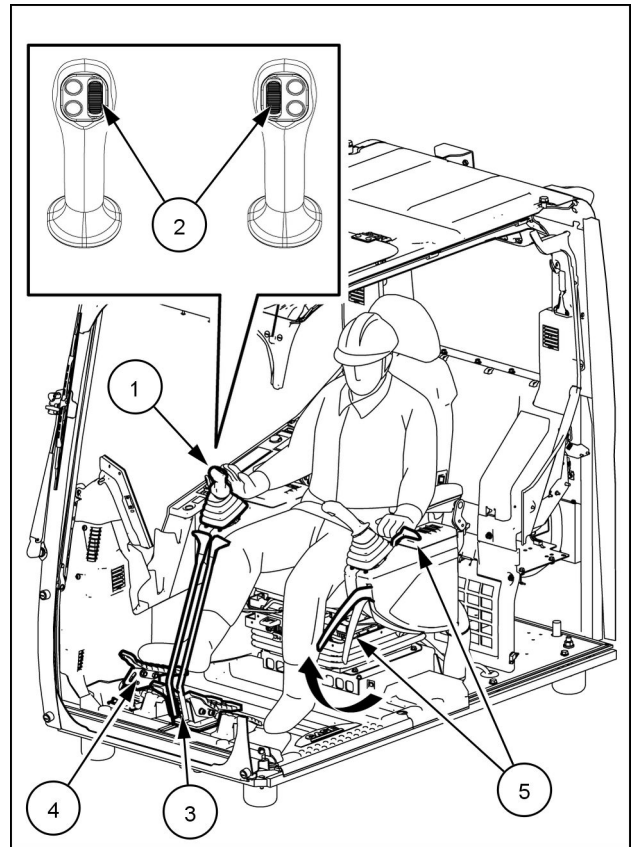

SMIL21CEX4351BA 2

When the auto operation lever lock function is activated, an alarm sounds and the icon (1) and text message "AUTO LEVER LOCK ACTIVE" (2) are displayed. Also, the messages "RELEASE CONTROL LEVER AND PEDAL" and "SET GATE LOCK LEVER TO CENTRAL POSITION" are displayed on the NOTIFICATIONS screen (3). These remain displayed until this function is deactivated.

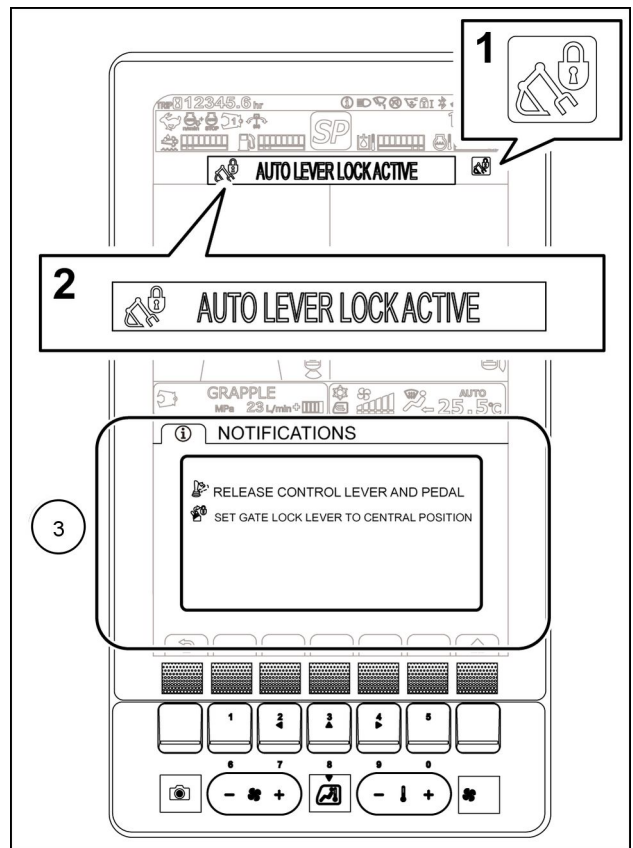

SMIL21CEX4352BA 3

While this function is activated, the machine does not move even when the gate lock lever is in the normal operating position (1) (with the safety bar raised) and the control lever or operation pedal is operated. To enable the attachment, travel, and swing operation functions again, return the gate lock lever to the nonoperation position (2) (with the safety bar stored in the console) and check that the control levers and operation pedals are in the neutral position, then move the gate lock lever to the normal operating position (1) (with the safety bar raised) again. Also, if the machine is subjected to strong vibrations during operation, in rare cases, this function may be activated and the machine can stop suddenly. If that happens, return the gate lock lever to the non-operation position (2) (with the safety bar stored in the console) and check that the control levers and operation pedals are in the neutral position, then move the gate lock lever to the normal operating position (1) (with the safety bar raised) again.

NOTE: Before setting the gate lock lever to the normal operating position (1) (with the safety bar raised), check that all operation levers and operation pedals are in the neutral position. If any one of them is not in the neutral position, the machine may move suddenly, causing death or serious injury.

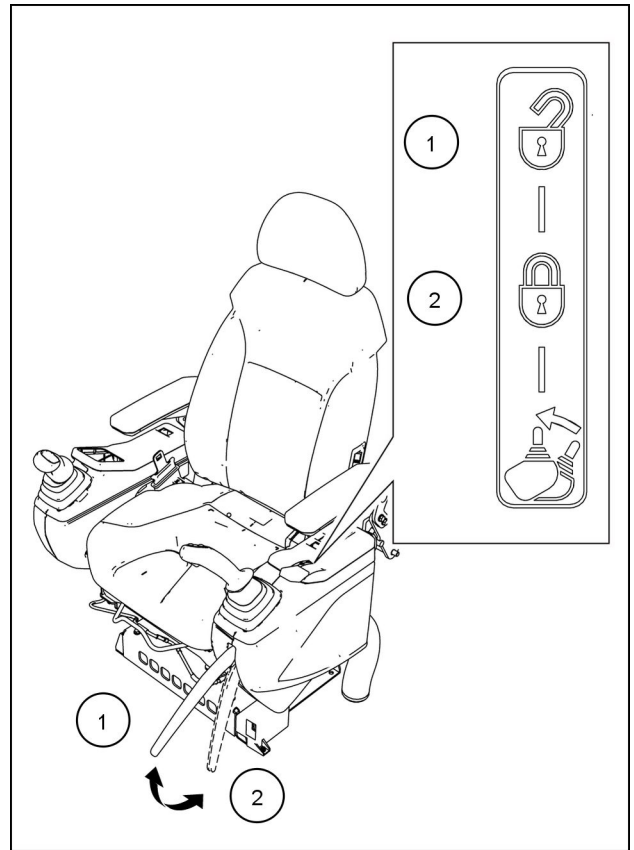

SML21CEX1390BA 4

NOTE: When the icon (3) and text message "AUTO LEVER LOCK IS NOT AVAILABLE" (4) are displayed, the auto operation lever lock function is temporary disabled. Our service engineer can disable the function. If this is displayed, contact your local dealer or the certified service plant.

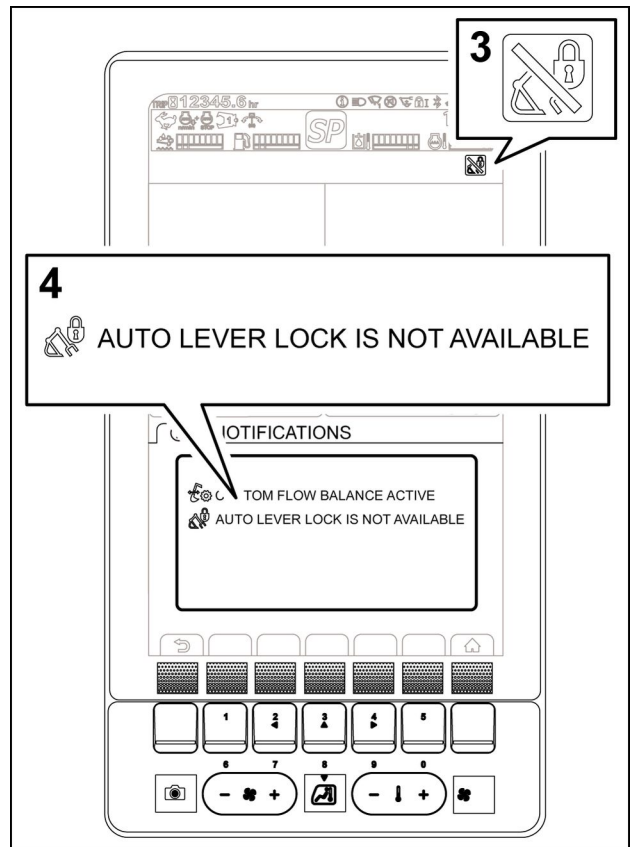

SML21CEX4353BA 5

NOTE: When the icon (5) and text message "ELEC. PROBLEM" (6) are displayed, the auto operation lever lock function is not working properly. If this is displayed, contact your local dealer or the certified service plant.

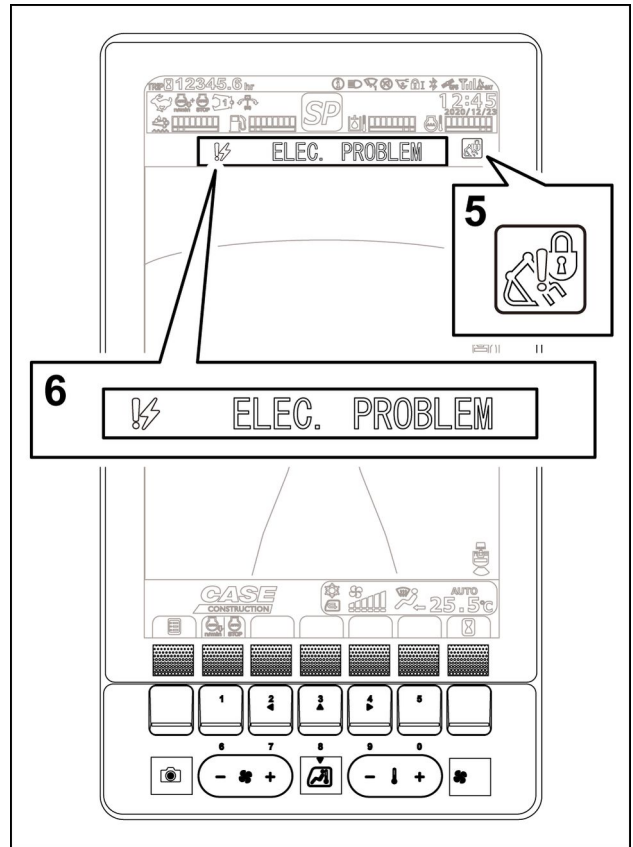

SMIL21CEX4354BA 6

Cab internal lighting

The room lamp allows to have internal lighting inside the cab. The room lamp has a control switch with three operating positions:

- OFF
- DOOR
- ON

When the switch is set in DOOR position, the room lamp turns on automatically when the door is opened, and turns off automatically when the door is closed.

NOTE: If the door is left open for more than **30 s**, the lamp is forcedly turned off in order to prevent drain of the battery charge.

The ON position of the switch allows to turn on the room lamp only if the starter key is set in ACC or ON position.

NOTICE: Never leave the room lamp switch in ON position. The battery charge may be drained out. As the need for lighting ends, set the switch to OFF or DOOR position.

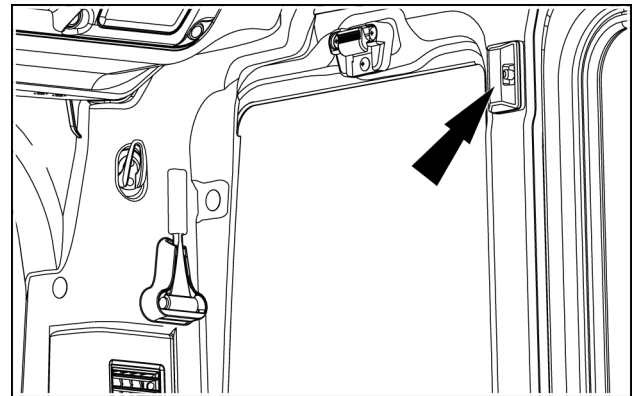

SMIL22CEX1282AA 1

Emergency exit hammer

Located on the left-hand cab, use the hammer to break the rear window, and then push the window strongly and escape outside.

Consult your CASE CONSTRUCTION dealer for window installation.

NOTICE: Do not break the rear window except when it is absolutely necessary, such as to escape in an emergency.

NOTICE: Do not place anything in front of the window. Doing so may obstruct an emergency escape.

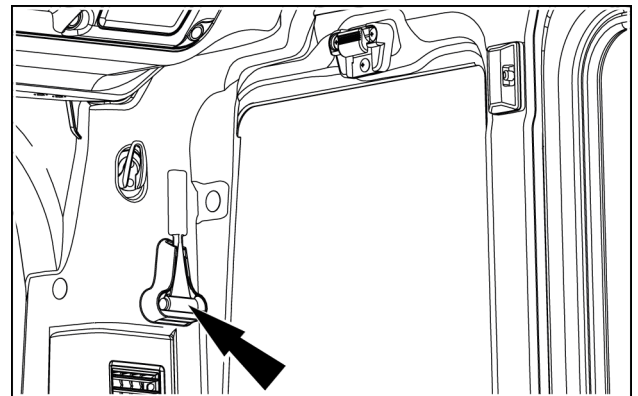

SMIL22CEX1282AA 1

Sliding windows on door

The two windows on the cab door can be opened singularly or simultaneously. Release the lock and slide each window in order to open it.

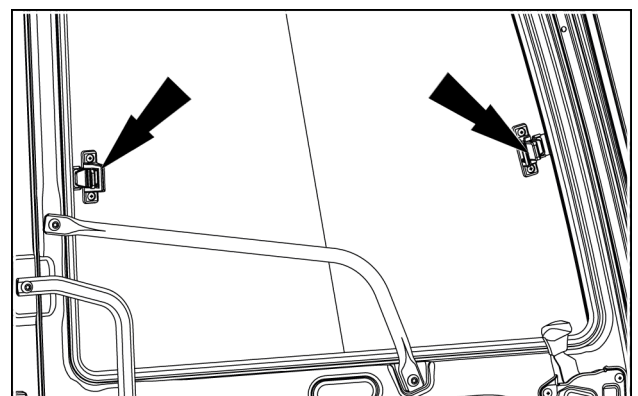

SMIL22CEX1933AA 1

Right-hand side controls

Right-hand side controls

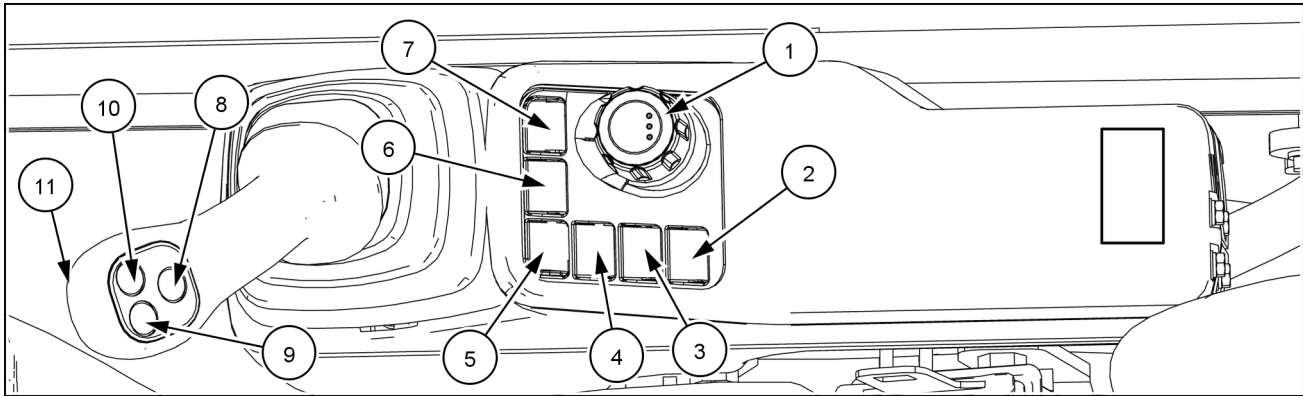

SMIL21CEX1390EA 1

(1) Engine speed throttle and work mode selector (refer to "Instrument cluster" section).

(2) Windshield washer button (refer to "Instrument cluster" section).

(3) Wiper button (refer to "Instrument cluster" section).

(4) Working lights button (refer to "Instrument cluster" section).

(5) Travel mode button (refer to "Instrument cluster" section).

(6) Attachment select button (optional function, refer to Chapter 9).

(7) Lifting mode button (optional function, refer to Chapter 9).

(8) Engine low idle speed button: the engine low idle speed button enables to set the engine speed to low idle at a touch without moving the engine speed throttle. If operating at engine speed different from low idle, press and release the engine low idle speed button to get down the engine speed to low idle. Press and release the button again to resume the engine speed set by the engine speed throttle.

(9) Air conditioner button: press the button to turn the air conditioner ON or OFF.

(10) Windshield washer button.

(11) One-touch wiper button: press and hold down the button to operate the wiper.

NOTE: the function of the buttons **(9)**, **(10)**, and **(11)** can be customized (refer to "Instruments cluster" section).

When the machine is equipped with an auxiliary high-flow hydraulic circuit, the right-hand control lever includes:

1. Proportional switch to operate double-acting hydraulic attachments.
2. ON/OFF button to operate single-acting hydraulic attachments.
3. Engine low idle speed button.

NOTICE: Do not operate controls for auxiliary high-flow hydraulic circuit without setting any flow rate/pressure combination. The circuit would work by default at maximum pressure, and this may lead to severe damages to the attachment. For the setting procedure of auxiliary high-flow hydraulic circuit, refer to Chapter 9.

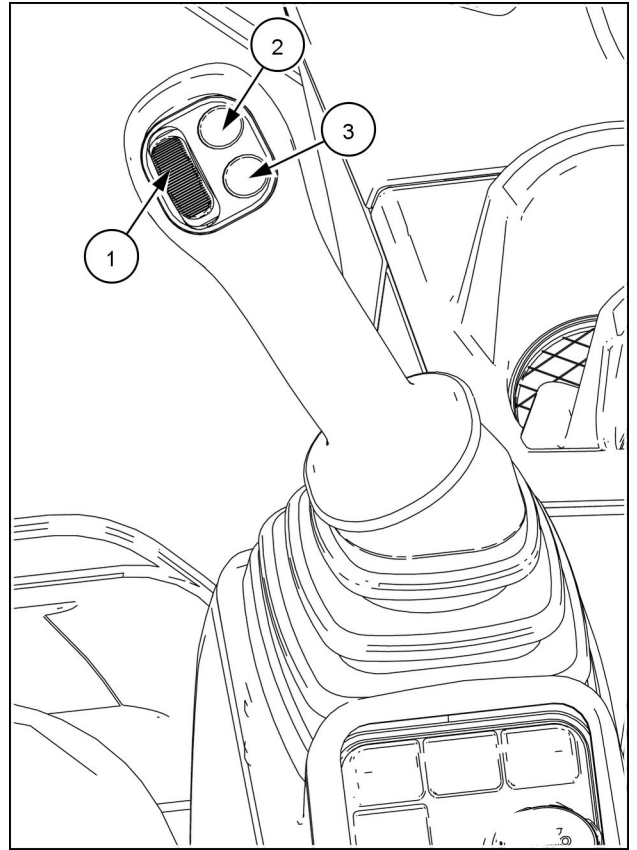

SML22CEX1295AA 2

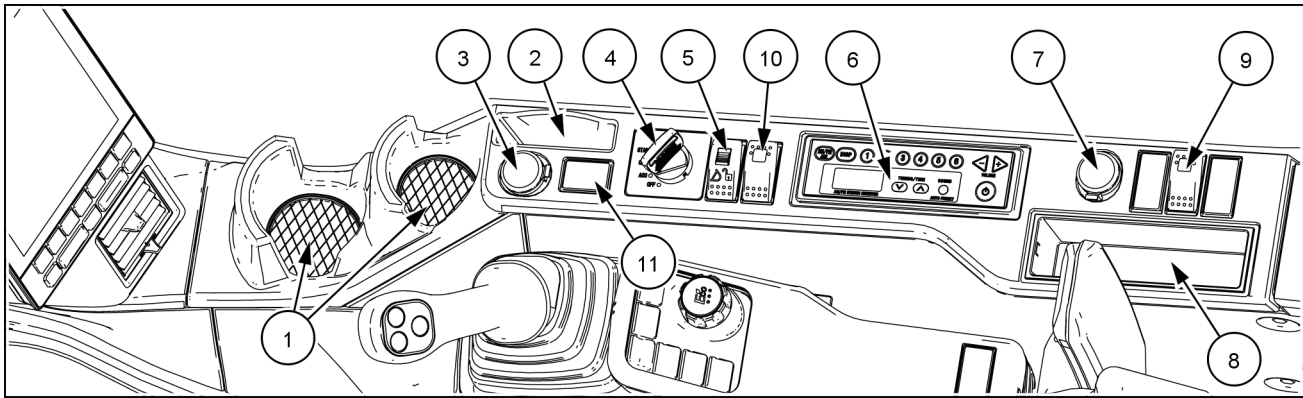

SMIL22CEX1938EA 3

(1) Cup holders

(2) Smartphone holder

(3) **12 V** power supply socket: the device is active with the starter key in ON position, or while the engine is running.

NOTICE: connect only **12 V** devices to the socket. Connecting devices functioning at different voltage can cause damages to the device itself and to the electrical system.

(4) Starter switch (4 positions): ON (contact), START (engine ignition), OFF (engine shut-down) and ACC (accessory current supply).

NOTICE: when the starter key is in ON position, if the security function is enabled, it will be necessary to enter the password. Refer to page 4-1.

NOTE: the starter key is also used to lock the cab door, the DEF/ADBLUE® tank cover, the engine hood, the front storage box, the side doors and the fuel tank cap.

(5) Hydraulic quick coupling system activation switch (optional, refer to Chapter 9).

(6) Radio.

(7) **24 V** power supply socket: the device is active with the starter key in ON position, or while the engine is running.

NOTICE: connect only **24 V** devices to the socket. Connecting devices functioning at different voltage can cause damages to the device itself and to the electrical system.

(8) Storage tray.

(9) Around lighting switch (optional): the around lighting switch allows to activate the around lighting system installed on the cameras. Press the back side of the switch to activate the lighting. Press the front side of the switch to deactivate the lighting.

NOTE: the around lighting system activates as the working lights are turned on.

(10) Free swing button: the button sets the condition of swing stop. If the free swing is activated the swing stop is delayed. Press the button to activate the free swing function. The free swing icon appears on the monitor. Press the button again to deactivate the function.

The free swing function is intended to be used especially for load handling application to avoid loads from slinging.

The free swing function is automatically disabled when stopping the engine.

NOTICE: avoid working on a slope with the free swing function active. The swing becomes hard to stop.

NOTICE: when parking on a slope, never activate the free swing function from the machine parking position. The machine may start to swing because the swing parking brake is released.

(11) USB port and AUX port.

Instrument cluster

(1) Solar radiation sensor

If you place anything on the solar radiation sensor (on the console at the front right of the operator's seat), accurate measurement of the temperature inside the operator cab becomes impossible. Do not place anything on the solar radiation sensor.

(2) Monitor display

Displays the clock, fuel gauge, coolant temperature gauge, and oil pressure/temperature gauge. Displays the function selection status. Displays the status of the machine. Displays camera images. Displays the service status of the machine.

(3) Monitor switches

Used to select the machine status. Used to switch the monitor display. Used to operate the air conditioner.

(4) Air conditioner vents

The air conditioner vents control the air flow circulation and direction. The air conditioner vents are opened/closed and their direction controlled manually.

NOTICE: While the air conditioner is being used, the air vents must be left open.

(5) USB external input

Used by service engineers for maintenance. Do not connect a commercially available USB flash drive.

NOTICE: If the USB port cover is not securely fastened, water may enter the inside of the monitor and cause damage.

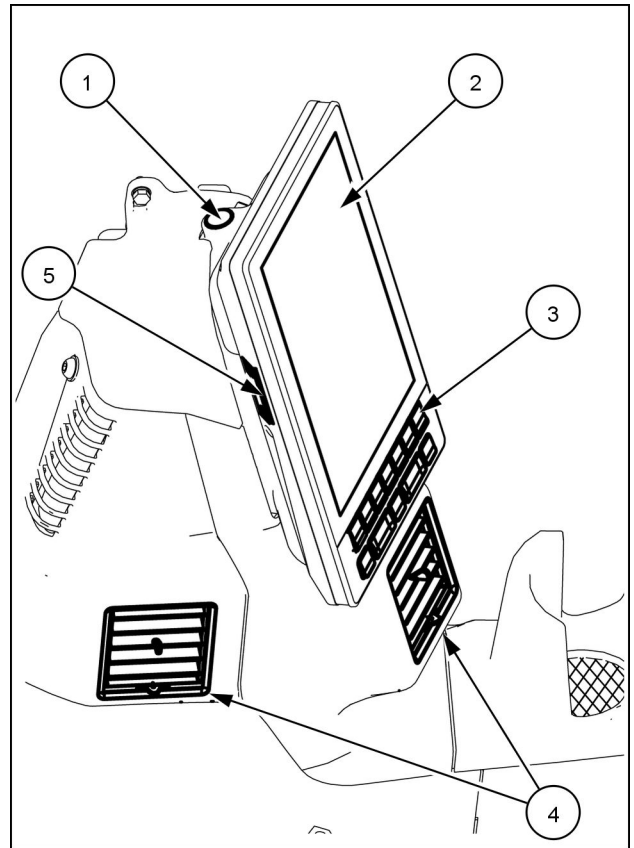

SMIL21CEX3489BA 1

Monitor switches

The monitor switches are used to operate or select the machine devices and monitor display or to operate the air conditioner.

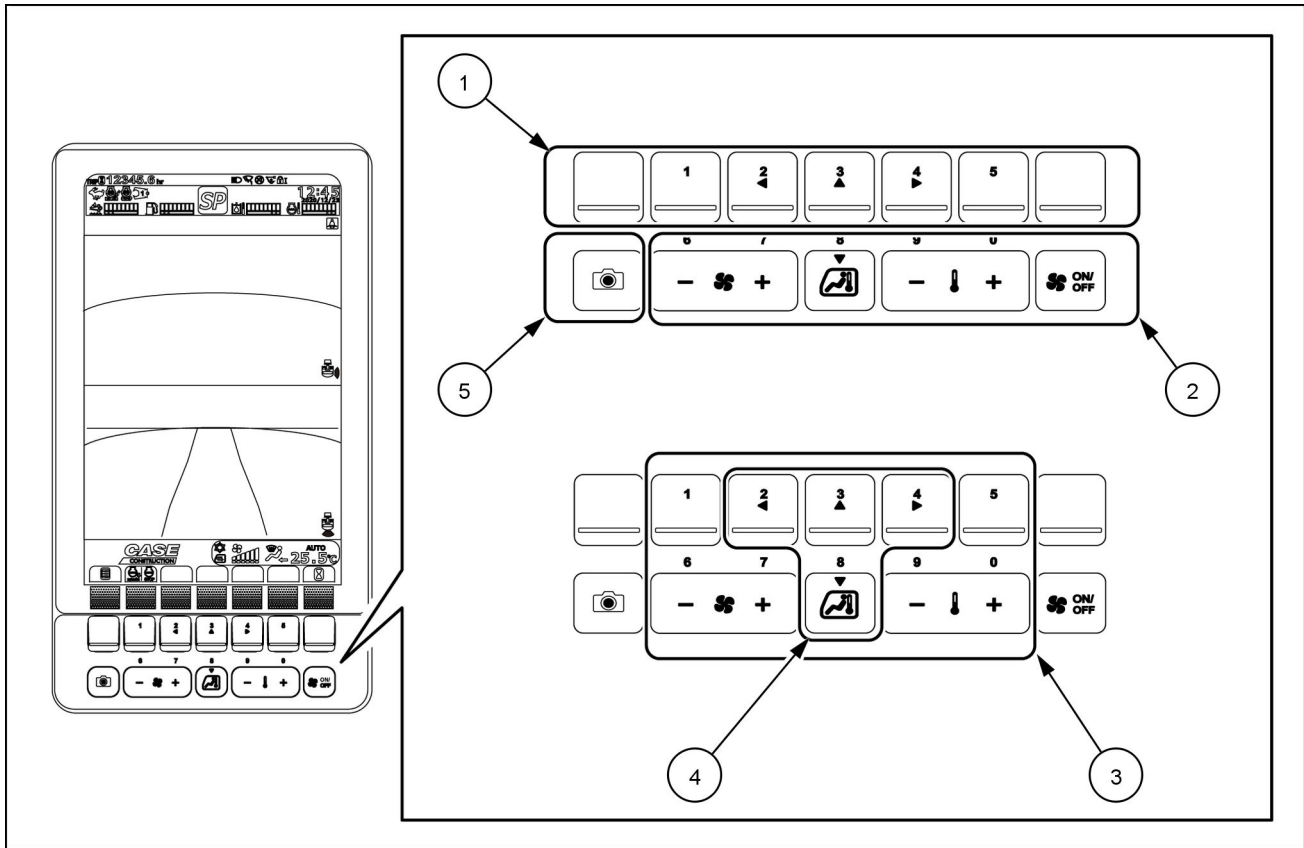

SMIL21CEX3490FA 2

1. Area used when operating function keys (Switch icons are displayed on the monitor.)
2. Area used when operating the air conditioner
3. Area used when operating the numeric keys
4. Area used when operating the cursor keys
5. Camera select switch

Monitor display

There are 2 modes for monitor display:

Normal display mode: Displays the machine status and camera images during operation.

User information mode: Allows you to view machine information and to configure various settings.

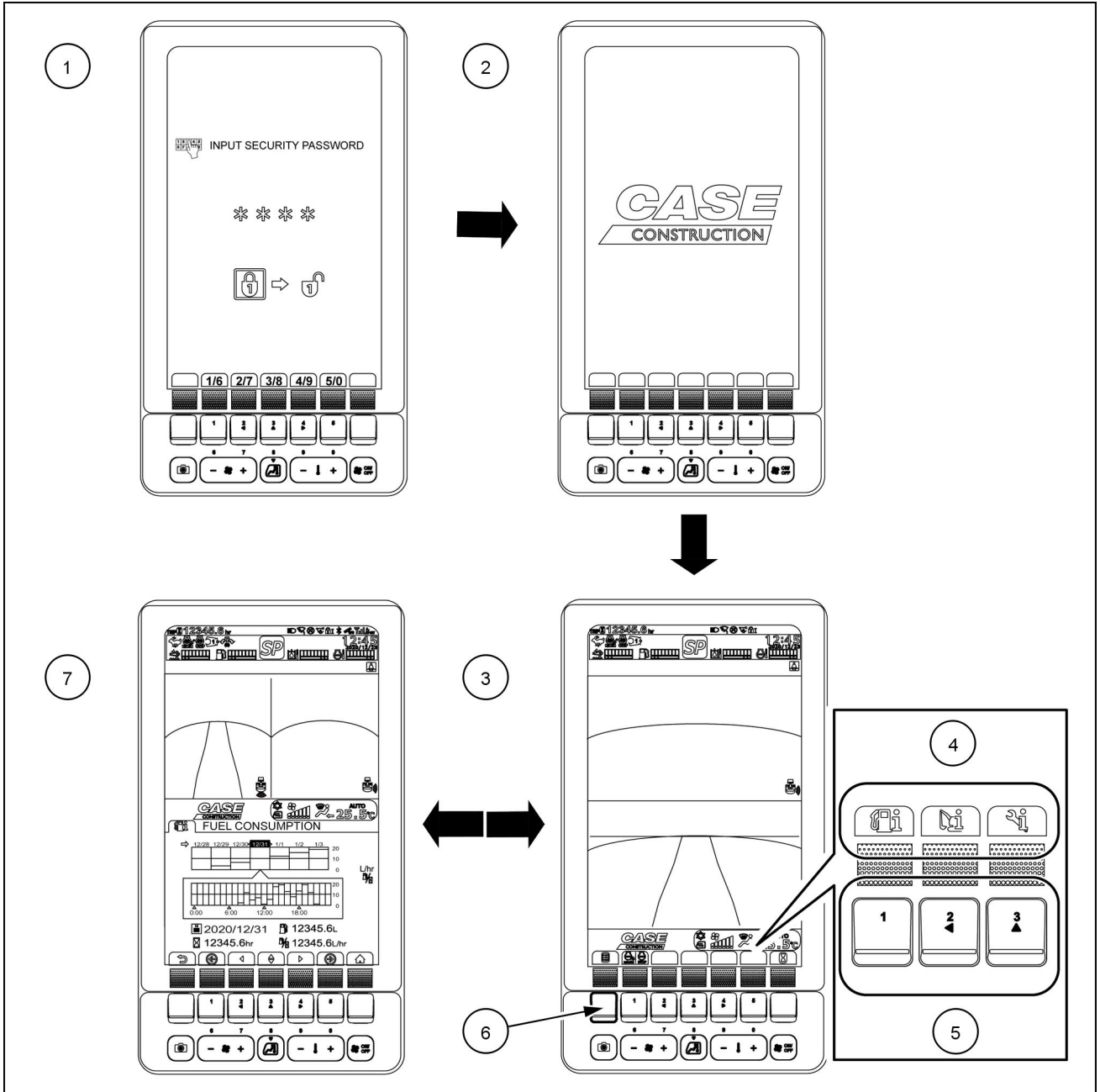

SML21CEX3491GA 3

NOTE: The monitor displays the status of the machine during operation. If any abnormality occurs, it notifies the operator immediately with a message and the buzzer. It is not used in start-up inspections and service.

Screen transitions. If security is set up, the security password entry screen (1) is displayed.

NOTE: For information on setting up security, consult your CASE CONSTRUCTION dealer.

When the security password is entered correctly, the initial screen (2) is displayed, then the system enters the normal display mode (3).

For details on how to enter the security password, refer to "Using Security Function". When you press the function switch (6) for displaying the menu items, menu items are displayed on the function switch tabs (4). Press the function switch (5) under the menu item you want to display to switch to the user information mode (7).

User information mode

Switching screens in user information mode: press the function switch **(14)** to change the icons displayed on the function switch tabs. When you press user information mode function switches **(1)** - **(13)** for the information you want to view or set, their respective information screen is displayed.

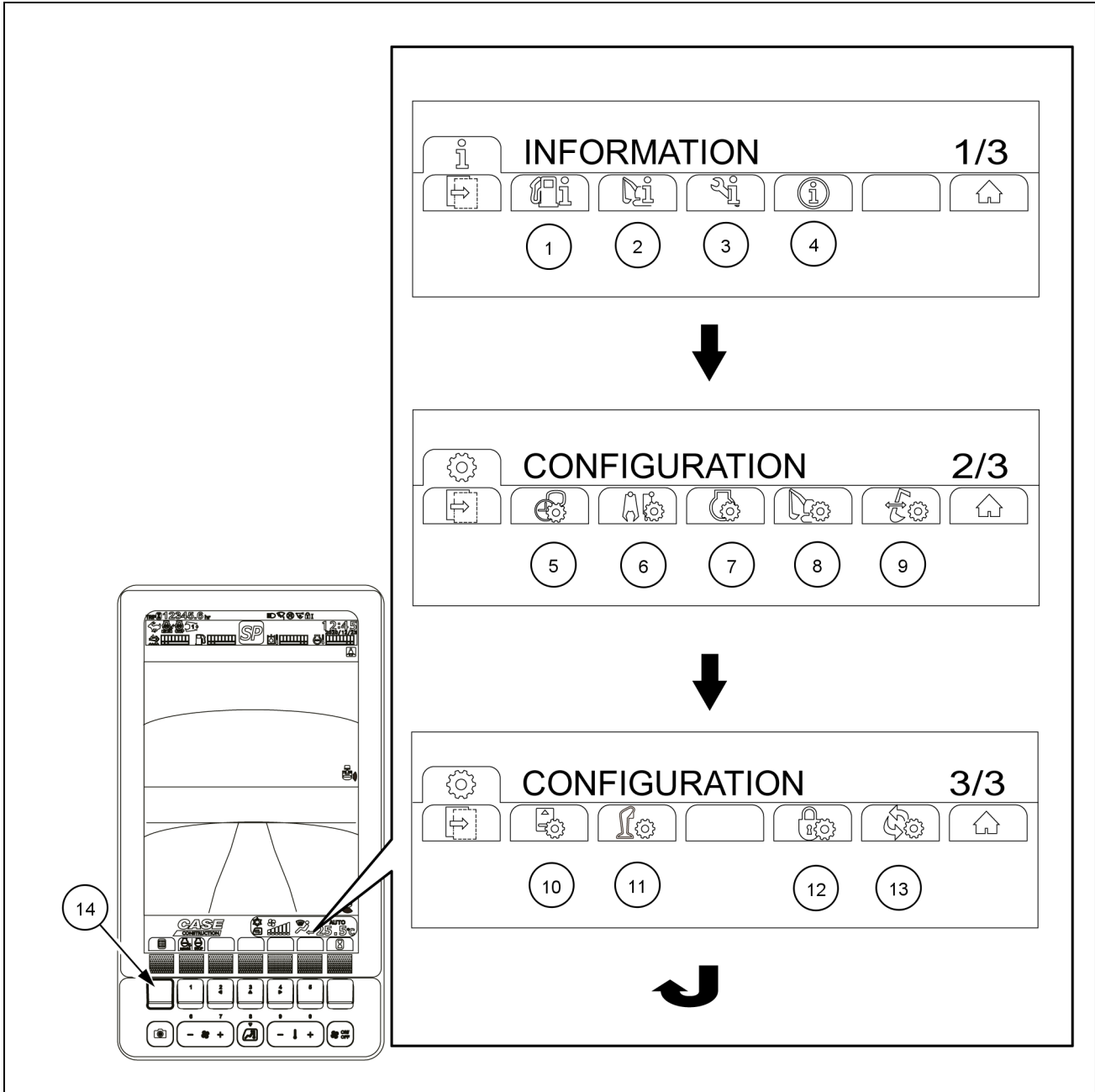

3 - CONTROLS AND INSTRUMENTS

1	FUEL CONSUMPTION	Enables you to view the fuel economy for the past 7 days.
2	MACHINE INFORMATION	Enables you to view the machine status in detail.
3	TIME UNTIL REPLACEMENT	Enables you to view the information on the time for replacing the periodic replacement parts.
4	NOTIFICATIONS	Enables you to view the information that the operator needs to know.
5	DISPLAY CONFIGURATION	Enables you to configure the screen brightness, camera, and date/time settings.
6	AUXILIARY HYDRAULICS	Enables you to switch between Breaker and Crusher, manage operations according to the model, and set the pressure and flow rate. (Refer to Chapter 9)
7	ATS CONFIGURATION	Enables you to view and change the ATS settings
8	FUNCTION CONFIGURATION	Enables you to configure settings for functions related to energy-saving and safety.
9	CUSTOM FLOW BALANCE	Enables you to adjust the flow balance according to the end attachment to be used.
10	MONITOR SWITCHES LAYOUT	Enables you to create shortcuts for frequently used menu screen items on the function switch tab in normal display mode.
11	KNOB SWITCHES LAYOUT	Enables you to change the switch function of the control levers switches.
12	PASSCODE SETTING	Enables you to change the passcode.
13	FACTORY SETTING	Enables you to reset the settings on the menu screen to the factory settings all at once.

Display area

There are 4 display areas in the [Normal display mode] (1) and 5 display areas in the [User information mode] (2).

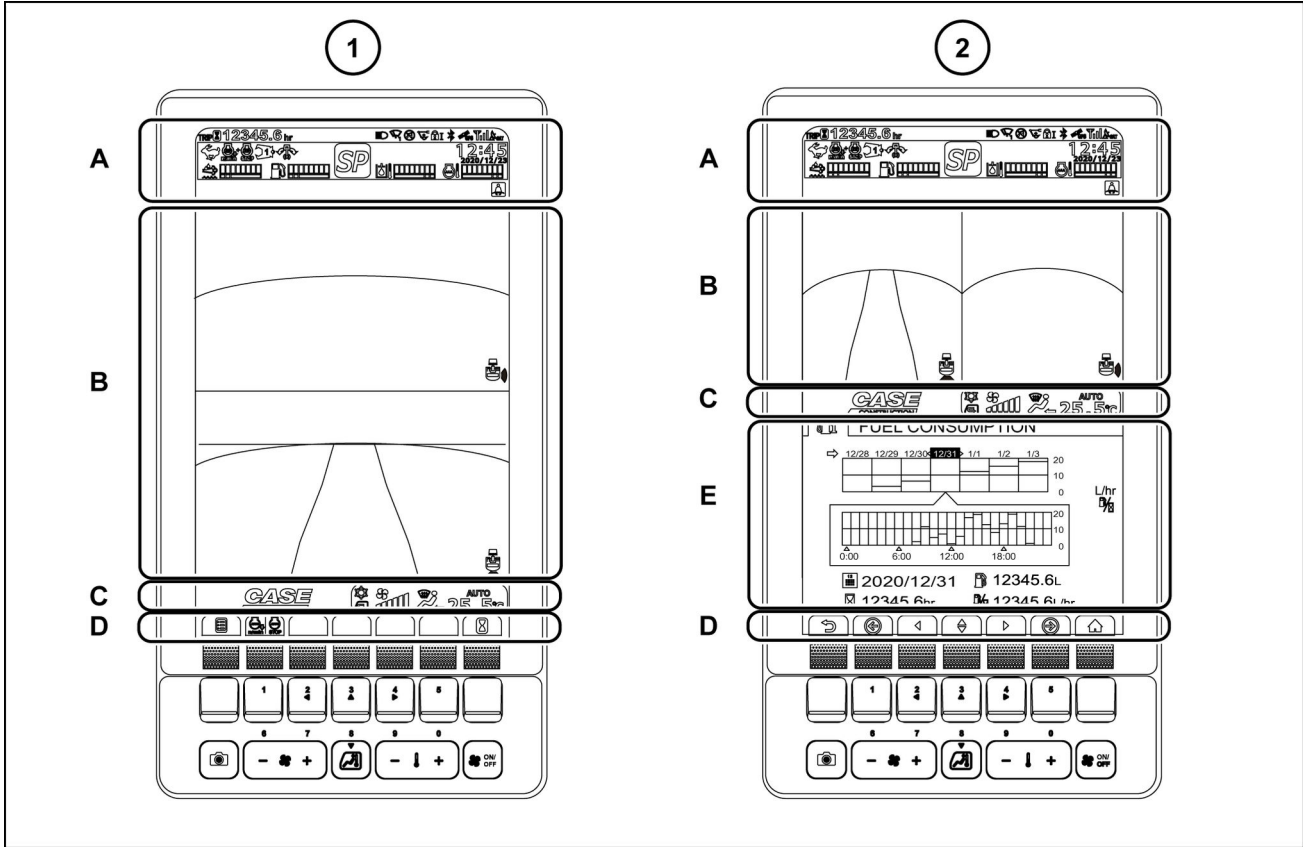

SMIL21CEX3492FB 5

(A) Icon display area

(B) Camera display area

(C) Information display area

(D) Function switch tab display area

1. Displays operation switch icons

2. Displays user information modes. The function switch layout in normal display mode can be changed in MONITOR SWITCHES LAYOUT.

(E) User information screen display area

Icon display area

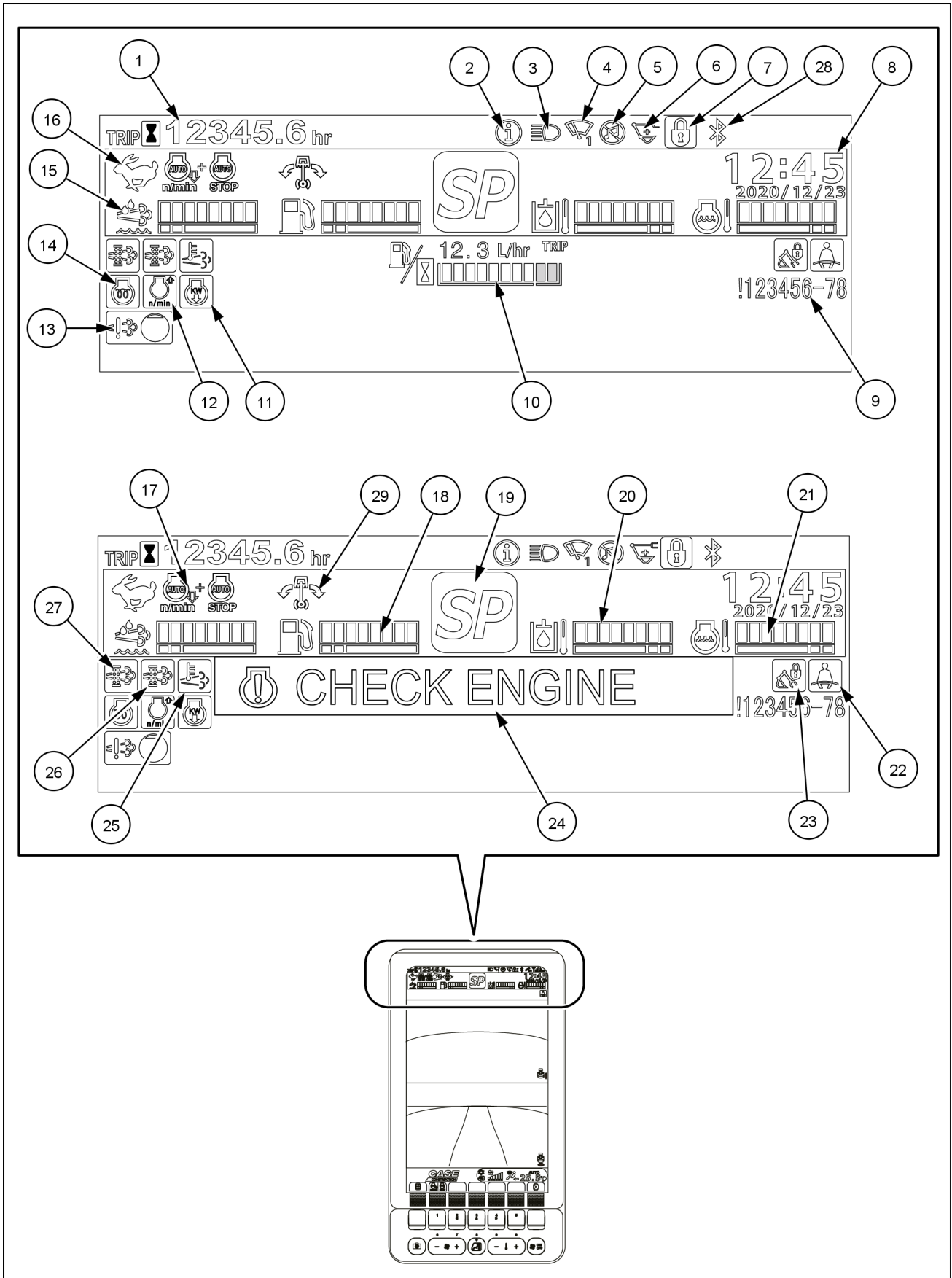

3 - CONTROLS AND INSTRUMENTS

1	Hour meter/trip meter
2	Notification
3	Working light
4	Front wiper
5	Radio mute
6	Auto pressure boost
7	Security function
8	Date and time
9	Diagnostic trouble code
10	Fuel consumption indicator/fuel economy gauge
11	Engine output low
12	Low idle speed increase
13	Hydrocarbon (HC) accumulation
14	Engine preheat
15	DEF/AdBLUE® level gauge
16	Travel mode
17	Idle mode
18	Fuel gauge
19	Work mode
20	Hydraulic oil temperature gauge
21	Engine coolant temperature gauge
22	Not wearing seat belt
23	Auto operation lever lock function
24	Message screen
25	Hot exhaust
26	Manual ATS cleaning
27	Automatic ATS cleaning
28	Bluetooth
29	Free swing

Camera display area/information display area

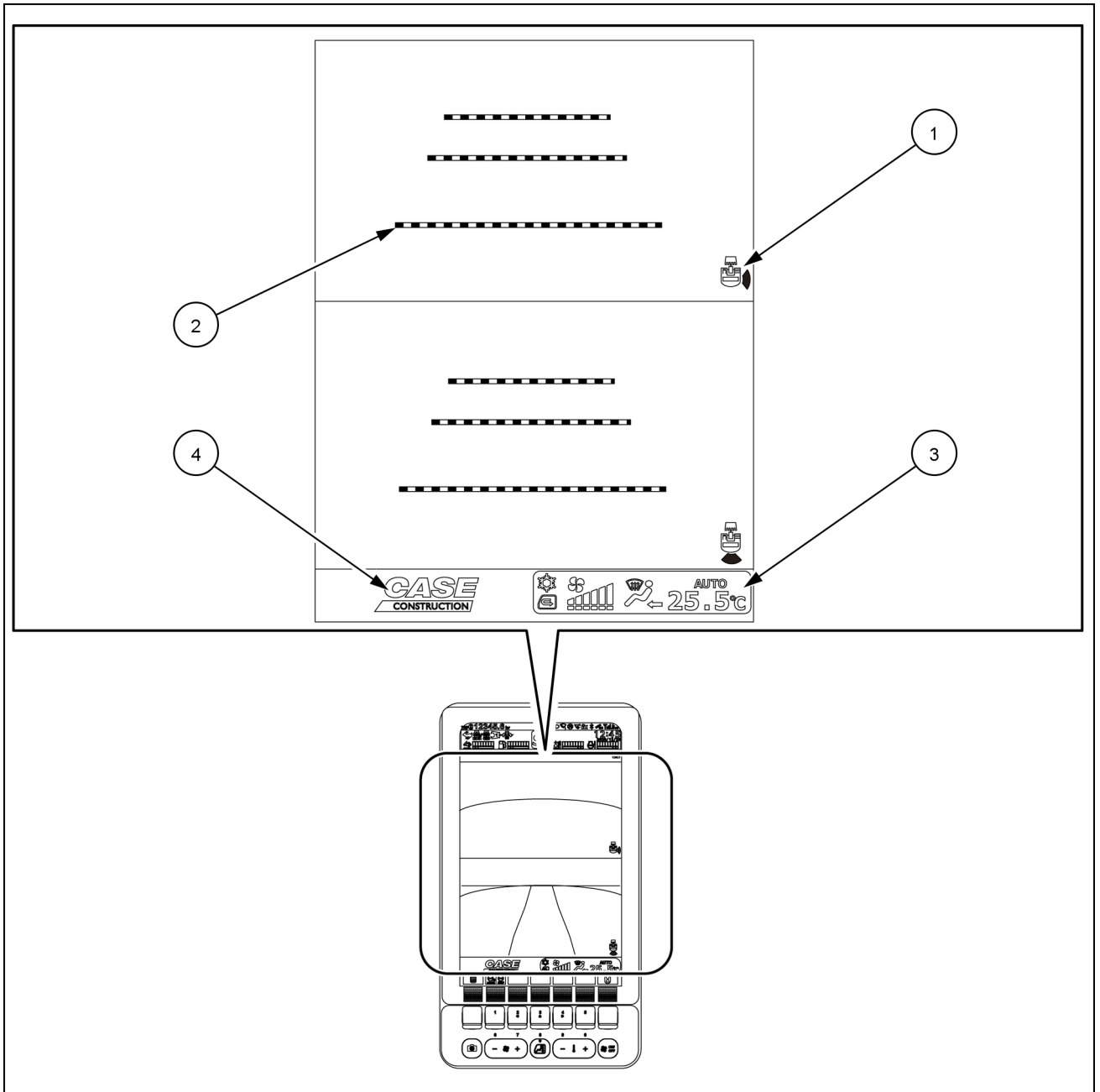

SML21CEX3494GA 7

1	Camera angle
2	Camera screen guide lines
3	Air conditioner information display
4	Brand logo/optional setting information

Explanation of icons

Work Modes:



Super Power: displayed when the mode that prioritizes machine output is selected.



Power: displayed when the high-load work mode is selected. Select from levels 1 - 10 for this mode. P1: Low speed - P10: High speed



Eco: displayed when the mode that prioritizes fuel economy is selected. Select from levels 1 - 10 for this mode. E1: Low speed - E10: High speed



Lifting: displayed when the mode that prioritizes lifting operability is selected. Select from levels 1 - 6 for this mode. L1: Low speed - L6: High speed This mode can be selected only for machines with HBCV. With machines without HBCV, if the switch is pressed, the message "LIFTING MODE NOT ACTIVE" is displayed and this mode cannot be selected.

Machine administrators can set a limitation so that the operator does not perform operations in an inappropriate work mode or a limitation on the maximum engine speed.

Each time the engine throttle switch on the right console is pressed, the mode switches between "P" and "E".

Turn the engine throttle switch to change the engine speed. When you turn the engine throttle switch in "P" mode to increase the engine speed to the maximum, the mode switches to "SP".

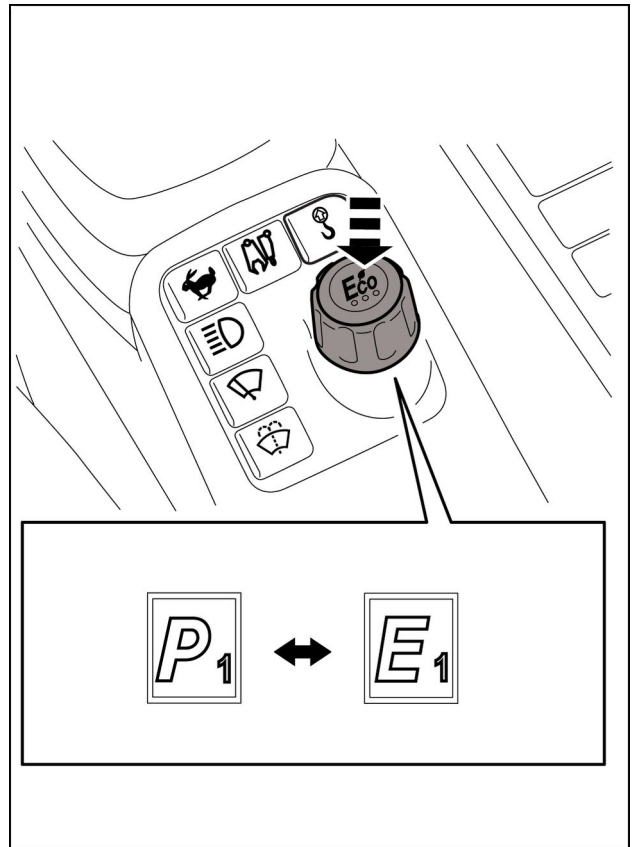

SMIL21CEX3495BA 8

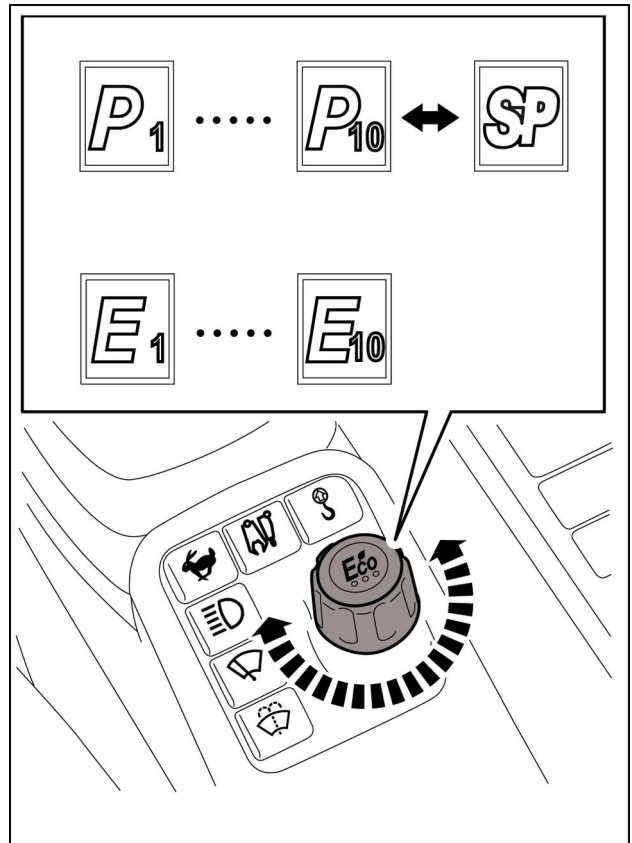

SMIL21CEX3496BA 9

Each time the lifting mode switch is pressed, the lifting mode turns ON or OFF.

The overload warning device operates when the lifting mode turns ON.

Turn the engine throttle switch to change the engine speed.

When the suspended load is excessive, the operator is notified by a warning message and alarm sound.

When performing lifting work, ensure that the machine is in lifting mode.

The lifting mode can be selected only for machines with HBCV.

With machines without HBCV, if the switch is pressed, the message "LIFTING MODE NOT ACTIVE" is displayed and the lifting mode cannot be selected.

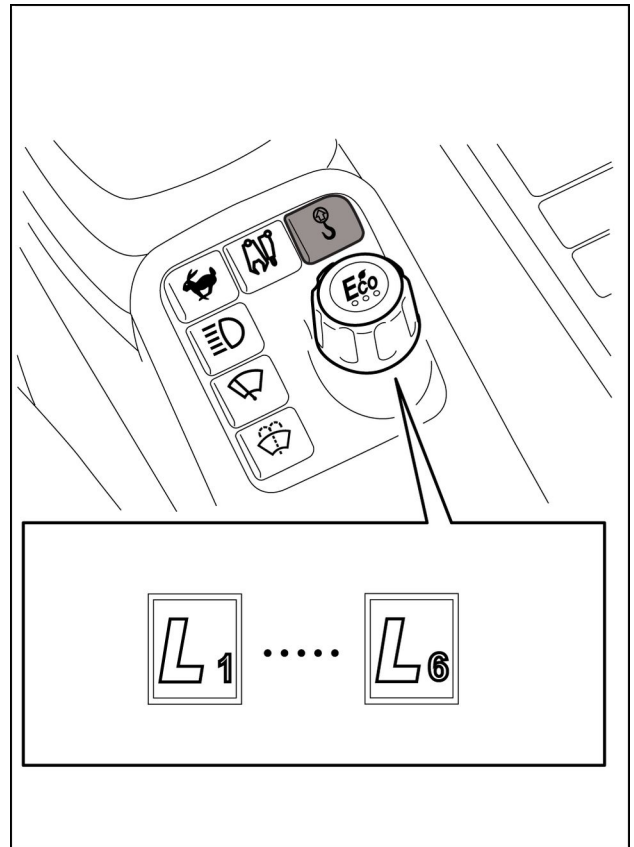

Travel mode

Each time the "Travel mode select switch" on the switch panel is pressed, the speed switches between low speed and high speed.



Displayed when the low-speed travel mode is selected.



Displayed when the high-speed travel mode is selected.

Low speed "Turtle": Use this mode when traveling on sloped, uneven, or soft ground.

High speed "Rabbit": Use this mode when traveling on hard, level, maintained ground.

NOTE: When the engine is started, low speed is selected automatically.

NOTE: When high speed is selected on the machine, if the load increases, for example when going uphill, the machine switches to low speed automatically and when the load drops, it returns to high speed automatically.

NOTE: Traveling direction may be shifted if the travel mode is changed while traveling. Stop traveling before switching the travel mode.

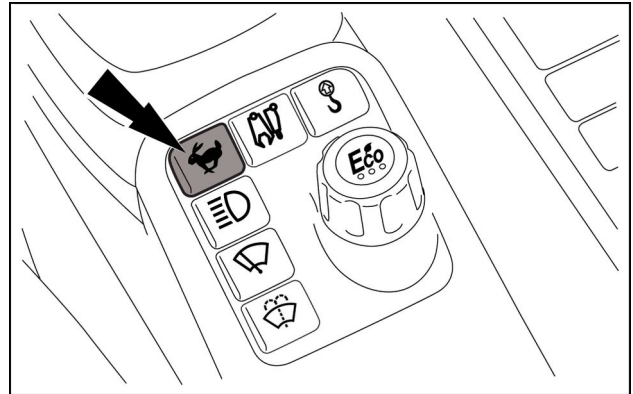

SMIL21CEX3498AA 11

Idle Mode

This indicates the selection status of auto idle and idle shutdown.



Displayed when auto idle is selected.



Displayed when auto idle and idle shutdown are selected.



Displayed when idle shutdown is selected.

The idle mode changes as follows each time the idle mode switch (function switch) is pressed. The image provided shows the factory settings.

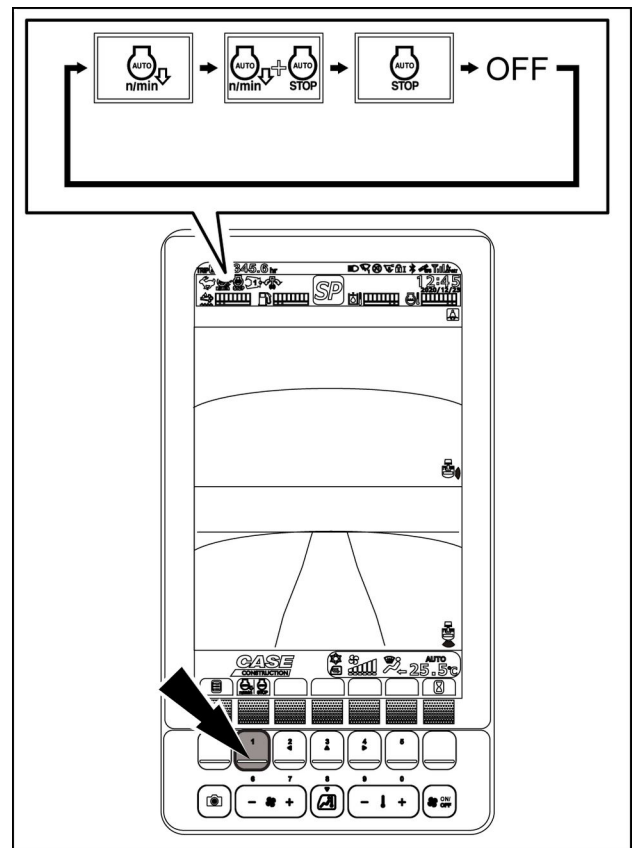

SMIL21CEX3500BA 12

Auto idle: changes the engine speed to idle when the machine has been left unoperated for **5 s**. To return to the engine speed required by the throttle, either operate the machine or turn the engine throttle volume.

Idle shut down: with the gate lock lever in the non-operation position (locked), if the engine speed is 1200 rpm or less and the throttle is not operated for **3 min**, the message "IDLE SHUT DOWN" is displayed on the screen and an alarm sounds, then the engine stops in **10 s**.

[Auto idle + idle shutdown] When this is selected, both the auto idle and idle shutdown modes are set. Changes the engine speed to idle when the machine has been left unoperated for **5 s**, then after another **3 min**, stops the engine. (The operation conditions are the same as the 2 items above.)

NOTE: To restart the engine after it has been stopped in an idle shutdown, first turn the starter switch key to "OFF", then start the engine.

NOTE: The idle mode settings can be changed on the "FUNCTION CONFIGURATION"

Engine coolant temperature gauge

The number of lit segments indicates the temperature of the engine coolant. The greater the number of lit segments, the higher the coolant temperature is.

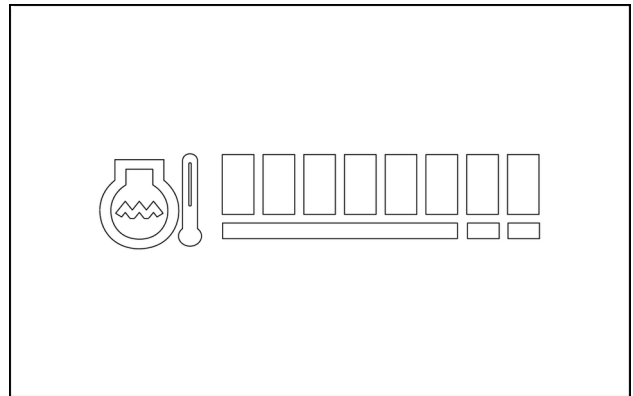

SMIL21CEX3601AA 13

If all segments are lit, an alarm sounds and the OVER HEAT message is displayed.

If the OVER HEAT message appears, lower the engine speed. If the temperature does not drop, stop the engine, remove the starter key, and call the CASE CONSTRUCTION dealer for machine inspection.

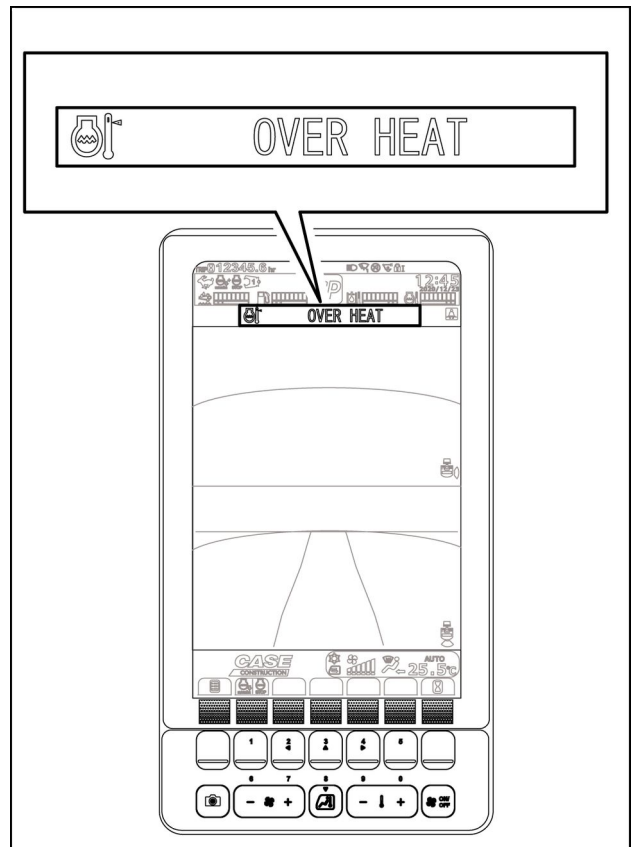

SMIL21CEX3602BA 14

Hydraulic oil temperature gauge

The number of lit segments indicates the temperature of the hydraulic oil. The greater the number of lit segments, the higher the hydraulic oil temperature is.

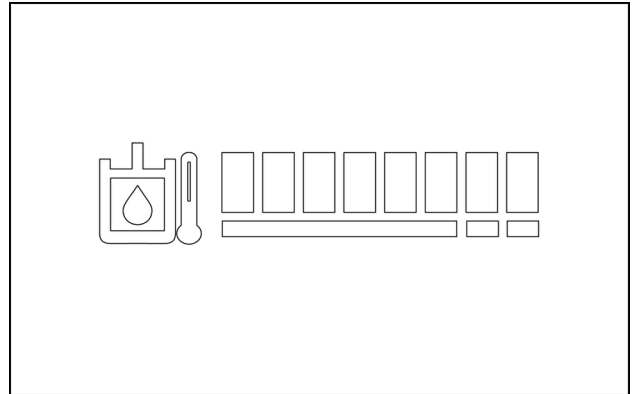

SMIL21CEX3603AA 15

If all segments are lit, an alarm sounds and the OVER HEAT message is displayed.

If the OVER HEAT message appears, lower the engine speed. If the temperature does not drop, stop the engine, remove the starter key, and call the CASE CONSTRUCTION dealer for machine inspection.

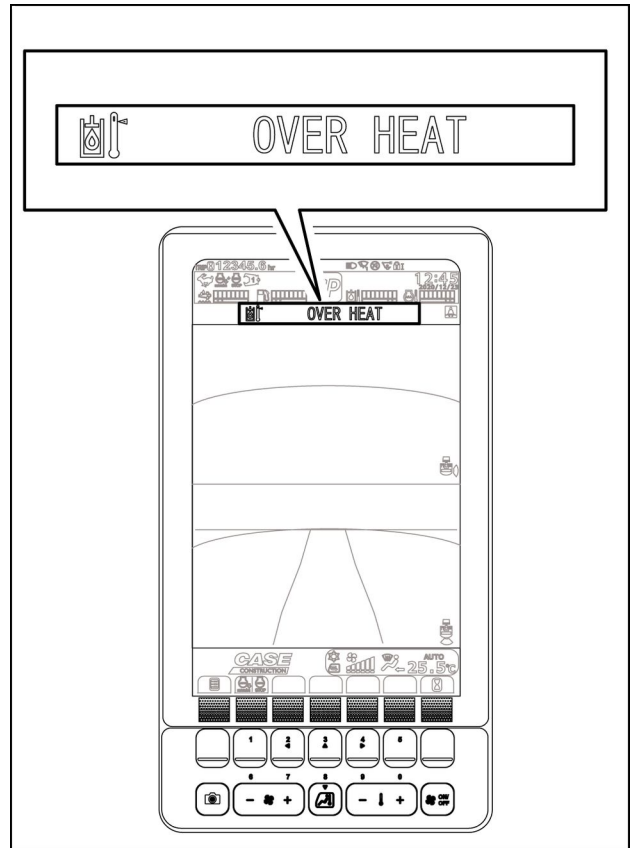

SMIL21CEX3604BA 16

Hour meter/trip meter

1. Hour meter: the hour meter displays the duration that the engine has operated in **0.1 h (6 min)** increments. The hour meter cannot be reset. The hourglass flashes while the engine is running.
2. Trip meter: the trip meter can be reset to "**0 h**" as desired. It displays the accumulated operating hours from the time of reset in **0.1 h (6 min)** increments.

If you press the hour meter switch **(3)** while the hour meter **(1)** is displayed, the display changes to the trip meter **(2)**. If the trip meter **(2)** is left as is, it switches back to the hour meter **(1)** after about **1 min**.

NOTE: Turning the starter switch key to the "OFF" position ends the hour meter **(1)** count. If the camera switch **(4)** is pressed after the key is turned to the "OFF" position, the hour meter **(1)** and clock are displayed for **30 s**.

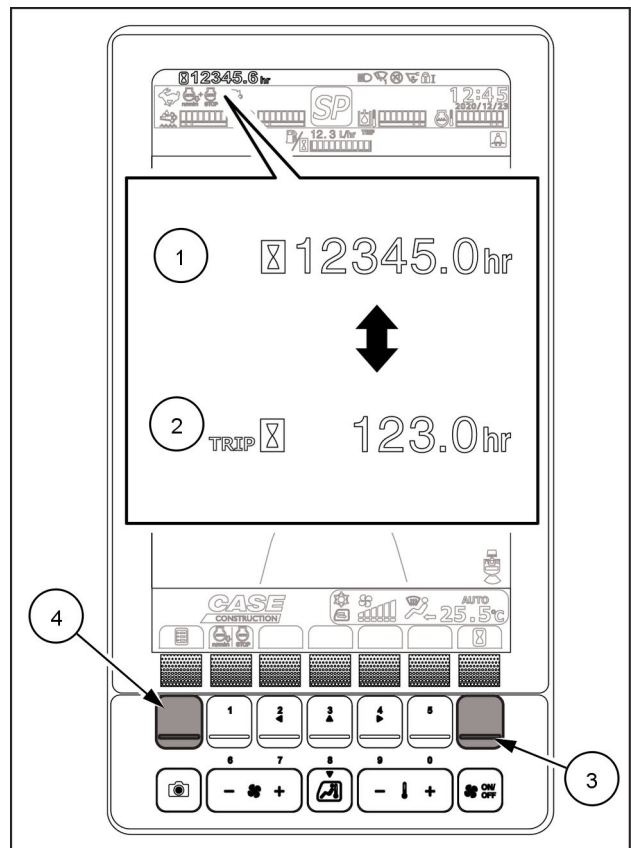

SMIL21CEX3605BA 17

Even when the key is turned to the OFF position, the hour meter **(1)** is displayed on the monitor for **30 s** if a cab door is opened. The hour meter disappears when the door is closed.

Press and hold the hour meter switch **(3)** while the trip meter **(2)** is displayed to reset the engine operating hours on the trip meter to "**0 h**".

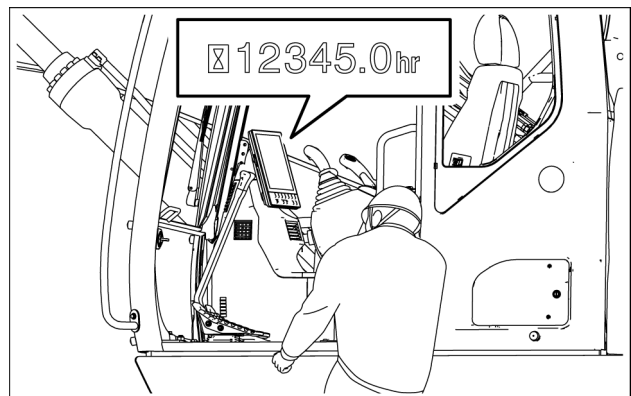

SMIL21CEX3606AA 18

Fuel gauge

The number of lit segments indicates the remaining level of fuel. If all segments are lit, the fuel tank is full.

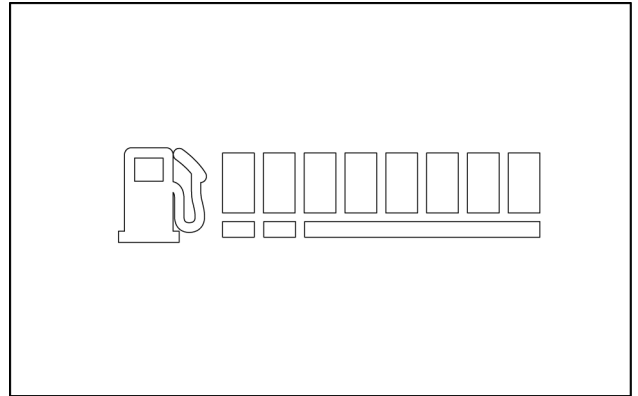

SMIL21CEX3607AA 19

If only one segment is lit, an alarm sounds and the LOW FUEL message is displayed.

If the LOW FUEL message appears, stop machine operation, stop the engine, and add fuel to the fuel tank.

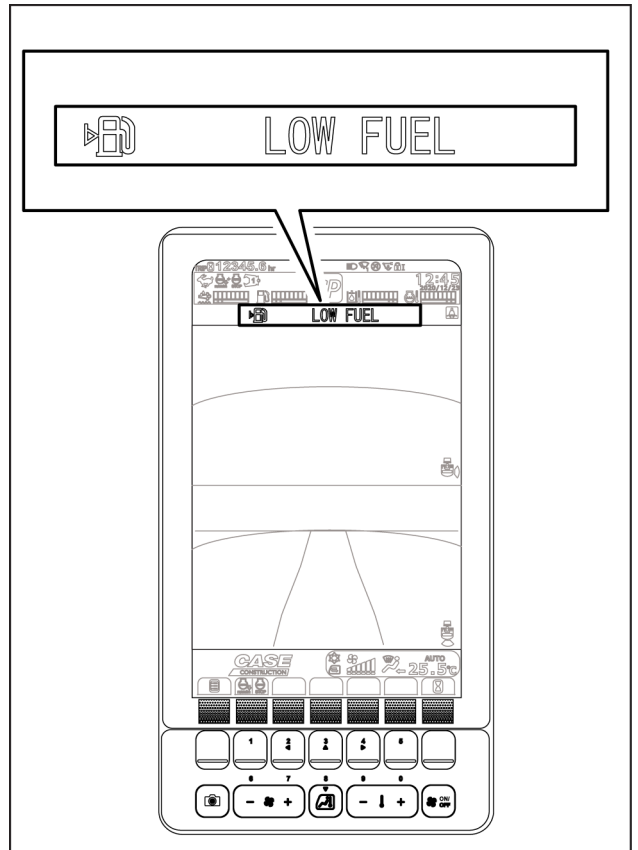

SMIL21CEX3608BA 20

Fuel consumption Indicator/Fuel economy gauge

1. Fuel consumption indicator: the display of the fuel consumption indicator (1) changes depending on the selection of the hour meter or trip meter (3). Normally, it displays the fuel consumption for the accumulated time. When the trip meter is selected, it displays the fuel consumption for the time displayed on the trip meter.
2. Fuel economy gauge: the gauge shows the energy saving operation status. When the operation status is energy saving, the number of indicators on the gauge (2) decreases. For high-load operation, the number of indicators on the gauge (2) increases.

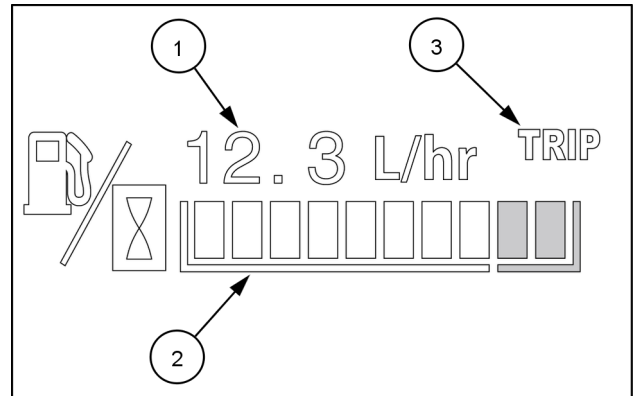

SMIL21CEX3609AA 21

1. Good fuel economy
2. Bad fuel economy

Even if the number of indicators on the gauge decreases, this does not cause a machine failure. However, as long as energy saving operations do not interfere with work, use energy saving operation to protect the environment. Also, referring to the fuel consumption helps achieve energy saving operation.

- Use P mode or E mode instead of SP mode.
- Do not move the lever too abruptly.
- Do not operate the machine or relieve the pressure with high loads.
- Use auto idle and one-touch idle.

Also, use idle shutdown to stop unnecessary idling.



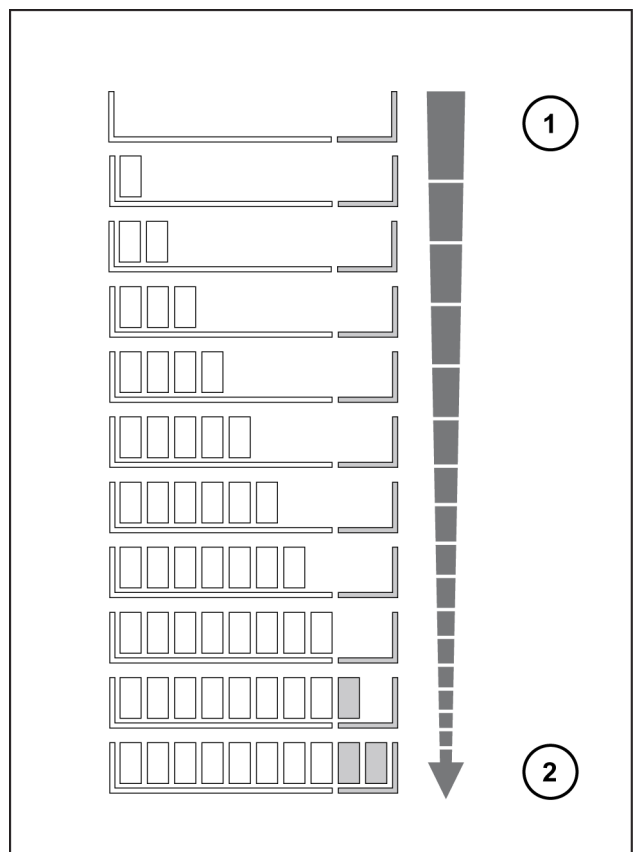

NOTE: Ask your local dealer or the certified service plant how to switch the fuel economy gauge display on and off.



SMIL21CEX3610BB 22

Camera angle display

The camera angle display shows the angle of the camera images displayed on the monitor.

- 
Indicates that the images from the rear view camera are displayed on the monitor.
- 
Indicates that the images from the side camera (right) are displayed on the monitor.
- 
Indicates that the images from the side camera (left) are displayed on the monitor. (If equipped)
- 
Displayed so that the operator can see if a position or angle of any of the cameras, which are facing 3 different directions, has shifted. (If equipped with Field View Monitor)
- 
Indicates that there is a problem in the monitor camera connections, such as short or disconnection.

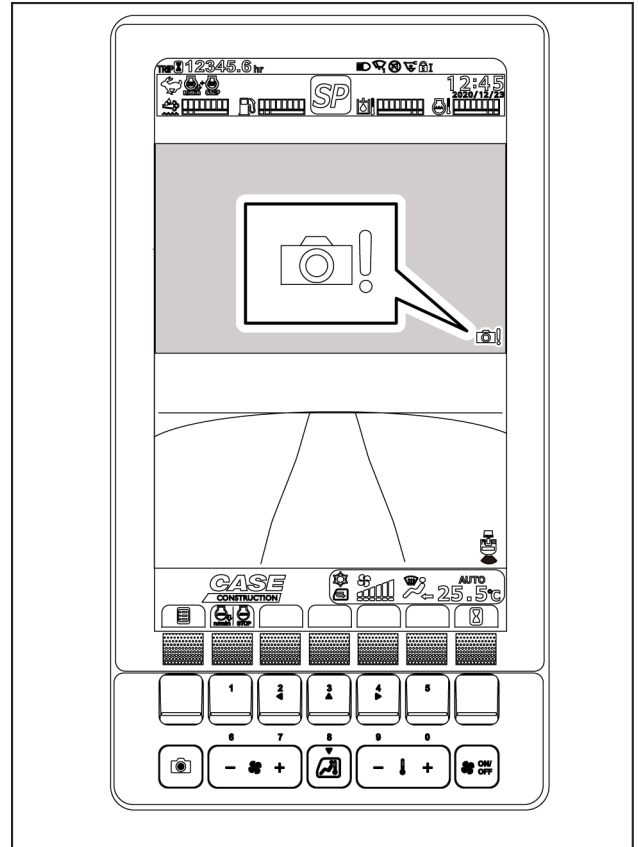

SMIL21CEX3612BA 23

On the monitor

Press the camera select button (1) on the monitor to change the camera image. (If equipped with FVM)

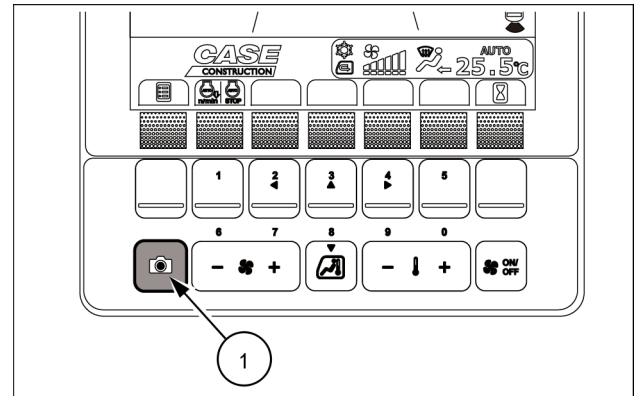

SMIL21CEX3613AA 24

On the left-hand control lever

Press the camera select switch (2) on the left-hand control lever to change the camera image. (If equipped with FVM)

NOTE: the function of the switch (2) can be customized (refer to "KNOB SWITCHES LAYOUT").

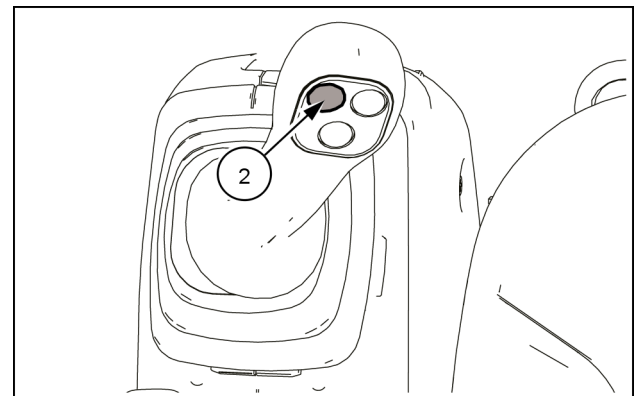

SMIL22CEX1986AA 25

(A) Rear view camera screen (lower) + right camera screen (upper)

(B) Rear view camera screen (lower left) + right camera screen (lower right) + FVM screen (upper) (if equipped)

(C) Rear view camera screen (lower) + right camera screen (upper right) + left camera screen (upper left) (if equipped)

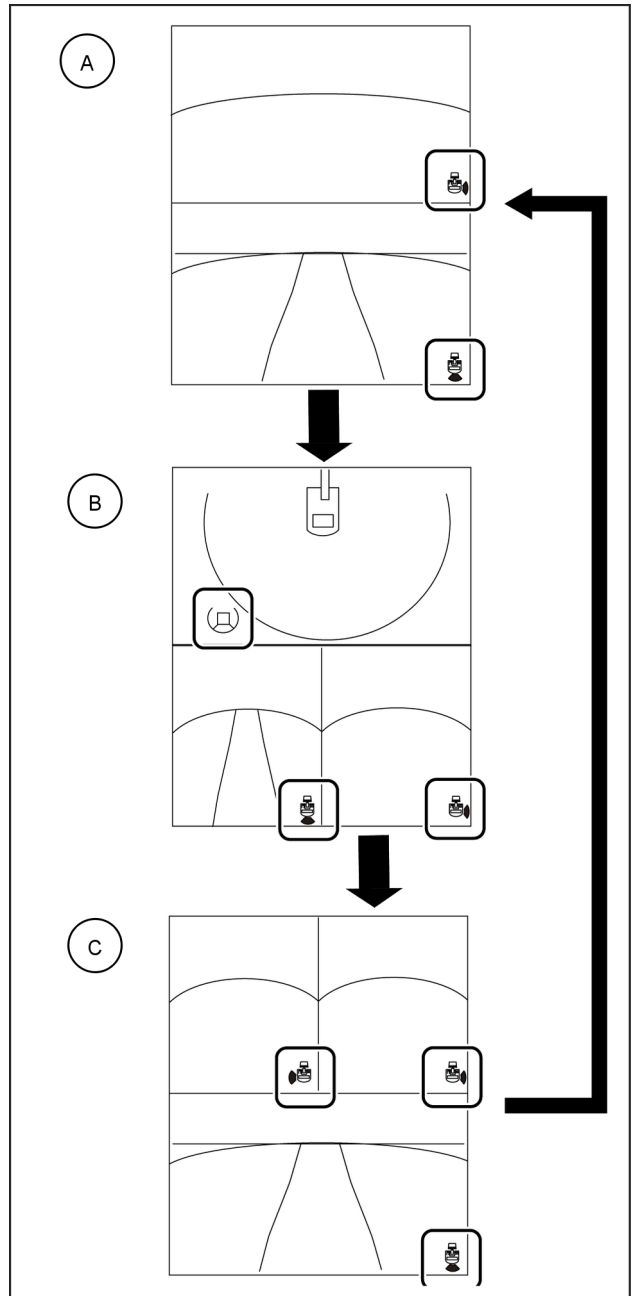

Working lights



Displayed when the working lights are ON.

Press the working light switch on the switch panel to turn the working light "ON" or "OFF". When you press the switch, the icon on the monitor display and the working light I up. When you press this switch again, they go out. When you turn the key to the "OFF" position with the working light ON, the light goes out in about **30 s**. The time until the light goes out can be changed in the settings.

When the key switch is turned "ON", the working light is "OFF".

When the working light is turned "ON", the monitor brightness is automatically adjusted.

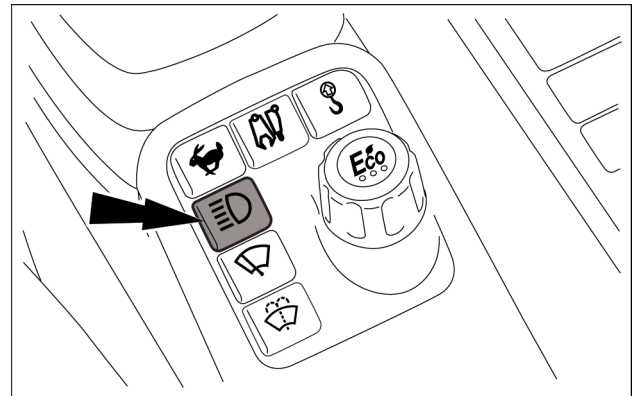

SMIL21CEX3615AA 27

Front wiper

This indicates the operation status of the front wiper.



Displayed when the wiper is operating intermittently.



Displayed when the wiper is operating continuously.

The operation status changes as follows each time the front wiper switch on the switch panel is pressed.

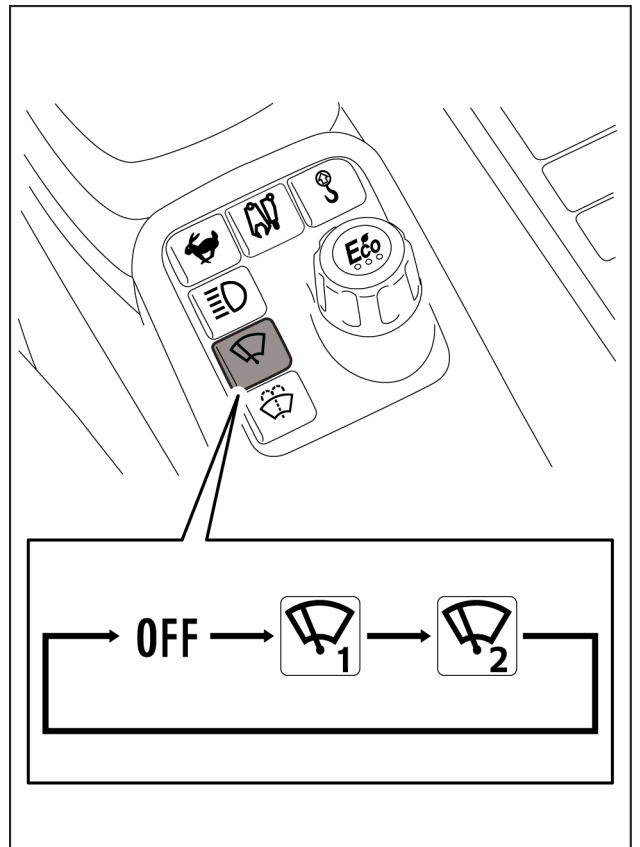

SMIL21CEX3616BA 28

If visibility is compromised by water droplets during operation, press the one-time wiper switch on the right operation lever to activate the wiper.

One time wiper is a function that moves the wiper blade back and forth while the switch is held down.

The wiper icon is not displayed on the monitor while one-time wiper is activated.

NOTICE: Do not operate the wipers when the windshield is dry. Doing so could cause cracks in wiper blades.

NOTICE: Working with mud or snow on the front wipers can damage them.

On the switch panel

Press and hold the windshield washer switch to activate the wiper and the washer to clean the windshield. Release the button to stop the cleaning operation.

NOTICE: Do not press the windshield washer switch and the windshield wiper switch at the same time. Also, do not turn the starter key to OFF position while holding down the windshield washer switch. Doing so could result in failures.

NOTICE: Do not operate the windshield washer if the reservoir tank is empty. This could break the electric pump.

On the right-hand control lever

Press and hold the windshield washer switch to activate the wiper and the washer to clean the windshield. Release the button to stop the cleaning operation.

NOTE: the function of the switch (2) can be customized (refer to "KNOB SWITCHES LAYOUT").

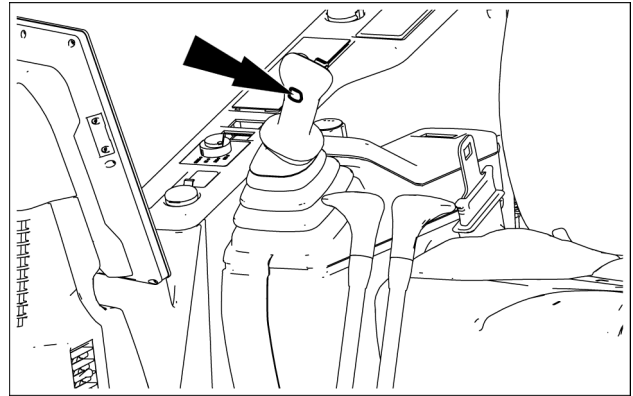

SMIL21CEX3617AA 29

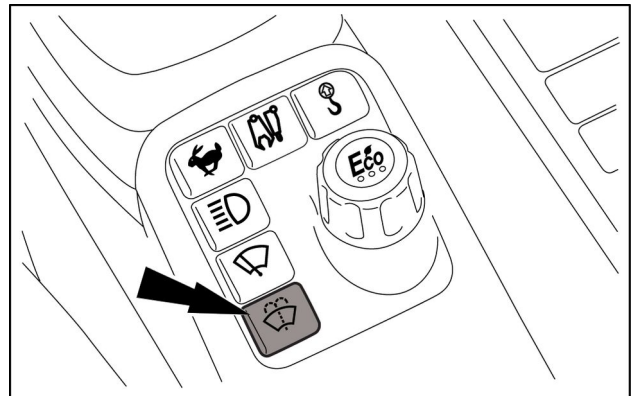

SMIL21CEX3618AA 30

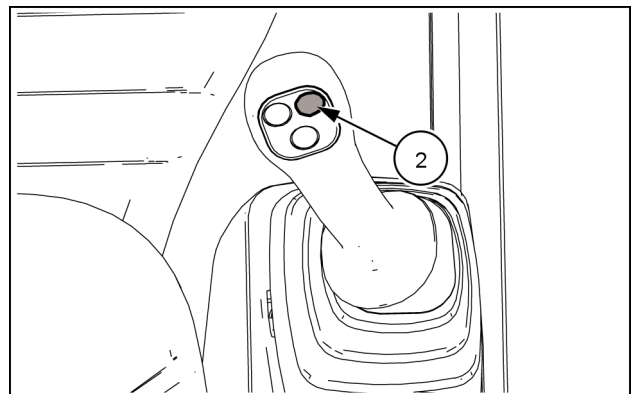

SMIL22CEX1991AA 31

Radio mute



Indicates that the radio volume is muted.

On the monitor

Press the radio mute control switch (function switch) to mute the radio volume.

The illustration provided shows the factory settings.

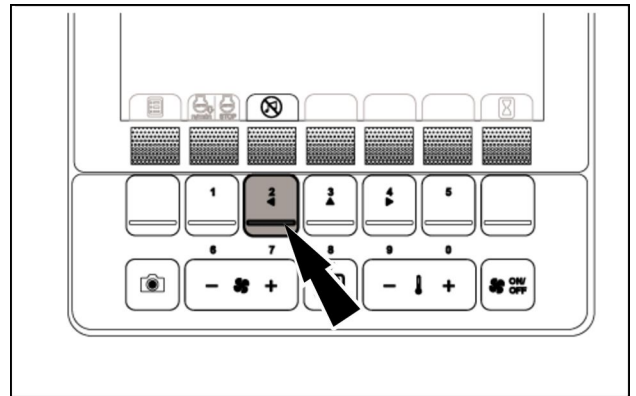

SMIL22CEX1241AA 32

On the left-hand control lever

Press the radio mute control switch to mute the radio volume.

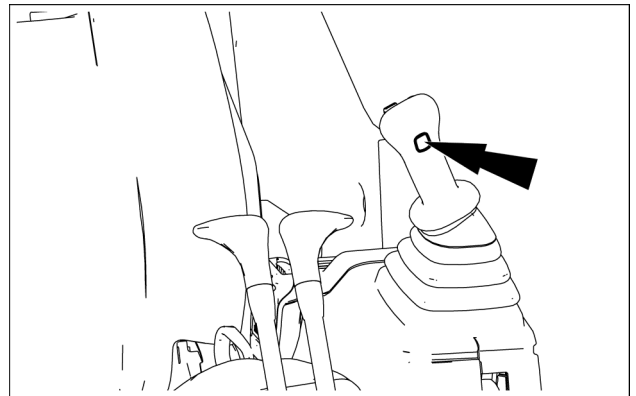

SMIL21CEX3619AA 33

Auto pressure boost



Indicates that the pressure in the hydraulic circuits is boosted.

To increase the digging force during attachment operations, hydraulic drive force is increased automatically to improve operability and work efficiency.

The icon stays lit while the auto pressure boost system is ON.

Seat belt



Lights up when the seat belt is not fastened.
Turns off after the seat belt is fastened.

If there is a problem in the system, the icon indicating a failure lights up.

If the icon lights up, consult your local dealer and the certified service plant.

1	"Seat belt alarm disabled" icon lights up
2	Diagnostic trouble code 7661
3	"ELEC. PROBLEM" lights up

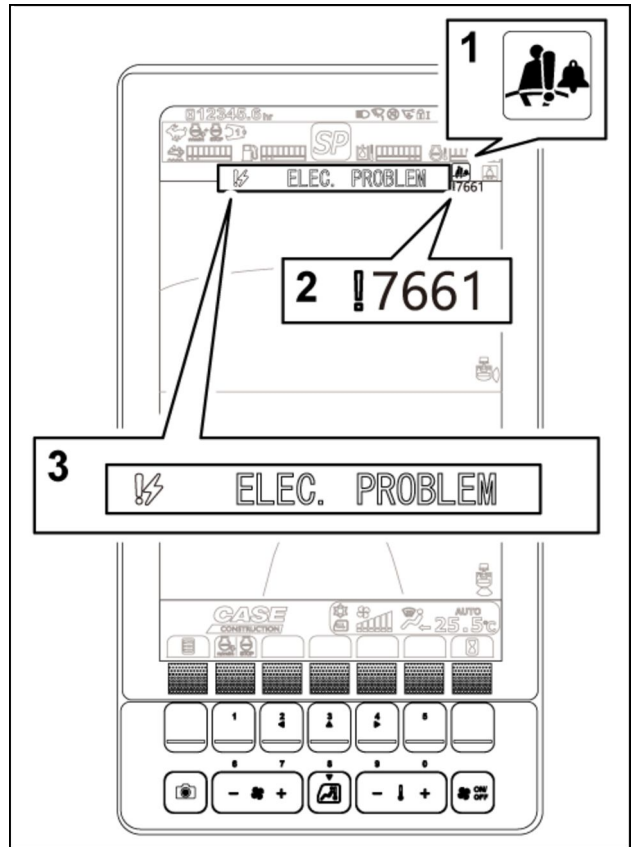

SMIL22CEX1242BA 34

Security device



Indicates that the security function is enabled.

The security function is available to prevent the machine from being stolen. If this function is enabled, you need to enter the security passcode to operate the machine. (Refer to chapter 4)

ATS cleaning

This indicates that ATS cleaning is underway or stopped.



Green: Displayed during automatic ATS cleaning.

Orange: Displayed during manual ATS cleaning.

Orange (flashing): Displayed when manual ATS cleaning can be performed.

Red (flashing): Displayed when manual ATS cleaning can be performed.



Green: Displayed when "AUTO ATS CLEANING STOP" is set to ON. "ATS Configuration"

Orange: Displayed when manual ATS cleaning cannot be operated or paused.

Orange (flashing): Displayed when manual ATS cleaning is required (when the gate lock lever is released).

Red: Displayed when manual ATS cleaning cannot be operated or paused.

Red (flashing): Displayed when manual ATS cleaning is required (when the gate lock lever is released).

Urea solution thawing and heat insulating

Device/engine preheating/cooling down/ high temperature exhaust gas

Urea solution thawing and heat insulating device



This icon is displayed when the urea solution is being thawed or kept warm.

ENG. PRE HEAT



This icon is displayed when the engine is preheating*.

* When using this machine in winter or when cold, turn the key switch to the "ON" position, and the engine preheat icon will be displayed and the engine will be preheated automatically. Wait for the icon to disappear, and then start the engine.

Cooling down



This icon is displayed when the cooling down of turbocharger is completed (even there is no problem if the engine is stopped). Check that this icon is displayed and then stop the engine.

High-temperature exhaust gas



Displayed during ATS CLEANING. When this icon is displayed, exhaust temperature is high.

These 4 icons are displayed when the respective functions have activated.

Auto operation lever lock function



Indicates that the auto operation lever lock function is activated.



Indicates that the auto operation lever lock function is limited. Contact your local dealer or the certified service plant.



Indicates that the auto operation lever lock function is disabled. Only a service engineer can configure the setting to disable this function. If this icon is displayed, contact your local dealer or the certified service plant.

Information notification



This indicates that there is information that the operator needs to know.

When there is information the operator needs to know, the information notification icon **(1)** is displayed. Press the applicable function switch **(2)** to display the NOTIFICATIONS screen **(3)**.

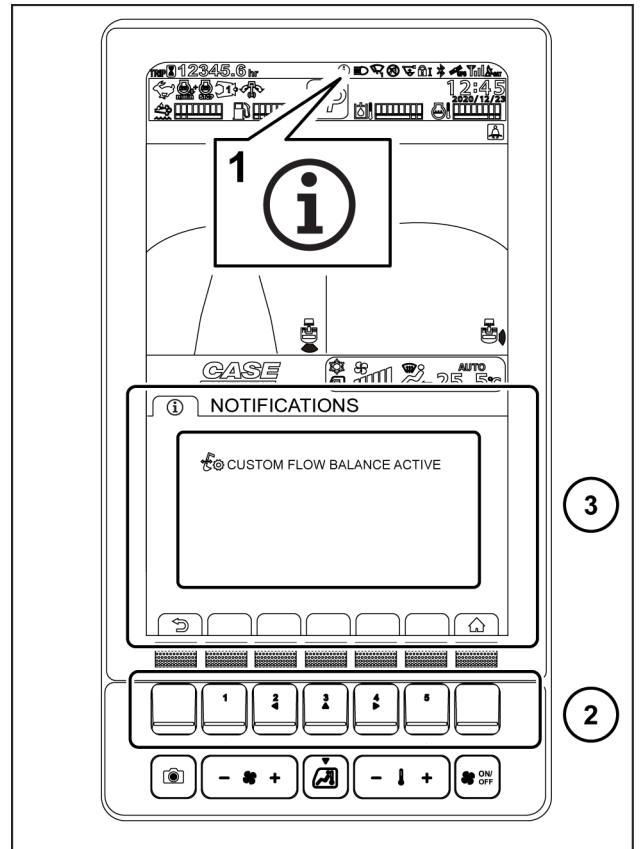

Hydrocarbon (HC) accumulation/low idle speed increase

Running the engine at low idle continuously causes hydrocarbons to accumulate. To burn the hydrocarbons, the engine speed needs to be increased. With this machine, the system detects the amount of hydrocarbon accumulation and increases the low idle speed to burn the hydrocarbons. Low idle speed increase



Displayed when the low idle speed increase function is activated.



Displayed when the low idle speed needs to be increased. (Displayed if the gate lock lever is in the center position (with the safety bar facing inside) when the function is activated.)

Hydrocarbon (HC) accumulation



Displayed when the amount of hydrocarbon accumulation increases. The low idle speed increase function is activated when this icon is displayed.

Free Swing



Indicates that the free swing function is activated.

Bluetooth



Displays when there is a Bluetooth connection.

When the mobile phone owned by operator is connected to a Bluetooth-enabled radio and make calls, the screen display will change depending on the call status.

(1) Standby mode / Outgoing / Incoming

(2) In a call

(3) Incoming number (Displays only on incoming)

- If there are other warning messages during an incoming call, incoming number is displayed alternating with the warning message.
- During a call or outgoing call, phone number you called is not displayed.
- Even if the radio volume is muted, it will be unmuted when it is not in standby mode (incoming, outgoing, or in a call). When the call ends and the phone returns to standby mode, the radio volume returns to the mute.
- Some calling apps, incoming call detection may not work or the phone number may not be displayed correctly.

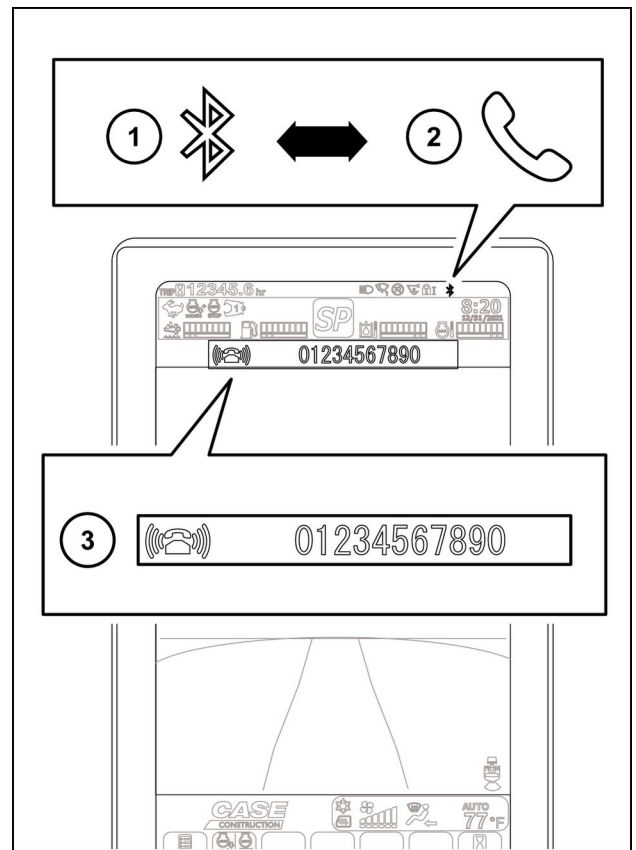

SMIL22CEX1967BA 36

Message icon descriptions

The message screen displays (1) information icons and (2) messages. Some message icons convey messages by itself and others convey messages by displaying multiple messages repeatedly. When there are multiple messages, they are displayed from the newest message to the oldest repeatedly. Some messages cause an alarm to sound when they are displayed. This section explains icons, messages, and actions to take.

NOTICE: The message area is color coded in red, orange, and green according to the emergency and importance levels.

Red	Warning	Warning for a failure or for a dangerous condition.
Orange	Caution	Caution for an operation.
Green	Check	Operation checks.

When a red or orange message area is displayed, take the following actions to solve the problem.





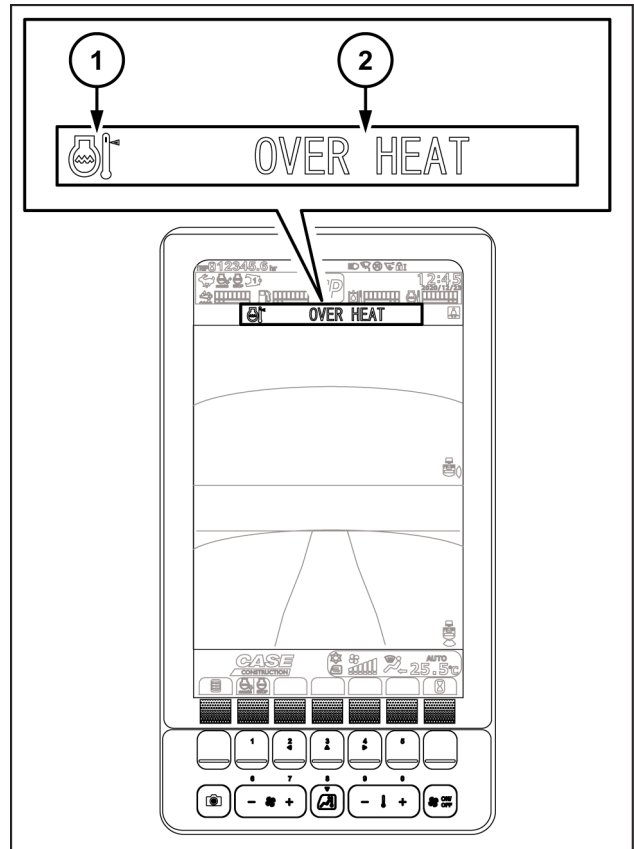









NOTE: If the message is still displayed after the actions are taken, consult the CASE CONSTRUCTION dealer or the certified service plant.

NOTE: The language of the messages can be changed. To change the message language, consult the CASE CONSTRUCTION dealer.

















SMIL21CEX3621BB 37



Messages with red background

Icon and text	Explanation	Action
 LOW OIL PRESSURE	LOW OIL PRESSURE: Indicates that the engine oil pressure is low. When this message is displayed, the engine stops automatically.	When the engine oil level is low, add the correct amount of engine oil. If the engine oil level is correct and oil is not leaking, there may be a hydraulic system failure. Stop the engine, and contact the CASE CONSTRUCTION dealer immediately.
 OVER HEAT ↕  POWER REDUCTION	OVER HEAT: The temperature of the engine coolant is too high.	Idle the engine to lower the coolant temperature. If the coolant level in the reservoir tank is too low, add more coolant. Check for coolant leaks. Stop the engine if coolant is leaking. If the message remains displayed, contact CASE CONSTRUCTION dealer immediately.
 OVER HEAT ↕  POWER REDUCTION	OVER HEAT: Indicates that the temperature of the air fed to the engine by the turbocharger is abnormally high.	Idle the engine and stop the operation to lower the turbocharger temperature. If the message remains displayed, contact the CASE CONSTRUCTION dealer immediately.
 OVER HEAT ↕  POWER REDUCTION	OVER HEAT: Indicates that the fuel temperature is too high. When this message is displayed and no action is taken, the engine runs at low idle automatically.	Stop the engine and check the fuel level in the fuel tank. If the fuel level is too low, add more fuel. If the message remains displayed after the fuel is added and the starter switch key is turned to the "ON" position, contact the CASE CONSTRUCTION dealer immediately.
 OVER HEAT ↕  POWER REDUCTION	OVER HEAT: Indicates that the engine oil temperature is too high.	Idle the engine to lower the engine oil temperature. If the message remains displayed, contact the CASE CONSTRUCTION dealer immediately.
 OVER HEAT ↕  POWER REDUCTION	OVER HEAT: Indicates that the hydraulic oil temperature is too high.	Idle the engine to lower the hydraulic oil temperature. If the message remains displayed, contact the CASE CONSTRUCTION dealer immediately.
 OVER HEAT ↕  POWER REDUCTION	OVER HEAT: Indicates that the temperature of the after-treatment device is too high.	Stop the engine and contact the CASE CONSTRUCTION dealer immediately.
 ALTERNATOR	ALTERNATOR: Indicates that there is a problem with the battery or the alternator.	Stop the engine and contact the CASE CONSTRUCTION dealer immediately.
 CHECK ENGINE	CHECK ENGINE: Indicates that there is a problem in the engine system, such as a short or disconnection.	Stop the engine and contact the CASE CONSTRUCTION dealer immediately.













3 - CONTROLS AND INSTRUMENTS

Icon and text	Explanation	Action
 ELEC. PROBLEM	ELEC. PROBLEM: Indicates that there is a problem in the electrical system.	Stop the engine and contact the CASE CONSTRUCTION dealer immediately.
 CHECK CAMERA	CHECK CAMERA: Indicates that there is a problem with the camera or camera wiring.	Contact the CASE CONSTRUCTION dealer immediately.
 LOW COOLANT	LOW COOLANT: Indicates that the coolant level is too low.	Idle the engine and refill the reservoir tank with coolant. Check for coolant leaks. Stop the engine if coolant is leaking. If the message remains displayed, contact the CASE CONSTRUCTION dealer immediately.
 AIR FILTER	AIR FILTER: Indicates that the air filter element is clogged. When this message is displayed and no action is taken, the engine can no longer deliver proper output.	Stop the engine and clean or replace the air filter element. If the message remains displayed, contact the CASE CONSTRUCTION dealer immediately.
 HYD. OIL FILTER	HYD.OIL FILTER: Indicates that the return filter in the hydraulic tank is clogged.	Stop the engine and check the return filter. If it is clogged, replace it. If the message remains displayed, contact the CASE CONSTRUCTION dealer immediately.
 REFILL DEF ↕  POWER REDUCTION	REFILL DEF: Indicates that the DEF/AdBLUE® level is too low.	Stop the engine and add DEF/AdBLUE® into the urea solution tank.
 CHECK ATS ↕  POWER REDUCTION	CHECK ATS: Indicates that there is an output restriction because the ATS has detected that the exhaust emission standards are not satisfied. (The engine torque is restricted and the engine can only run at idle.)	Stop the engine and contact the CASE CONSTRUCTION dealer immediately.
 CHECK DEF QUALITY ↕  POWER REDUCTION	CHECK DEF QUALITY: Indicates that there is an output restriction because the ATS has detected a quality abnormality of DEF/AdBLUE® (urea solution). (The engine torque is restricted and the engine can only run at idle.)	Stop the engine and replace the solution in the urea solution tank with DEF/AdBLUE® that satisfies quality requirements. "CHECK AdBlue QUALITY" Message (DEF/AdBLUE® does not satisfy quality requirements). If the message remains displayed, contact the CASE CONSTRUCTION dealer immediately.
 INCREASE ENGINE SPEED	INCREASE ENGINE SPEED: Indicates that hydrocarbons have accumulated.	Increase the low idle speed. If the message remains displayed, contact the CASE CONSTRUCTION dealer immediately.
 CHECK AIR CONDITIONER	CHECK AIR CONDITIONER: Indicates that the air conditioner is broken.	Contact the CASE CONSTRUCTION dealer immediately.
 SERVICE ATS	SERVICE ATS: This indicates that there is a problem in the ATS.	Stop the engine and contact the CASE CONSTRUCTION dealer immediately.















3 - CONTROLS AND INSTRUMENTS

Icon and text	Explanation	Action
 ENGINE OIL FILTER	ENGINE OIL FILTER: Indicates that the engine oil filter is clogged. When this message is displayed and no action is taken, the engine can no longer deliver proper output and in the worst case scenario, an engine failure may occur.	Stop the engine and replace the oil element. If the message remains displayed, contact the CASE CONSTRUCTION dealer immediately.
 STOP ENGINE	STOP ENGINE: Indicates that there is a problem in the engine system.	Stop the engine and contact the CASE CONSTRUCTION dealer immediately.





















Messages with orange and red background

Icon and text	Explanation	Action
 MANUAL ATS CLEANING REQUIRED   SET GATE LOCK LEVER TO CENTRAL POSITION	<p>MANUAL ATS CLEANING REQUIRED: Displayed when manual ATS cleaning is required during operation.</p>	<p>Set the gate lock lever to the center position (with the safety bar facing inside) and start ATS cleaning.</p>
 SERVICE ATS   MANUAL ATS CLEANING   DO NOT OPERATE	<p>SERVICE ATS: Indicates that a problem has occurred in the ATS during ATS cleaning.</p>	<p>When the text message "DO NOT OPERATE" disappears, stop the engine and contact the CASE CONSTRUCTION dealer immediately.</p>
 SERVICE ATS   MANUAL ATS CLEANING CANCELED   DO NOT OPERATE	<p>SERVICE ATS: Indicates that a problem has occurred in the ATS and ATS cleaning is stopped.</p>	<p>When the text message "DO NOT OPERATE" disappears, stop the engine and contact the CASE CONSTRUCTION dealer immediately.</p>







Messages with orange background

Icon and text	Explanation	Action
 ENGINE STOP	ENGINE STOP: Indicates that the emergency stop switch on the lower left of the seat was pressed and the emergency engine stop function is activated.	The engine cannot be started with the switch held down. Check your surroundings carefully and release the emergency stop switch, then start the engine.
 IMPROPER SHUT DOWN	IMPROPER SHUT DOWN: Displayed if the engine is stopped when the engine needs to be cooled down.	Start the engine again and run it at low idle at least for 5 min.
 FAN IS REVERSED	FAN IS REVERSED: Indicates that the hydraulic fan is in reverse mode. (If equipped)	
 OVER LOAD	OVER LOAD: Indicates that the suspended load exceeds the permitted limit.	The machine can fall over. Reduce the suspended load or change the attachment position to prevent the machine from falling over.
 LOW FUEL	LOW FUEL: Indicates that the fuel in the fuel tank is too low.	Stop the engine and refill the fuel tank.
 AUXILIARY SET-UP REQUIRED	AUXILIARY SET-UP REQUIRED: Displayed when a crusher or breaker operation is performed without selecting the corresponding mode.	Check the type of the end attachment in use and select the correct option line mode.
 SERVICE DUE	SERVICE DUE: Displayed when the time for replacing the periodic replacement parts has been reached. (These parts are displayed on the TIME UNTIL REPLACEMENT screen.)	Replace the periodic replacement parts in a timely manner.
 IDLE SHUT DOWN	IDLE SHUT DOWN: Displayed just before the engine is stopped automatically with the idle shutdown selected.	
 CHECK CALIBRATION	CHECK CALIBRATION: A message for service engineers.	Stop the engine and contact the CASE CONSTRUCTION dealer immediately.
 REFILL DEF	REFILL DEF: Indicates that the DEF/AdBLUE® level is too low.	Stop the engine and add DEF/AdBLUE® into the urea solution tank.
 REFILL DEF ↕  POWER REDUCTION	REFILL DEF: Indicates that there is an output restriction due to a low DEF/AdBLUE® level.	Stop the engine and add DEF/AdBLUE® into the urea solution tank
 CHECK ATS ↕  POWER REDUCTION	CHECK ATS: Indicates that there is an output restriction because the ATS has detected that the exhaust emission standards are not satisfied.	Stop the engine and contact the CASE CONSTRUCTION dealer immediately.

3 - CONTROLS AND INSTRUMENTS

Icon and text	Explanation	Action
 CHECK ATS   POWER REDUCTION	CHECK ATS: Indicates that there is an output restriction because the ATS has detected that the exhaust emission standards are not satisfied.	Stop the engine and contact the CASE CONSTRUCTION dealer immediately.
 CHECK DEF QUALITY	CHECK DEF QUALITY: Indicates that the ATS has detected a quality abnormality of DEF/AdBLUE® (urea solution).	Stop the engine and replace the solution in the urea solution tank with DEF/AdBLUE® that satisfies quality requirements. If the message remains displayed, contact the CASE CONSTRUCTION dealer immediately.
 CHECK DEF QUALITY   POWER REDUCTION	CHECK DEF QUALITY: Indicates that there is an output restriction because the ATS has detected a quality abnormality of DEF/AdBLUE® (urea solution).	Stop the engine and replace the solution in the urea solution tank with DEF/AdBLUE® that satisfies quality requirements. If the message remains displayed, contact the CASE CONSTRUCTION dealer immediately.
 DRAIN WATER IN FUEL FILTER	DRAIN WATER IN FUEL FILTER: Indicates that there is water accumulation in the fuel prefilter.	Drain water out of the fuel prefilter.
 MANUAL ATS CLEANING   DO NOT OPERATE	MANUAL ATS CLEANING: This message is displayed during manual ATS cleaning. Stop the machine operation. (If cleaning is started after ATS cleaning is requested, an alarm sounds for about 2 s)	
 INCREASE ENGINE SPEED	INCREASE ENGINE SPEED: Indicates that hydrocarbons have accumulated.	Increase the low idle speed. If the message remains displayed, contact the CASE CONSTRUCTION dealer immediately.
 MANUAL ATS CLEANING REQUIRED   SET GATE LOCK LEVER TO CENTRAL POSITION	MANUAL ATS CLEANING REQUIRED: Displayed when manual ATS cleaning is required during operation.	Set the gate lock lever to the center position (with the safety bar facing inside) and start ATS cleaning.
 PUSH ATS SWITCH TO ACTIVATE	PUSH ATS SWITCH TO ACTIVATE: Displayed when automatic/ manual ATS cleaning is stopped or when manual cleaning is requested.	Press the ATS switch and resume the ATS cleaning.
 MANUAL ATS CLEANING CANCELED   DO NOT OPERATE	MANUAL ATS CLEANING CANCELED: Indicates that a problem has occurred in the ATS and ATS cleaning is stopped. (An error code that determines the cause of the problem may be displayed.)	Stop the engine and contact the CASE CONSTRUCTION dealer immediately. (If an error code is displayed, write it down.)
 AUTO LEVER LOCK ACTIVE	AUTO LEVER LOCK ACTIVE: Indicates that the auto lever lock function is enabled.	For details, refer to "Auto Operation Lever Lock

Messages with green background

 AUTO WARM UP	AUTO WARM UP: Indicates that auto warm-up is underway.	
 AUTO ATS CLEANING REQUIRED	AUTO ATS CLEANING REQUIRED: Displayed when automatic ATS cleaning is stopped or when automatic ATS cleaning is requested.	
 THROTTLE LIMITATION ACTIVE	THROTTLE LIMITATION ACTIVE: Indicates that throttle restrictions are activated.	
 LIFTING MODE NOT ACTIVE	LIFTING MODE NOT ACTIVE: Indicates that the lifting mode cannot be selected.	
 WORK MODE LIMITATION ACTIVE	WORK MODE LIMITATION ACTIVE: Indicates that the WORK MODE LIMITATION setting is enabled (work mode restrictions are activated).	
 01234567890	Displays the phone number when you receive an incoming call. (Some calling apps may not display the phone number correctly.)	

DEF/AdBLUE® level gauge

The number of segments lit up indicates the amount of **DEF/AdBLUE®** remaining. When all the segments are lit up, the urea solution tank is full. The segments light up as shown below according to the remaining amount.

DEF/AdBLUE® level	10% or more	Less than 10%	Less than 5%	0%
Color	White	Orange	Orange (flashing)	Red
Segments	8 - 2	1	1	0

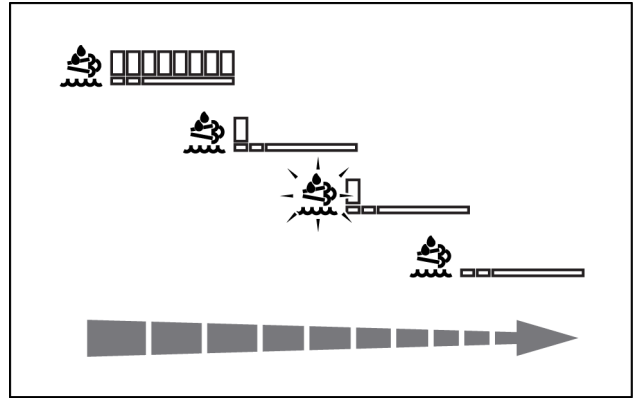

SML21CEX3622AA 38

Monitor the level and add **DEF/AdBLUE®** in advance, before the **DEF/AdBLUE®** level becomes lower than **10%**.

We recommend adding **DEF/AdBLUE®** at the same time when adding fuel. For details on the engine output restriction due to the low **DEF/AdBLUE®** level contact the CASE CONSTRUCTION dealer.

Inducement icon



This icon indicates that restriction is applied on the engine output.

If this icon is displayed, refill **DEF/AdBLUE®**. If the icon persists after refilling **DEF/AdBLUE®**, contact our dealer or authorized service shop.

User information mode



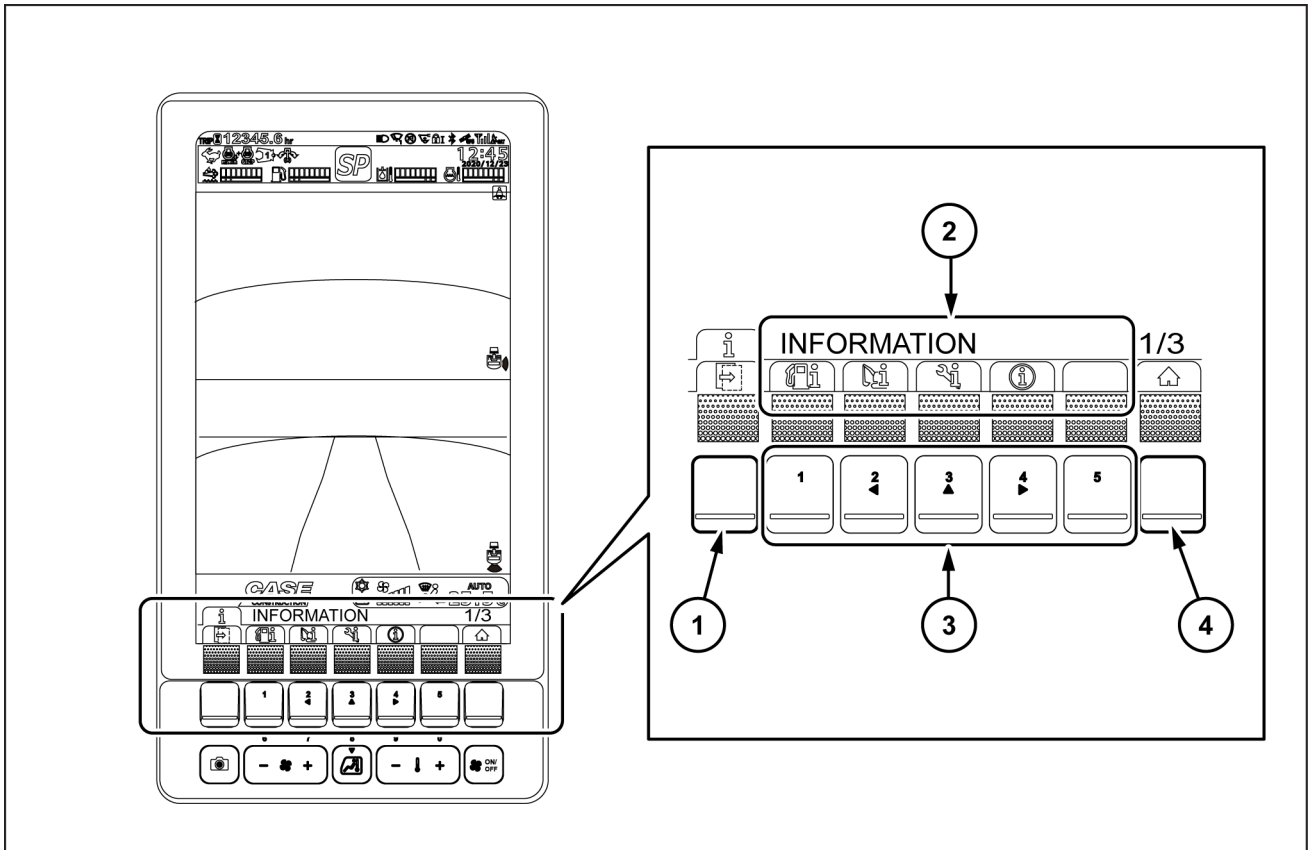









In user information mode, the following information can be viewed and display settings can be configured.



SMIL21CEX3625FB 39

Press the function switch **(1)** to navigate between pages. Information icons are displayed on the function switch tab **(2)**. Press the corresponding function switch **(3)** to move to the selected information page. Use the function switch **(4)** to return to the normal screen. The following items can be viewed.

3 - CONTROLS AND INSTRUMENTS

Icon	Icon name	Description
	FUEL CONSUMPTION	Enables you to view the fuel economy for the past 7 days.
	MACHINE INFORMATION	Enables you to view the vehicle status in detail.
	TIME UNTIL REPLACEMENT	Enables you to view the information on the time for replacing the periodic replacement parts.
	NOTIFICATIONS	Enables you to view the information that the operator needs to know.
	DISPLAY CONFIGURATION	Enables you to configure the screen brightness, camera, and date/time settings.
	AUXILIARY HYDRAULICS (refer to chapter 9)	Enables you to switch between Breaker and Crusher, manage operations according to the model, and set the pressure and flow rate.
	ATS CONFIGURATION	Enables you to view and change the ATS configuration.
	FUNCTION CONFIGURATION	Enables you to configure settings for functions related to energy-saving and safety.
	CUSTOM FLOW BALANCE	Enables you to adjust the operation balance according to the end attachment to be used.
	MONITOR SWITCHES LAYOUT	Enables you to create shortcuts for frequently used menu screen items on the function switch tab in the normal display mode.
	KNOB SWITCHES LAYOUT	Enables you to change the switch function of the control levers switches.
	PASSCODE SETTING	Enables you to change the passcode.
	FACTORY SETTING	The settings on the menu screen can be reset to the factory settings all at once.

FUEL CONSUMPTION



The fuel economy for the past 7 days can be viewed.

The average fuel economy for the past 7 days can be viewed by date with a simple graph in (1). If you select a date in (1), detailed information on the fuel consumption, operation hours, and average fuel economy of the date selected in (2) can be viewed in numeric values.

Descriptions of icons on the FUEL CONSUMPTION screen.

NOTE: When the unit is changed on the DISPLAY CONFIGURATION screen, the value is displayed in the specified unit and the date is displayed in the specified format.



Year/month/day of cursor specified date is displayed.



Fuel consumption of cursor specified date is displayed.



Operating hour of cursor specified date is displayed.



Fuel cost (fuel consumption / operating hour) of cursor specified date is displayed.

Operation explanation for function switches

Press (1) to return to the menu selection screen. (If the function switch on the normal screen was used to open the FUEL CONSUMPTION screen, the screen returns to the normal screen.) Press (2) to return to the normal screen. Press (3) to move the cursor to the left or right to select the date.

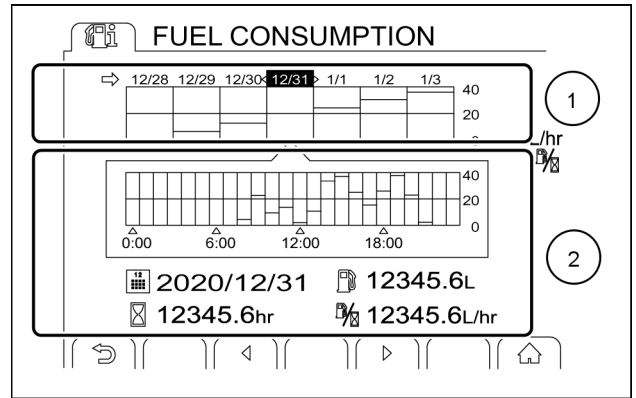

SMIL21CEX3118AA 40

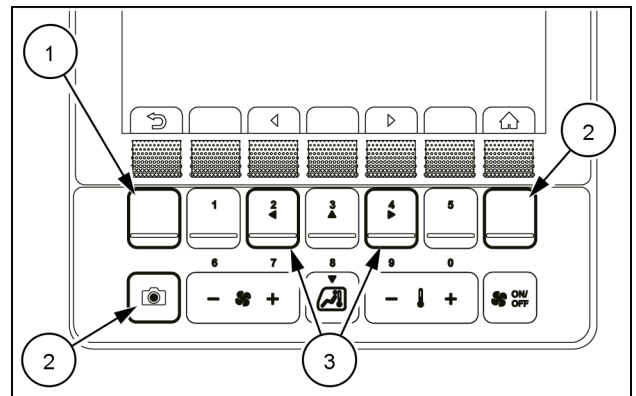

SMIL21CEX3120AA-01 41

MACHINE INFORMATION



Detailed machine conditions can be checked.

The items displayed on page 1 show various machine information. View this page when you need to tell a service engineer the machine condition.

- **ENGINE SPEED (min-1)**
Shows the engine speed.
- **P1 PRESS. (MPa, psi, kgf/cm2)**
Shows the pump P1 pressure value.
- **P2 PRESS. (MPa, psi, kgf/cm2)**
Shows the pump P2 pressure value.
- **2ND AUX. PRESS. (MPa, psi, kgf/cm2)**
Shows the 2nd option pump pressure value.
This is displayed only when "2nd option" is selected in the settings. Contact the CASE CONSTRUCTION dealer or the certified service plant to set "2nd option".
- **COOLANT TEMP. (°C/°F)**
Shows the coolant temperature.
- **HYD. OIL TEMP. (°C/°F)**
Shows the hydraulic oil temperature.
- **BATTERY VOLT. (V)**
Shows the battery voltage.

The items displayed on page 2 show the information related to the engine.

- **REMAINING TIME OF COOL DOWN (sec)**
Shows the time remaining until the turbocharger cools down.
- **OUTPUT REDUCTION (ON/OFF)**
Shows the status of output restriction.
- **BAROMETRIC PRESS. (kPa, psi, kgf/cm2)**
Shows the barometric pressure value.

The items displayed on page 3 show the fuel economy of the machine.

- **ACCUM. FUEL CONSUMPTION (L/gal)** Shows the cumulative fuel consumption.

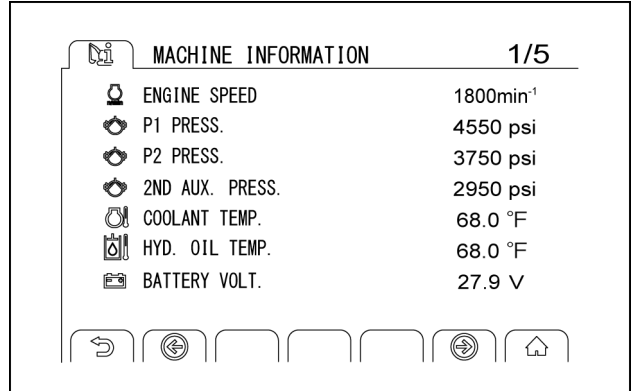

SMIL22CEX1987AA 42

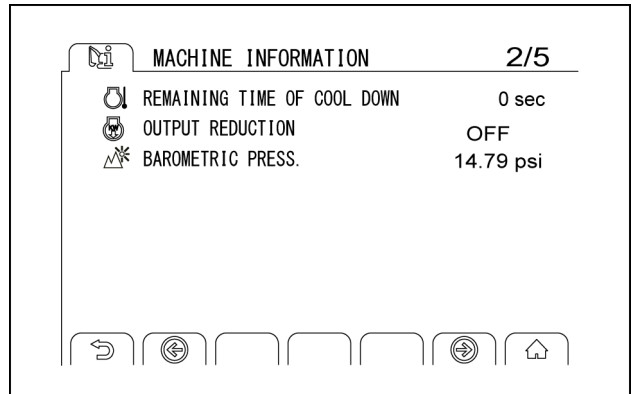

SMIL22CEX1988AA 43

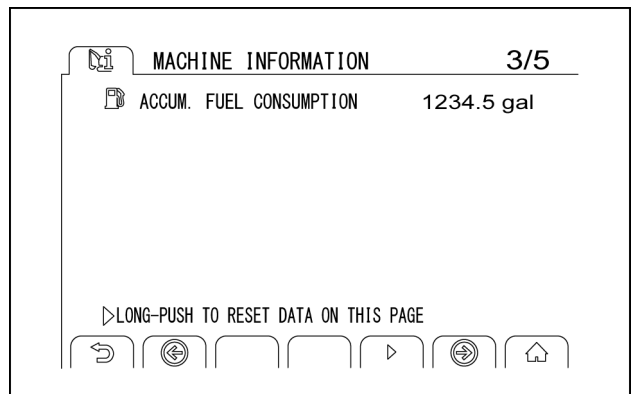

SMIL22CEX1989AA 44

Press and hold the right function switch for **3 s**.

An alarm sounds and the information on this page is reset all at once.

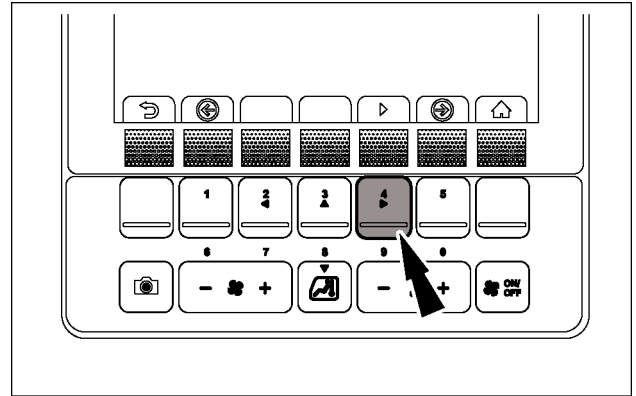

SMIL21CEX3257AA 45

The items displayed on page 4 show the machine usage log.

- **ENGINE OPERATION TIME (hr)**
Shows the engine hours.
- **MACHINE OPERATION TIME (hr)**
Shows the machine operating hours.
- **SWING OPERATION TIME (hr)**
Shows the swing operation hours.
- **TRAVEL OPERATION TIME (hr)**
Shows the travel operation hours.
- **ONE WAY OPERATION TIME (hr)**
Shows the hours the machine was operated in ONE WAY mode.
- **TWO WAY OPERATION TIME (hr)**
Shows the hours the machine was operated in TWO WAY mode.

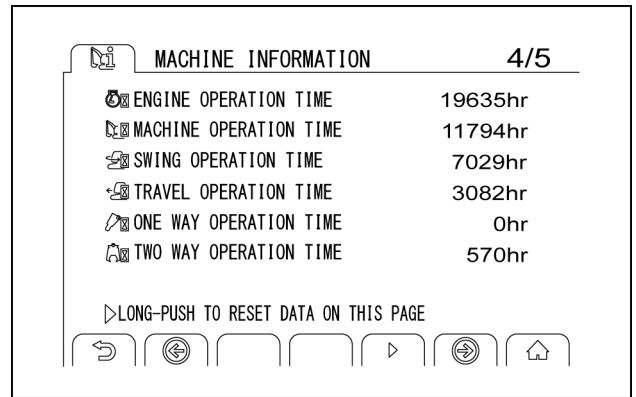

SMIL22CEX1990AA 46

Press and hold the right function switch for **3 s**. An alarm sounds and the information on this page is reset all at once.

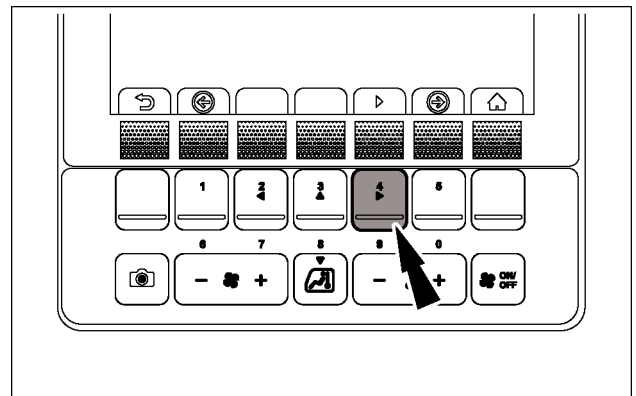

SMIL21CEX3259AA 47

The items displayed on page 5 show the name of the Bluetooth-connected device.

RADIO DEVICE NAME: Shows the identification name of the Bluetooth module in the radio unit.

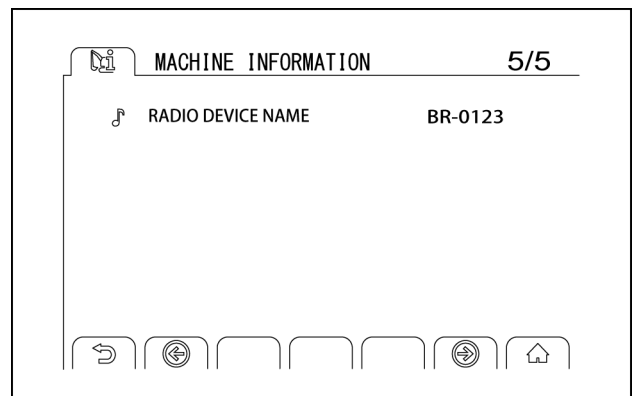

SMIL22CEX1992AA 48

Operation explanation for function switches

Press **(1)** to return to the menu selection screen. (If the function switch on the normal screen was used to open the MACHINE INFORMATION screen, the screen returns to the normal screen.)

Press **(2)** to return to the normal screen. Press **(3)** to go forward or back 1 page.

Press and hold **(4)** for **3 s** to reset the information on the page all at once.

NOTE: When the screen lock is ON, the information on the page cannot be reset all at once.

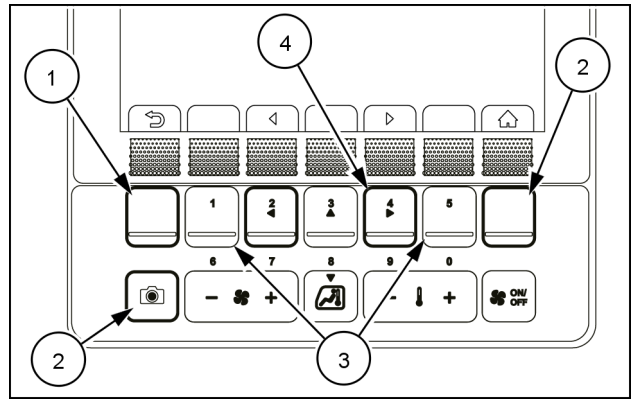

SMIL21CEX3120AA 49

TIME UNTIL REPLACEMENT



Enables you to view the information on the time for replacing the periodic replacement parts.

On the TIME UNTIL REPLACEMENT screen, each page has consumable part items (1) displayed. A replacement cycle (3) is set for each consumable part. The time remaining until replacement is displayed at (2).

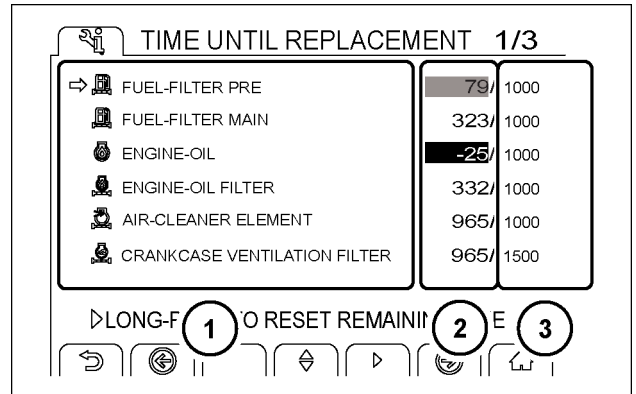

SMIL21CEX3260AA 50

When the time remaining has become **100 h** or less, it is displayed in yellow (1).

When the time remaining has passed **0 h**, it is displayed in red (2).

If this happens, perform service immediately.

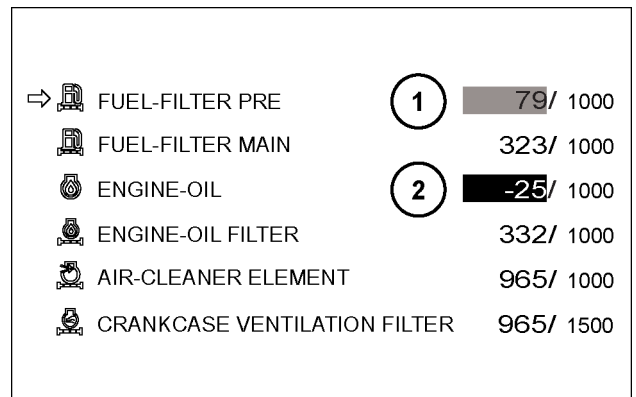

SMIL21CEX3261AA 51

Replace the parts, lubricants, etc. To reset the remaining time, select an item, then press and hold the function switch on the right for **3 s**. An alarm sounds and the time is reset.

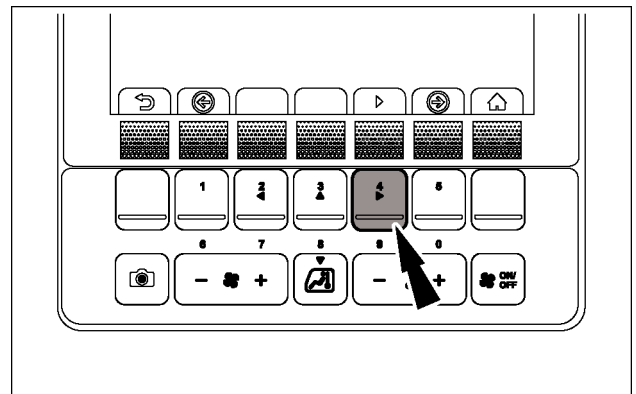

SMIL21CEX3259AA 52

You can check the following consumable part items:

Page	Machine information
1/3	FUEL-FILTER PRE
	FUEL-FILTER MAIN
	ENGINE-OIL
	ENGINE-OIL FILTER
	AIR-CLEANER ELEMENT
	CRANKCASE VENTILATION FILTER
2/3	AIR-BREATHER ELEMENT
	PILOT-OIL FILTER
	RETURN FILTER
	SUCTION FILTER
	HYDRAULIC OIL
3/3	SWING REDUCTION GEAR OIL
	TRAVEL REDUCTION GEAR OIL
	AIR CONDITIONER FILTER

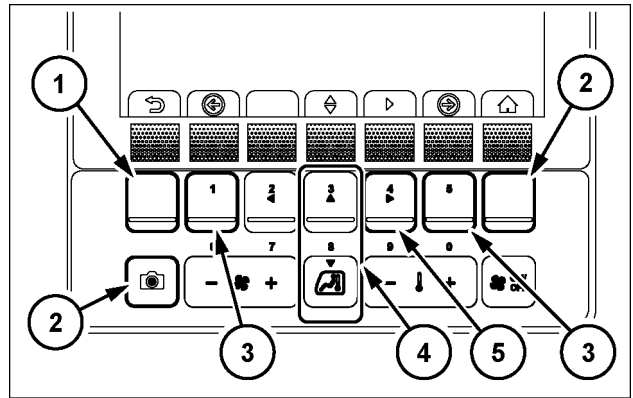

SMIL21CEX3262AA 53

Press **(1)** to return to the menu selection screen. (If the function switch on the normal screen was used to open the TIME UNTIL REPLACEMENT screen, the screen returns to the normal screen.)

Press **(3)** to go forward or back 1 page.

Press **(4)** to move the cursor up or down to select an item.

Press and hold **(5)** for **3 s**. An alarm sounds and the replacement time for the selected item is reset.

Press **(2)** to return to the normal screen.

NOTE: When the screen lock is ON, the cursor cannot be moved up or down to select an item for which you want to reset the remaining time.

NOTE: When the screen lock is ON, the function switch tabs related to **(4)** and **(5)** are not displayed.

NOTIFICATIONS



Enables you to view the information that the operator needs to know.

- Information always notified at start up.
This function notifies the operator of the functions assigned to the control levers switches when the system starts up in order to prevent operator error. If there is any other information to be notified, it will be displayed alternately with the notifications screen.

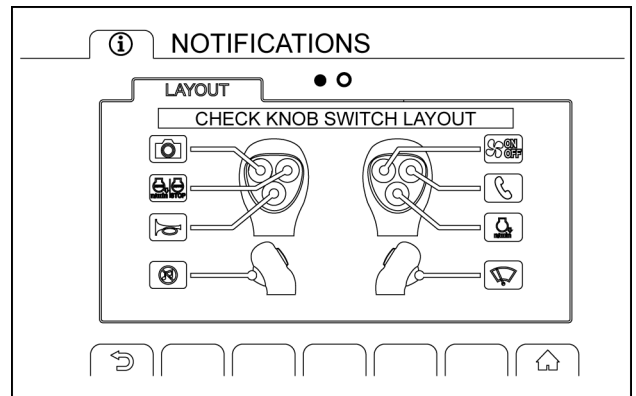

SMIL22CEX1995AA 54

- When there is information to be notified
The messages "RELEASE CONTROL LEVER AND PEDAL" and "SET GATE LOCK LEVER TO CENTRAL POSITION" are displayed when the auto operation lever lock is activated. These messages remain displayed until the auto operation lever lock is released.

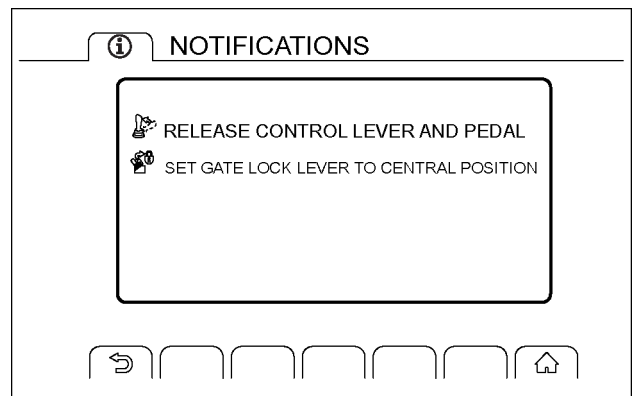

SMIL21CEX3264AA 55

When the auto operation lever lock function setting is OFF, the message "CHECK AUTO LEVER LOCK SETTING" is displayed.

Only a service engineer can turn this setting OFF. If this message is displayed, contact your local dealer or the certified service plant.

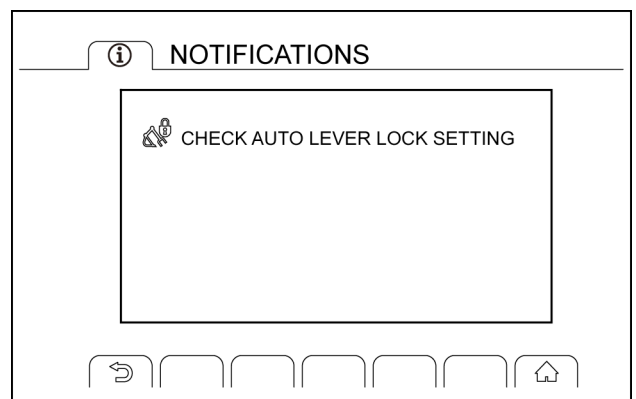

SMIL22CEX1243AA 56

If any flow balance settings have been changed from the standard setting positions (factory settings) with the flow balance customization function, the message "CUSTOM FLOW BALANCE ACTIVE" is displayed when the system is started.

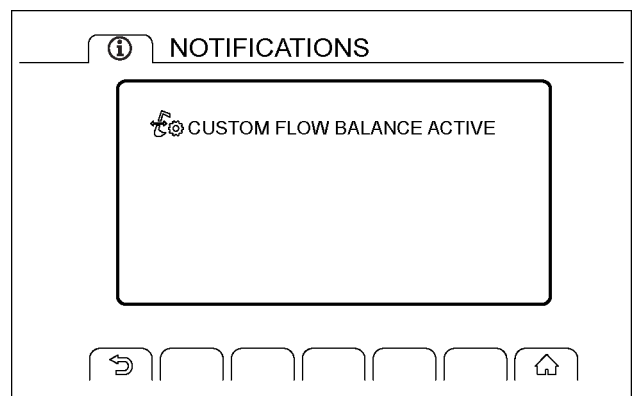

SMIL21CEX3266AA 57

As an example, this section explains the case in which the flow balance customization function is enabled.

- A. Password screen (when manual lock is set up)
- B. Start screen
- C. Notification screen (displayed for **10 s**)
- D. Normal screen

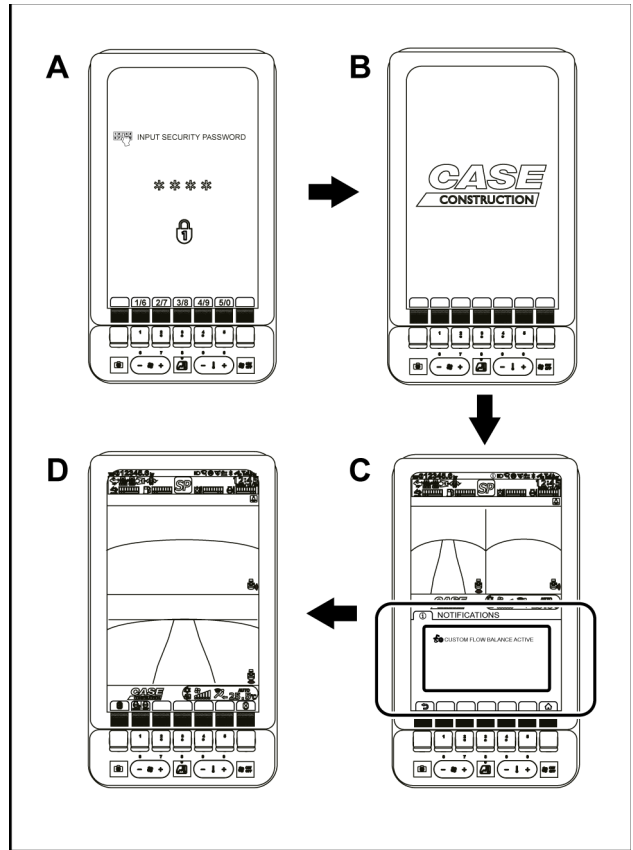

SML21CEX3129BA 58

If the flow balance setting has been changed with the flow balance customization function, a buzzer sounds and the notification screen is displayed for **10 s** every time the system is started.

NOTE: The notification screen displays the event that last occurred. If the auto operation lever lock is activated while the flow balance customization function notification is displayed on the screen, the auto operation lever lock notification is displayed on the screen.

In normal screen mode, an icon is displayed at the top of the monitor screen to indicate that there is information that the operator needs to know.

NOTE: The icon remains displayed even after the message is viewed on the NOTIFICATIONS screen.

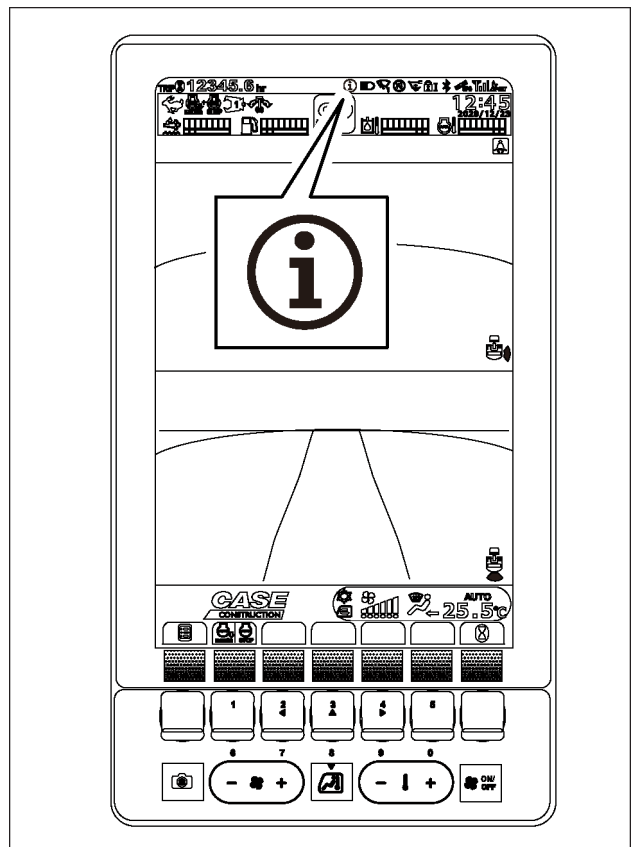

SML21CEX3267BA 59

The message "CUSTOM FLOW BALANCE ACTIVE" is displayed on the NOTIFICATIONS screen, which indicates that the flow balance customization function is enabled.

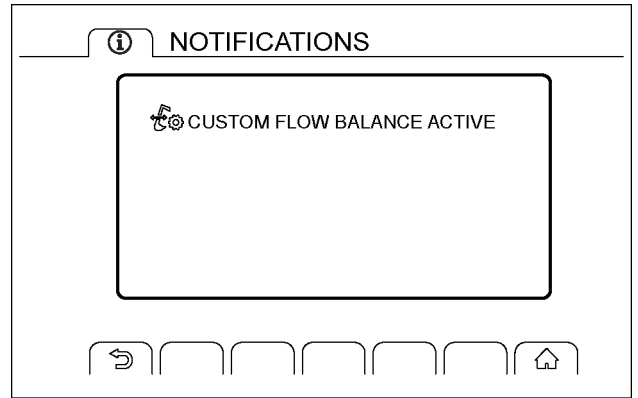

SMIL21CEX3266AA 60

Operating the function switches when the NOTIFICATIONS screen is displayed

Press **(1)** to return to the original screen.

Press **(2)** to return to the normal screen.

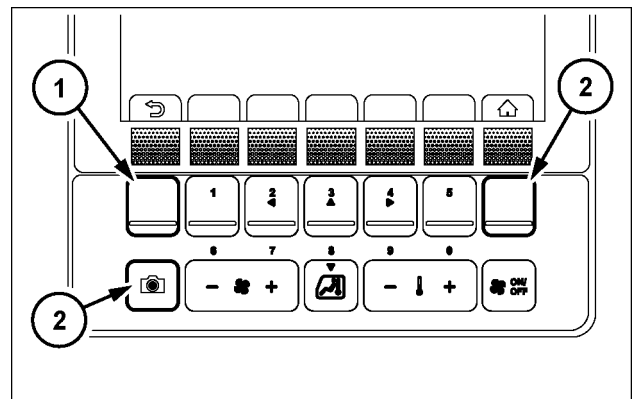

SMIL21CEX3268AA 61

DISPLAY CONFIGURATION



Enables you to configure the screen brightness, camera, and date/time settings.

Items displayed on page 1:

- LANGUAGE: the language displayed on the monitor can be changed.
- Select from the following languages.

1	English
2	Japanese
3	German
4	French
5	Italian
6	Spanish
7	Portuguese
8	Dutch
9	Danish
10	Norwegian
11	Swedish
12	Finnish

13	Russian
14	Canadian French
15	Polish
16	Latin American Spanish
17	Romanian
18	Czech
19	Serbian
20	Croatian
21	Arabic
22	Hebrew
23	Pictographs only

- UNIT (MPa, °C/psi, °F/kgf/cm2, °C)
The unit displayed on the monitor can be changed. Select from the following units:
MPa,
°C psi,
°F kgf/cm2,
°C
- BRIGHTNESS (DAYTIME) (11 levels)
The monitor brightness during the daytime can be adjusted in 11 levels from 0 to 10.
- BRIGHTNESS (NIGHT) (11 levels)
The monitor brightness during night time can be adjusted in 11 levels from 0 to 10.
- CAMERA DIRECTION INDICATOR (ON/OFF)
Whether or not the camera angle on the monitor is displayed can be selected.
- AUTO DIMMER (ON/OFF)
When this is set to ON, the solar radiation sensor detects the ambient light and if it is bright, the monitor brightness is controlled not to decrease even when the working light is turned ON.
- CAMERA GUIDE LINE (ALL/REAR/OFF)
Whether or not the camera guide lines are displayed on camera images can be selected.

NOTE: Camera guide lines are not displayed on FVM (if equipped) camera images.

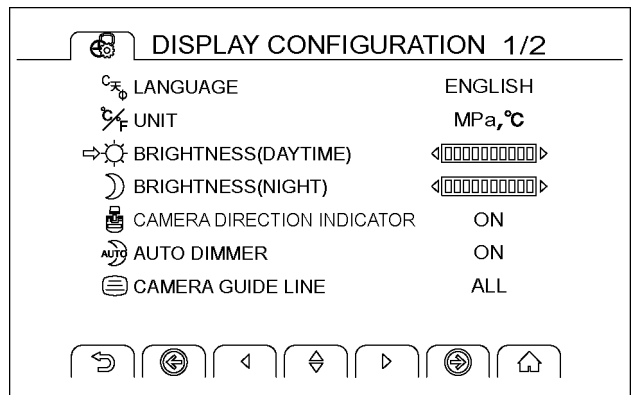

Items displayed on page 2:

- **AUTO TIME ADJUST (OFF)**
With this model, this item is grayed out and cannot be selected.
- **DATE - YEAR**
Enter the year.
- **DATE - MONTH/DAY**
Enter the month and day.
- **TIME - HOUR/MIN.**
Enter the time.
- **DATE FORMAT (Y/M/D, M/D/Y, D/M/Y)**
The date display format can be changed. Select from the following formats. Year/Month/Date – Month/Date/Year – Date/Month/Year
- **TIME FORMAT (12hr, 24hr)**
The time display format can be changed. Select from the following formats. 12-hour format – 24-hour format
- **DAYLIGHT SAVING TIME (ON/OFF)**
When this is set to ON, daylight-saving time is used.

Operation explanation for function switches. Press **(1)** to return to the menu selection screen. (If the function switch on the normal screen was used to open the DISPLAY CONFIGURATION screen, the screen returns to the normal screen.)

Press **(2)** to return to the normal screen.

Press **(3)** to go forward or back 1 page.

Use the switches **▲▼ (4)** to move the cursor up and down to select an item, then use the switches **◀▶** to change the setting.

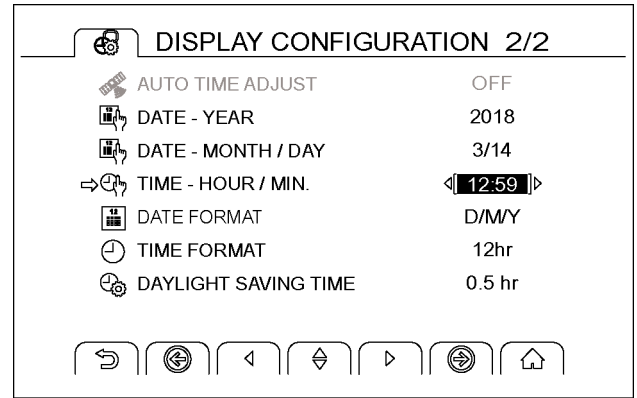

SMIL21CEX3270AA 63

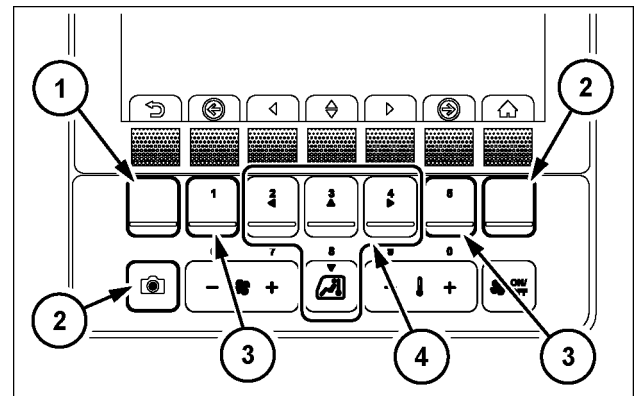

SMIL21CEX3271AA 64

ATS CONFIGURATION



Enables you to view and change the ATS settings.

The following items can be configured or viewed.

- **AUTO ATS CLEANING STOP (ON/OFF)** The temperature of the exhaust gas produced during automatic ATS cleaning is high, therefore it is dangerous to perform automatic ATS cleaning inside a building (including tunnels) or other locations with fire and explosion risks. If you want to pause ATS cleaning that has already started, change this item to "ON".

NOTE: "AUTO ATS CLEANING STOP" can be changed to ON only while automatic cleaning is in progress. "AUTO ATS CLEANING STOP" cannot be turned ON before automatic cleaning starts.

- **MANUAL ATS CLEANING MODE (ON/OFF)** Set this to ON to perform manual ATS cleaning.

Operation explanation for function switches

Press **(1)** to return to the menu selection screen.

Press **(2)** to return to the normal screen

Use the switches **▲▼ (3)** to move the cursor up and down to select an item, then use the switches **◀▶** to change the setting.

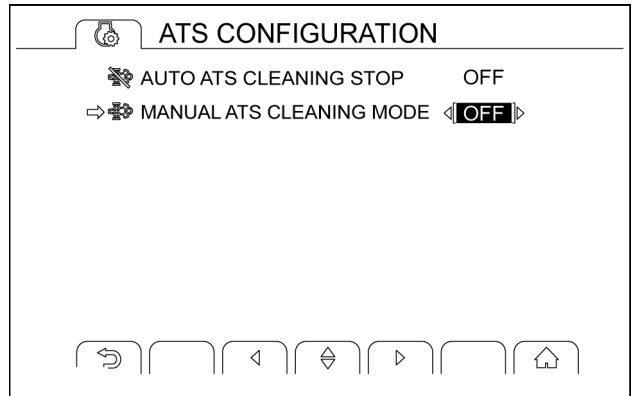

SML21CEX3136AA 65

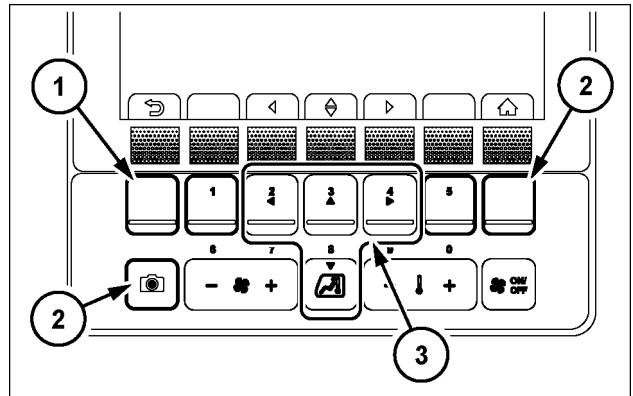

SML21CEX3292AA 66

FUNCTION CONFIGURATION



Enables you to configure settings for functions related to energy-saving and safety.

Enables you to view and change the settings for each item.

Items displayed on page 1:

- **AUTO IDLE (ON/OFF)** Reduces the engine speed when the machine has been left unoperated longer than the set time in seconds. Allows you to turn ON or OFF this function.
- **AUTO IDLE TIMER (5 s/ 10 s/ 15 s/ 30 s)**
Allows you to set the time in seconds until the system enters the auto idle mode.
- **IDLE STOP (ON/OFF)** Non-operation position (with the safety bar stored in the console) The engine speed is **1200 RPM** or less.
The throttle operation has not been performed longer than the set time in minutes. When the above conditions are met, the message "IDLE SHUT DOWN" is displayed on the screen and an alarm sounds, then the engine stops in **10 s**.
Allows you to turn ON or OFF this function.
- **IDLE STOP TIMER (3 min/ 5 min/ 7 min/ 10 min)**
Allows you to set the time in minutes until idle shutdown occurs.
- **LIGHT OFF TIMER (0 s/ 15 s/ 30 s/ 60 s/ 90 s/ 120 s/ 150 s/ 180 s)**
Allows you to set the time until the lights go out after the working light is turned OFF.

NOTE: When **AUTO IDLE** is set to **OFF**, **AUTO IDLE TIMER** cannot be set.

NOTE: When **IDLE STOP** is set to **OFF**, **IDLE STOP TIMER** cannot be set.

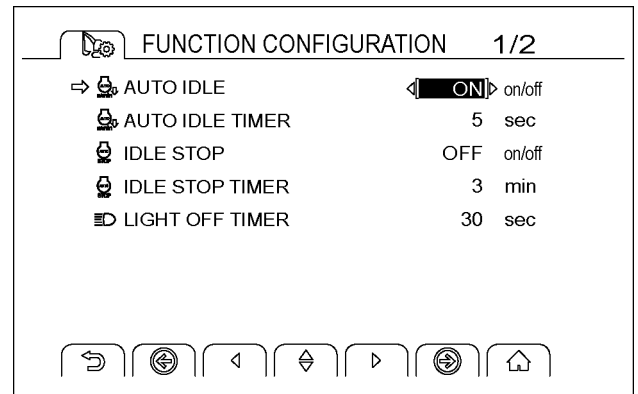

SMIL21CEX3293AA 67

Items displayed on page 2:

NOTE: Page 2 is for machine administrators and the settings can be locked with a passcode.

- TRAVEL ALARM TIME (10 s/ 20 s/ 30 s/ 60 s/ ∞ s) Allows you to set how long the warning buzzer sounds in seconds during travel operation.
- WORK MODE LIMITATION (SP P E/P E/E) Allows you to set a limitation so that the operator does not perform operations in an inappropriate work mode.

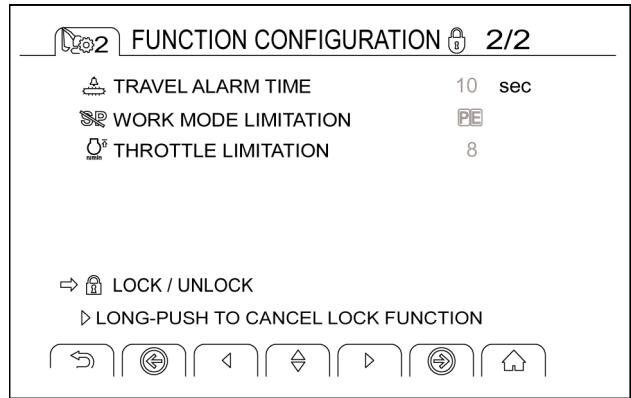

SMIL21CEX3134AA 68

Descriptions of icons for WORK MODE LIMITATION

Allows you to use all work modes. When this mode is selected, the maximum speed setting cannot be changed with "THROTTLE LIMITATION".

Prevents you from using the SP mode. When this mode is selected, the maximum speed settings for the P mode and E mode can be changed with "THROTTLE LIMITATION".

NOTE: When the SP mode is selected, a buzzer sounds and the text message "WORK MODE LIMITATION ACTIVE" is displayed for 3 s.

Allows you to use all work modes. When this mode is selected, the maximum speed setting cannot be changed with "THROTTLE LIMITATION".

NOTE: When the SP mode or P mode is selected, a buzzer sounds and the text message "WORK MODE LIMITATION ACTIVE" is displayed for 3 s.

- THROTTLE LIMITATION (6/7/8/9/10). Allows you to change the maximum speed setting for the work mode.

NOTE: If you attempt to increase the speed with the engine throttle volume beyond the set maximum speed, a buzzer sounds and the message "THROTTLE LIMITATION ACTIVE" is displayed for 3 s.

NOTE: When "SP P E" is selected for "WORK MODE LIMITATION", this item cannot be selected.

Locking/unlocking with a passcode

Select "LOCK/UNLOCK" (1) displayed on page 2, then press and hold the right function switch for 3 s.

An alarm sounds and the passcode entry screen opens.

After the passcode (2) is successfully entered, you can set whether to lock or unlock items.

Use the switches ▲▼ to move the cursor up and down to select the item (3) you want to change the setting for, then use the switches ◀▶ to change the setting.

NOTICE: The factory setting for the passcode is "1560".

NOTICE: If you forgot the set passcode, consult your local dealer or the certified service plant.

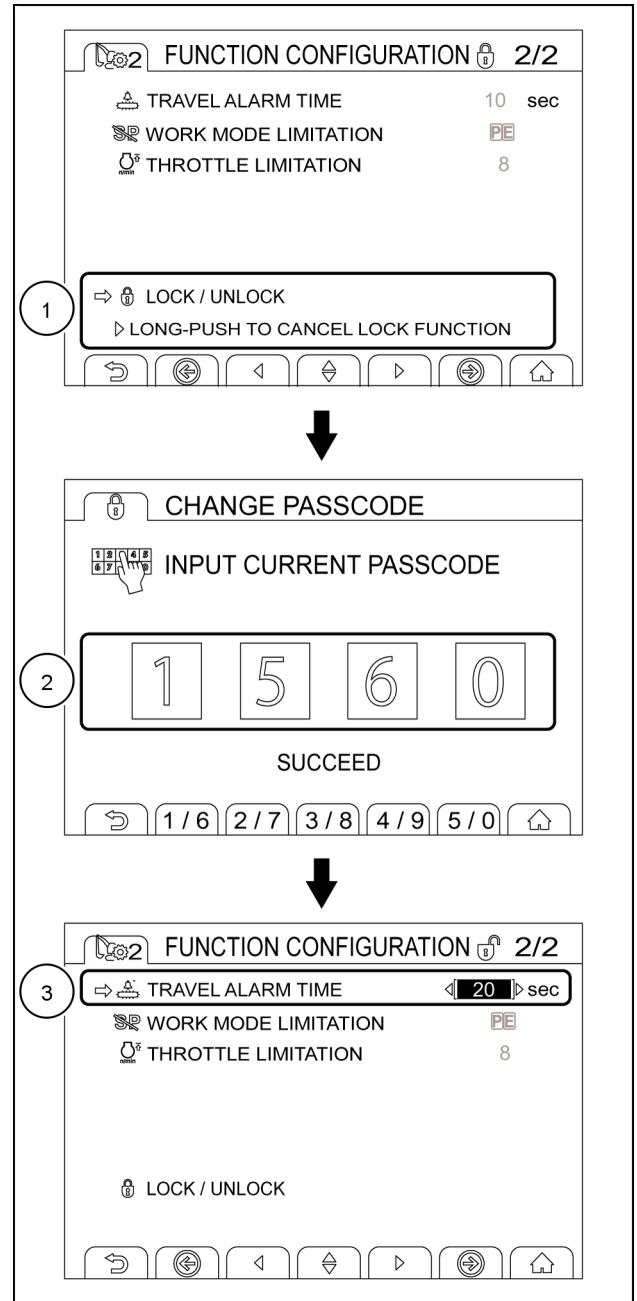

Operation explanation for function switches

Press **(1)** to return to the menu selection screen. (If the function switch on the normal screen was used to open the FUNCTION CONFIGURATION screen, the screen returns to the normal screen.)

Press **(2)** to return to the normal screen.

Press **(3)** to go forward or back 1 page.

Use the switches **▲▼ (4)** to move the cursor up and down to select an item, then use the switches **◀▶** to change the setting.

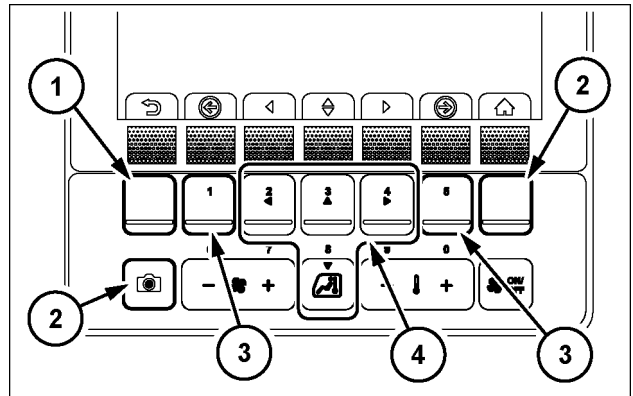

SMIL21CEX3271AA 70

CUSTOM FLOW BALANCE



Enables you to adjust the flow balance according to the end attachment to be used. Adjusting the flow balance can contribute to smoother operation and improved operability for leveling work.

When you select CUSTOM FLOW BALANCE, the message "HYDRAULIC FLOW BALANCE WILL BE CUSTOMIZED IN THIS MENU" is displayed on the screen. Select "CONTINUE" to change the settings.

NOTICE: The flow balance changes when the settings are changed. Perform operational checks before operating the machine after changing the setting.

The following items can be configured.

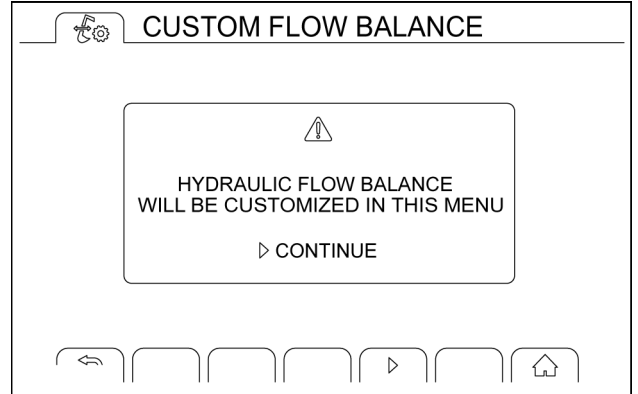

SMIL21CEX3132AA 71

ARM IN AND BOOM UP COMBINATION LEVELING

Adjusting the flow balance changes the pump flow balance between arm-in and boom-up operations, which allows you to select your desired flow balance.

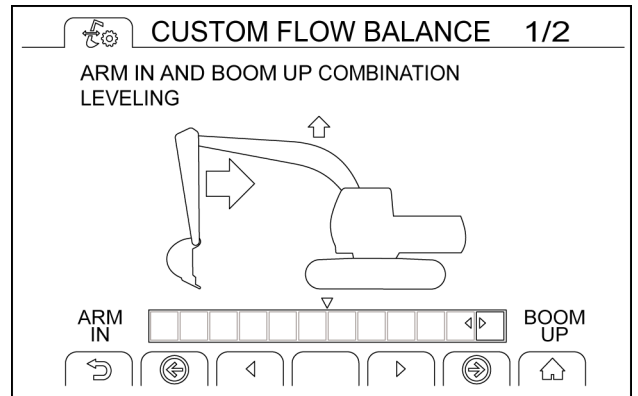

SMIL22CEX1996AA 72

Flow balance gauge

The size of the arrow icon displayed changes as the flow balance gauge increases or decreases.

NOTICE: The white ▽ mark at the top of the flow balance gauge shows the standard setting position (factory setting). The flow balance changes when the setting is changed to a position significantly away from the standard setting position. Perform operational checks before operating the machine after changing the setting.

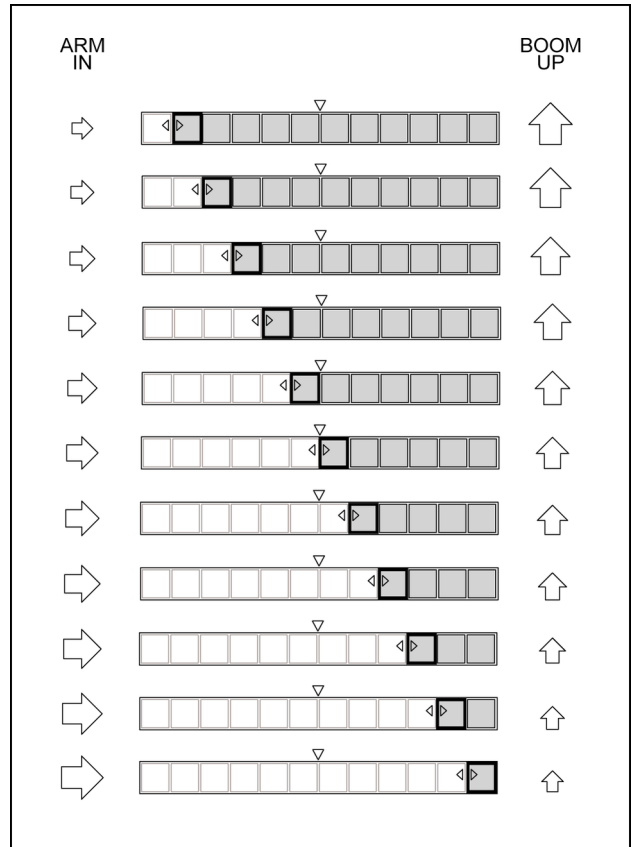

SMIL22CEX1997BA 73

ARM IN AND SWING COMBINATION

Adjusting the flow balance changes the pump flow balance between arm-in and swing operations, which allows you to select your desired flow balance.

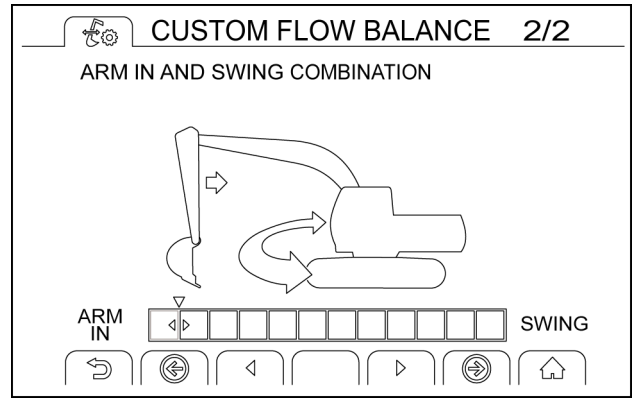

SMIL22CEX1998AA 74

Flow balance gauge

The size of the arrow icon displayed changes as the flow balance gauge increases or decreases.

NOTICE: The white ▽ mark at the top of the flow balance gauge shows the standard setting position (factory setting). The flow balance changes when the setting is changed to a position significantly away from the standard setting position. Perform operational checks before operating the machine after changing the setting.

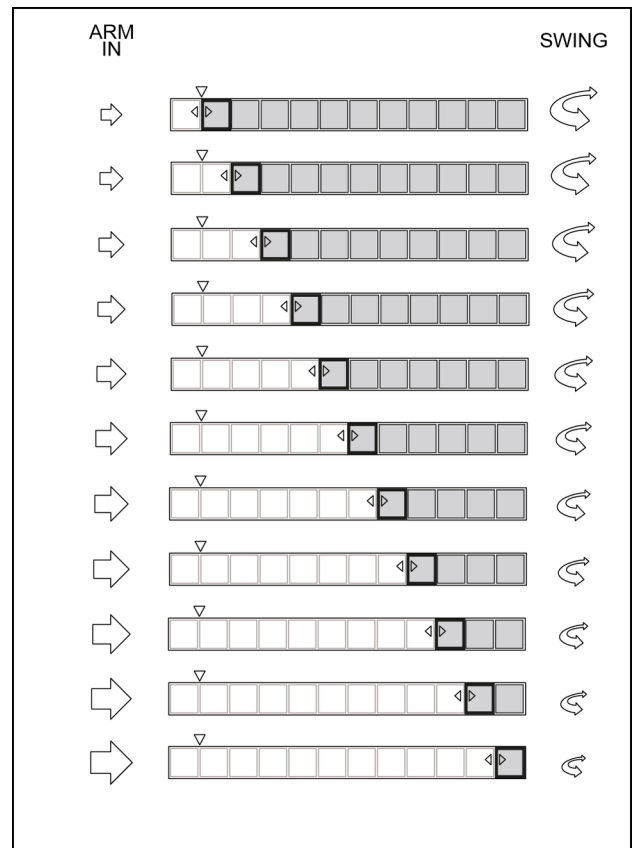

SMIL21CEX3130BA 75

After changing the setting, the notification screen is displayed every time the system is started.

- A. Passcode screen (when manual lock is set up)
- B. Start screen
- C. Notification screen (displayed for **10 s**)
- D. Normal screen

If the flow balance setting has been changed with the flow balance customization function, the notification screen is displayed for **10 s** every time the system is started.

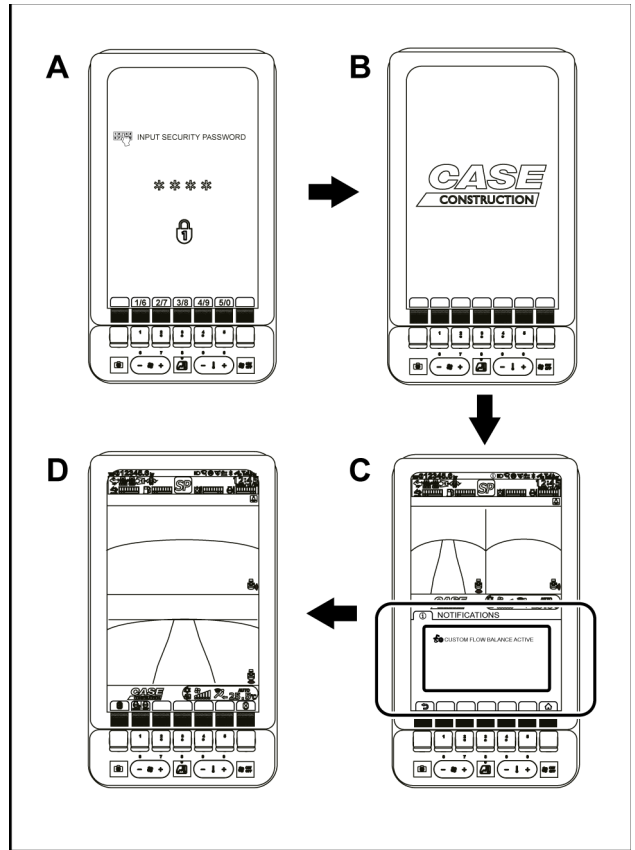

SMIL21CEX3129BA 76

Press **(1)** to return to the menu selection screen. (If the function switch on the normal screen was used to open the DISPLAY CONFIGURATION screen, the screen returns to the normal screen.)

Press **(2)** to return to the normal screen.

Press **(3)** to move the cursor to change the setting.

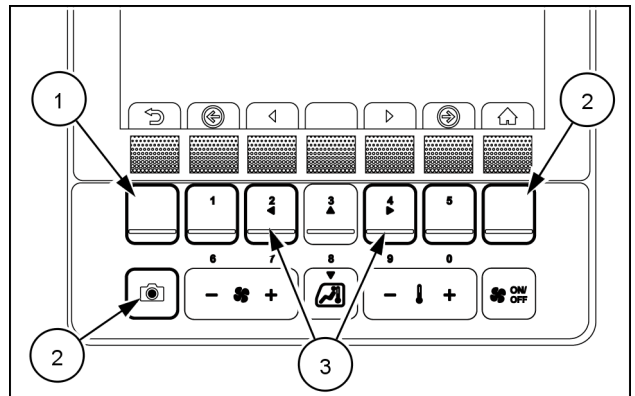

SMIL21CEX4355AA 77

MONITOR SWITCHES LAYOUT



Enables you to create shortcuts for frequently used menu screen items on the function switch tab in normal display mode.

NOTE: The illustration provided shows the factory settings.

No.	Name
1	IDLE MODE SETTING
2	RADIO MUTE
3 - 4	BLANK

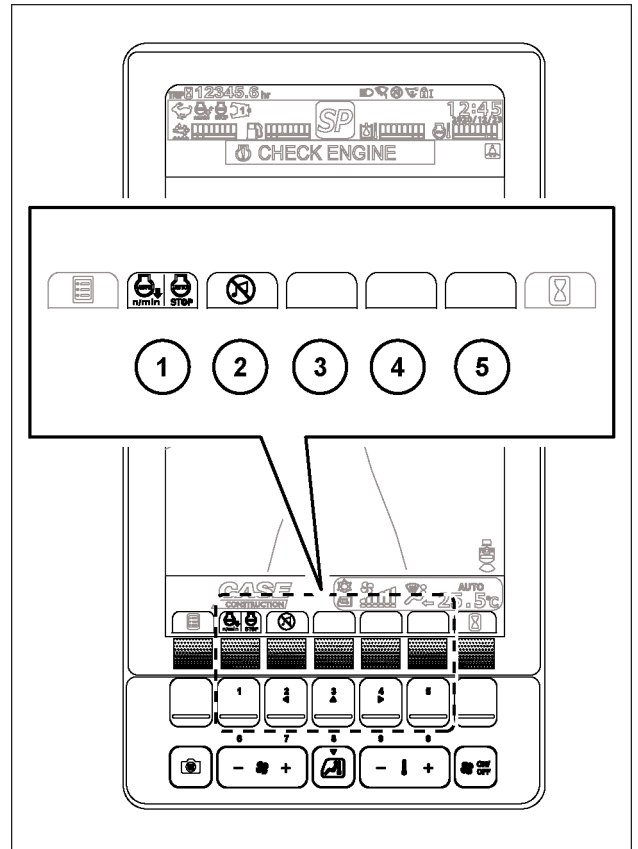

SMIL21CEX3296BA 78

In user information mode, select Monitor Switches Layout and follow the steps below to change the settings.

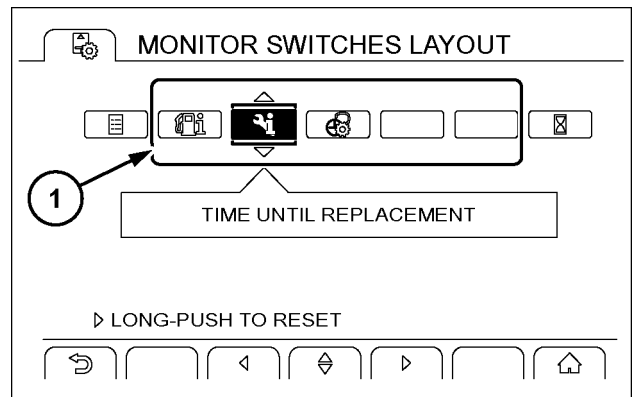

Use the function switches ◀▶ to select the tab (1) you want to change, then use the function switches ▲▼ to select an icon.

NOTE: The settings for the function switch tabs on both ends are fixed and cannot be changed.



SMIL21CEX3297AA 79

Resetting the settings

When you press the function switch , the tab **(1)** to be reset is highlighted in yellow and then the callout disappears. Then, press and hold the function switch  for **3 s**. An alarm sounds to complete the reset. The settings are reset to the factory settings.

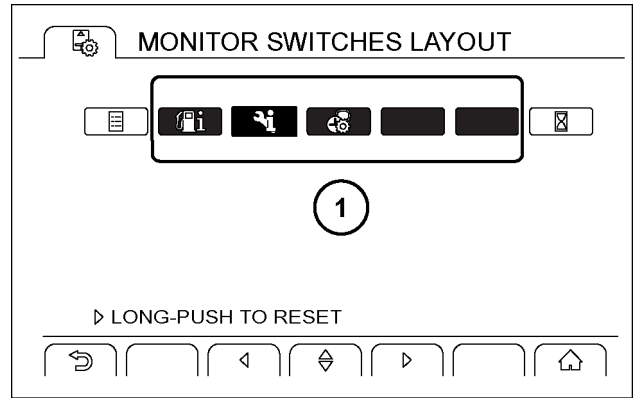

SMIL21CEX3298AA 80

Descriptions of icons for MONITOR SWITCHES LAYOUT



FUEL CONSUMPTION: Enables you to view the fuel economy for the past 7 days.



MACHINE INFORMATION: Enables you to view the machine status in detail.



TIME UNTIL REPLACEMENT: Enables you to view the information on the time for replacing the periodic replacement parts.



NOTIFICATION: Enables you to view the information that the operator needs to know.



DISPLAY CONFIGURATION: Enables you to configure the screen brightness, camera, and date/time settings.



AUXILIARY HYDRAULICS: Enables you to switch between Breaker and Crusher, manage operations according to the model, and set the pressure and flow rate.



ATS CONFIGURATION: Enables you to view and change the ATS settings.



FUNCTION CONFIGURATION Enables you to configure settings for functions related to energy-saving and safety.



CUSTOM FLOW BALANCE Enables you to adjust the flow balance according to the end attachment to be used.



MONITOR SWITCHES LAYOUT: Enables you to create shortcuts for frequently used menu screen items on the function switch tab in normal display mode.



FACTORY SETTINGS: Enables you to reset the settings on the menu screen to the factory settings all at once.



PASSCODE SETTING
Enables you to change the passcode.



IDLE MODE SETTING: Switches the idle mode settings.



RADIO MUTE: Turns ON or OFF the radio audio output.

BLANK: Leaves a tab blank.

Operation explanation for function switches

Use the switches ▲▼ (3) to move the cursor up and down to select an item, then use the switches to change the setting.

Press and hold the switch ◀▶ for 3 s to reset the settings.

Press (1) to return to the menu selection screen. (If the function switch on the normal screen was used to open the DISPLAY CONFIGURATION screen, the screen returns to the normal screen.)

Press (2) to return to the normal screen.

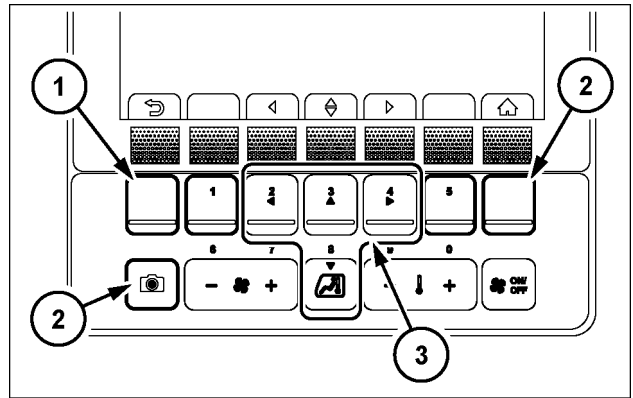

SMIL21CEX3292AA 81

KNOB SWITCHES LAYOUT



Enables you to change the switch function of the control levers.

How to set the Knob Switches Layout from User Information Mode:

Use the function switches ▲▼ to select the switch (2) you want to change, then use the function switches ◀▶ to select the function (1) you want to change. The selected function name is displayed in (3).

NOTE: The grayed-out icon is a fixed setting and cannot be changed.

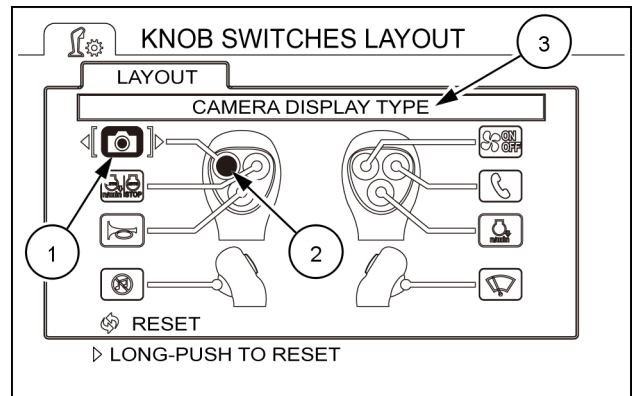

SMIL22CEX1968AA 82

Descriptions of Knob Switches Layout functions



ONE TOUCH WIPER: the wiper blade moves back and forth while the switch is held down.



RADIO MUTE: press this switch to turn the radio sound output ON or OFF.



HANDS FREE PHONE: by connecting your cellular phone via Bluetooth, you can answer calls with the knob switches.



CAMERA DISPLAY TYPE: press this switch to switch the camera display type.



WINDSHIELD WASHER: washer and wipers operate while the switch is held down. When you let go of the switch, they stop.



A/C POWER: press this switch to turn air conditioner ON or OFF.



A/C AUTO MODE: press this switch to switch to the auto mode of the air conditioner.



HOUR METER AND TRIP: press this switch to switch between the hour meter display and trip display.



A/C DEFROSTER: press this switch to switch to defroster mode.



IDLE MODE: press this switch to switch the idle mode.



BLANK: set as blank.

Reset the settings

When you select the RESET item (1) and press the function switch, all the icons to be reset are highlighted in yellow.

Press and hold the function switch for **3 s** to sound an alarm and complete the reset. After resetting, the settings will be the factory settings.

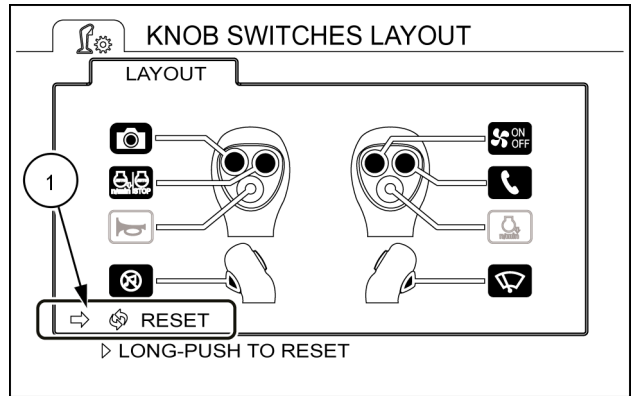

SMIL22CEX1983AA 83

Factory settings

4 switches control levers

	Function name	Remarks
(1)	CAMERA DISPLAY TYPE	Press this switch to switch the camera display type.
(2)	HANDS FREE PHONE	By connecting your cellular phone via Bluetooth, you can answer calls with knob switches.
(3)		Press this switch to sound the horn.
(4)	RADIO MUTE	Press this switch to turn the radio sound output ON or OFF.
(5)	A/C POWER	Press this switch to turn air conditioner ON or OFF.
(6)	WINDSHIELD WASHER	Washer and wipers operate while the switch is held down. When you let go of the switch, they stop.
(7)		Press this switch to shift to/to recover from idle mode.
(8)	ONE TOUCH WIPER	The wiper blade moves back and forth while the switch is held down.

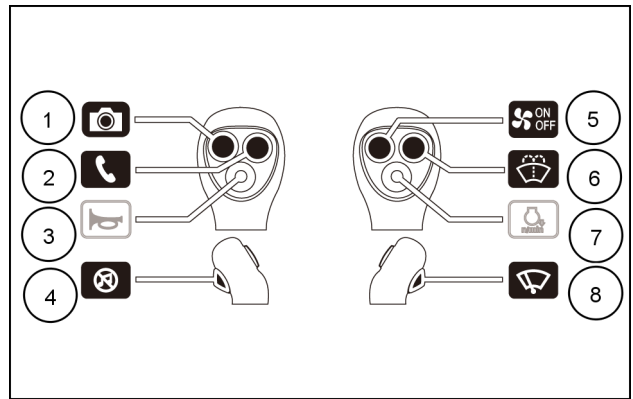

SMIL22CEX1970AA 84

NOTE: The grayed out icon is fixed and only the icon will be displayed without displaying the function name.

Proportional control levers

	Function name	Remarks
(1)		Press this switch to operate the optional devices.
(2)		Press this switch to sound the horn.
(3)		Press this switch to operate the optional devices.
(4)	RADIO MUTE	Press this switch to turn the radio sound output ON or OFF.
(5)		Press this switch to operate the optional devices.
(6)		Press this switch to shift to recover from idle mode.
(7)		Press this switch to operate the optional devices.
(8)	ONE TOUCH WIPER	The wiper blade moves back and forth while the switch is held down.

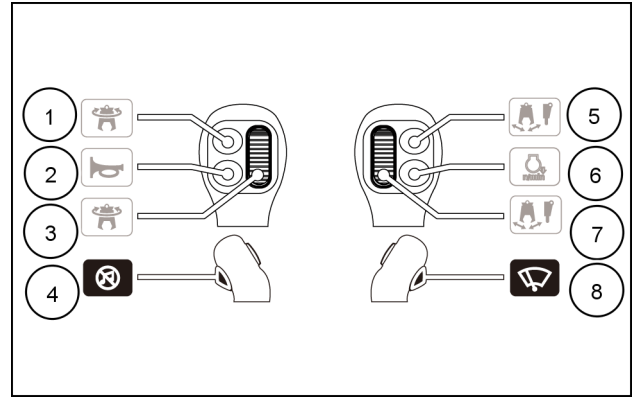

SMIL22CEX1971AA 85

NOTE: The grayed out icon is fixed and only the icon will be displayed without displaying the function name.

Knob switches notification screen

Notifications are made at system startup to correctly notify the functions assigned to knob switches and to prevent operator error.

If there is any other information to be notified, it will be displayed at system startup alternately with the information notification screen at system startup.

- A. Password screen (if manual lock is set)
- B. Start screen
- C. Notification screen: Display for **10 s** for single notification. If there are other notifications to be made using the information screen, they are displayed alternately for **5 s** each, and displayed in two rounds.
- D. Normal screen

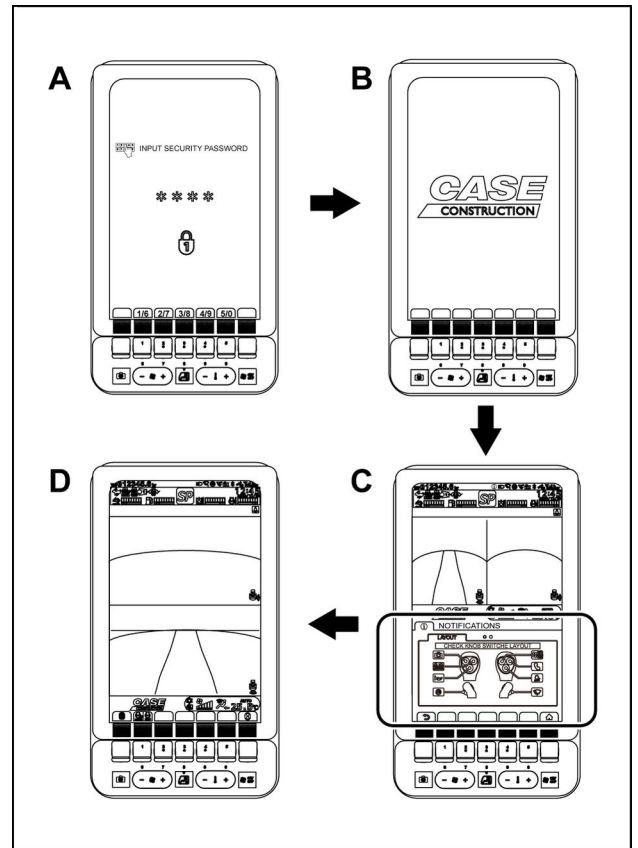

SMIL22CEX1972BA 86

PASSCODE SETTING



Enables you to change the passcode.

- Change the passcode.
Select "CHANGE PASSCODE" (1), then press and hold the switch on the right for **3 s** to open the passcode entry screen.
Use the function switch to enter the passcode on the entry screen (2). When the correct passcode is entered, "SUCCEED" is displayed and the CHANGE PASSCODE screen is displayed.

If the passcode is incorrect, "FAILED" is displayed for **1 s** and the screen returns to the passcode entry screen.
Use the function switch to enter a new passcode on the entry screen (3). "CHANGED" is displayed for **1 s** and the screen returns to the PASSCODE SETTING screen. This completes the passcode change.

NOTICE: The factory setting for the passcode is "1560".

NOTICE: If you forgot the set passcode, consult your local dealer or the certified service plant.

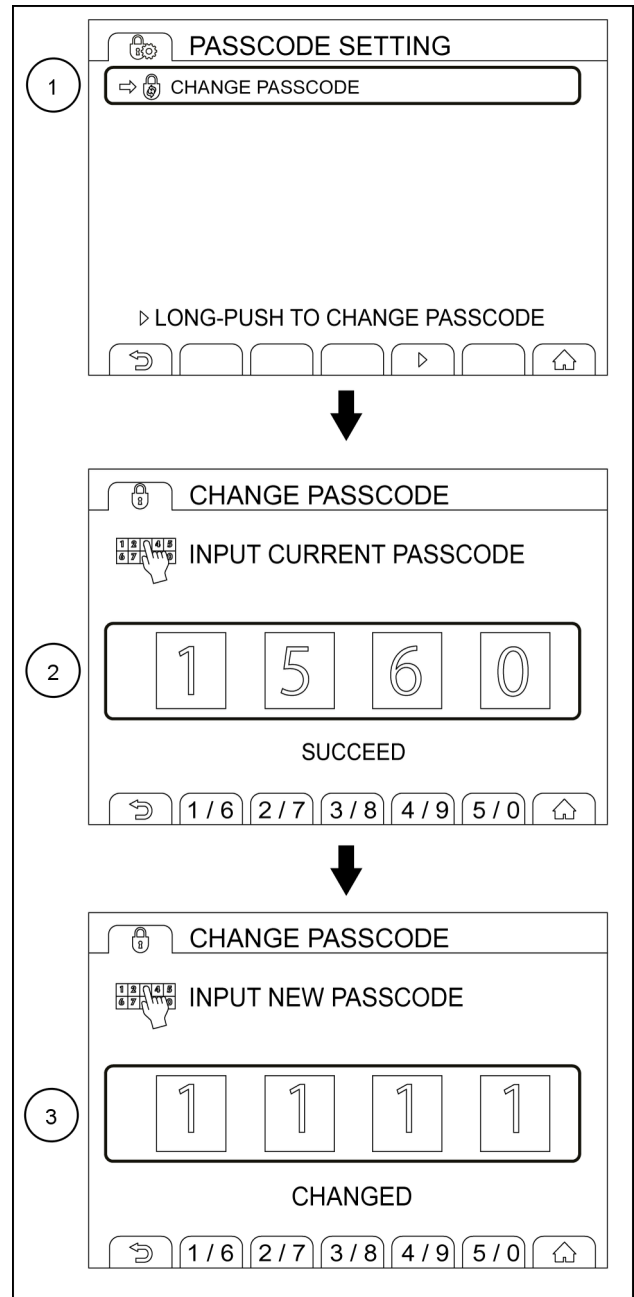

SMIL22CEX1999CA 87

Use the function switches to enter a new passcode on the entry screen **(3)**. This completes the passcode change. To enter numeric values, use the function switches as numeric keys.

Press **(1)** to return to the menu selection screen. (If it is pressed during passcode entry, the passcode entered is discarded and the screen returns to the menu screen.)

Press **(2)** to return to the normal screen. (If it is pressed during passcode entry, the passcode entered is discarded and the screen returns to the normal screen.)

Press **(3)** to enter the passcode. (Press and hold the No.4 key on the PASSCODE SETTING screen for **3 s**. The CHANGE PASSCODE screen is displayed.)

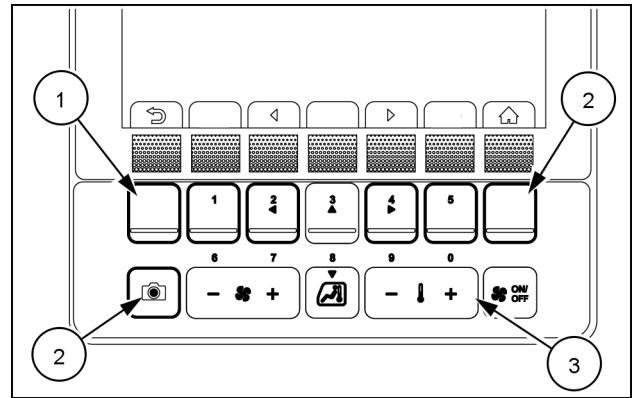

SMIL21CEX4355AA 88

FACTORY SETTING



The settings on the menu screen can be reset all at once.

- Reset the settings

Use the up or down switch to select "RESET TO FACTORY SETTINGS" (1), then press and hold the switch on the right for **3 s**. An alarm sounds and the settings are reset.

NOTE: When the screen is locked, the icon is grayed out and reset cannot be performed.

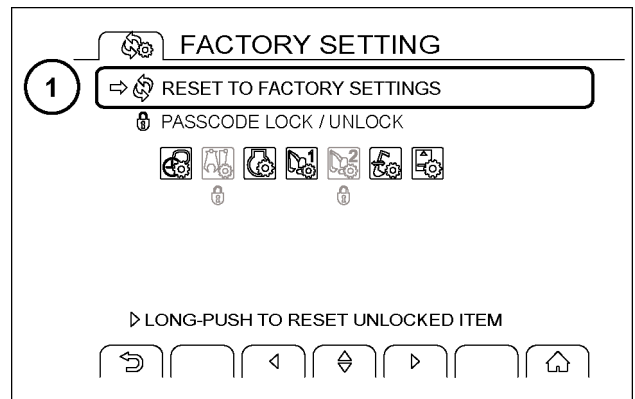

SMIL21CEX3300AA 89

- Lock/unlock the passcode

Use the up or down switch to select "PASSCODE LOCK/ UNLOCK" (1), then press and hold the switch on the right for 3 s. An alarm sounds and the passcode entry screen is displayed. When the correct passcode is entered, a screen opens where you can lock or unlock the settings. Use the left or right switch to select an item and use the up or down switch to change the lock icon between lock and unlock (3).

Press the return switch to return to the first page of the FACTORY SETTING screen.

NOTE: When the screen is locked, the icon is grayed out and reset cannot be performed.

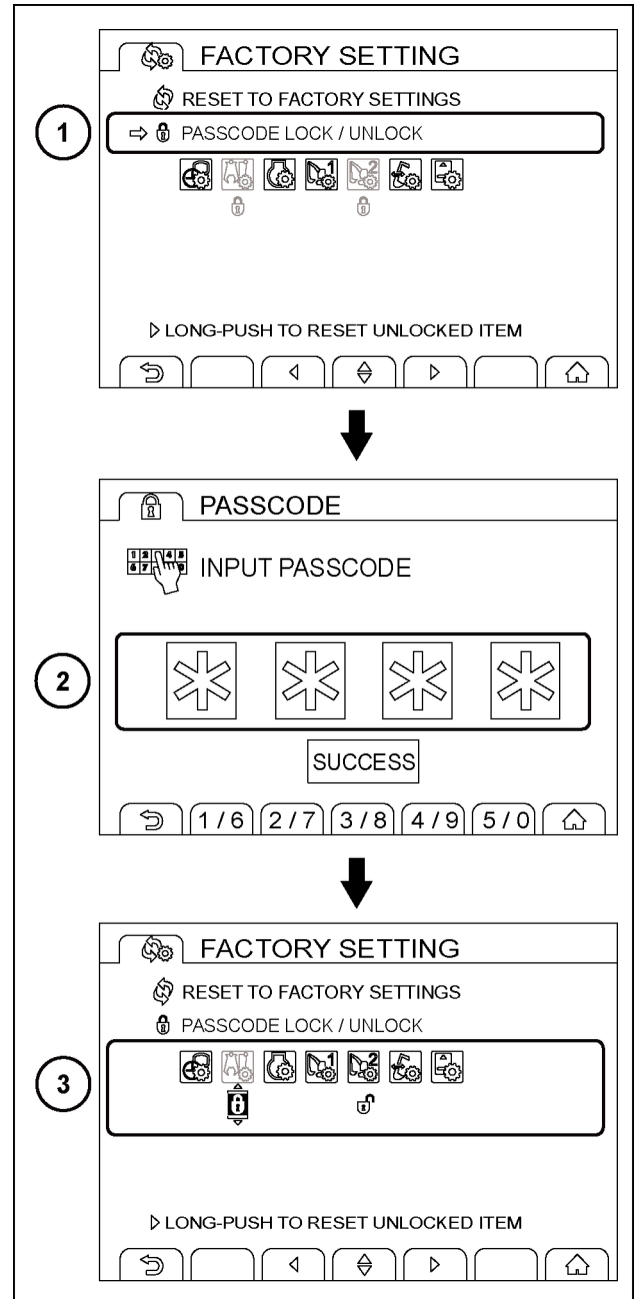

Press **(1)** to return to the menu selection screen. (If the function switch on the normal screen was used to open the FACTORY SETTING screen, the screen returns to the normal screen.)

Press **(2)** to return to the normal screen.

Press **(3)** to select an item or change settings.

Press **(4)** to enter the passcode.

NOTE: When the screen is locked, the up and down function switches and left function switch cannot be used.

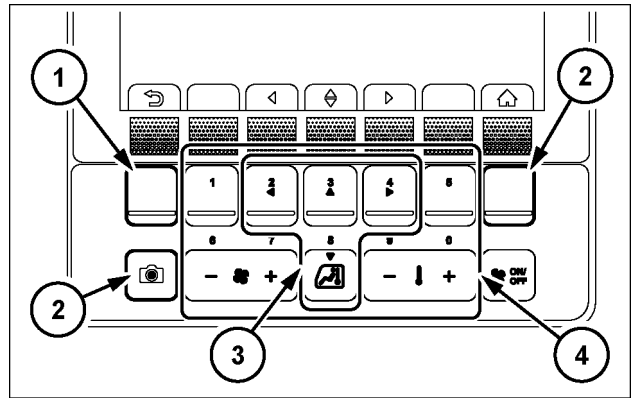

Heating, ventilation or air-conditioning control

Air conditioner control

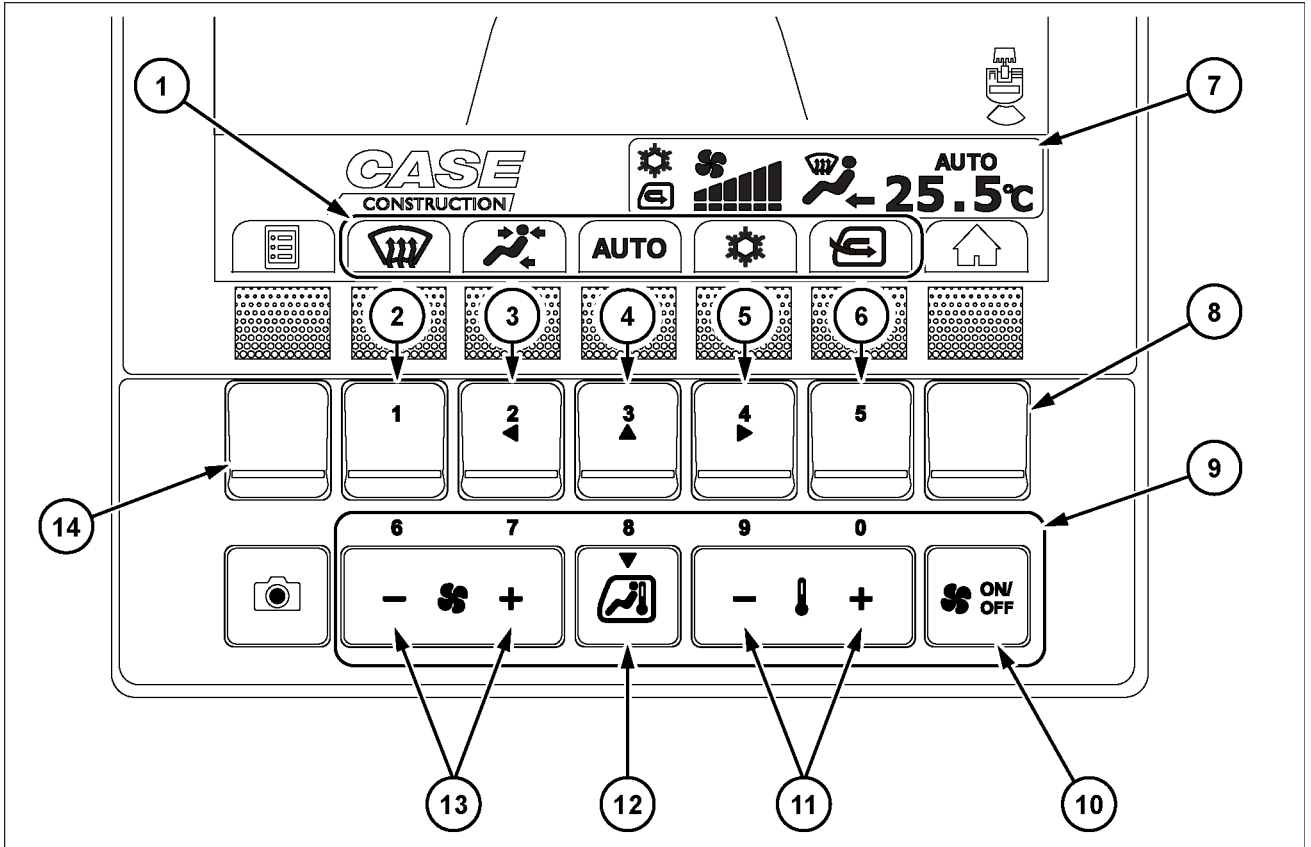

SML21CEX4303FA 1

- | | |
|--|-------------------------------------|
| 1. Function switch tab for operating the air conditioner | 8. Home |
| 2. Windshield defroster | 9. Switches for the air conditioner |
| 3. Air flow direction | 10. Blower ON/OFF |
| 4. Auto | 11. Temperature |
| 5. Air conditioner | 12. Air conditioner mode |
| 6. Air circulation | 13. Blower air flow |
| 7. Display screen | 14. Menu |

Air conditioner operation mode

When you press one of the air conditioner switches (9), the system enters the air conditioner operation mode and the blue function switch tab (1) for air conditioner operations is displayed.

When the air conditioner mode switch (12) or function switches (8) and (14) are pressed or 10 s have passed without any operations performed, the air conditioner operation mode is canceled.

- When the system is turned "ON", it operates with the same setting as the one selected previously.
- When a menu screen or menu selection bar is displayed, the function switch tabs for air conditioner operations are not displayed.

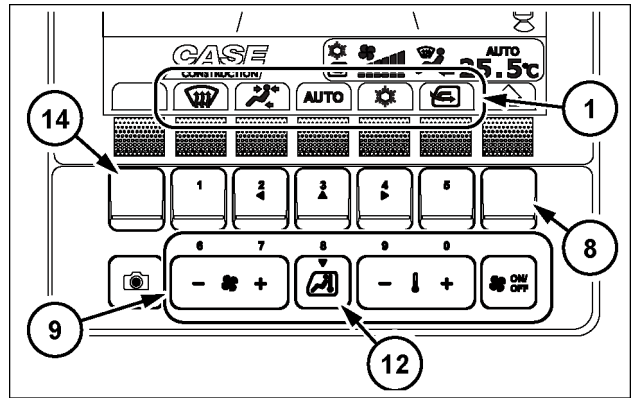

SMIL21CEX4304AA 2

Air flow

Press the blower switch (10) to turn the blower ON or OFF. Press the 2 switches (13) to adjust the strength of the air flow.

Press the right switch to increase the air flow.

Press the left switch to decrease the air flow.

The selected air flow is shown on the display screen (7).

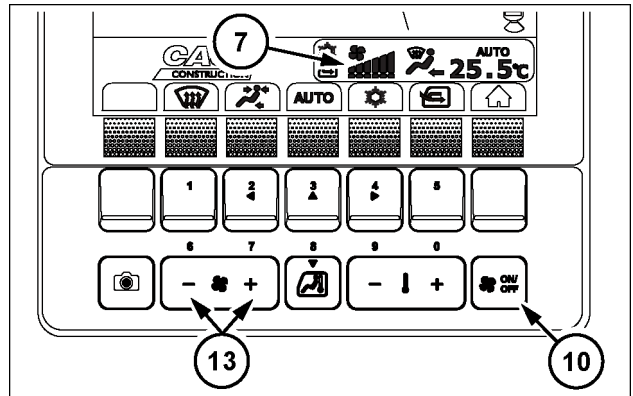

SMIL21CEX4305AA 3

Temperature

The temperature can be set from 18.5 – 31.5 °C (65.3 – 88.7 °F) by using the 2 switches (11).

Press the right switch to increase the set temperature.

Press the left switch to decrease the set temperature.

The set temperature is shown on the display screen (7).

NOTICE: The temperature can be displayed in Celsius or Fahrenheit. The display can be changed in the monitor display settings.

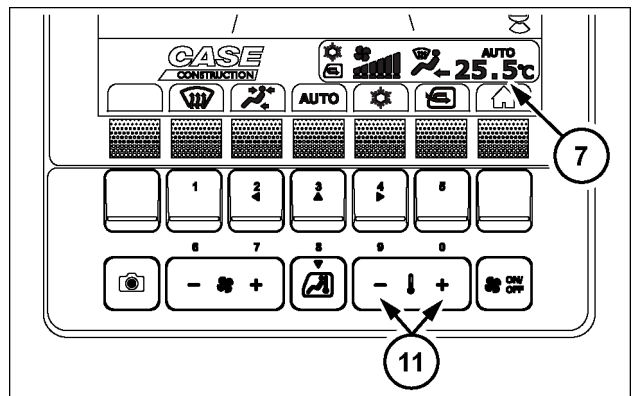

SMIL21CEX4306AA 4

Air circulation

Press the function switch (6) to select either of 2 types of air circulation, refresh or recirculate.

The air circulation type changes each time this switch is pressed.

The selected air circulation type is shown on the display screen (7).

A. Recirculate

B. Refresh

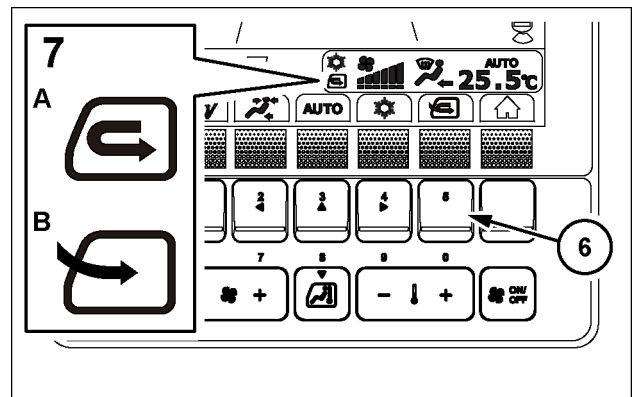

SML21CEX4307AA 5

Air flow direction

Press the function switch (3) to select an air flow direction from ① to ⑤ in the table.

The air flow direction type changes each time the switch is pressed.



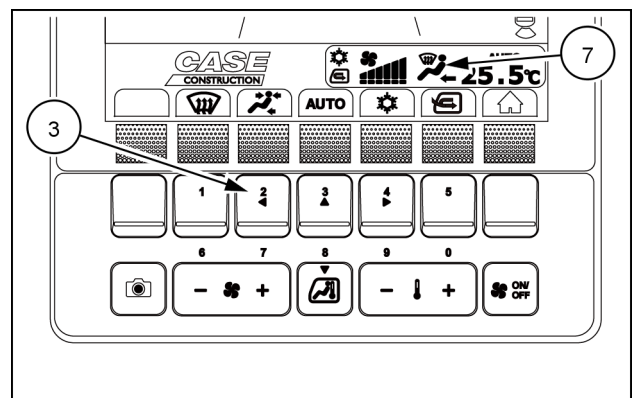

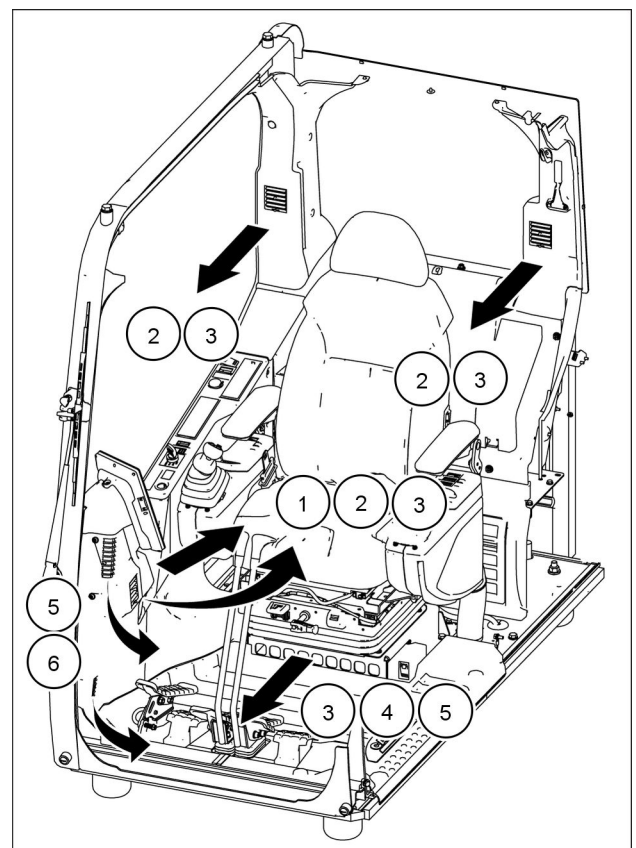

The selected direction type is shown on the display screen (7).



SML21CEX4356AA 6



SML21CEX3122BA 7

	LCD display	Air vent	Air vent direction
①		Face 1	Front of upper half of body
②		Face 2	Front and rear of upper half of body
③		Bi-level	Front and rear of upper half of body Feet
④		Foot	Feet
⑤		Foot/defroster	Windshield Feet
⑥		Defroster	Windshield

Windshield defroster

Press the function switch (2) to activate the defroster to clear fogging from the windshield.

When the defroster is activated, the icon is shown on the display screen (7).

Press the function switch (3) to cancel the defroster and return to the blower mode.

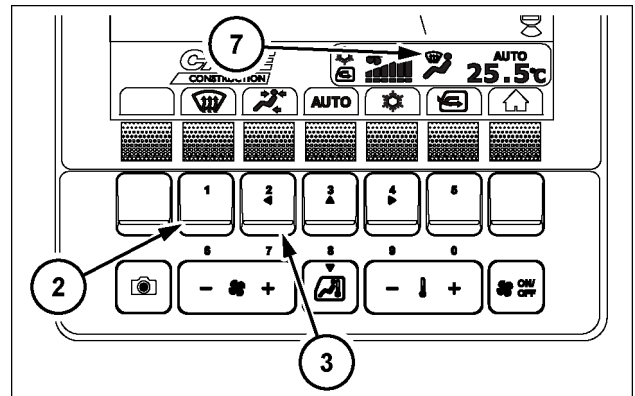

SMIL21CEX4309AA 8

Air conditioning

NOTE: When using the air conditioning, it is essential for all the operator's compartment windows, the windshield and the cab door to be kept closed. The air vents must be kept in open position.

The air conditioning can be used in two different ways: manual or automatic air conditioning.

Manual: press the air conditioner mode switch (12) or use the function switch (5) in air conditioner operation mode to turn ON or OFF the air conditioner. When the air conditioner is operating, its operating state is displayed on the display screen (7). For manual operation, use function switches (3), (6), (11) and (13) to adjust the air conditioner.

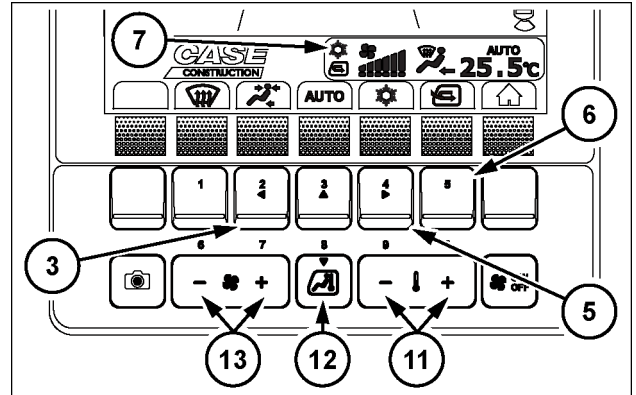

SMIL21CEX4310AA 9

Auto: press and hold the air conditioner mode switch (12) or press the function switch (4) in air conditioner operating mode to adjust the air flow and air flow direction or turn the air conditioner ON or OFF automatically. "AUTO" is shown on the display screen (7). Even when in auto mode, the air conditioner can be adjusted with function switches (3), (5) and (13). When you do so, the auto mode is canceled and the "AUTO" on the display screen (7) disappears.

NOTE: For the air conditioner system to operate correctly and function adequately, it needs to be operated at least once a week, even for a short period of time.

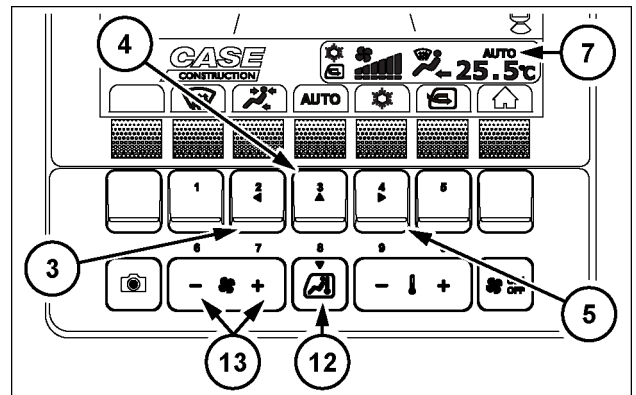

SMIL21CEX4311AA 10

Radio

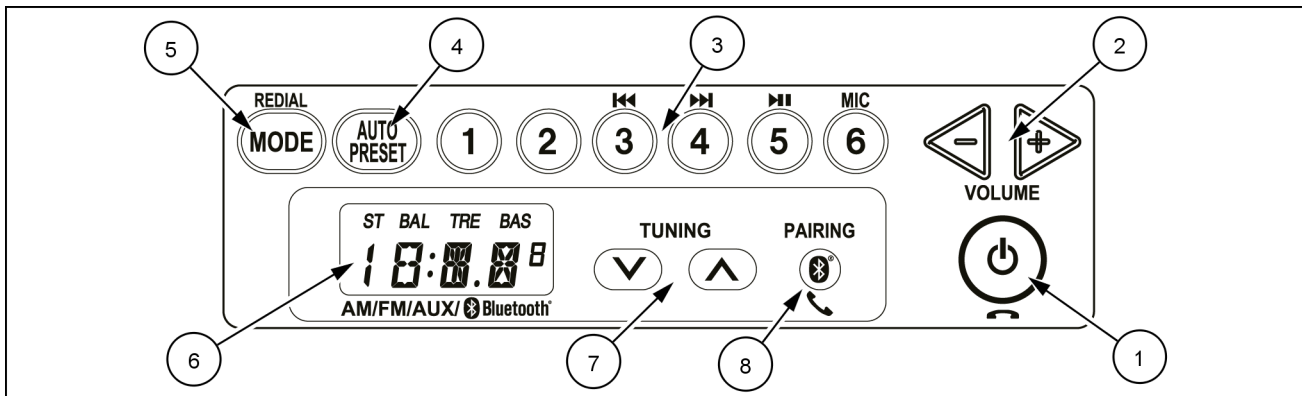

SMIL22CEX1981EA 1

NOTICE: If water gets into a speaker case or the radio, it can cause an unexpected breakdown. Do not let water get on or in them. In particular, keep the window closed when it rains and when washing the machine. Do not use benzene, paint thinner, or any other solvent to clean the display. Use a dry and soft cloth for wiping. Do not disassemble the radio.

(1) Power button and hands-free function

- Press the button to turn on the radio. The band name is displayed followed by the frequency. Press the button again to turn off the radio.
- Press this button to reject an incoming call, to cancel a redial call, to end a call, and to cancel pairing.

(2) Volume adjustment buttons

- Press the VOLUME- button to lower the volume.
- Press the VOLUME+ button to raise the volume.
- Holding down either button changes the volume continuously.

NOTE: Volume levels are stored separately for Radio (AM/FM), AUX, and Bluetooth Audio.

(3) Preset buttons and hands-free function

- One FM and one AM station can be preset for each button. To preset a station, select its frequency, then hold down the desired preset button.
- The preset button 6 allows to turn off the microphone function.

NOTE: The OFF setting of the microphone function is not retained and is canceled every time.

(4) AUTO PRESET button

- Keep pressed the AUTO PRESET button to memorize the receivable broadcast stations to the preset buttons 1 through 6.

(5) MODE button and REDIAL function

- Press the MODE button to switch the band between AM, FM, AUX, BT.
- Regardless of the current band, if you hold down the MODE button, RE is displayed for 3 s and redialing is performed. After redialing, DL flashes and ring sounds are output from the speaker. Even when the radio is OFF, during redial operation, the radio is automatically turned ON and redialing is started.

(6) Display

- Radio frequency band name and character/numeric information are displayed.

(7) TUNING buttons

- When TUNE button is held down for at least 1 s, the radio begins to search automatically for a receivable station and stops when it finds a station. Press the up button to increase the frequency. Press the down button to lower the frequency. Hold down either button to change the frequency continuously.

(8) PAIRING button and hands-free function

- Keep pressed the PAIRING button to search for a Bluetooth device and pair it.
- When receiving a call, press the button to answer.

To listen to the radio

1. Turn the starter key to ACC or ON, then press the power button to turn on the radio .
2. Press the MODE button to select either AM or FM.
3. Select a station with the six preset buttons or with the tuning buttons.
4. Adjust the volume with the volume adjustment buttons.
5. Press the power button to turn off the radio.

Manual tuning

Press the TUNING buttons once to raise or lower the reception frequency one step.

Automatic tuning

Keep pressed the TUNING buttons to raise or lower the frequency automatically.

When a receivable broadcasting station is found, searching stops at that frequency and it is received.

Preset a station

1. Press the MODE button to select AM or FM and press the TUNING buttons to select a broadcasting station.
2. Hold down the desired numbered preset button until the preset button number flashes three times on the display. The preset TUNING button is now set to the selected station.
3. Repeat steps 1 and 2 to preset other broadcasting stations.

Auto preset

- By holding down the AUTO PRESET button, frequencies with good reception are detected and registered on the preset memories 1 to 6 automatically.

NOTE: When the auto preset function is used, the registered broadcasting stations will be eliminated. To register them on the desired buttons, use the preset function.

External input

- Audio can be output from the speakers on the machine by connecting a commercially-available portable audio device.
- Always keep appropriate volume for the portable audio device.

- 1 USB port
- 2 AUX port

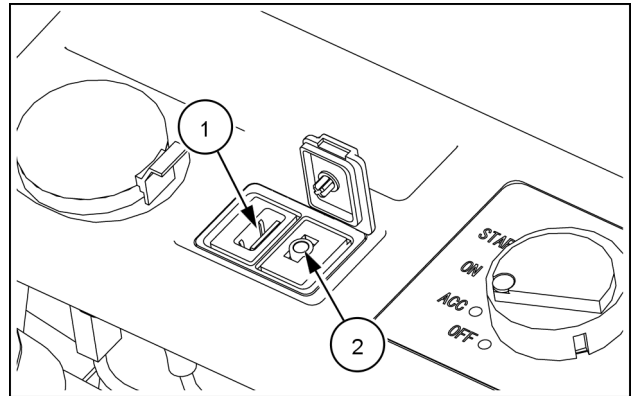

SMIL22CEX1285AA 2

AUX

- Press the MODE button to switch the audio source and check that AUX is shown on the display.
- Connect from the headphone terminal of your portable audio device using a commercially-available cord (without resistance).
- Use any commercially-available stereo mini-plug cord (D3.5) for external input terminal side. Do not use a connection cord with the wrong size or wrong shape jack.
- The volume also can be adjusted with the VOLUME buttons on the radio unit.

USB

- You can charge USB devices (cell phones or audio devices) connected to the USB.

Bluetooth

- Can be used when a Bluetooth unit is connected.
- Press the MODE button to switch the audio source and check that BT is shown on the display.
- To use the Bluetooth function, perform pairing of the devices to be connected with a wireless connection.

Bluetooth pairing

To use Bluetooth audio devices, the devices to be connected with a wireless connection must be registered in advance. This registration is called pairing. If a device has never been paired, pairing must be performed.

1. Keep pressed the PAIRING button while the unit is turned on to shift the unit into pairing mode.
2. During pairing, the display will alternately show BR- and **** (**** is the last four digits of the radio serial number). The unit will be in a state of waiting for pairing, so please search and pair from a device you want to connect wirelessly, such as a mobile phone or portable audio device.

NOTE: If you search for the radio you are pairing with, you will find two types of devices, BR-XXXX and BRXXXX-LE. Choose BR-XXXX.

3. When the pairing is completed successfully, P_o appears on the display.

NOTE: If the pairing is not completed within the time limit of **180 s** or if any abnormality occurs, P_x appears on the display. If the pairing fails, retry the pairing procedure from step 1.

Use of Audio Device Connected via Bluetooth

- Press the MODE button until BT is shown on the display.

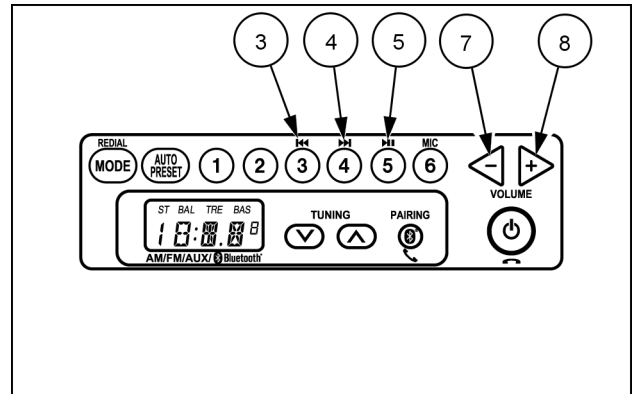

SML22CEX1286AA 3

Buttons functions

No.	Button name	Function
(3)	PRESET 3	Play previous track
(4)	PRESET 4	Play next track
(5)	PRESET 5	Play /pause the track
(7)	VOLUME-	Lower the volume. Holding down the button changes the volume continuously.
(8)	VOLUME +	Raise the volume. Holding down the button changes the volume continuously.

NOTE: Depending on the playback application, pressing PRESET 3 may return to the beginning of the track. The track number will not be displayed. Volume levels are stored separately for Radio (AM/ FM), AUX, and Bluetooth Audio.

Use of cellular phone connected via bluetooth

- When the paired cellular phone gets a call, CL will blink on the display and the speaker will output the ringtone. Even if power to this system is off, its power will turn on automatically and CL will appear when it gets a call.

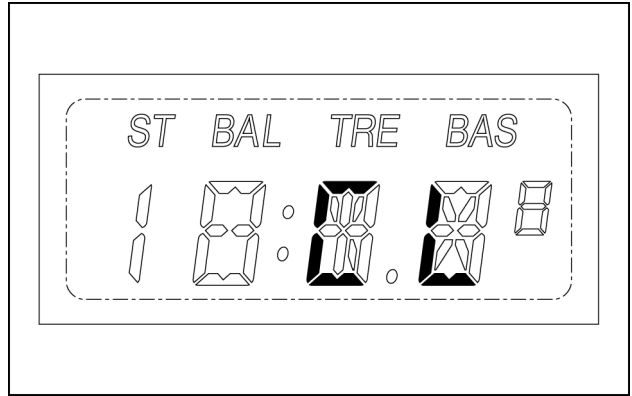

SMIL22CEX1287AA 4

- Press the PAIRING button to answer a call.
NOTE: During a call, TA appears on the display.

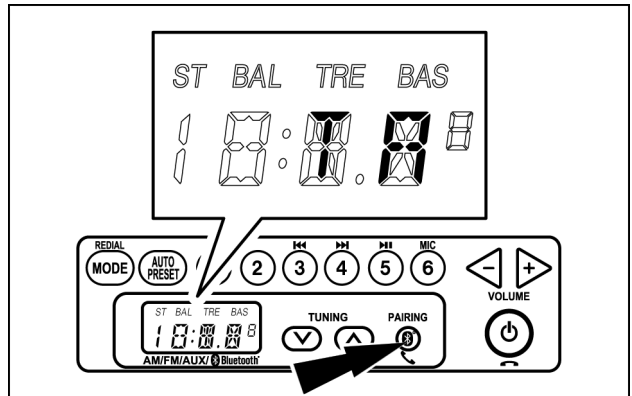

SMIL22CEX1288AA 5

- To reject a call, press the power button. The call will be interrupted, and the band will be restored to its original state.

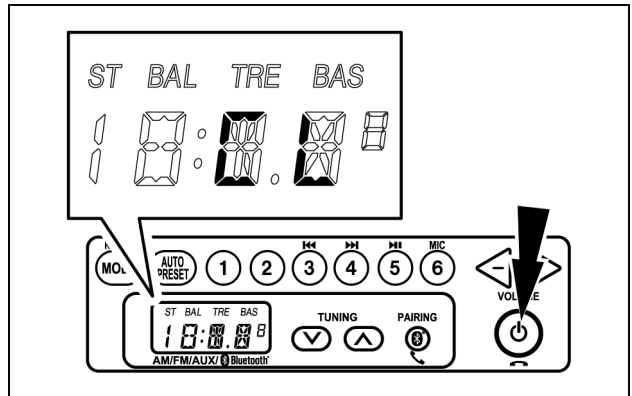

SMIL22CEX1289AA 6

- While talking, you can adjust the speaker volume by using the volume adjustment buttons (1). The preset button (6) allows you to turn on and off the microphone function.

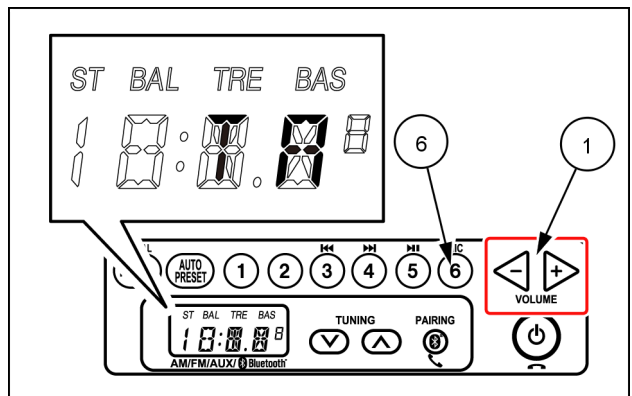

SMIL22CEX1291AA 7

- To finish talking, press the power button. The band will be restored to its original state.

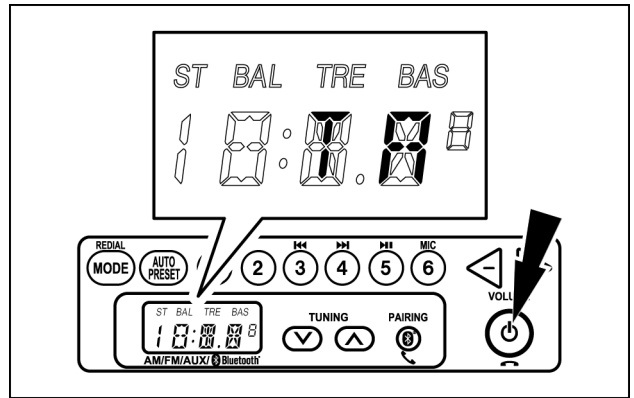

SMIL22CEX1288AA 8

- Even when the radio is turned off, by holding down the MODE button (1), RE will appear on the display for 3 s. After redialing, DL will appear, and the speaker will output the ringing tone.
- Press the power button (2) while making a redial call to cancel the call.

NOTE: Depending on the mobile phone, you may not be able to dial if the incoming call time is too short.

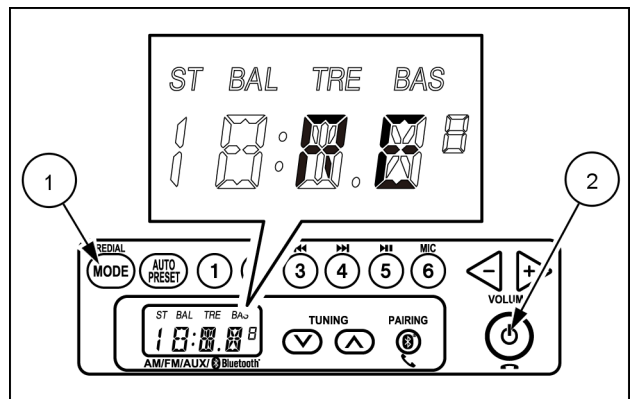

SMIL22CEX1290AA 9

Memory erasure

If the battery disconnect switch is turned to the "OFF" position or the battery connection is cut off, for example for machine service or radio removal, the memory for the preset buttons will be lost. If this happens, set the preset stations again.

Rearward controls

Fuse box

Located on the left-hand side, behind the operator's seat. The fuse boxes can be readily accessed by opening the protective cover.

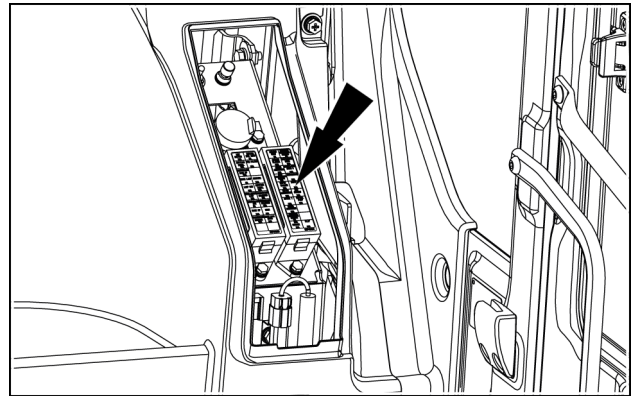

SMIL22CEX1300AA 1

Magazine rack

Located on the right-hand side, behind the operator's seat.

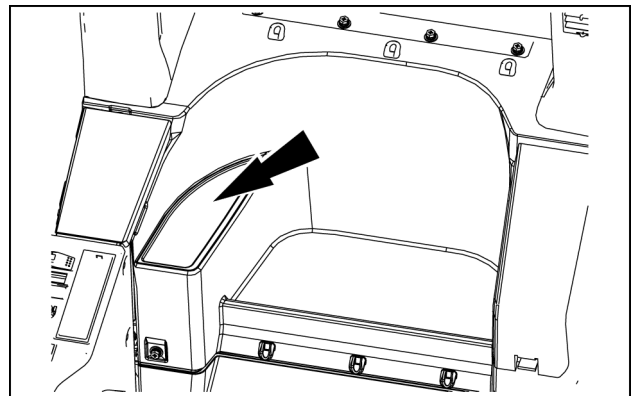

SMIL21CEX1393AA 1

Refrigerated/heated compartment

Located on the right-hand side, behind the operator's seat.

This compartment, associated with the air conditioning system, is designed to store different cold or hot products, drinks, etc.

NOTE: This is an insulated compartment. The compartment may not cool or heat depending on the conditions.

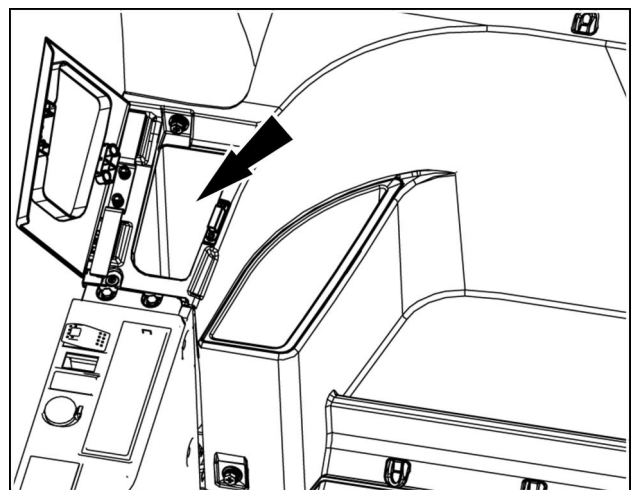

SMIL21CEX1395AA 1

Storage compartment

Located behind the operator's seat, this compartment is used to store various objects.

NOTICE: Make sure that the weight of the stored objects is less than **10 kg (22.0 lb)**.

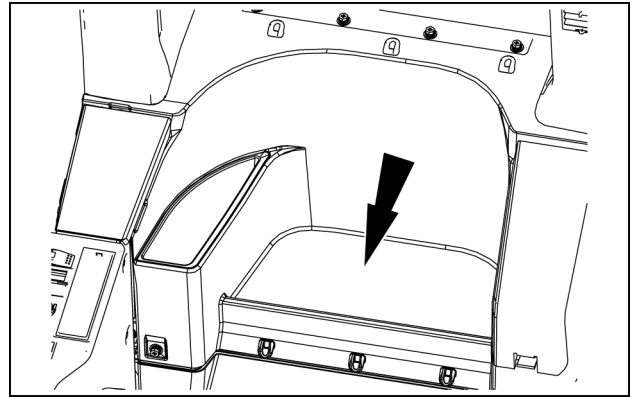

SMIL21CEX1393AA 1

Coat hanger hook

The hook is on the rear left-hand cab upright.

NOTICE: Take care not to obscure the view with clothes that are too bulky.

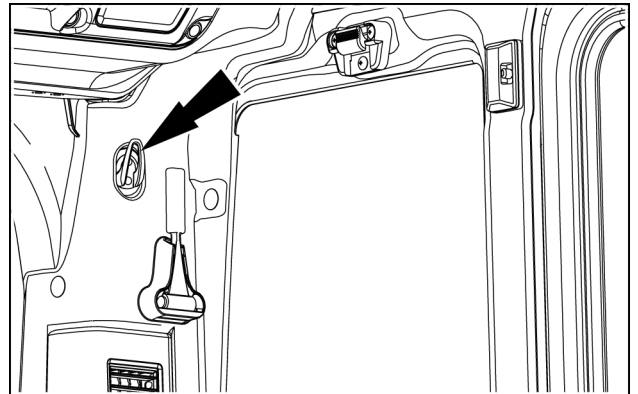

SMIL22CEX1282AA 1

Overhead controls

Roof curtain

To open the roof curtain, slide it toward the rear using the handles. To close the curtain slide it toward the front.

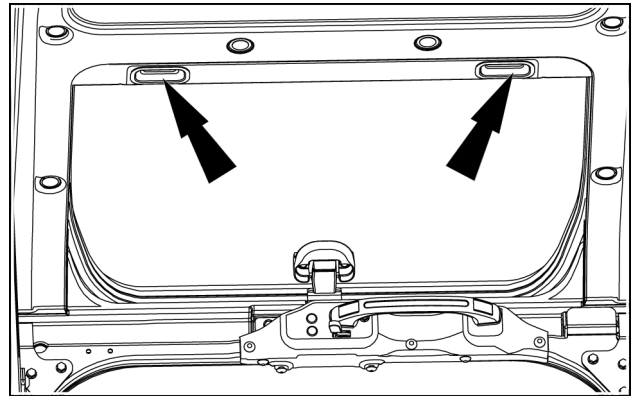

SMIL22CEX1956AA 1

Roof hatch

To open the roof hatch, operate the handle and push the handle.

To close the roof hatch, pull the handle until engagement.

NOTICE: Since roof hatch opening is assisted by two gas struts, simply follow through the closing movement without pulling or trying to hold it back.

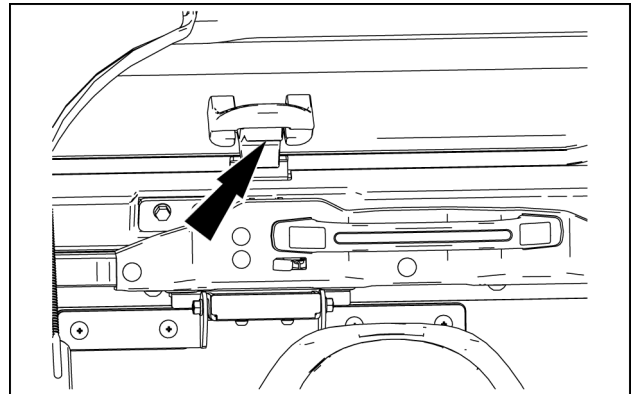

SMIL21CEX1416AA 1

Sunshield

The sun shield is fixed to the windshield and can easily be positioned as required.

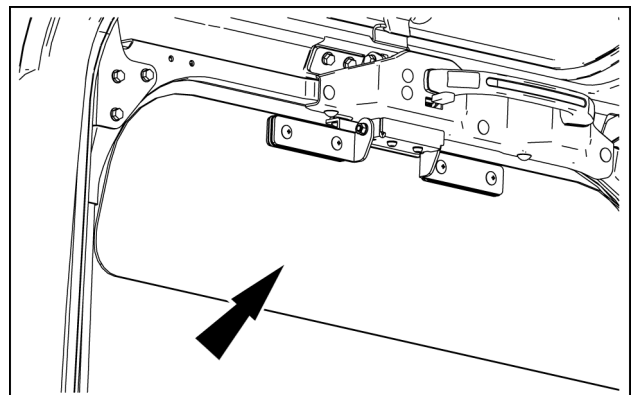

SMIL21CEX1417AA 1

Exterior controls

Cab protection (ROPS and FOPS)

⚠ DANGER

Crushing hazard!

Do not change the Roll Over Protective Structure (ROPS) in any way. Unauthorized changes such as welding, drilling, or cutting will weaken the ROPS and decrease your protection. Have an authorized dealer replace the ROPS if damage of any kind occurs. DO NOT TRY TO REPAIR THE ROPS.

Failure to comply will result in death or serious injury.

D0037A

⚠ WARNING

Roll-over hazard!

After an accident, fire, tip over, or roll over, a qualified technician MUST replace the Roll-Over Protective Structure (ROPS) before returning the machine to the field or job site operation.

Failure to comply could result in death or serious injury.

W0134A

This machine is equipped with a cab Roll-Over Protective Structure (ROPS).

NOTICE: *If the cab's ROPS (guaranteed high-strength member) is damaged, replace the cab. When replacing the cab, check the parts list for the part number of the cab appropriate for the model. If the wrong cab is mounted, the cab could be damaged when the machine rolls over, which could result in the death or serious injury to the operator or damage to the machine.*

This machine is equipped with a Cab Falling Object Protective Structure (FOPS) compliant to Level 1 as defined by ISO 10262.

Level 1 is intended for protection from small objects, e.g. small rocks, small debris and other small objects encountered in operations such as highway maintenance, landscaping and other construction site services.

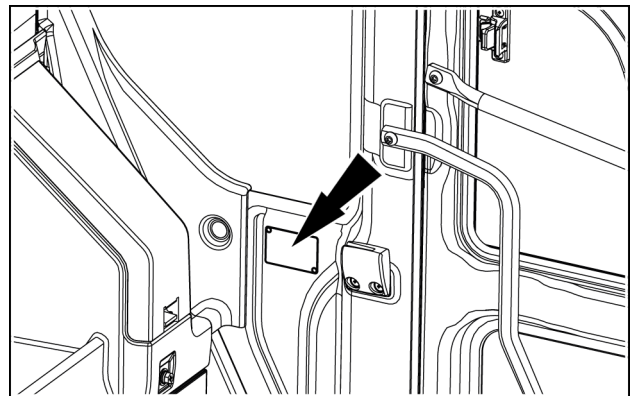

SMIL22CEX1239AA 1

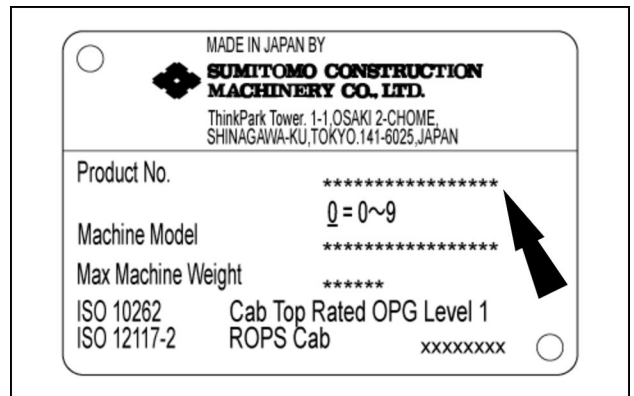

SMIL20CEX2489AA 2

In case of operations where protection from large objects, e.g. large rocks, large debris and other large objects encountered in applications such as construction and demolition a FOPS Level 2 is required and available as option.

The protective structure, the fitting supports and fastening elements on the machine are an integral part of the structure.

After a fire, corrosion or collisions, any possible damage to the cab protection structure must be carefully evaluated by specialised and qualified personnel.

In any case, all damaged parts must be replaced with genuine spare parts, in order to return the machine to its original conditions.

For an inspection of the functions of the cab's protective structures or to get parts or entire structures replaced, please consult your CASE CONSTRUCTION Dealer.

Match the part number. Do not perform modifications.

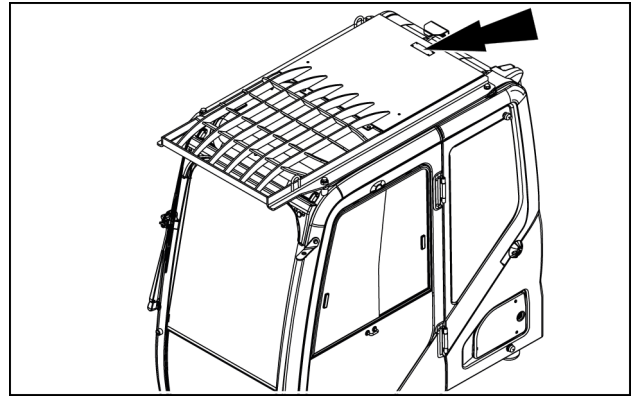

SMIL22CEX1240AA 3

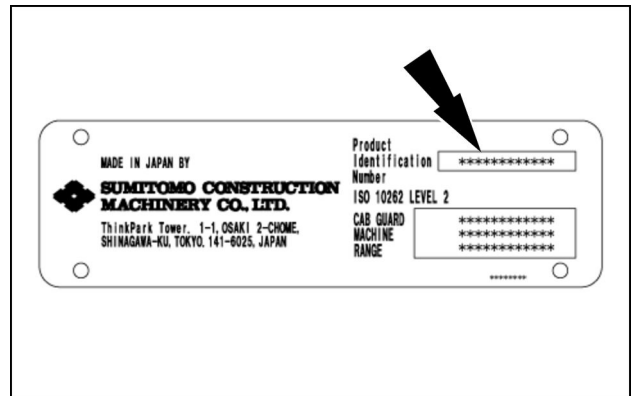

SMIL20CEX2490AA 4

Rain deflector (if equipped)

The rain deflector reduces the amount of rain on the upper part of the windshield and protects the cab lights.

NOTICE: The rain deflector is not compatible with Front Guard Protective Structure.

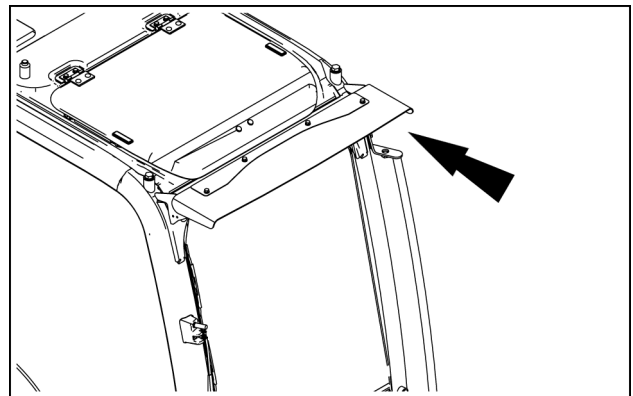

SMIL20CEX2409AA 1

Mirrors

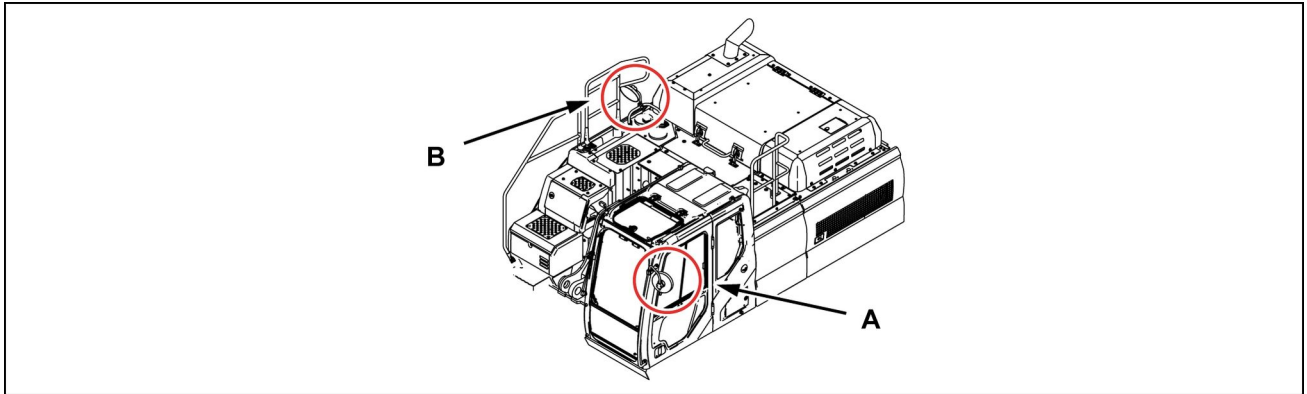

SML21CEX1397EA 1

(A) Left mirror — (B) Right-front mirror

Installation and positioning of the mirrors

⚠ WARNING

Avoid injury and/or machine damage!
Keep the mirrors clean and properly adjusted.
Failure to comply could result in death or serious injury.

W1078A

The external mirrors, along with the external cameras, ensure proper visibility around the machine during operation.

The hatched areas in the pictures indicate the zones that can be viewed by each mirror.

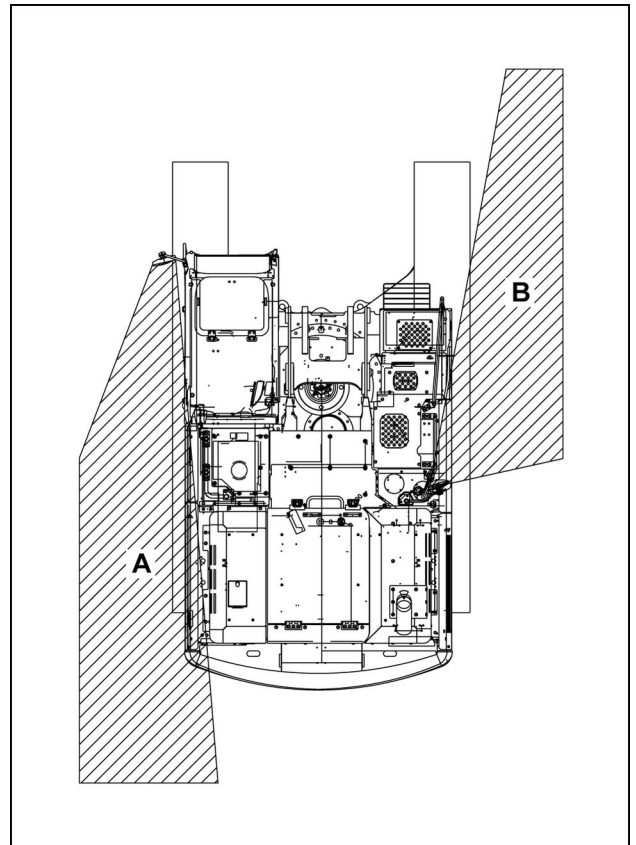

SML21CEX1398BA 2

Left mirror (A)

The mirror shall be installed as shown in the picture.

The dimension (L) is **140 mm (5.5 in)**.

The tightening torque of the bolt (1) is **71.6 – 91.2 N·m (52.8 – 67.3 lb ft)**.

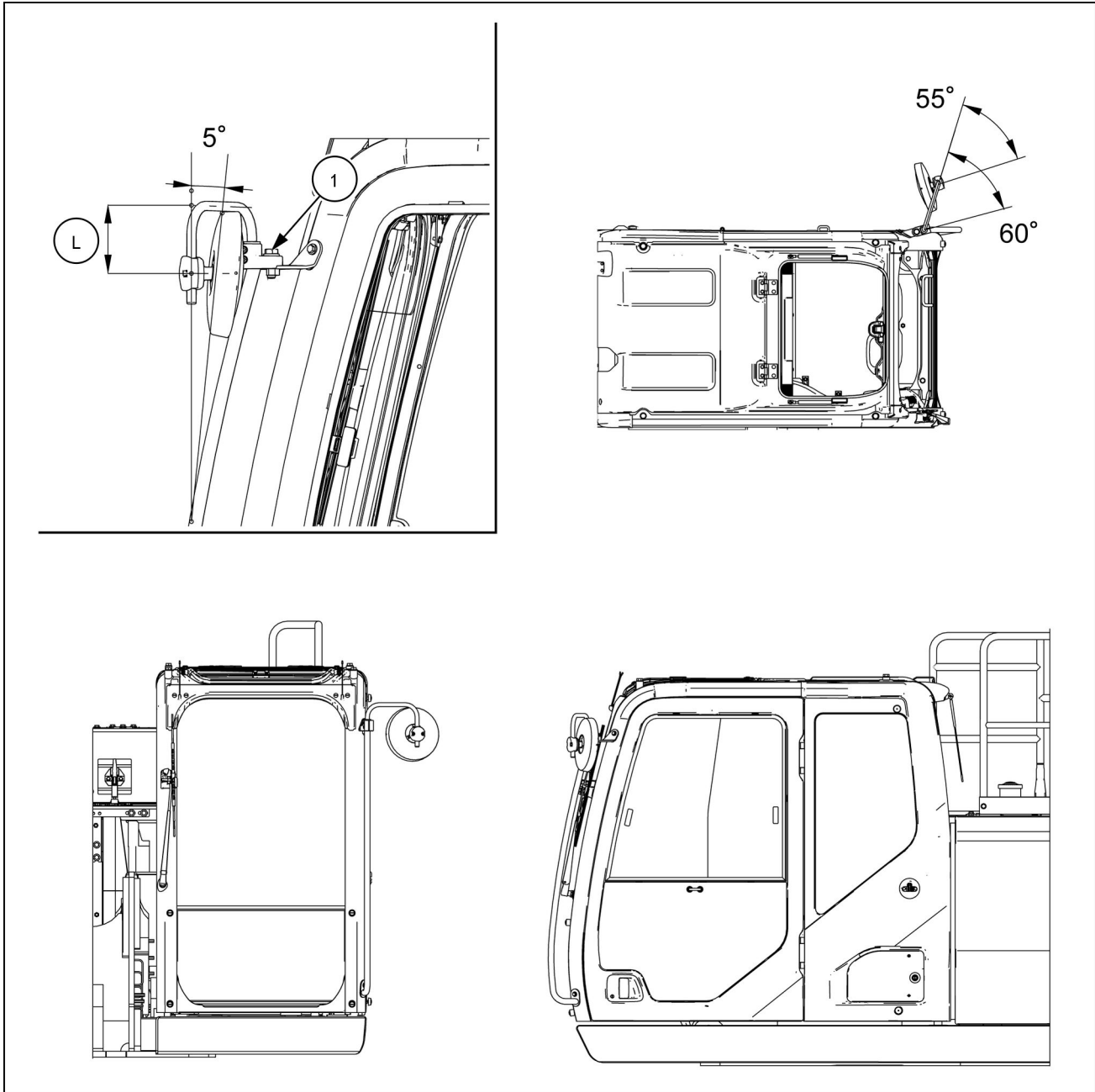

SMIL21CEX1399GB 3

The mirror shall be positioned according to the references shown in picture:

The side on the rear left of the machine shall be visible.

The area around a reference body positioned **1 m (39.4 in)** behind the machine and **1 m (39.4 in)** leftward the machine shall be visible.

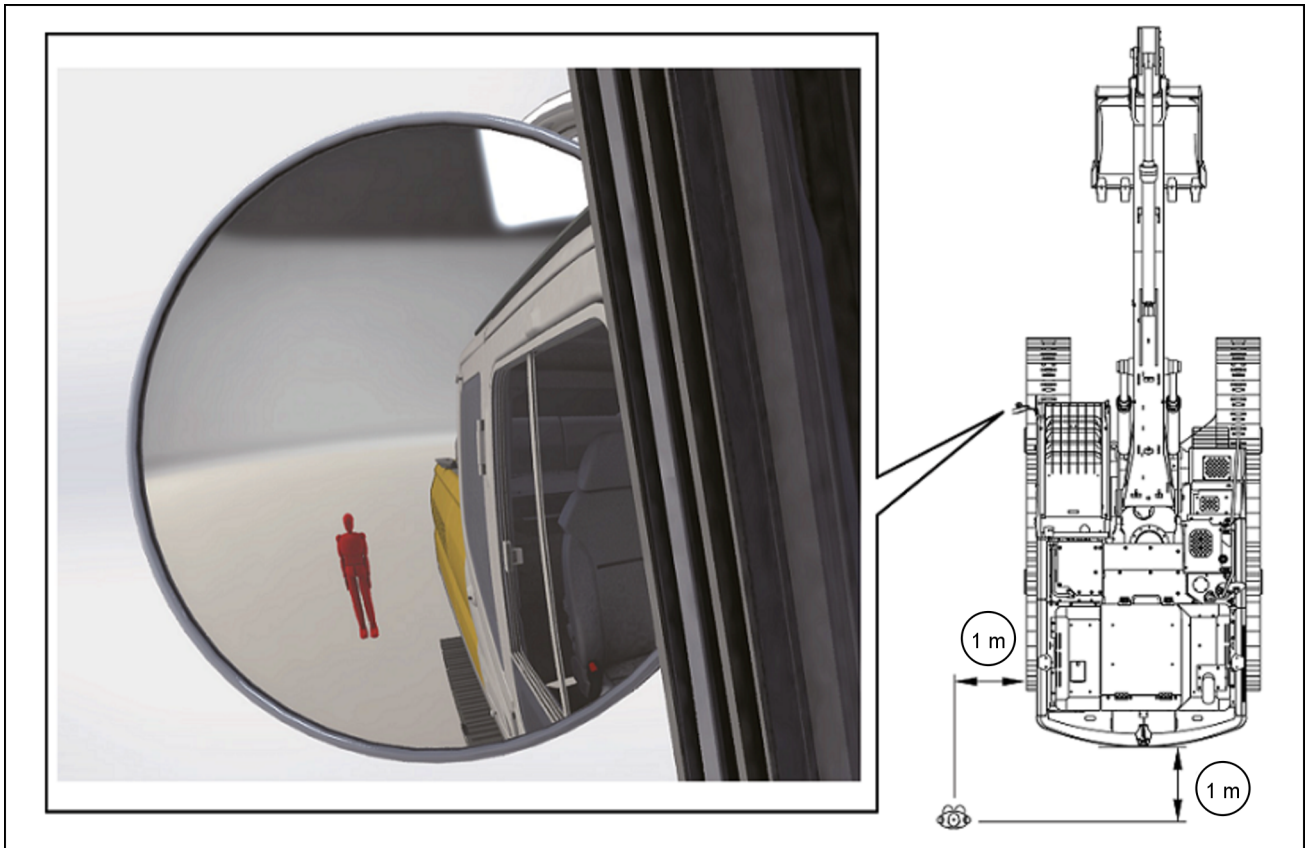

SML21CEX3140FA 4

NOTICE: After installing and positioning all the mirrors, the visibility around the machine shall be checked from the operator's seat. Set the seat into the desired position, and make sure to confirm all the reference views in the mirrors. If necessary, fine tune the positioning of the mirrors in order to ensure proper visibility around the machine.

Right-front mirror (B)

The mirror shall be installed as shown in the picture.

The dimension (L1) is 45 mm (1.8 in).

The dimension (L2) is 218.5 mm (8.6 in).

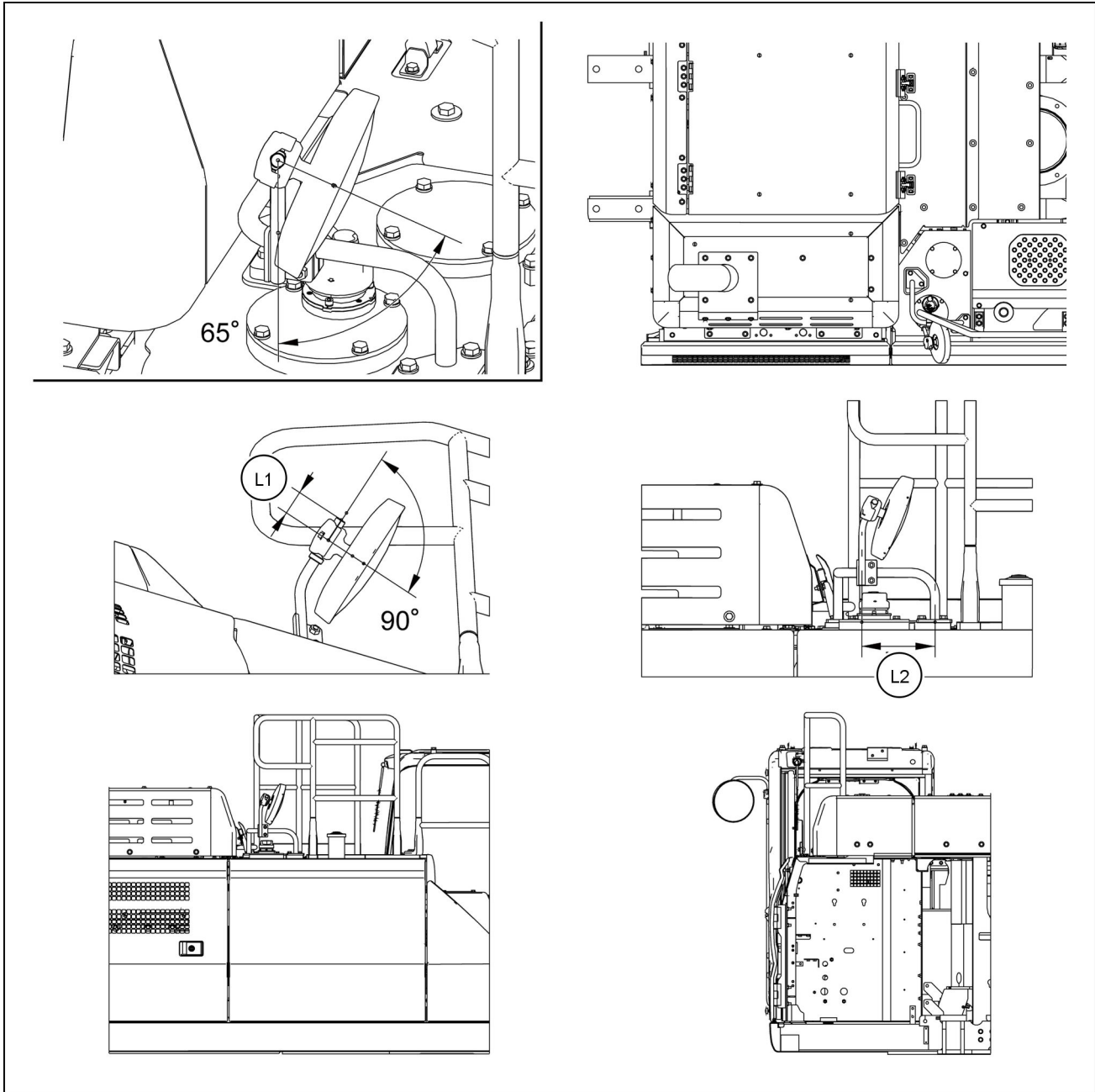

SMIL21CEX1401GA 5

The mirror shall be positioned according to the references shown in picture:

The side on the rear right of the machine shall be visible.

The area around a reference body positioned **1 m (39.4 in)** behind the machine and **1 m (39.4 in)** rightward the machine shall be visible.

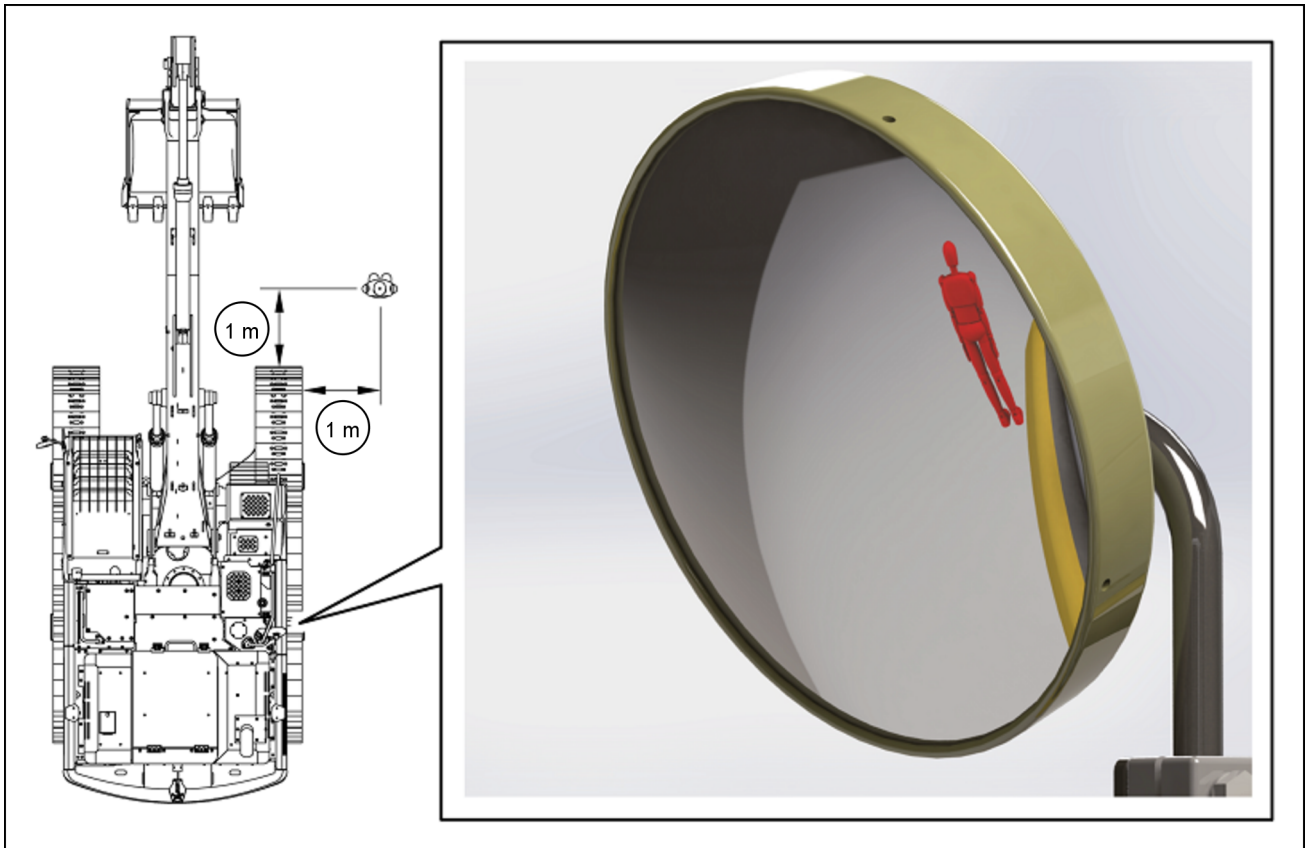

SML21CEX3141FA 6

NOTICE: After installing and positioning all the mirrors, the visibility around the machine shall be checked from the operator's seat. Set the seat into the desired position, and make sure to confirm all the reference views in the mirrors. If necessary, fine tune the positioning of the mirrors in order to ensure proper visibility around the machine.

Cameras

The external cameras, along with the external mirrors, ensure proper visibility around the machine during operation.

A rear camera (1) is installed on the counterweight. A right-side camera (2) is installed over the rear right-hand door.

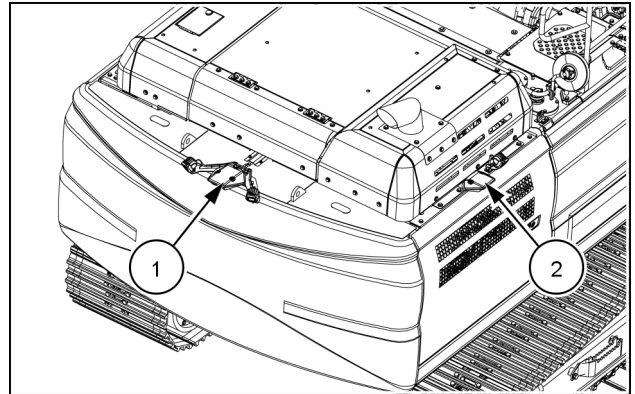

SMIL22CEX1926AA 1

NOTICE: Never operate the machine while only looking at the images on the display. Make sure to check the area around the machine by the direct view or through the mirrors.

NOTICE: If any mud, raindrops, snow, etc. are adhered to the camera lens, the images on the display are deteriorated. Wipe away dirt with a wet and soft cloth, and then wipe it with a dry and soft cloth. Make sure not to scratch the cameras.

If the cameras or the camera wirings have a failure, a warning buzzer sounds for about 5 s, the CHECK CAMERA message (1) and a DTC (3) appear, and the camera failure icon (2) is displayed. Moreover, the image of the failed camera is replaced by a grey background.

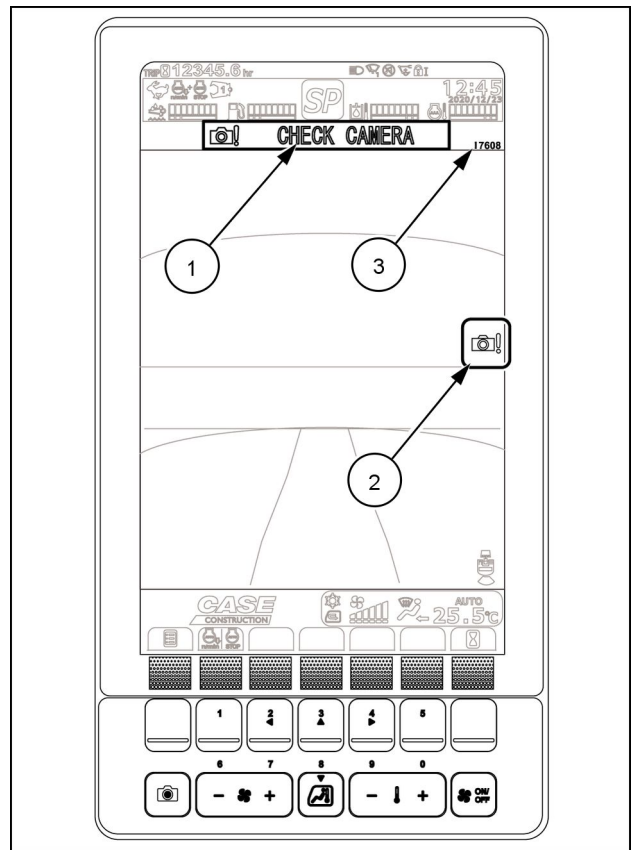

SMIL21CEX1404BA 2

Camera guidelines

Guidelines can be set up on the camera views in order to support a primary check of the area around the machine.

- (1) Guideline indicating a distance of about **1 m (39.37 in)** from the rear of the machine.
- (2) Guideline indicating a distance of about **2 m (78.74 in)** from the rear of the machine.
- (3) Guideline indicating a distance of about **3 m (118.11 in)** from the rear of the machine.
- (4) Guideline indicating a distance of about **1 m (39.37 in)** from the right-side of the machine.
- (5) Guideline indicating a distance of about **2 m (78.74 in)** from the right-side of the machine.
- (6) Guideline indicating a distance of about **3 m (118.11 in)** from the right-side of the machine.

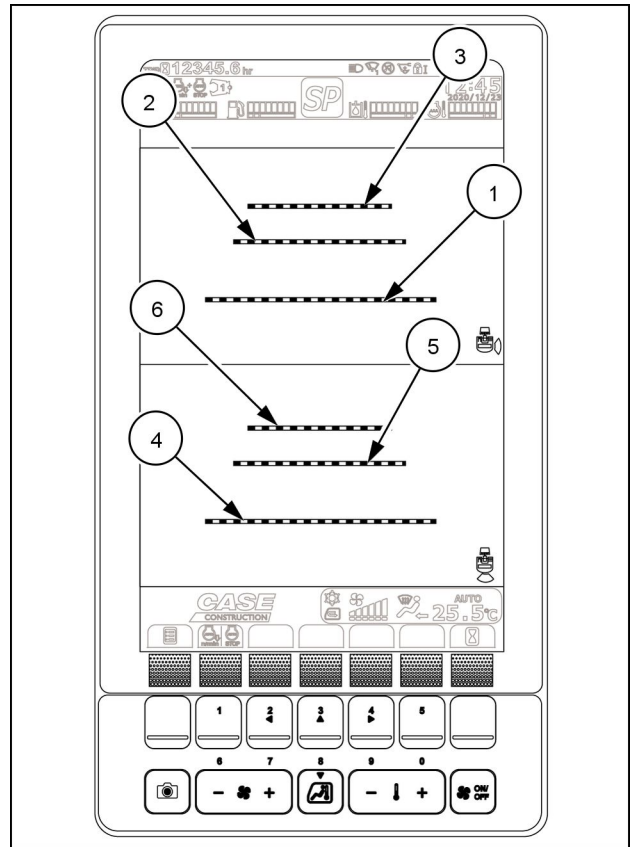

SMIL21CEX1405BA 3

Cautions for the rear view

A distance guideline targets a planar object (e.g. the ground). Therefore, if a three-dimensional object with an overhang is approaching, in particular at low distance, the distance of the overhang is not displayed properly.

The picture provides an example. The machine gets rearward, and approaches an object at a distance (**L**) of about **1 m (3.3 ft)**: on the display, the overhang (**C**) of the object appears aligned to the position (**B**) on the ground. Actually, the position (**B**) on the ground is beyond the overhang (**C**) of the object: the overhang (**C**) is rather aligned to the position (**A**) on the ground. Therefore, there is a risk of collision between the machine and the object if the machine is backed referring to the position (**B**).

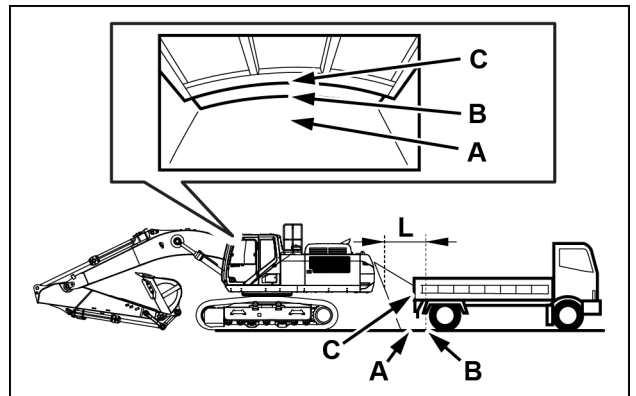

SMIL14CEX5591AA 4

Moreover, if the machine gets rearward and approaches an uphill road, an object in the position **(A)** appears aligned to the position **(C)** on the ground. Actually, the position **(C)** on the ground is beyond the position **(A)**: the position **(A)** is rather aligned to the position **(B)** on the ground. Therefore, there is a risk of collision between the machine and the object if the machine is backed referring to the position **(A)**.

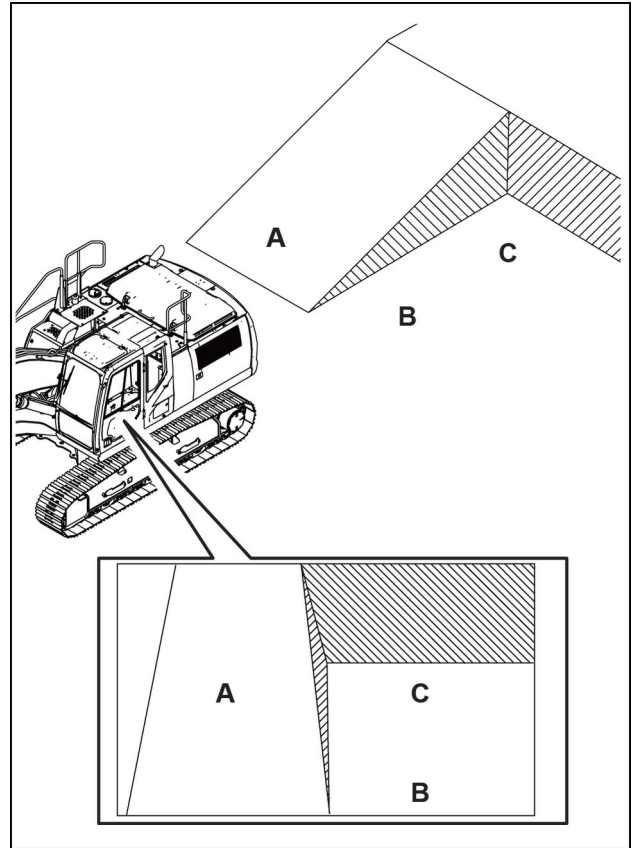

SMIL14CEX5592BA 5

Similarly, if the machine gets rearward and approaches a downhill road, an object in the position **(A)** appears aligned to the position **(C)** on the ground. Actually, the position **(C)** on the ground is beyond the position **(A)**: the position **(A)** is rather aligned to the position **(B)** on the ground. Therefore, there is a risk of collision between the machine and the object if the machine is backed referring to the position **(A)**.

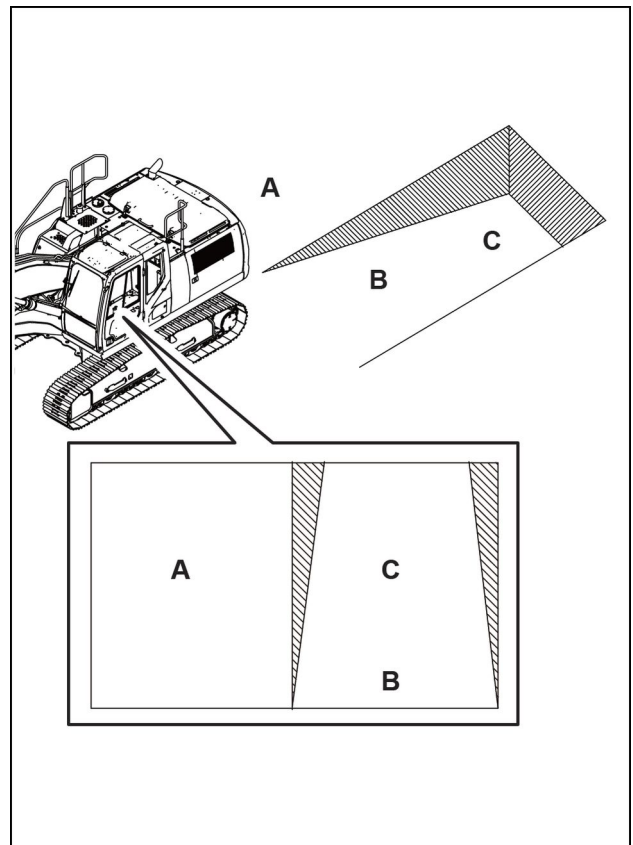

SMIL14CEX5593BA 6

3 - CONTROLS AND INSTRUMENTS

The camera system has a range where no image is displayed (blind spots):

(1) Range where no image from the rear camera is displayed.

(2) Range where no image from the right-side camera is displayed.

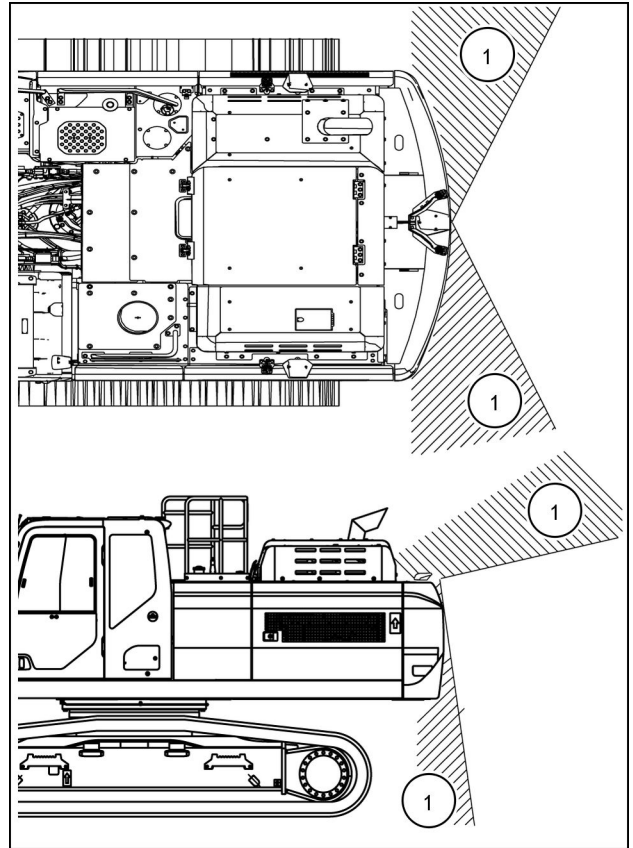

SML21CEX1407BA 7

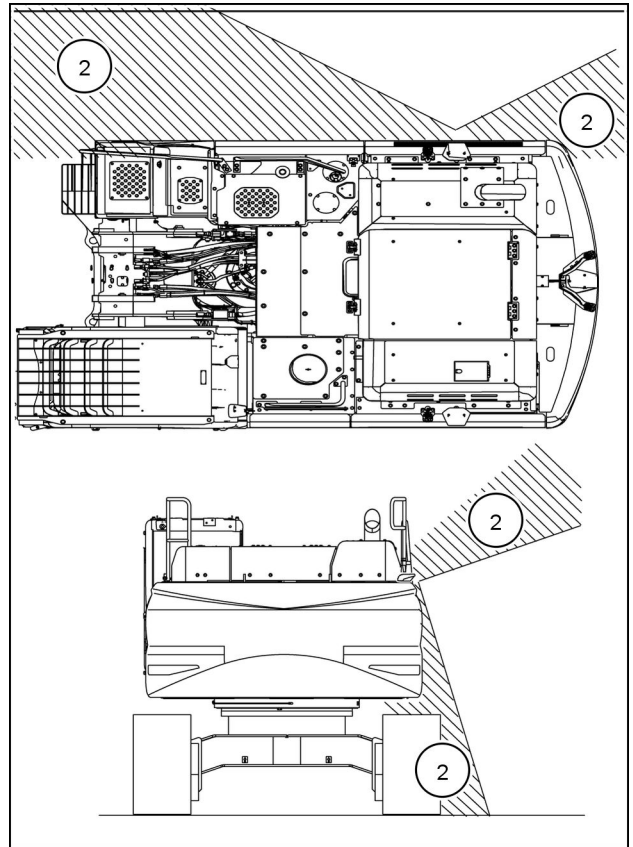

SML21CEX1418BA 8

Side doors

⚠ WARNING

Moving parts!

Make sure all entry and mechanical access doors are properly closed before operating the machine.
Failure to comply could result in death or serious injury.

W0238A

Open the side doors until they are fixed by the stays. Close the side doors unlocking the stays. Make sure to close the doors firmly. Use the starter key to lock the doors.

Rear right-hand door

The rear right-hand door allows to access the compartment including the engine oil filter, the fuel filters, the hydraulic pilot filter, the hydraulic accumulator and the hydraulic pump.

NOTE: Never leave tools inside the compartment.

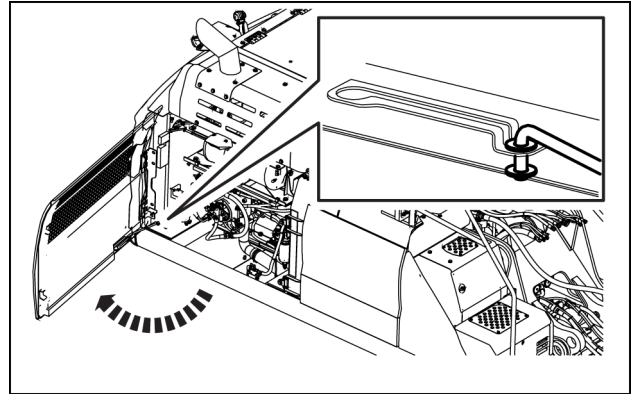

SMIL21CEX1408AA 1

Rear left-hand door

The rear left-hand door allows to access the compartment including the radiators, the oil cooler, the air conditioning dryer, the batteries, the battery disconnect switch, the reserve tank for engine coolant.

NOTE: Never leave tools inside the compartment.

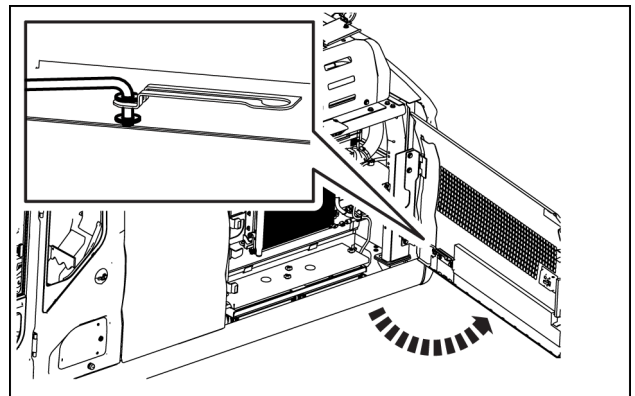

SMIL21CEX1409AA 2

Front left-hand door

The front left-hand door allows to access the compartment including the engine air cleaner and windshield washer tank.

NOTE: Never leave tools inside the compartment.

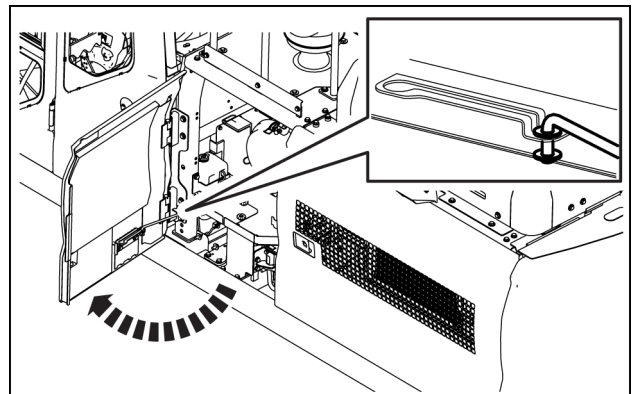

SMIL21CEX1410AA 3

Battery disconnect switch

⚠ WARNING

Electrical shock hazard!

Before you work on any part of the electrical system, disconnect the battery ground cable or turn the battery disconnect switch off (if equipped). Complete all electrical work before you reconnect the cable.

Failure to comply could result in death or serious injury.

W1393A

The battery disconnect switch is located near the batteries. It can thus be reached by opening the rear left-hand door.

The battery disconnect switch allows to cut off any power supply in the electrical system of the machine.

NOTE: When the switch is turned to OFF position, the stations stored on the radio presets and the time set for the clock will be cleared.

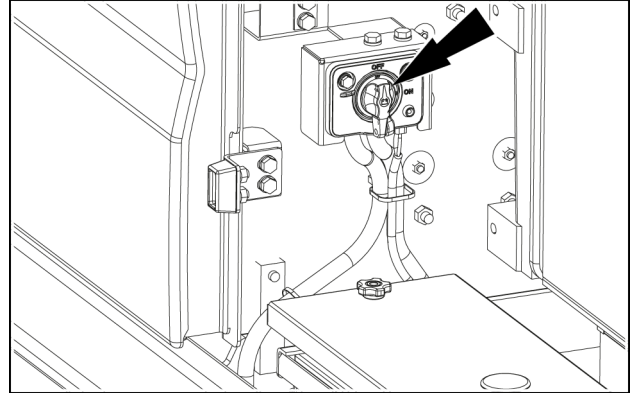

SMIL21CEX3161AA 1

The battery disconnect switch should be in ON position for normal operation.

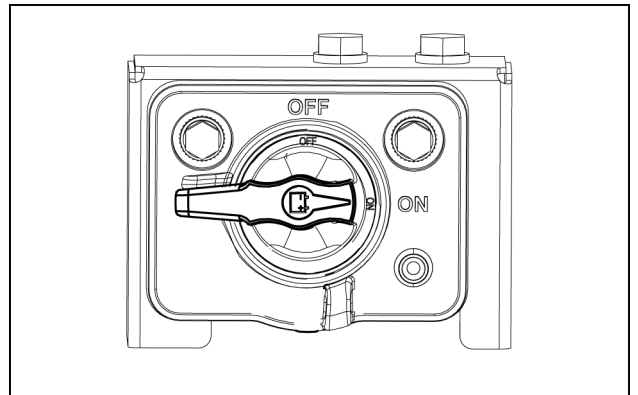

SMIL21CEX3163AA 2

The battery disconnect switch should be turned to OFF position only when the actions below must be done:

1. Service on the electrical system.
2. Batteries removal.
3. Long-term storage.

Before turning the battery disconnect switch to OFF position, make sure to park the machine and to stop the engine.

NOTICE: If the battery disconnect switch is turned to OFF position when the engine is running, the machine electrical system, the machine control system and the engine control system will be severely damaged.

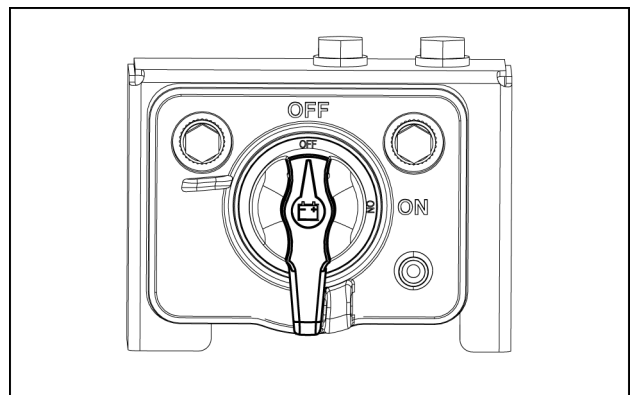

SMIL21CEX3162AA 3

The LED indicator **(1)** close to the battery disconnect switch is lit up in yellow as the main control systems are operating.

After the engine stop, the LED indicator will be active for some minutes. If the battery disconnect switch has to be turned to OFF position, wait the LED indicator **(1)** to turn off.

NOTICE: Never turn the battery disconnect switch to OFF position when the LED indicator **(1)** is lit up in yellow. The machine control system and the engine control system will be severely damaged.

NOTICE: The ATS system continues to operate for approximately **3 min** after the starter key is turned off in order to suck **DEF/AdBLUE®** back into the tank. **DEF/AdBLUE®** expands when freezing, and it will thus damage the lines of the ATS.

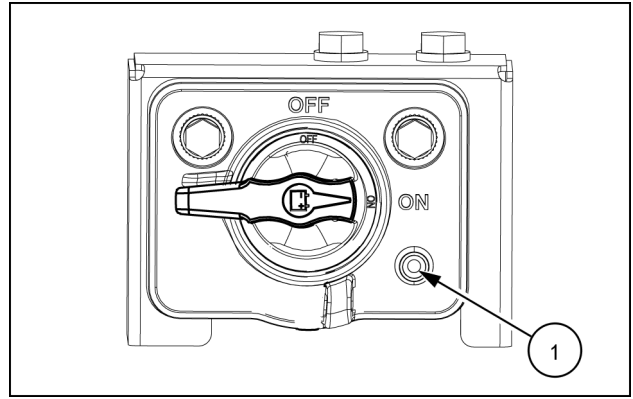

SMIL21CEX3163AA 4

Engine hood

⚠ WARNING

Unexpected machine movement!
Before you operate the machine, check that the engine hood is securely closed.
Failure to comply could result in death or serious injury.

W1486A

⚠ WARNING

Falling object hazard!
Risk of injury from FALLING ENGINE HOOD. Latch the hood in the fully open position prior to working within the engine compartment.
Failure to comply could result in death or serious injury.

W1090B

⚠ WARNING

Rotating parts!
Shut off the engine before opening the engine hood.
Failure to comply could result in death or serious injury.

W1059A

Opening

Unlock the latches with the starter key.

Disengage the latches, grab the hood handle (1), and raise the engine hood.

Follow the hood movement until the stay (2) will reach the end of the guide. The engine hood is thus fixed in the open position.

NOTICE: Do not open the engine hood during strong wind. The wind pressure on the hood surface will generate an excessive pushing force. Failing to comply may cause severe damage to the machine components, and serious injury to the operator.

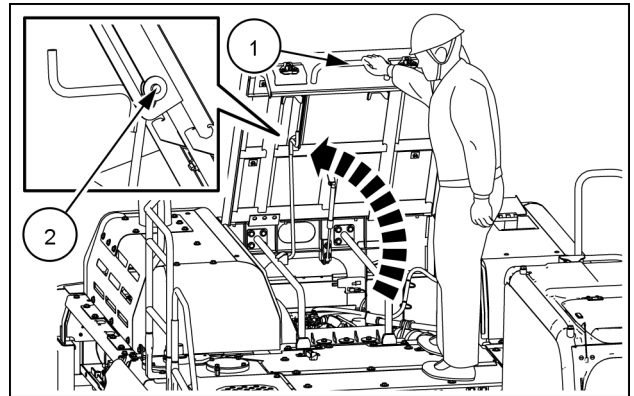

SML21CEX3116AA 1

Closing

As shown in the picture, grab the hood handle (1) with the right hand, and the stay handle (2) with the left hand. Raise a little the engine hood, and lead the stay into the guide so to unlock it. Close the engine hood.

Engage the latches firmly, and lock them with the starter key.

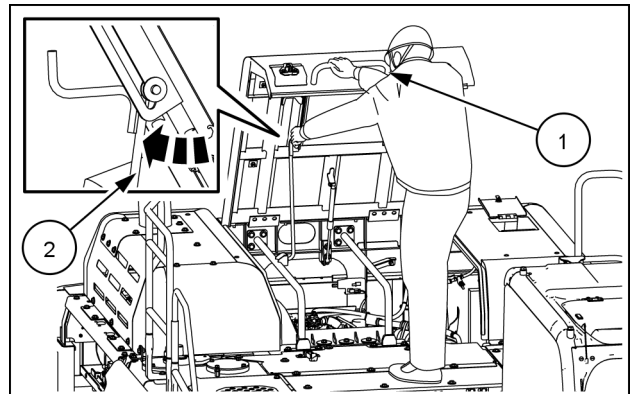

SML21CEX3117AA 2

Lower panels

⚠ WARNING

Moving parts!

**Make sure the lower panels are properly closed before driving the machine.
Failure to comply could result in death or serious injury.**

W0910A

The lower panels are located on the bottom side of the upper frame.

The lower panels give access to the following maintenance points:

- Engine oil drain plug.
- Hydraulic tank drain valve.
- Fuel tank drain valve.
- Swing reduction unit oil drain plug.
- Engine coolant drain valve.
- DEF/AdBLUE® tank drain plug.
- Turntable bearing drain plug (located under the lower frame).

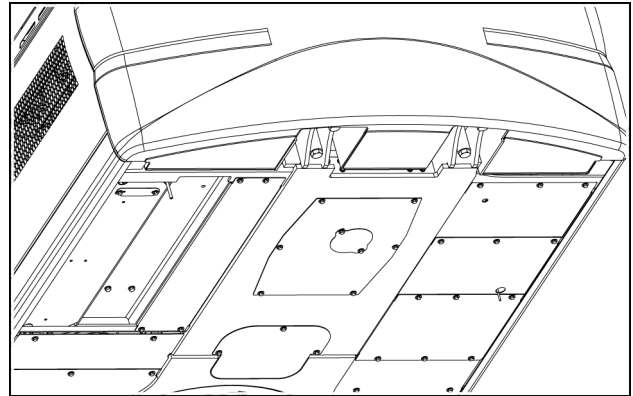

SMIL21CEX3190AA 1

Windshield washer reservoir

The windshield washer reservoir is located inside the front left-hand compartments behind the cab.

Make sure to check the reservoir level each day in order not to let the windshield washing fluid run out completely.

NOTICE: Never operate the windshield washer when the reservoir is empty. This will cause damage to the electric pump.

NOTE: In cold weather, add anti-freeze to the windshield washing fluid.

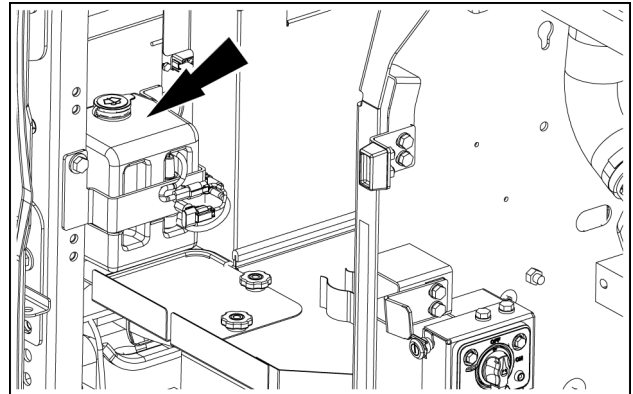

SMIL21CEX3235AA 1

Towing holes

⚠ WARNING

Misuse hazard!

Towing is a delicate maneuver that is always carried out at the risk of the user. The manufacturer's warranty does not apply to incidents or accidents that occur during towing. Where possible, carry out the repairs at the site.

Failure to comply could result in death or serious injury.

W0286A

The towing holes are located at the front and rear of the undercarriage.

The towing holes are used to tow heavy objects, up to **10 t (22046.23 lb)**.

Make sure that the slings, chains and accessories are in perfect condition and can bear the load to be moved.

NOTICE: Towing must always be done in alignment with the undercarriage.

Front towing hole.

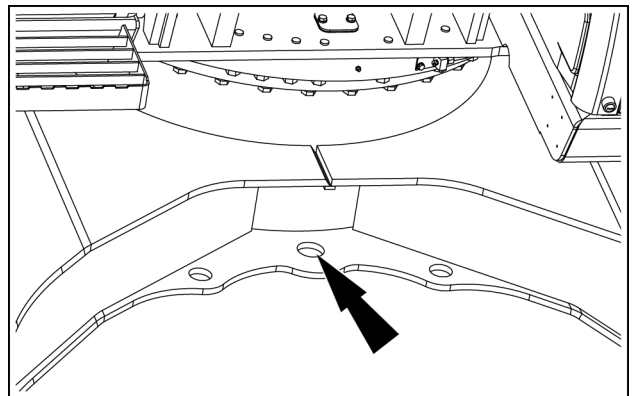

SMIL21CEX4999AA 1

Rear towing hole.

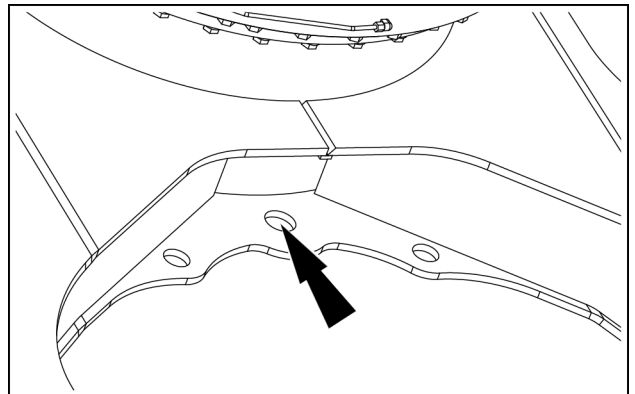

SMIL21CEX5005AA 2

Front storage box

⚠ WARNING

Moving parts!

Make sure the storage box cover is closed properly before driving the machine.
Failure to comply could result in death or serious injury.

W0288A

The storage box is located in the right front of the upper-structure. It is intended for storage of emergency tools and of small spare parts. The storage box also gives access to the fuel tank filler pump (if equipped) and to the right-hand working light.

Unlock the pushrod of the box cover with the starter key, and press the pushrod to open the box.

NOTE: The box cover is fitted with a gas strut. Open by hand to avoid damage to the machine.

Pull down the cover to close the box, and lock the pushrod of the box cover with the starter key.

NOTICE: Make sure to close and lock the box before starting machine operation. Leaving the box open can cause serious damages to the machine, and may cause serious injuries to the bystanders.

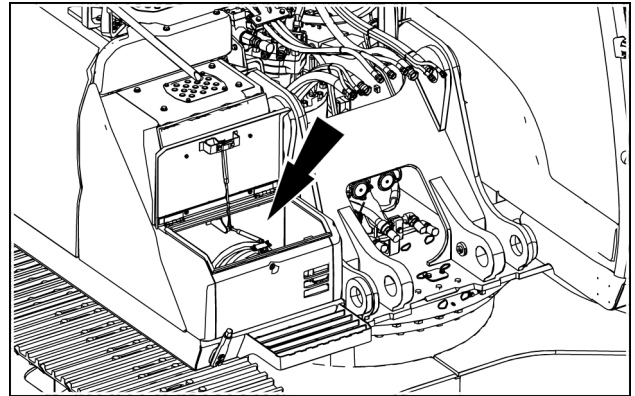

SMIL21CEX3148AA 1

Fire extinguisher

It is strongly recommended to have a fire extinguisher available and to keep it inside the front storage box.

Service specifications:

Every month: examine the fire extinguisher and make sure it is not damaged.

Every six months: have an approved specialist empty and refill the powder in the fire extinguisher.

Every year: have an approved specialist examine the fire extinguisher.

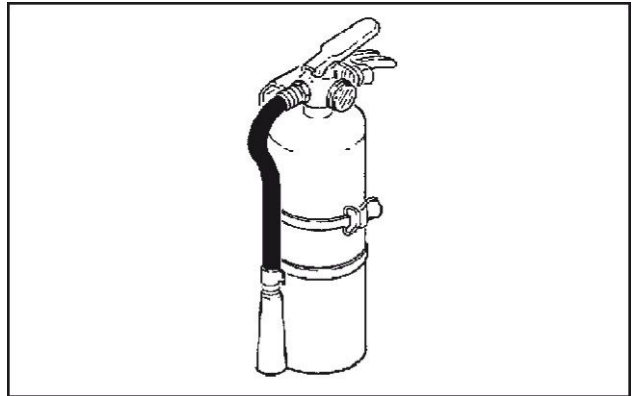

CS98M573TBP1 1

Rotary light cable

This cable is located behind the right-hand rear cab pillar. It can be used to connect a **24 V** rotary light (not supplied).

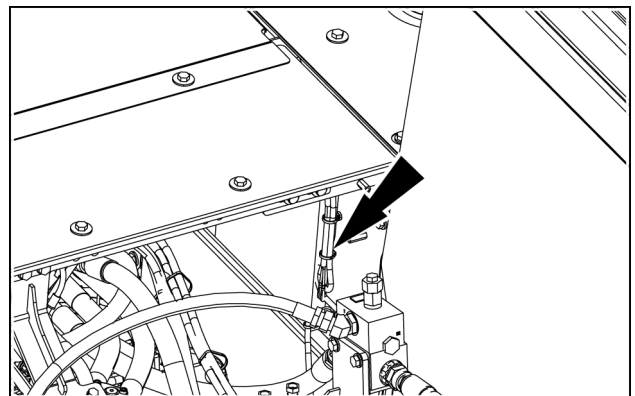

SMIL22CEX1937AA 1

Fuel tank

⚠ WARNING

Fire hazard!

When handling diesel fuel, observe the following precautions: 1. Do not smoke. 2. Never fill the tank when the engine is running. 3. Wipe up spilled fuel immediately. Failure to comply could result in death or serious injury.

W0099A

Fill the fuel tank with Ultra-Low Sulfur diesel fuel only. Refer to Chapter 6 for the detailed specifications and prescriptions about the fuel to be used.

NOTICE: Never put any moisture elimination product (water draining agent) in the fuel tank. Doing so may damage the fuel system, and thus the engine.

NOTICE: If the machine is operated in cold climate, fill the fuel tank at the end of each working day to prevent the formation of condensation.

To refill the fuel tank proceed as follows:

1. Stop the engine, and remove the starter key.
2. Get over the fuel tank. Clean the area around the fuel filler neck (1).
3. Slide the protective plate over the cap (2) of the fuel filler neck, and unlock the cap with the starter key.
4. Turn the cap (2) counterclockwise and open the filler neck.

NOTICE: Never remove the mesh filter inside the fuel filler neck. Doing so may damage the fuel system, and thus the engine.

5. Refill until the needle indicator (3) gets up from the filler neck.
6. Put the cap (2) on the filler neck. Turn the cap clockwise until it engages the stopper on the filler neck.
7. Lock the cap (2) with the starter key.

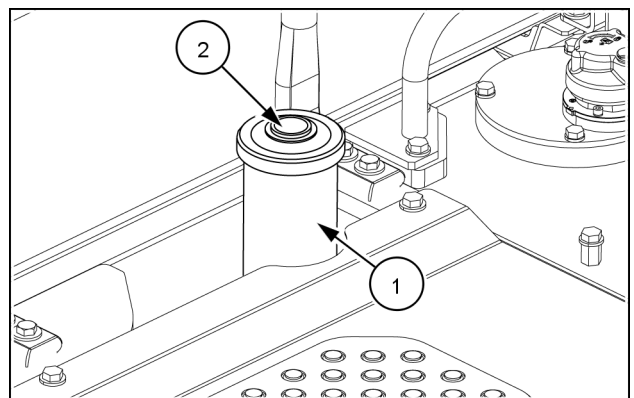

SMIL21CEX3219AA 1

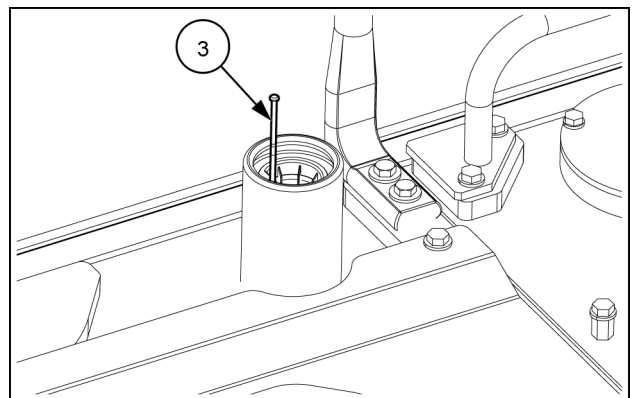

SMIL21CEX3234AA 2

Fuel tank filler pump (if equipped)

⚠ WARNING

Fire hazard!

When handling diesel fuel, observe the following precautions: 1. Do not smoke. 2. Never fill the tank when the engine is running. 3. Wipe up spilled fuel immediately. Failure to comply could result in death or serious injury.

W0099A

NOTICE: Do not put a moisture elimination product (water draining agent) in the fuel tank. It may damage the engine.

NOTICE: The fuel tank filler pump is located inside the storage box on the right front of the upperstructure. Use only for suitable fuel.

1. Park the machine on flat, horizontal ground, stop the engine and turn the starter key to ON position.
2. Take the inlet pipe out of the front storage box.

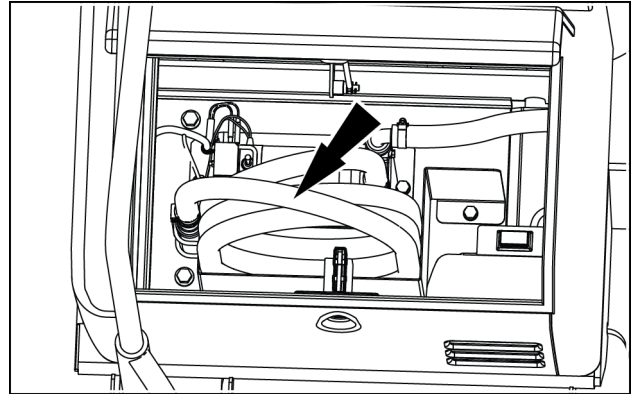

SMIL17CEX2568AA 1

3. Measure the height of the drum and place the identification clamp (1) of the suction tube at a length slightly less than that of the drum height.
4. Make sure that the end strainer of the suction tube is correctly attached and then insert the suction tube in the drum.

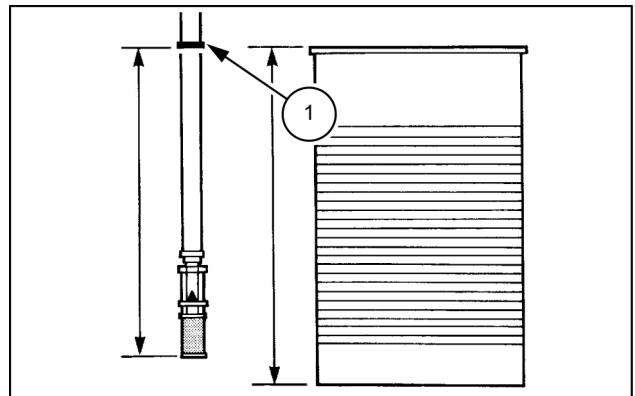

SMIL14CEX2515AB 2

5. Remove the fuel tank filler cap.

⚠ WARNING

Burn hazard!

If the filler cap remains on during the refueling process, removing the cap after refueling could cause an accident. To reduce this risk, ALWAYS remove the fuel tank filler cap before refueling with the fuel tank filling pump. Failure to comply could result in death or serious injury.

W0247A

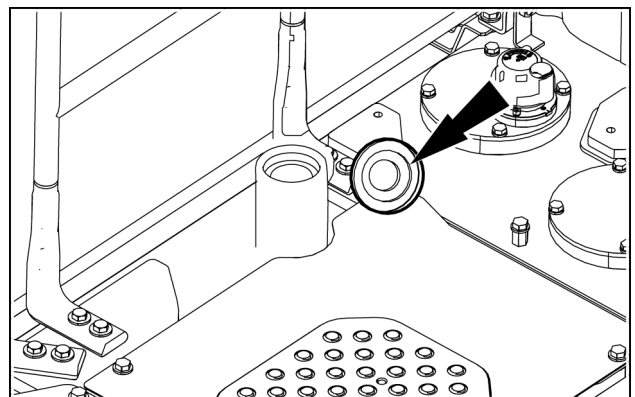

SMIL21CEX3150AA 3

6. Select the filling method using the selector switch located on the right side of the filling pump:
 - Auto mode: the pump stops filling automatically and the audible alarm sounds when the fuel tank is full.
 - Manual mode: monitor the filling from the fuel tank gauge. Stop when the fuel reaches the maximum level.

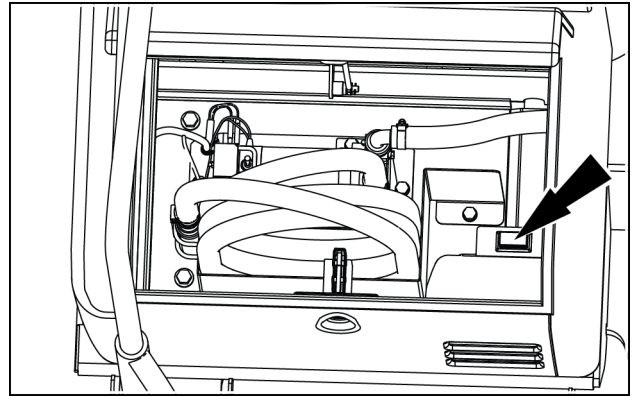

SMIL17CEX2568AA 4

7. Turn the main switch of the pump to ON position. Filling begins.
8. When the fuel tank is full, turn the main switch of the pump to OFF position. In Auto mode, the audible alarm device will cease to function.

NOTE: It is possible to stop filling at any time by turning the main switch of the pump to OFF position.

9. Run the pump for a few moments to empty the pipe outside the drum. Clean and replace the inlet pipe in the front storage box.
10. Refit the fuel tank filler cap.
11. Turn the starter key to OFF position.

NOTE: The pump is equipped with a **10 A** fuse.

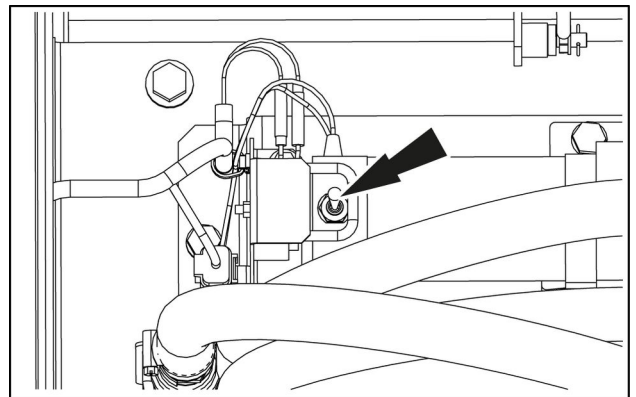

SMIL14CEX2518AA 5

After Treatment System

The after treatment system doses a NO_x (nitrogen oxides) reduction agent, **DEF/AdBLUE®**, into the exhaust gas by converting NO_x into Nitrogen and water in order to be compliant with emissions regulation.

ATS: After Treatment System

DEF: Diesel Exhaust Fluid

AdBlue®: Registered trademark of the Germany Automobile Manufacturers' Association

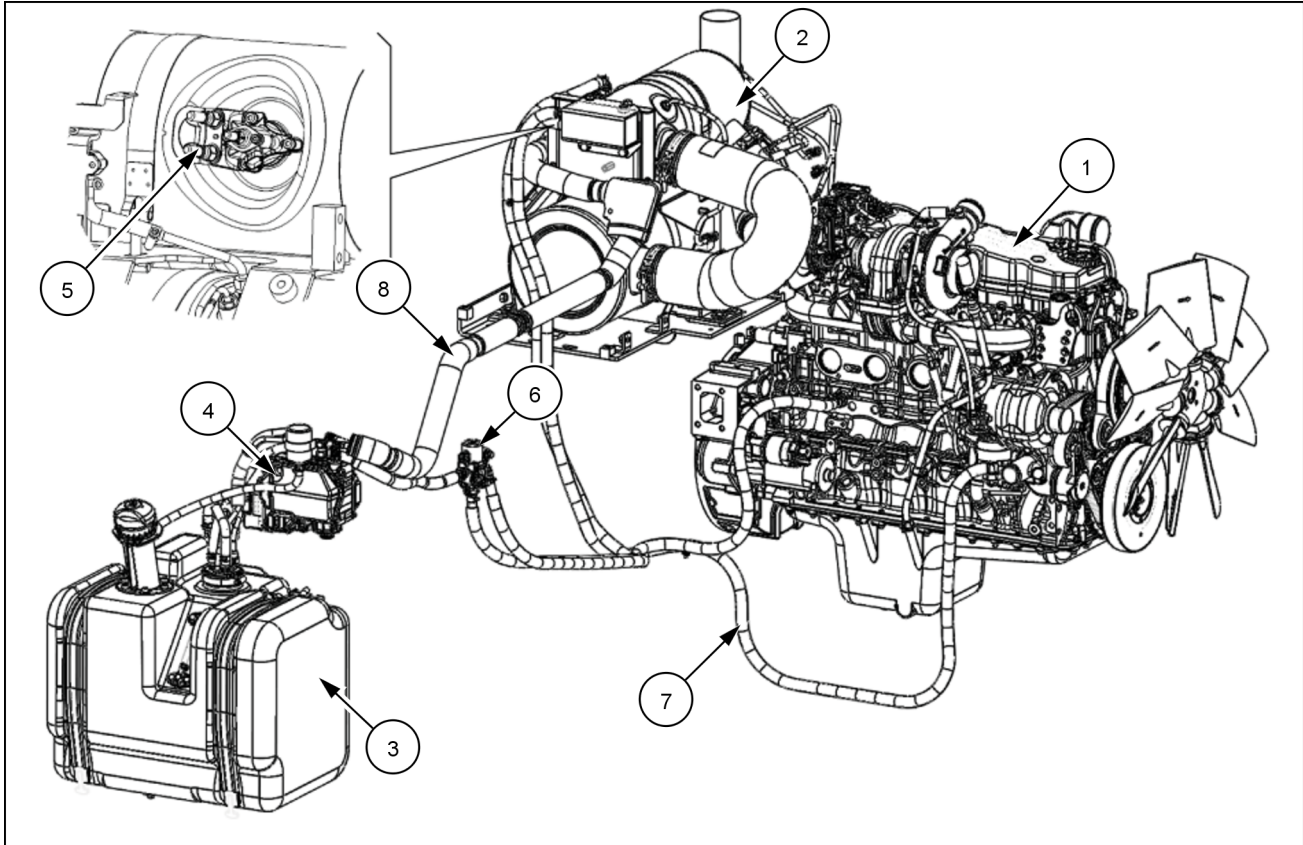

SMIL21CEX5031FB 1

- | | | |
|----------------------------|------------------|---|
| 1. Engine | 4. Supply module | 7. Coolant lines |
| 2. ATS catalyst | 5. Dosing module | 8. DEF/AdBLUE® and coolant lines |
| 3. DEF/AdBLUE® tank | 6. 3way valve | |

NOTE: Monitor the level and add **DEF/AdBLUE®** in advance, before the **DEF/AdBLUE®** level becomes lower than 10%.

NOTICE: Do not kick or hit the muffler. The oxidation catalyst in the muffler may get damaged.

NOTICE: Do not change the length or orientation of the exhaust pipe, muffler, or air cleaner line. The function of the ATS may be negatively affected. Do not remove or modify components of equipment related to the exhaust emission control system.

NOTICE: Do not touch the water released from the muffler. This water is slightly acidic due to the action of the oxidation catalyst built into the muffler. If the water from the muffler has come in contact with your skin, etc., rinse the affected area with ample water.

Refilling DEF/AdBlue®

The ATS requires the usage of **DEF/AdBlue®** fluid. The fluid is stored into a specific tank installed on the machine.

Refill **DEF/AdBlue®** only after the related gauge on the display decreases.

NOTICE: *If the tank is always filled to the FULL level, the **DEF/AdBlue®** level sensor may be diagnosed as malfunctioning.*

NOTICE: *The **DEF/AdBlue®** actual consumption is highly dependent on engine loads, engine speed, ambient conditions.*

The recommended operating practice is to check **DEF/AdBlue®** level every time the fuel tank is being refilled, and to refill **DEF/AdBlue®** when four segments of the **DEF/AdBlue®** level gauge are lit.

Use only **DEF/AdBlue®** that complies with **ISO 22241-1**. **DEF/AdBlue®** is available from CASE CONSTRUCTION dealers, authorized **DEF/AdBlue®** dealers or truck stations.

NOTICE: ***DEF/AdBlue®** is a transparent liquid with no color. Never use **DEF/AdBlue®** featuring any color as this indicates poor quality of the fluid.*

NOTICE: *Do not put any fluid other than **DEF/AdBlue®** in the **DEF/AdBlue®** tank. If anything other than **DEF/AdBlue®** is put in the tank, the quality of **DEF/AdBlue®** will drop and lead to the "CHECK AdBlue QUALITY" message. Never put diesel fuel or gasoline in the **DEF/AdBlue®** tank. Fire may occur, and the ATS will be damaged.*

It is recommended to use a **DEF/AdBlue®** filling equipment having a fill nozzle/pump with the proper length and diameter, triggered by the magnet in the tank filler neck and with overflow flow cut out. This will ensure that:

- The screen in the filler neck will not be damaged.
- Impurities are not entering the **DEF/AdBlue®** tank. The standardized **DEF/AdBlue®** nozzle matches the filler neck diameter.
- The **DEF/AdBlue®** tank is not overfilled, as the **DEF/AdBlue®** pump will stop when the **DEF/AdBlue®** tank is full.

NOTICE: *Refilling with a funnel is not recommended as this may lead to damage of the screen in the filler neck.*

Follow the steps below to add **DEF/AdBlue®**:

1. Stop the engine and remove the starter key. Wait **5 min** for **DEF/AdBlue®** back into the tank.
2. Turn the key cylinder **(2)** with the starter key to unlock the **DEF/AdBlue®** tank cover **(1)**. Turn the handle **(3)** and draw open the cover **(1)** frontward.
3. Wipe the inlet on the **DEF/AdBlue®** tank **(4)** clean of dirt, mud, and foreign objects.

NOTICE: some white powder deposits may form when **DEF/AdBlue®** adheres and dries in places such as the supply inlet. Wipe off these deposits to prevent them from entering the **DEF/AdBlue®** tank.

4. Turn the cap **(6)** counterclockwise and open the filler neck.

NOTICE: **DEF/AdBlue®** may emit an odor when the tank cap is opened. Do not attempt to smell inside the tank from the supply inlet.

5. Refill up to the F (upper limit) mark **(7)** on the level gauge **(5)**.

NOTICE: never refill **DEF/AdBlue®** over the F (upper limit) mark on the level gauge. Adequate air volume must be present in the top of the tank for proper functionality of the ATS.

NOTICE: if **DEF/AdBlue®** spills while adding, wipe off the spillage with a cloth and then rinse the area with fresh water. **DEF/AdBlue®** will cause corrosion on painted and unpainted metallic surfaces, and may distort some plastic and rubber components.

6. Put the cap **(6)** on the filler neck. Turn the cap clockwise to close the filler neck.

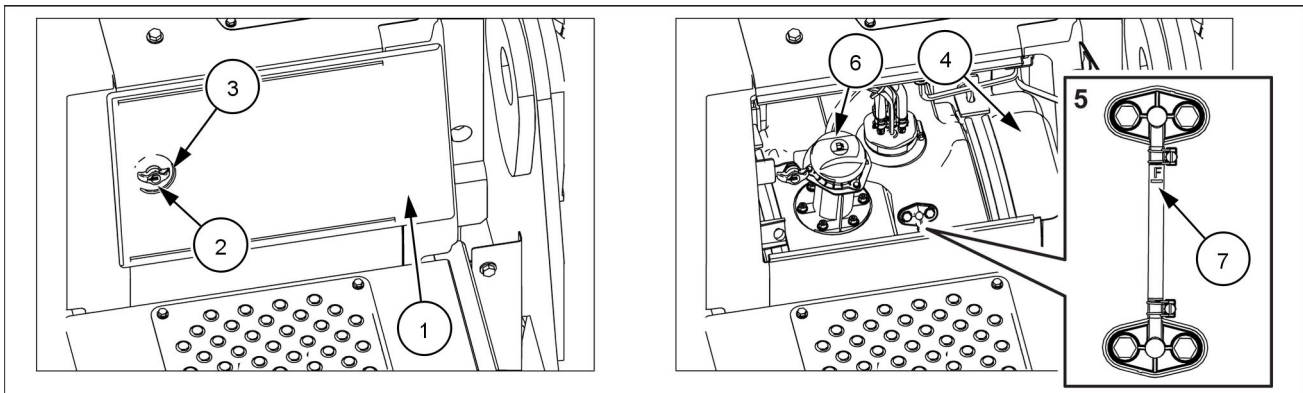

SMIL21CEX4340EA 2

1. **DEF/AdBlue®** tank cover
2. Key cylinder
3. Handle
4. **DEF/AdBlue®** tank
5. **DEF/AdBlue®** level gauge
6. **DEF/AdBlue®** cap
7. **DEF/AdBlue®** level upper limit

NOTE: The level gauge on the **DEF/AdBlue®** tank is showing just whether the tank is already full (indicated as the mark with "F") or not. As for the remaining **DEF/ADBLUE®** amount to the tank, refer to the gauge level shown on the monitor.

ATS (operation explanation)

If a problem occurs in the ATS, is displayed on the monitor a text message according to the problem type, prompting the operator to take necessary actions.

- "REFILL AdBlue" message: The **DEF/AdBLUE®** level is lower than the required level.
- "CHECK AdBlue QUALITY" message: There is a **DEF/AdBLUE®** quality abnormality.
- "CHECK ATS" message: The ATS is not working.

Operations will be restricted until necessary actions are taken. If no measures are taken, operations will be even more restricted and the engine can only run at idle. Refer to the explanation below and take necessary actions immediately.

"REFILL AdBlue" Message (DEF/AdBLUE® level is lower than required level)

When the **DEF/AdBLUE®** level becomes lower than **10%**, a warning buzzer sounds (once for **5 s**) and the machine enters the state shown in **(B)**.

The orange text message "REFILL AdBlue" is displayed and the **DEF/AdBLUE®** level gauge turns orange. This message prompts the operator to add **DEF/AdBLUE®**. Refer to the previous page.

Once the system recognizes that **DEF/AdBLUE®** is added sufficiently (**10%** or more), the orange text message "REFILL AdBlue" turns off and the **DEF/AdBLUE®** level gauge turns white.

If the **DEF/AdBLUE®** level becomes lower than **5%**, a warning buzzer sounds (5 times for **1 s** intermittently) and the machine enters the state shown in **(C)**.

The inducement icon is displayed and the orange text messages "REFILL AdBlue" and "POWER REDUCTION" are displayed alternately. The **DEF/AdBLUE®** level gauge starts flashing. In this condition, operations are restricted. The engine torque is reduced to **35%** and the engine speed is reduced to **60%** within **40 min**.

When the **DEF/AdBLUE®** level reaches **0%**, a warning buzzer sounds (continuously for **1 s** intermittently) and the machine enters the state shown in **(D)**.

The red text messages "REFILL AdBlue" and "POWER REDUCTION" are displayed alternately. The induction icon and the **DEF/AdBLUE®** level gauge turn red. In this condition, operations are even more restricted. The engine torque is reduced to **50%** within **30 min** and the engine can only run at idle.

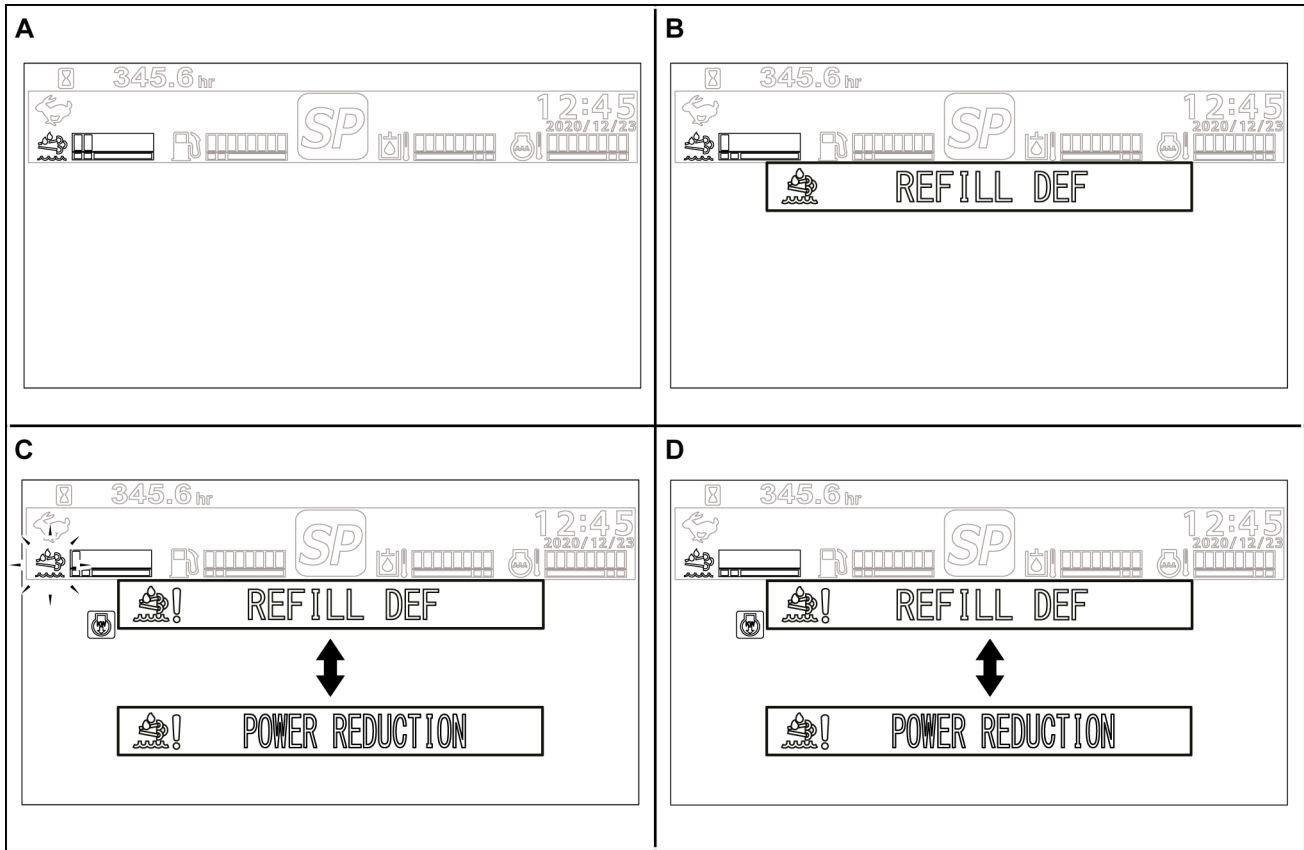

SMIL22CEX1973FA 3

- A. Normal condition
- B. Warning to the operator
- C. Moderate Inducement
- D. Severe Inducement

		A	B	C	D
DEF/AdBLUE® level		10% or more	Less than 10%	Less than 5%	0%
Engine torque		100%	100%	35%	50%
Engine speed		100%	100%	60%	Idle
Level gauge	Segments	2 or higher	1	1 (flashing)	0
	Color	White	Orange	Orange (flashing)	Red
Inducement icon		None	None	Displayed (orange)	Displayed (red)
Warning buzzer sound		None	Once for 5 s	5 times for 1 s intermittently	Continuously for 1 s intermittently
Text message		None		 ↕ 	 ↕

"CHECK AdBlue QUALITY" Message (DEF/AdBLUE® does not satisfy quality requirements)

When the ATS detects a quality abnormality of DEF/AdBLUE®, a warning buzzer sounds (once for **5 s**) and the machine enters the state shown in **(B)**.

The orange text message "CHECK AdBlue QUALITY" is displayed. This message prompts the operator to take necessary measures.

Completely drain the DEF/AdBLUE® tank. Refer to page **6-87**. Fill the tank with DEF/AdBLUE® that complies with the quality requirements.

If **50 min** have passed in the state shown in **(B)** without any measures taken, a warning buzzer sounds (5 times for **1 s** intermittently) and the machine enters the state shown in **(C)**.

The orange inducement icon is displayed and the orange text messages "CHECK AdBlue QUALITY" and "POWER REDUCTION" are displayed alternately. In this condition, operations are restricted. The engine torque is reduced to **35%** and the engine speed is reduced to **60%** within **40 min**.

If **3 h** have passed in the state shown in **(C)** without any measures taken, a warning buzzer sounds (continuously for **1 s** intermittently) and the machine enters the state shown in **(D)**.

The text messages "CHECK AdBlue QUALITY" and "POWER REDUCTION" are displayed alternately in red and the inducement icon turns red. In this condition, operations are even more restricted. The engine torque is reduced to **50%** within **30 min** and the engine can only run at idle.

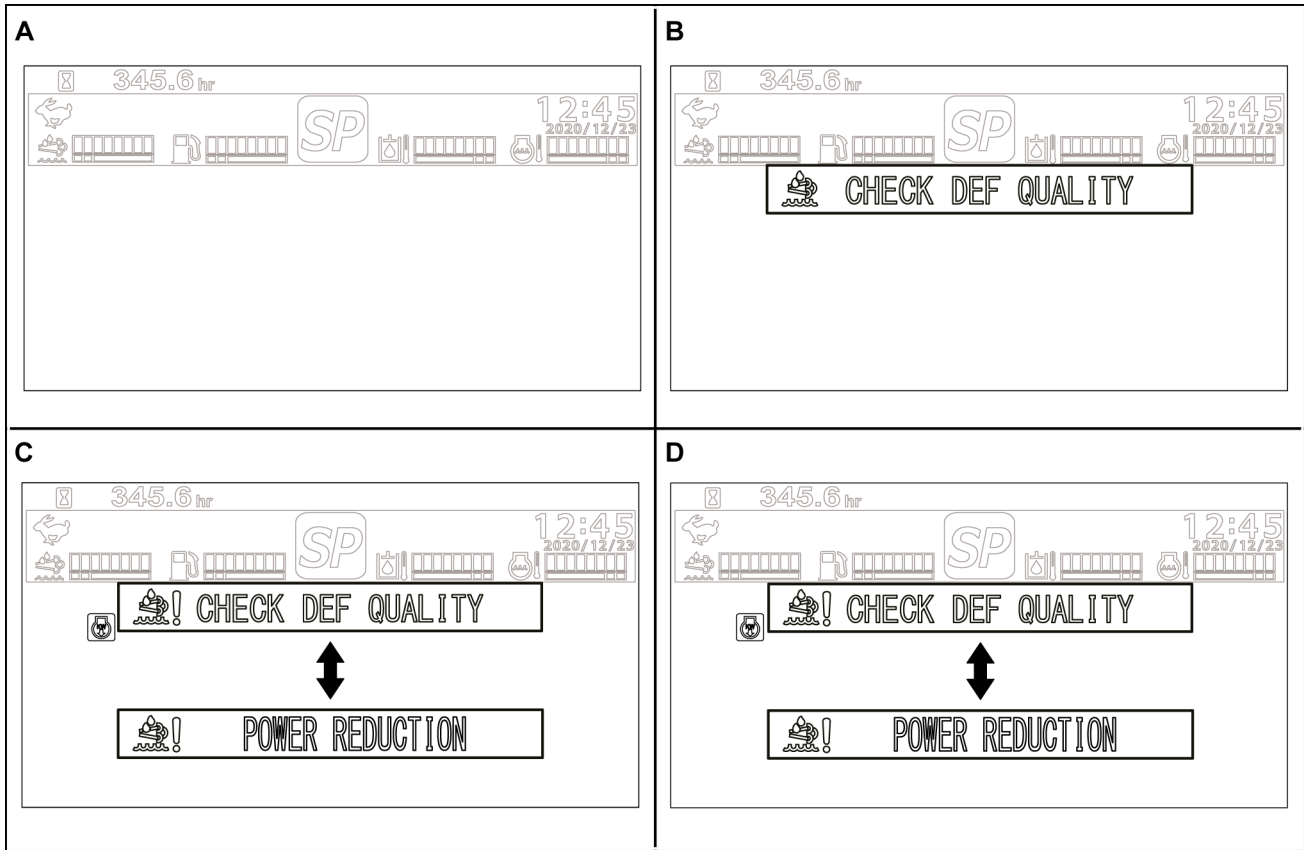

SMIL22CEX1974FA 4

- A. Normal condition
- B. Warning to the operator
- C. Moderate Inducement
- D. Severe Inducement

		A	B	C	D
DEF/AdBLUE® quality abnormality			Detected	50 min from state B	3 h from state C
Engine torque		100%	100%	35%	50%
Engine speed		100%	100%	60%	Idle
Inducement icon		None	None	Displayed (orange)	Displayed (red)
Warning buzzer sound		None	Once for 5 s	5 times for 1 s intermittently	Continuously for 1 s intermittently
Text message		None	(orange)	 ↕ (orange)	 ↕ (red)

"CHECK ATS" Message (ATS needs to be repaired)

The system detects technical failures regarding the ATS. A warning buzzer sounds (once for **5 s**) and the machine enters the state shown in **(B)**.

The orange inducement icon is displayed and the orange text messages "CHECK ATS" and "POWER REDUCTION" are displayed alternately. This message prompts the operator to take necessary measures. In this conditions, operations are restricted. The engine torque is reduced to **75%** within **25 min**. Stop the engine and contact your CASE CONSTRUCTION dealer.

If **2 h** have passed in the state shown in **(B)** without any measures taken, a warning buzzer sounds (5 times for **1 s** intermittently) and the machine enters the state shown in **(C)**.

The orange inducement icon is displayed and the orange text messages "!CHECK ATS" and "!POWER REDUCTION" are displayed alternately. In this condition, operations are restricted. The engine torque is reduced to **35%** and the engine speed is reduced to **60%** within **40 min**.



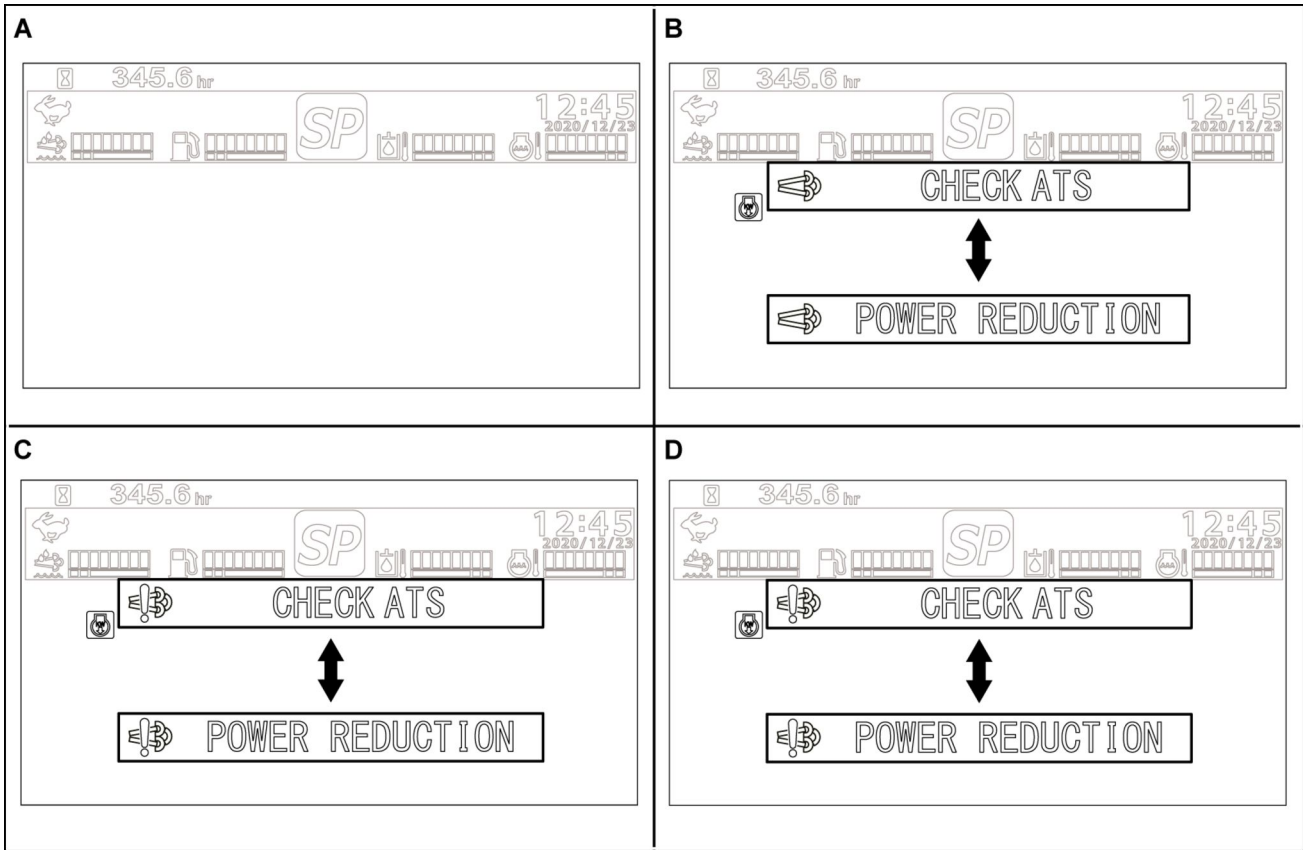

If **2 h** have passed in the state shown in **(C)** without any measures taken, a warning buzzer sounds (continuously for **1 s** intermittently) and the machine enters the state shown in **(D)**.

The red text messages "!CHECK ATS" and "!POWER REDUCTION" are displayed alternately and the inducement icon turns red. In this condition, operations are even more restricted. The engine torque is reduced to **50%** within **30 min** and the engine can only run at idle.



SMIL21CEX5499FA 5

- A. Normal condition
- B. Mild Inducement
- C. Moderate Inducement
- D. Severe Inducement

		A	B	C	D
ATS failure			Detected	2 h from state B	2 h from state C
Engine torque		100%	75%	35%	50%
Engine speed		100%	100%	60%	Idle
Inducement icon		None	Displayed (orange)	Displayed (orange)	Displayed (red)
Warning buzzer sound		None	Once for 5 s	5 times for 1 s intermittently	Continuously for 1 s intermittently
Text message		None	 (orange)	 (orange)	 (red)

ATS Cleaning

The ATS performs ATS cleaning at certain operating hour intervals to maintain its function. Comply with the following instructions in order to prevent a decreased function of the ATS and damage to the components. Also, do not turn off the engine during ATS cleaning.

- Always use the recommended engine oil.
- Always use the recommended fuel.
- Always use the recommended **DEF/AdBLUE®**.

Always place the excavator in a well-ventilated location during automatic or manual ATS cleaning.

NOTICE: Check that the engine hood is securely closed. If the engine hood is not closed, the insulation and other materials in the engine hood may melt due to the exhaust gas generated during automatic ATS cleaning, which may damage the excavator.

NOTICE: Put the machine into the transport position during manual ATS cleaning

ATS CLEANING icon

During AUTO ATS CLEANING, icon is displayed to indicate the status of the operation. According to the ATS CLEANING status, the color and display pattern will be changed.

NOTICE: Do not leave the excavator unattended during AUTO ATS CLEANING.

NOTICE: Keep away from and do not touch the ATS component, exhaust pipe, tail pipe and the exhaust gas when the engine is running, during ATS CLEANING and immediately after the ATS CLEANING process. Their temperatures may get high enough to burn people, ignite or melt materials.

NOTICE: During AUTO ATS CLEANING, make sure that the machine are away from any flammable and explosive. Those flammables such as dried grass, paper scraps and any easily burned material near the machine could cause a fire. Stop the engine while inspecting and carrying out maintenance on machine. Those activities during AUTO ATS CLEANING can result in serious personal injury.

Automatic ATS Cleaning

The excavator can be operated during automatic ATS cleaning. The load from the excavator in operation helps reduce the time for automatic ATS cleaning.

Automatic ATS cleaning is performed automatically every **70 h**. The high temperature exhaust icon **(1)** and ATS cleaning icon (green) **(2)** are displayed and an alarm sounds for about **2 s**. Automatic ATS cleaning starts when the machine meets the following conditions.

- The engine coolant temperature is higher than **70 °C (158 °F)**.
- The engine coolant temperature is lower than **100 °C (212 °F)**.

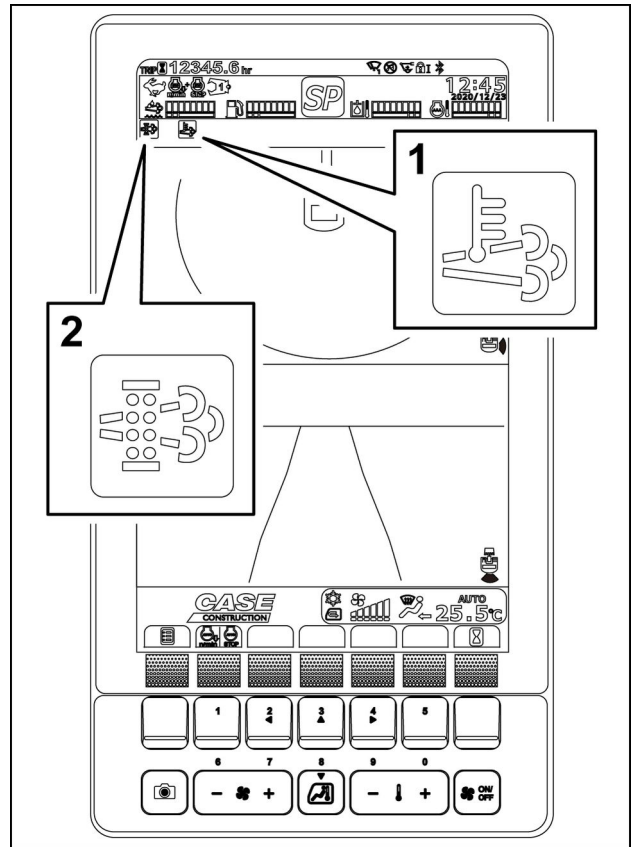

SMIL21CEX3145BA 6

Automatic ATS cleaning takes about **1.5 h**. The duration of automatic ATS cleaning varies with outside air temperature, engine coolant temperature, and engine load. When the outside air temperature and engine coolant temperature are low, automatic ATS cleaning takes longer to be completed.

Automatic ATS cleaning stops in the following situations:

- When you select the ATS CONFIGURATION in user information mode and set the "AUTO ATS CLEANING STOP" item to "ON", automatic ATS cleaning stops and automatic ATS cleaning stop icon (green) and text message "AUTO ATS CLEANING REQUIRED" are displayed and an alarm sounds for about **2 s**. Automatic ATS cleaning resumes when you set the "AUTO ATS CLEANING STOP" item to "OFF".
- When the engine coolant temperature drops below **65 °C (149 °F)**, ATS cleaning icon lights up in green and an alarm sound for about **2 s**. Automatic ATS cleaning resumes when the engine coolant temperature exceeds **70 °C (158 °F)**.
- The ATS cleaning icon starts flashing in green when the engine coolant temperature exceeds **105 °C (221 °F)**. Turn the engine throttle switch to idle speed and check the coolant. Automatic ATS cleaning resumes when the engine coolant temperature drops below **100 °C (212 °F)**.

NOTE: Do not continue operating the machine with automatic ATS cleaning stopped. If you continue operating the machine, it can damage the ATS system. Resume automatic ATS cleaning as soon as possible. When automatic ATS cleaning is stopped or remains uncompleted for **8 h**, the ATS cleaning icons flashes in orange and manual ATS cleaning is requested.

NOTICE: If you operate the excavator as usual when the ATS cleaning icon is flashing in orange, the engine or exhaust system may be damaged. Move the excavator to a well ventilated location and start manual ATS cleaning as soon as possible.

Automatic ATS Cleaning Stop

The purpose of this function is to prevent fires and explosions. The temperature of the exhaust gas produced during automatic ATS cleaning is high, therefore it is dangerous to perform automatic ATS cleaning inside a building (including tunnels) or other locations with fire and explosion risks.

To pause automatic ATS cleaning after it has started, select ATS CONFIGURATION in user information mode, then set the "AUTO ATS CLEANING STOP" item to "ON".

When it is set to ON and automatic ATS cleaning stops, the automatic ATS cleaning stop icon (green) and text message "AUTO ATS CLEANING REQUIRED" are displayed and an alarm sounds for about 2 s.

NOTE: You cannot set automatic ATS cleaning not to start. You must stop it after it has started.

NOTE: This function is only used for stopping automatic ATS cleaning that starts every 70 h. For that reason, even when this function is used, if automatic ATS cleaning has been stopped for 8 h, the system requests manual ATS cleaning. Use this function only when you need to stop automatic ATS cleaning for safety reasons.

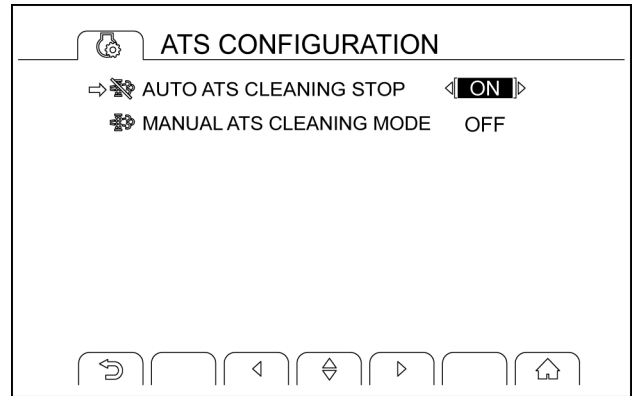

SMIL21CEX4344AA 7

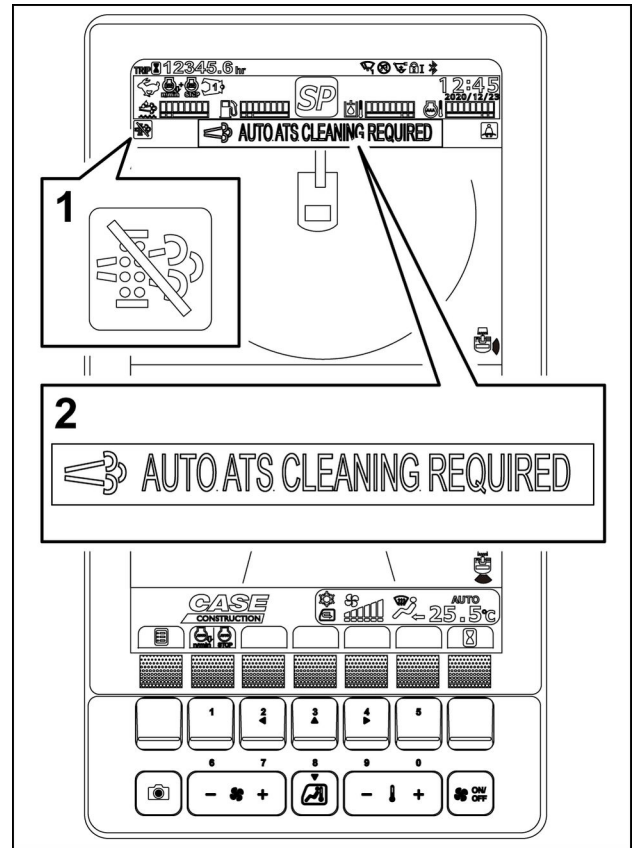

SMIL21CEX3146BA 8

Manual ATS Cleaning

To use manual ATS cleaning, select "ATS CONFIGURATION" on the menu selection screen and set the "MANUAL ATS CLEANING MODE" setting to ON.

The excavator cannot be operated during manual ATS cleaning. If manual ATS cleaning is requested during operation, the ATS cleaning icon (1) flashes in orange, an alarm sounds for about 2 s, and the text messages (2) "MANUAL ATS CLEANING REQUIRED" and "SET GATE LOCK LEVER TO CENTRAL POSITION" are displayed alternately.

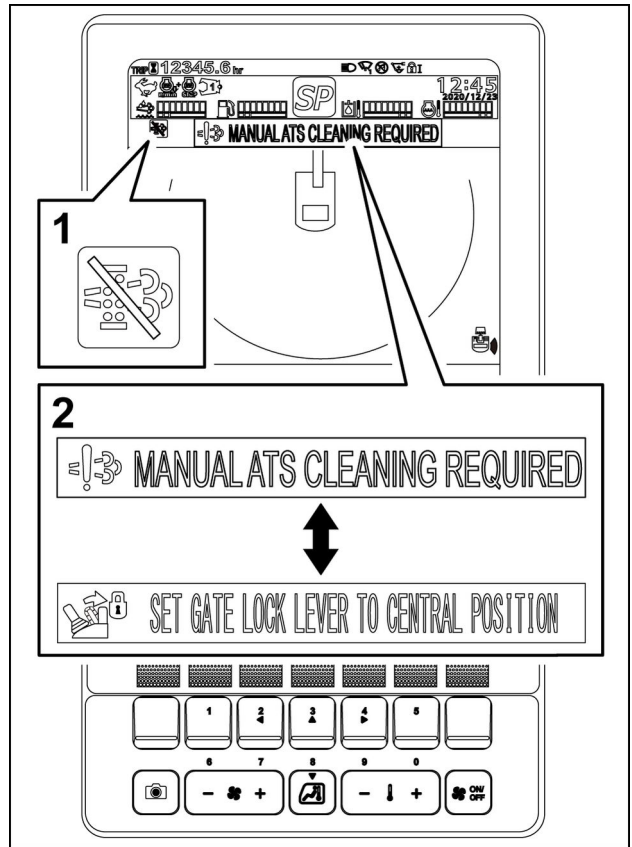

SMIL21CEX4345BA 9

If the fuel gauge (1) shows 2 segments or less, the ATS cleaning icon (2) flashes in orange and the text messages (3) "REFILL FUEL" and "MANUAL ATS CLEANING REQUIRED" are displayed alternately and manual cleaning cannot be started so that manual cleaning does not stop before it is finished due to being out of fuel. In this case, add fuel immediately.

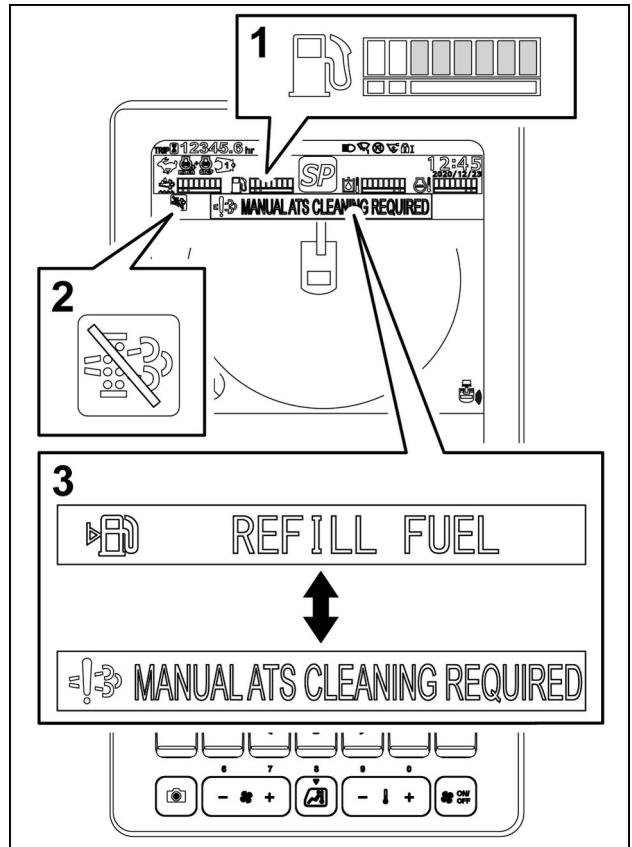

SMIL21CEX4346BA 10

Starting manual ATS cleaning

1. Move the excavator to a well ventilated location.
2. Check that the fuel gauge shows 3 segments or more, then set the gate lock lever to the center position **(1)** (with safety bar in the non-operation position).
3. Turn the engine throttle switch to idle speed.

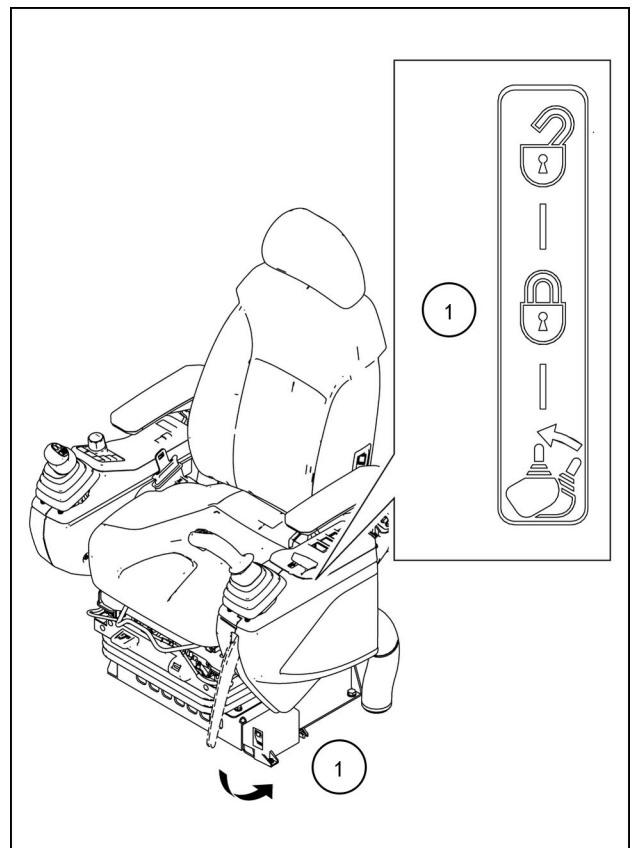

SMIL21CEX3153BA 11

4. The ATS cleaning icon **(1)** flashes in orange, an alarm sounds for about **2 s**, and the text message **(2)** "PUSH ATS CLEANING SWITCH TO ACTIVATE" is displayed. The ATS cleaning icon **(3)** is displayed on the function switch tab.
5. Press the button **(4)** underneath the icon to start manual ATS cleaning.

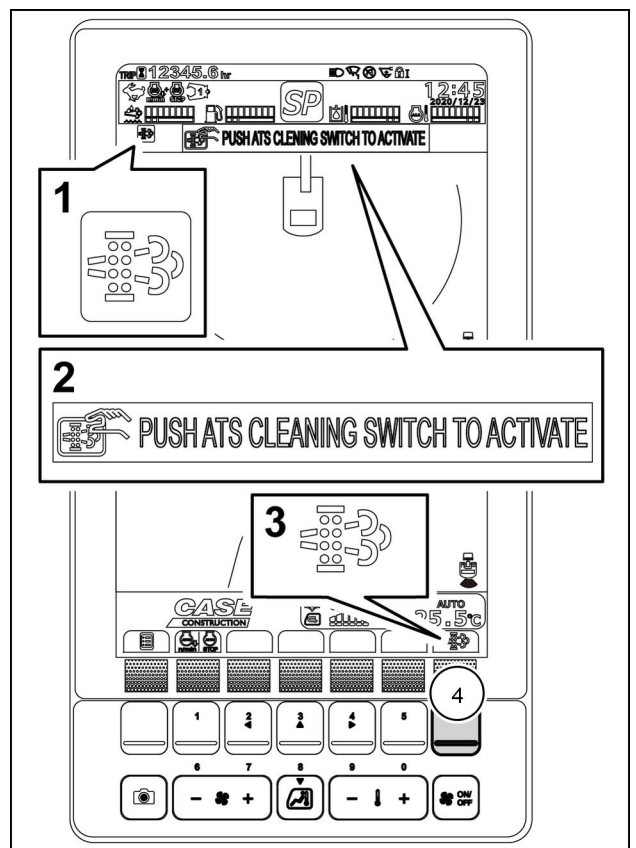

SMIL21CEX4347BA 12

When manual ATS cleaning starts, the orange ATS cleaning icon (1) and the orange high temperature exhaust icon (2) are displayed. An alarm sounds for about 2 s, and the orange text messages (3) "!DO NOT OPERATE" and "!MANUAL ATS CLEANING" are displayed alternately.

Manual ATS cleaning takes about 30 min. When manual ATS cleaning is complete, the ATS cleaning icon (1), the high temperature exhaust icon (2), and the messages (3) disappear. Manual ATS cleaning stops in the following situations. If manual ATS cleaning stops before it is finished, the ATS system needs to be cooled down. The orange text messages "!DO NOT OPERATE" and "!MANUAL ATS CLEANING CANCELLED" are displayed alternately. Do not operate the excavator until the ATS system is cooled down.

- Problems with the machine (The applicable text message is displayed.)
- Problems with the engine (The applicable text message is displayed.)

NOTICE: Do not continue operating the machine with manual ATS cleaning stopped. If you continue operating the machine, it can damage the ATS system. Resume manual ATS cleaning as soon as possible.

Manual ATS cleaning becomes disabled in the following situations.

- A message that requests manual ATS cleaning "PUSH ATS CLEANING SWITCH TO ACTIVATE" was displayed but cleaning did not start within 10 h.
- Manual ATS cleaning was not completed within 40 min after it started.

When the ATS cleaning icon changes from orange to red, an alarm sounds for about 2 s and the red text message "SERVICE ATS" is displayed.

This indicates that an abnormality has occurred that requires a repair. Contact your CASE CONSTRUCTION dealer immediately.

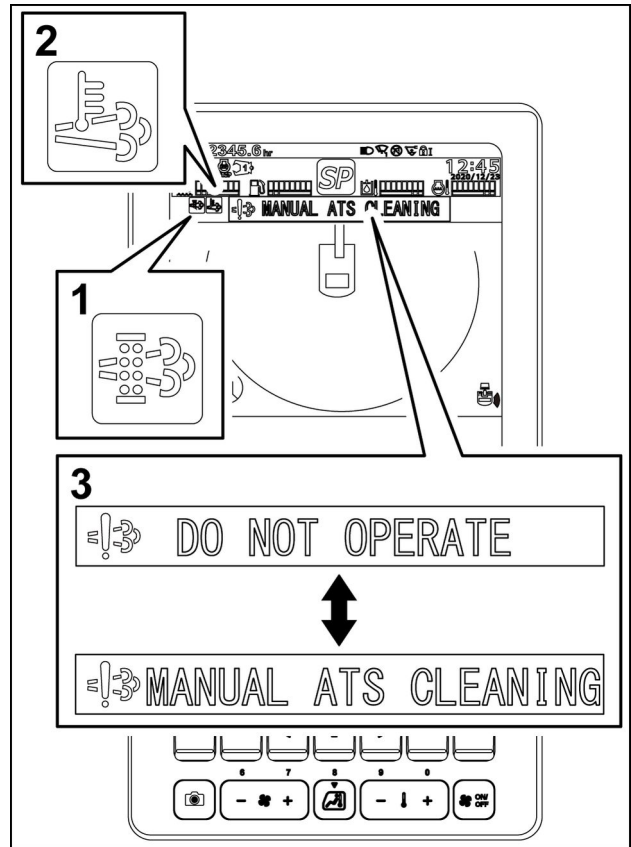

SMIL21CEX4348BA 13

Hydrocarbon (HC) Accumulation

Running the engine at low idle continuously causes hydrocarbons to accumulate. To burn the hydrocarbons, the engine speed needs to be increased. The system detects the amount of hydrocarbon accumulation and increases the low idle speed to burn the hydrocarbons.

While the system is starting up, the low idle speed increase icon (1) stays lit in green. If hydrocarbons accumulate while the engine is running at low idle and the gate lock lever is in the center position (with safety bar in the non-operation position), the green low idle speed increase icon (1) and orange hydrocarbon accumulation icon (2) light up and the low idle speed is automatically increased.

Once the excavator is operated and the engine speed increases, the low idle speed increase icon (1) goes out.

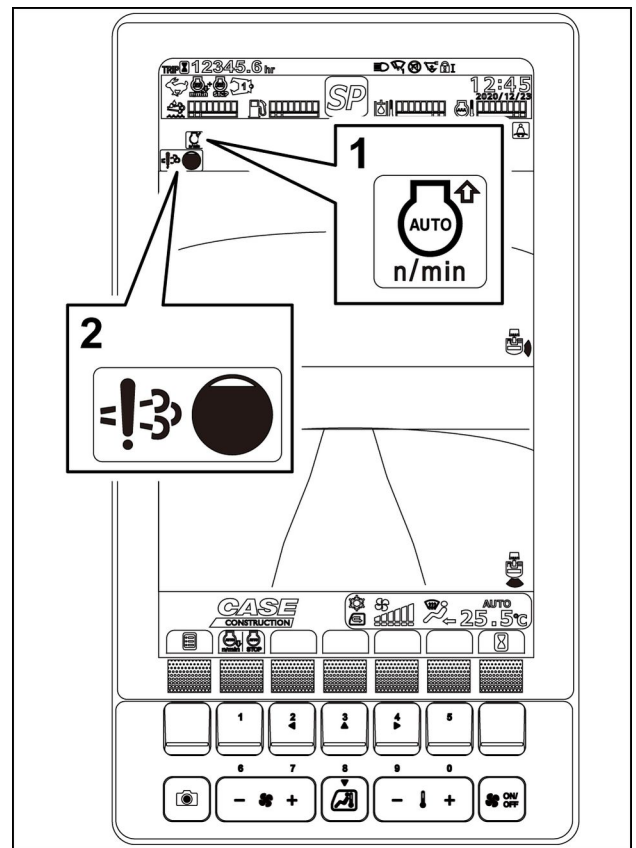

SMIL21CEX4349BA 14

If hydrocarbons accumulate when the gate lock lever is in the normal operating position (with the safety bar raised), the low idle speed increase icon (1) and hydrocarbon accumulation icon (2) light up in orange and the text message (3) "INCREASE ENGINE SPEED" is displayed.

When this happens, move the gate lock lever to the center position (with safety bar in the non-operation position). The text message (3) disappears (the hydrocarbon accumulation icon (2) remains the same) and the low idle speed increase icon (1) lights up in green and the low idle speed is automatically increased.

If hydrocarbons accumulate even more, the hydrocarbon accumulation icon (2) and text message (3) change from orange to red. When this happens, increase the engine speed immediately. Keep the engine speed high until the hydrocarbon accumulation icon (2) goes out.

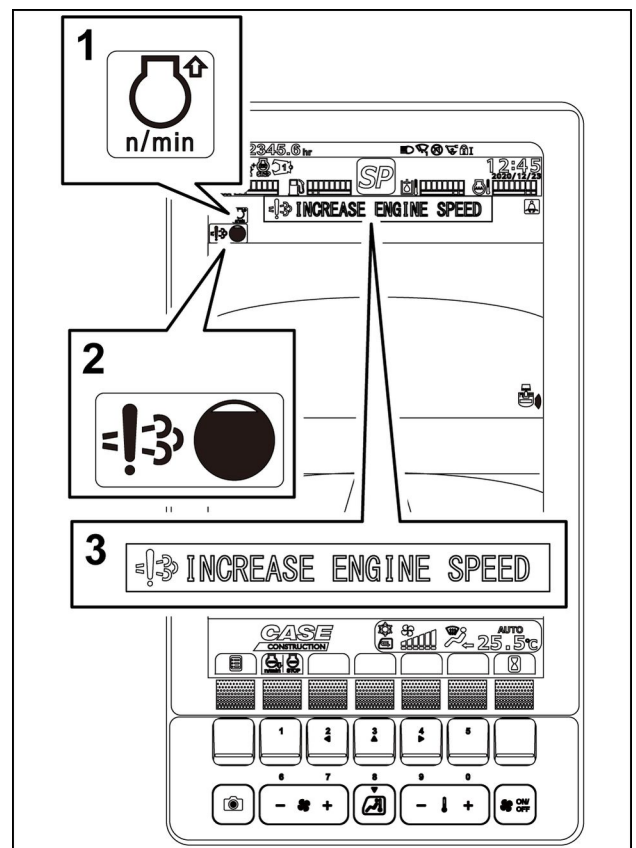

SMIL21CEX4350BA 15

