

**HYDRAULIC ROCK BREAKER  
CB230**

CX210, CX220, CX235

**CASE**

CONSTRUCTION



**BREAKTHROUGH ANY  
OBSTACLE WITH ROCK  
BREAKER ATTACHMENT**

CaseCE.com  
**EXPERTS FOR THE REAL WORLD  
SINCE 1842**

Attachments.  
BUSINESS SOLUTIONS

**CASE**  
CONSTRUCTION

# ROCK BREAKER CB230

## INTRODUCTION

**CASE Genuine Parts product range offers strong, reliable & productive hydraulic Rock Breaker for Loader Backhoes with a complete range of hammer tools for all the applications.**

**This offers customers the freedom to choose the best tool combination, according to machine requirement, which ensures maximum productivity.**



**To meet our mission of extending full product/parts support to our dealers and customers with a comprehensive solution for their requirements, CASE has launched its Rock Breaker. CASE Rock Breaker mounting accessories, brackets and hose kits are CASE engineered and designed, for maximum efficiency in all its applications. This also includes pin and bushing kits, hose kits and mounting brackets for all CASE machines.**

**CASE Rock Breaker are supported throughout India with spare parts, manuals and technical support at all times to minimize downtime and maintain application demand. CASE Rock Breaker installations are taken care by CASE After-Sales Support Team throughout India, and integrates the dealer and customer with its Attachment Product Training to sync into the CASE system.**



## FEATURES

- **Technology gives consistent performance on every blow**
- **Easy service and maintenance**
- **Low fatigue on base machines**
- **High Returns on Investments**
- **Low running cost**
- **Ensured reliability**
- **Quality verified & approved by CASE engineering team**
- **CASE Rock Breaker with across the nation warranty**
- **High impact energy & Impact rate**

## TYPE

- **CASE Rock Breaker provide optimized rotation angles & allow a wide range of work positions.**
- **Fully enclosed power cell for maximum component protection from work materials**
- **Sound absorbing elements inside housing, lower noise output for sound sensitive applications**

# ROCK BREAKER CB230

## TECHNICAL SPECIFICATIONS

<b>Operating weight*</b>	1,873 kg
<b>Breaker bracket weight</b>	236 kg
<b>Operating pressure</b>	160~190 kg/cm <sup>2</sup>
<b>Port relief setting pressure**</b>	210 kg/cm <sup>2</sup>
<b>Oil flow</b>	119~161 lpm
<b>Blow rate Power mode</b>	340~450 bpm
<b>Blow rate Speed mode</b>	420~550 bpm
<b>Tool diameter</b>	135 mm
<b>Suitable carrier</b>	20~26 ton
<b>Allowable back pressure</b>	22 bar

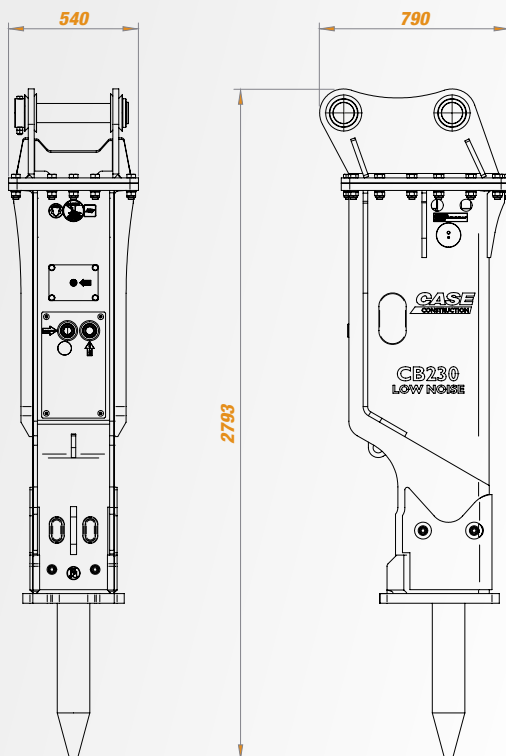

Conventional tool	Application type				
	Primary breaking	Secondary breaking	Hard rock removal	Soft material & rock removal	Demolition
Moil	●		●	●	●
Chisel	○		○	●	●
Blunt		●			○

Special tool	Application type		
	Asphalt removal	Compacting	Post driving
Spade	●		
Compacting		●	
Elephant foot			●

**Note:**

\* Operating weight includes breaker bracket with 2 pins, one work tool and two hydraulic hoses. Operating weight is only indicative one for the purpose of sharing with Buyer and subject to change.

\*\* Guide for carrier port relief valve pressure setting.

**SMART DESIGN**

**HOUSING & POWER CELL**

- Power cell floating system
- No metal to metal contact, bolt free
- Fully enclosed power cell

**NOISE PROTECTOR**

- Less noise (silenced type)

**INTERNAL VALVE SYSTEM**

- Energy efficient internal control valve system

**RETURN LINE BACK PRESSURE**

- Allowable up to 44 bar (highest in the industry)

**LARGE CAPACITY ACCUMULATOR & DIAPHRAGM**

- Protect carrier hydraulic components from peak pressure
- Accelerate striking speed
- Prevent cavitation and increase seal life time
- Extended diaphragm service life

**BOTTOM PLATE (HARDOX/AR400)**

- Protect housing structure
- Increase housing service life

**TOOL**

- Heat treated tool
- Longer wear life

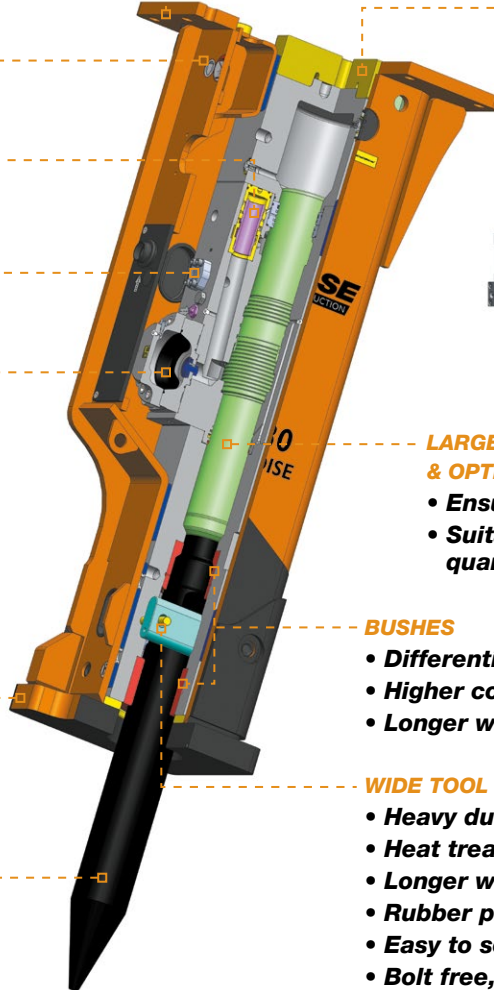

**CUSHION DAMPER**

- Absorb repercussion from hammering and increases carrier endurance

**AUTO LUBRICATION SYSTEM**

- Increase tool, tool pins, bush life time
- Vibrating type

**LARGER GAS CHAMBER & OPTIMUM PISTON SIZE**

- Ensure higher impact power and speed
- Suitable for secondary rock breaking quarry application

**BUSHES**

- Differentiated heat treatment
- Higher core hardness
- Longer wear life

**WIDE TOOL PIN**

- Heavy duty oval shape dual pins
- Heat treated pins
- Longer wear life
- Rubber plugged on all mounting holes
- Easy to service
- Bolt free, low maintenance cost

Corporate Identity Number: U29240MH1998PTC117183  
**CASE NEW HOLLAND CONSTRUCTION EQUIPMENT (INDIA) PRIVATE LIMITED**  
 B1-207, 2nd Floor, Boomerang, Chandivali Farm Road  
 Near Chandivali Studio, Andheri (East)  
 Mumbai - 400072, Maharashtra, India  
 Email: caseindia@cnhind.com

**NOTE:** CASE provides specific outfits for various countries and many optional fittings (OPT). The illustrations on this or other leaflets may relate to standard or optional fittings. Please consult your CASE dealer for any information in this regard and any possible updating on components. CNH Industrial reserves the right to modify machine specifications without incurring any obligation relating to such changes.

Follow us on @caseceindia

**CASE** Customer Assistance  
**1800 4199 770**