



AUSTOFT® 4000 SERIES

SUGARCANE HARVESTERS



A smiling man with short dark hair, wearing a dark blue t-shirt, stands in a field of tall green grass. The background is a dense field of grass, and the man is positioned on the right side of the frame. A red banner is at the bottom left.

**WHERE THERE IS
ADVANCED AGRICULTURE,
THERE IS CASE IH.**



Case IH is a global leader in the state-of-the-art technology, performance and productivity in agricultural mechanization. Its product line is present in more than 160 markets on the five continents, offering advanced solutions from planting to harvesting.

The high performance provided by Case IH sugarcane harvesters results from 75 years of knowledge and experience in the sector, making it the leader in production and sales of equipment for mechanized sugarcane harvesting.





INNOVATION WITHOUT LIMITS.

A registered trademark of Case IH.

Case IH. Committed to the evolution of the global sugar and ethanol sector.

This time Case IH launches a new and improved sugarcane harvester: the new Case IH Austoft 4000 is here.

It is a compact harvester designed especially to make it possible to streamline the harvesting process in sugarcane fields that use reduced row spacings from 1.1 and 1.2 meters.

BETTER CUTTING QUALITY AND LONGER STOOL LIFE IN THE SUGARCANE FIELD.

The Austoft 4000 sugarcane harvester represents once again the pioneering spirit of Case IH. Working in row spacings from 1.1 and 1.2 meters this harvester is narrow enough to harvest one row without compacting the root zone of the adjacent cane row. It is compact, light, has excellent maneuverability and an excellent base cut resulting in reduced cane loss and increased productivity in subsequent ratoon crops. The Austoft 4000 is designed to harvest crops up to 85 tons per hectare.

MORE VERSATILITY WITH THE AUSTOFT 4000 SUGARCANE HARVESTER.

Designed for maximum performance, the Austoft 4000 demonstrates its versatility by harvesting both in sugarcane fields with reduced spacings of 1.1 and 1.2 meters as well as in sugarcane fields with wider row spacings up to 1.5 meters. By harvesting in all of these row spacings, the Austoft 4000 becomes a superb option for those cane growers who need or wish to start harvesting mechanically, or for big plantation areas where the Austoft 4000 can harvest short rows and or low productivity soils, freeing the bigger volume harvesters like the Austoft 8010 series, in order to harvest to their full daily harvest capacity. This represents a significant gain in machine productivity

FIND OUT MORE ABOUT THE AUSTOFT 4000

FEEDING SYSTEM:

- 2 Crop Dividers:** lifts and separates the row of sugarcane that is being harvested from the adjacent rows.
- 3 Knockdown roller:** guides and inclines the bundle of sugarcane to be cut, facilitating the base cutting operation and feeding the machine
- 4 Feedroller (finned):** helps feed the bundle of sugarcane for base cut.
- 5 Basecutter:** cuts the sugarcane at ground level and carries the bundle of sugarcane to the buttlifter roller.
- 6 Buttlifter roller:** lifts the bundle of sugarcane cut by the basecutter and guides it into the machine to the feed rollers.

TOPPING SYSTEM:

- 1 Topper:** cuts off the sugarcane's tops and leaf and spreads them out on the field in a uniform fashion.

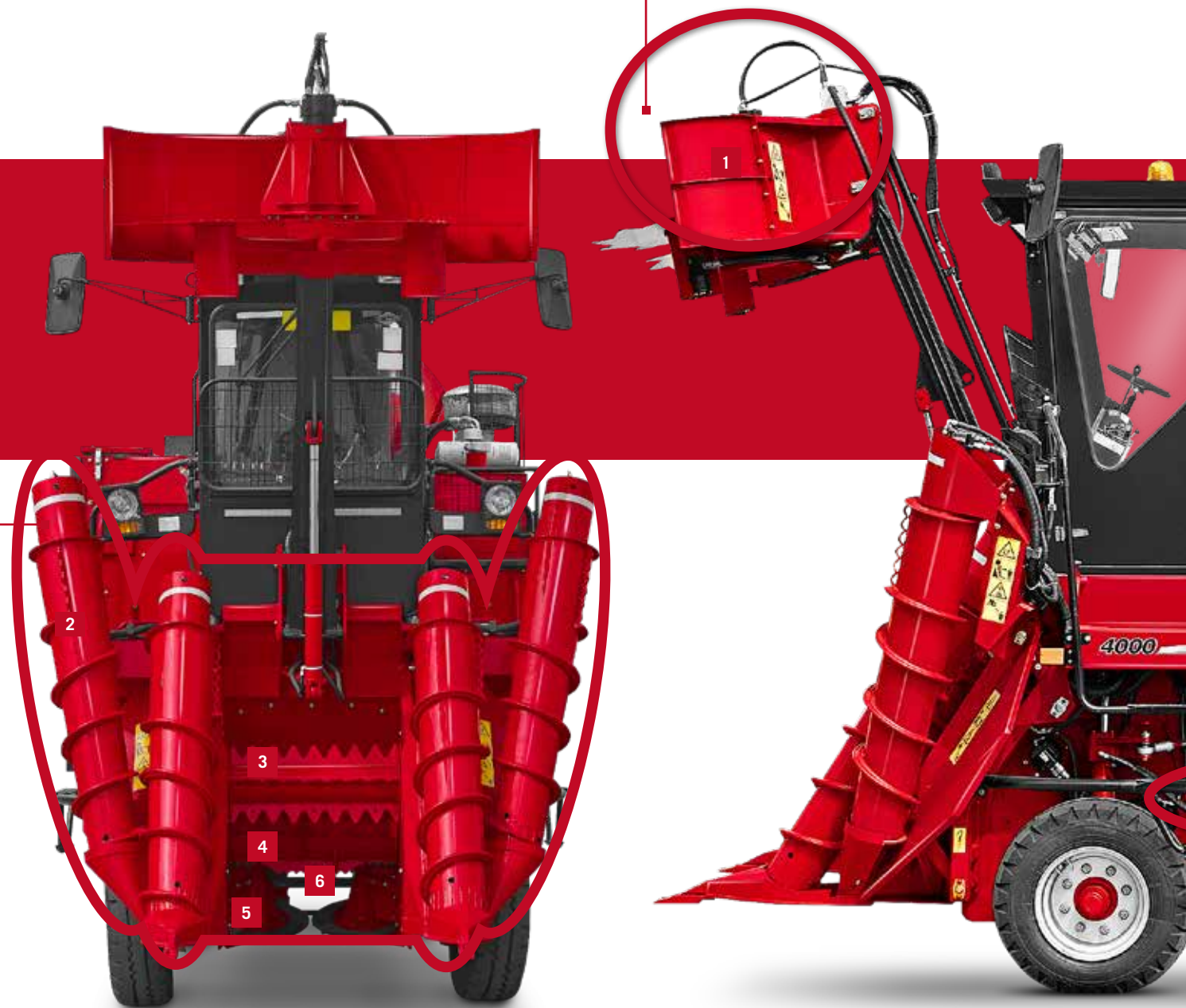

FEEDING SYSTEM:

7 Feed Rollers: transports and horizontally feeds the cane stalks to the chopper drums.

ANTIVORTEX CLEANING SYSTEM:

9 Extractor: cleans the billets, removes the trash and other impurities

CHOPPING SYSTEM:

8 Chopper Drums: cuts the sugarcane and sends the billets to the extractor chamber.

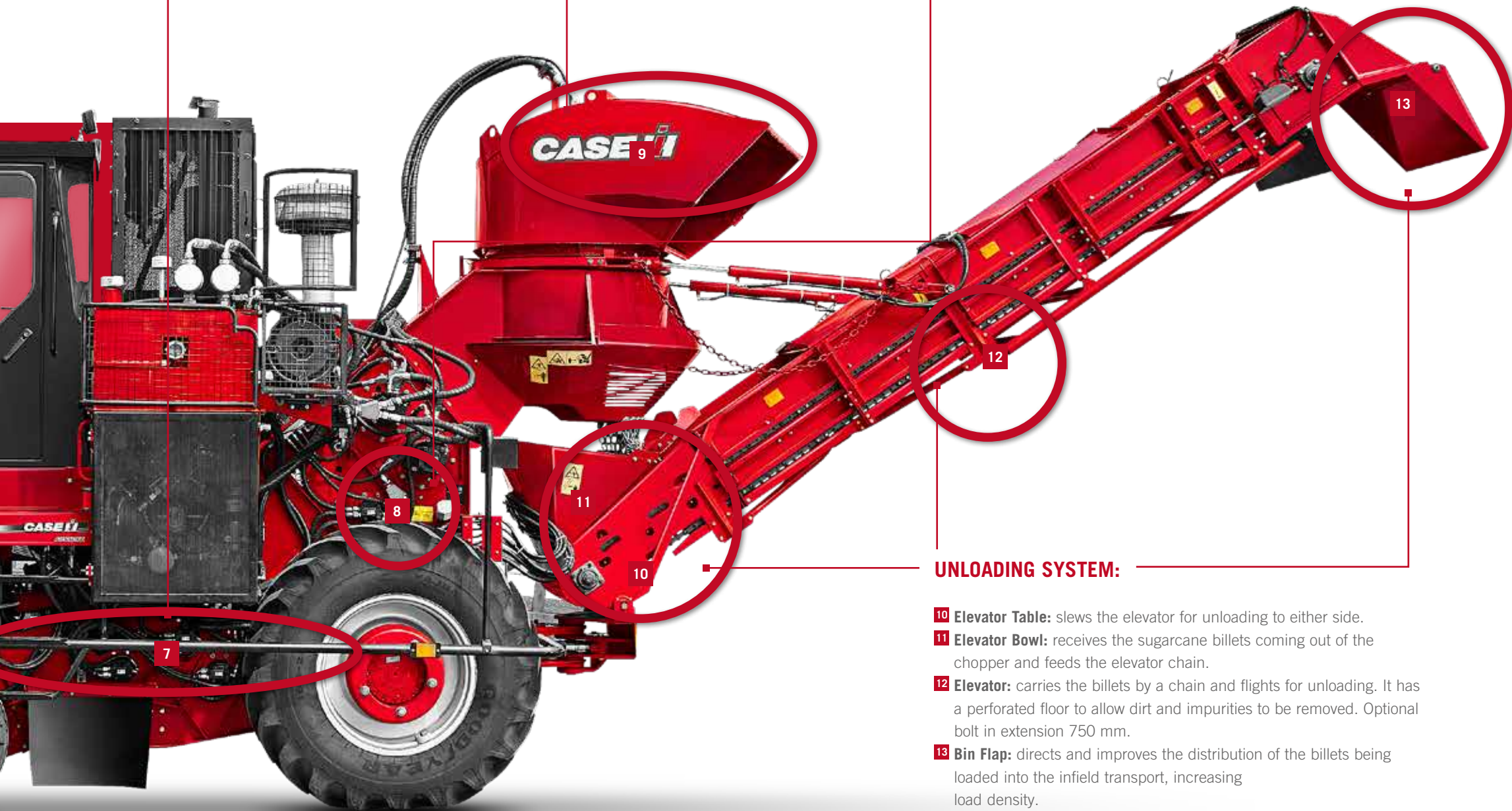

UNLOADING SYSTEM:

- 10 Elevator Table:** slews the elevator for unloading to either side.
- 11 Elevator Bowl:** receives the sugarcane billets coming out of the chopper and feeds the elevator chain.
- 12 Elevator:** carries the billets by a chain and flights for unloading. It has a perforated floor to allow dirt and impurities to be removed. Optional bolt in extension 750 mm.
- 13 Bin Flap:** directs and improves the distribution of the billets being loaded into the infield transport, increasing load density.



FLEXIBILITY, RELIABILITY AND COMFORT.

EXCELLENT COST-BENEFIT

The Austoft 4000 is smaller in size compared to the conventional models, and is easy to move between cane fields. The Austoft 4000 was designed with the same functional concept as the A7000 Series harvesters. Because of this, many of its parts are interchangeable with other models of Case IH sugarcane harvesters. This characteristic significantly increases the machine's cost-benefit.

EASY & FAST TO SERVICE

The Austoft 4000 was designed to make maintenance simple. The engine, hydraulic system, and industrial components are easily accessible, streamlining the machine preventive maintenance, increasing the machine's availability.

COMFORT FOR THE OPERATOR

For greater productivity, the Austoft 4000 has operator comfort, good visibility, and operational ease for the operator. The controls are ergonomically positioned to ensure convenience and functionality for the operator during the long working hours.





WORLDWIDE, AN ADVANCED SYSTEM FOR ENSURING HIGH PERFORMANCE OF THE AGRIBUSINESS.

All over the world, agribusiness professionals can count on Case IH for technological innovations, advanced solutions and professional technical support.

Whether your core business is the sugar or the alcohol production, Case IH is always ready to provide you not only with the best cane harvesting technology and dependability, but also with a worldwide network of dealers, parts depots and service workshops, all working together to increase your profitability and assure your peace of mind.

CASE IH ADVANCED SUPPORT

Case IH has an after-sales superstructure with specialized technical assistance and logistics centers for giving support to the client. For a fast and precise customer service experience, dealers and factories exchange technical experiences through Asist, an exclusive program via Internet.

MAINTAIN THE PRODUCTIVITY OF YOUR INVESTMENT

Case IH and its dedicated dealer network provide excellent support when you take delivery of your new machine and whilst it remains in your ownership. On the farm, you can rely on trained service professionals to maintain the productivity of your investment.

DEFEND YOUR WORK, INVESTMENT AND EQUIPMENT. ALWAYS CHOOSE CNH INDUSTRIAL GENUINE PARTS.

Protect the value of your investment. Behind every Case IH product stands an extensive parts logistics organisation, stocking parts for products both old and new. Choosing to fit genuine Case IH parts will maintain the safety, value and performance of your original investment.



NEW FEATURES

Find out more about the Austoft 4000

- 1 Larger radiator, higher cooling capacity, longer lifespan
- 2 Added USB charging port for operator convenience and improved communication
- 3 Windscreen protector preventing damage from the cane
- 4 Elevator cane flap to reduce spillage
- 5 Larger rear wheels, improved stability, reduced compaction
- 6 eView™ operating rear cameras. Located on the sides of the cab roof for monitoring the elevator and can be easily monitored from a screen in the cab



2 speeds engine cooling fan

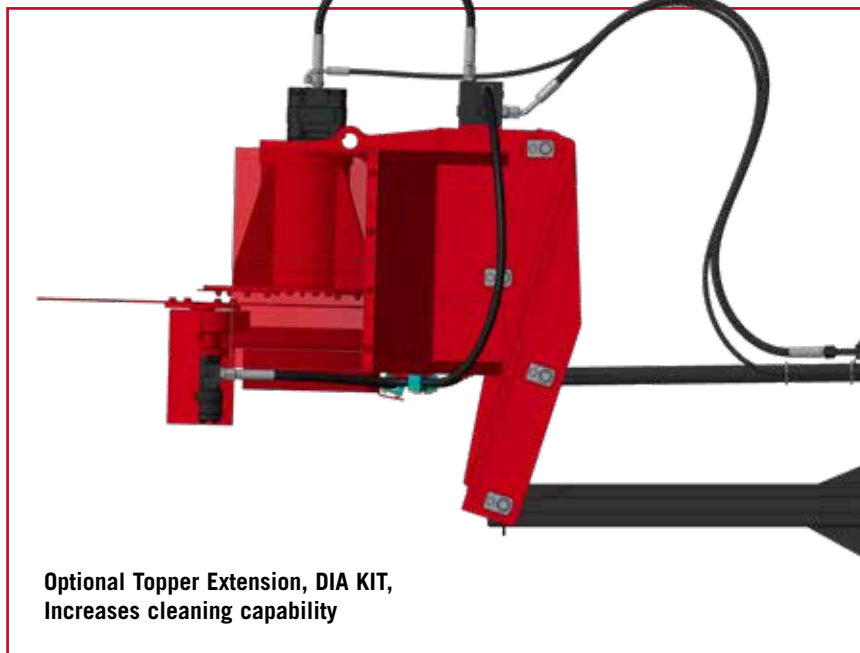

Optional Topper Extension, DIA KIT, Increases cleaning capability

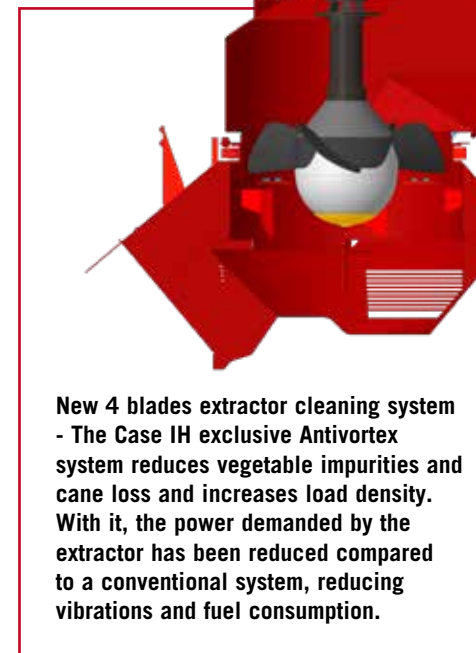

New 4 blades extractor cleaning system - The Case IH exclusive Antivortex system reduces vegetable impurities and cane loss and increases load density. With it, the power demanded by the extractor has been reduced compared to a conventional system, reducing vibrations and fuel consumption.

MODEL	AUSTOFT 4000
ENGINE	
Make	FPT
Series	NEF
Power (hp/kw)	168 / 125
Cylinder volume (l)	6,7
Aspiration	Turbo / Aftercooler
TRANSMISSION	
Type	Hydrostatic
Travel speed (Km/h)	16
CAPACITY	
Fuel tank (l)	210
Hydraulic oil tank (l)	130
TYRES	
Front	10.5 x 16 10-ply
Rear	16.9 x 28 R-1 10-ply
TOPPER	
Height variation (mm)	1,050 to 3,000
optional extension(mm)	500
Height adjustment	Hydraulic
CROP DIVIDERS	
Distance between the points (mm)	1,100
Spiral angle (°)	30
Height adjustment	Hydraulic
Lower section	Hardened
BASECUTTER	
Drive	Hydraulic and reversible
Number of discs	2, identical and reversible
Number of blades	8, removable
Distance between center of discs (mm)	495
FEED ROLLERS	
Number of rollers	11
Number of rollers on the roller train	8
Drive	Hydraulic and reversible
Upper rollers	Floating
CHOPPER	
Number of blades per drum	3
Deflector plate	Adjustable
KNOCKDOWN ROLLER	
Height	Adjustable
Angle (°)	51
EXTRACTOR	
Number of blades	4
Maximum speed	1,500 (+/- 100) rpm
Hood	Directional
ELEVATOR	
Drive	Hydraulic and reversible
Slewing angle (°)	170
Optional extension (mm)	750 mm
Weight (kg)	8,000 kg

AUSTOFT 4000 – FACTORY-FITTED ITEMS

Air-conditioned cab with 2 doors
Windshield wipers
2 Rear view mirrors
Dash board lighting
Tachometer and hour meter of the engine
Fuel level gauge
Engine oil pressure indicator
Temperature indicators of the hydraulic oil and engine coolant
Battery voltage indicator
Indicator of hydraulic pressure at base cutter and chopper
Safety relays
Safety brake
Gyroflex
Quartz halogen headlights mounted on the cab
USB charging port
Low engine fuel level warning
Traffic lighting
Wind Screen protector
Elevator cane flap

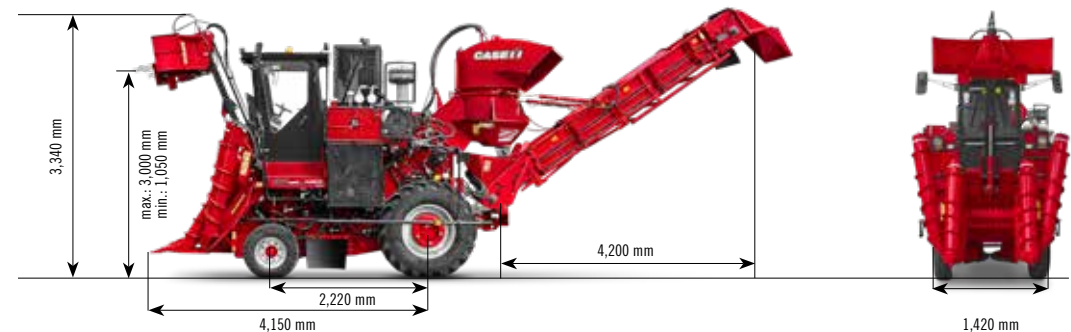

CNH Industrial Asia Pacific
Riva Paradiso, 14 - 6902 Paradiso-Lugano Switzerland

! Safety never hurts! Always read the Operator's Manual before working with any equipment. Inspect equipment before using it, and be sure it is operating properly. Follow the product safety signs, and use any safety features provided. This literature has been published for worldwide circulation. The standard and optional equipment and the availability of individual models may vary from one country to the next. Case IH reserves the right to undertake modifications without prior notice to the design and technical equipment at all times without this resulting in any obligation whatsoever to make such modifications to units already sold. Whilst every effort is made to ensure that the specifications, descriptions and illustrations in this brochure are correct at the time of going to press, these are also subject to change without prior notice. Illustrations may show optional equipment or may not show all standard equipment. Case IH recommends **AKCELA** lubricants.

Case IH Austoft 4000 Series – 06/2019 –
Code 19AMEACOMAU003

WWW.CASEIH.COM

CASE IH
AGRICULTURE