

ML35 T

TELESCOPIC REACH SMALL ARTICULATED LOADER



OPERATING WEIGHT	
Open cab	8,818 lb. (4000 kg)

OVERALL DIMENSIONS	
Overall height	89.6 in. (2275 mm)
Overall length:	
Without bucket	160.1 in. (4067 mm)
Machine width	52.8 in. (1340 mm)

LOADER PERFORMANCE SPECS	
Lifting height	169.8 in. (4312 mm)
Tipping load (ISO) – Straight	See graph page 2
Lifting capacity	See graph page 2

ELECTRICAL	
System voltage	12 volts
Alternator	60 amp
Battery	77 AHR 520 cold-cranking amps

ENGINE	
Model	Kubota V2403 CR
Emissions certification	Tier 4 Final Certified
Cylinders	4
Displacement	148.5 in. ³ (2.434 L)
Fuel	Diesel
Exhaust aftertreatment	DOC + DPF
Engine speeds	RPM
Rated – full load	2,700
Horsepower @ 2,700 RPM – SAE J1349:	
Gross	65 hp (48.6 kW)
Peak torque @ 1.600 RPM	146.4 lb-ft (198.5 N-m)

DRIVETRAIN	
Transmission type	Hydrostatic, 2 speed
Differential type	Open Center w/ Differential Lock
Parking brake:	
Type	Drum
Max. travel speed	
Turtle	6.2 mph (9.9 kph)
Rabbit	18.6 mph (30 kph)

HYDRAULICS	
Control valve type	Open center
Pump type	Fixed gear
Driving hydraulics:	
Flow rate	29.6 gpm (112 L/min)
Operating pressure	6,500 psi (450 bar)
Working Hydraulics:	
Total flow rate	18.5 gpm (70 L/min)
Operating pressure	3,200 psi (220 bar)
Auxiliary 1:	
Max. flow rate	18.5 gpm (70 L/min)
Pressure	3,200 psi (220 bar)
Auxiliary 2 — optional:	
Max. flow rate	18.5 gpm (70 L/min)
Pressure	3,200 psi (220 bar)
Continuous flow — optional:	
Max. flow rate	13.2 gpm (50 L/min)
Pressure	3,200 psi (220 bar)

SERVICE CAPACITIES	
Fuel tank	18 gal. (68 L)
Engine oil w/ filter	10 qt. (9.5 L)
Hydraulic system	15.9 gal. (60 L)
Engine coolant	3 gal. (11.4 L)

Standard Equipment

Operator Environment

- ROPS/FOPS safety roof
- Safety entry bar
- Key start
- Air suspension vinyl seat
- Armrests
- Retractable seat belt
- Exterior mirrors

Engine

- Diesel oxygen catalyst
- Diesel particulate filter
- Glow plug starting aid
- Engine block heater
- Locking fuel cap
- Cyclone air filter

Drivetrain

- Hydrostatic 4-wheel drive
- FNR control on joystick
- Electrical differential lock axles
- Drum brakes

Hydraulics

- 3-spool main control valve
- 1x dual acting auxiliary hydraulics
- Attachment case drain return
- Hydraulic self-level function
- Hose rupture protection on lift cylinder
- Oil cooler

Loader

- Telescopic reach loader arm
- Loader lift arm support strut
- SSL compatible attachment coupler, hydraulic powered
- Additional counterweights

Electrical

- 12 volt system
- 77 AHR, 780 CCA battery
- 60 A alternator
- 1 boom worklight
- 2 front cab work lights
- Anti-theft protection with access code
- Battery disconnect switch

Other Standard Features

- Tow coupling
- Backup alarm
- Horn

Warranty

- Base warranty coverage: 2-Year/1,000-Hour Full Machine Limited Warranty

Optional Equipment

Operator Environment

- Enclosed cab with HVAC

Engine

- Hand throttle

Drivetrain

- Pro inching creep control

Hydraulics

- 2x dual acting auxiliary hydraulics
- Auxiliary hydraulic hold function
- Continuous flow auxiliary hydraulics
- Hydraulic boom suspension (ride control)

Electrical

- 2 cab rear work lights
- 14-pin electrical auxiliary connection
- Rotating beacon light
- Strobe light

Other

- English, Spanish, or French operator manual

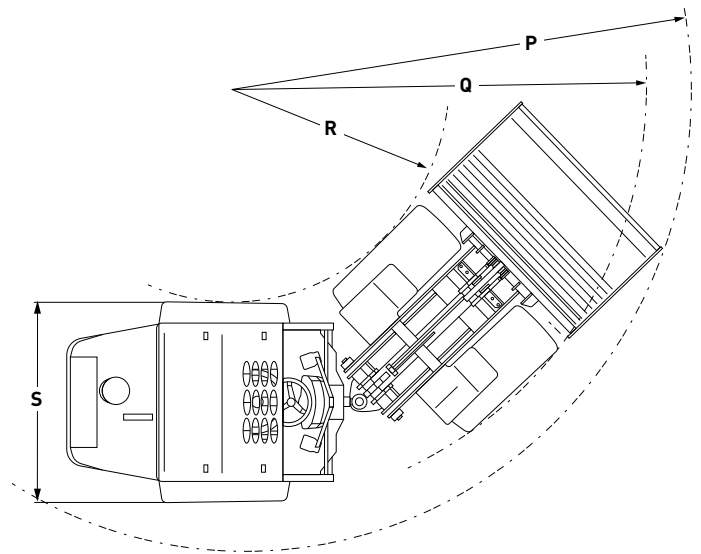
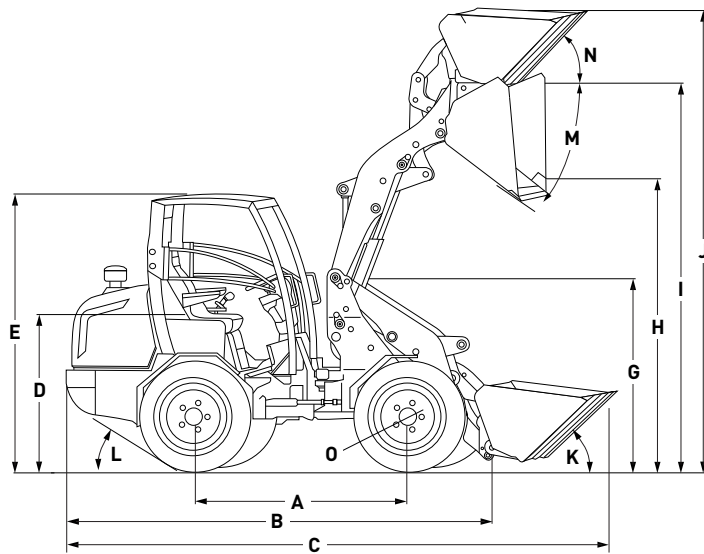

DIMENSIONS

A	Wheelbase	77.6 in. (1972 mm)
B	Total length	160.1 in. (4067 mm)
C	Length with bucket	195.4 in. (4965 mm)
D	Seat height	50.0 in. (1270 mm)
E	Max. height with safety roof	89.6 in. (2275 mm)
F	Max. height with cabin	89.6 in. (2275 mm)
G	Height front frame	69.9 in. (1775 mm)
H	Max. dumping height	134.3 in. (3410 mm)
I	Lifting height	169.8 in. (4312 mm)
J	Height with bucket	77.0 in. (1955 mm)
K	Rollback angle on the ground	42°
L	Rollback angle at max. lift height	55°
M	Max. dumping angle	37°
N	Max. loading angle	22°
O	Outer size of tires	37.0 in. (940 mm)
P	Maximum radius external	142.3 in. (3615 mm)
Q	Turning radius on outer edge	124.0 in. (3150 mm)
R	Inner turning radius	65.9 in. (1675 mm)
S	Width on standard tires	52.8 in. (1340 mm)

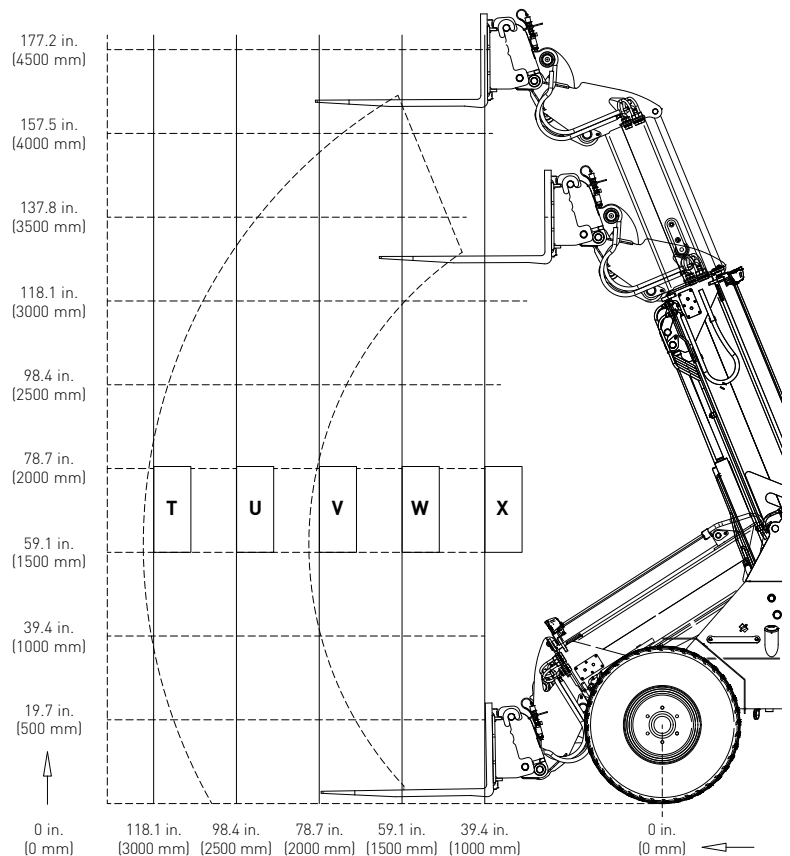

Line drawings are for illustrative purpose only and may not be exact representation of unit.

TIPPING LOAD PATHS

T	1,630 lb. (740 kg)
U	1,770 lb. (805 kg)
V	2,810 lb. (1275 kg)
W	3,750 lb. (1700 kg)
X	5,510 lb. (2500 kg)



New Holland Construction
500 Diller Ave.
New Holland, PA 17557

Learn more at www.newholland.com



Design, materials and/or specifications are subject to change without notice and without liability therefor. Specifications are applicable to units sold in Canada, the United States, its territories and possessions, and may vary outside these areas.

© 2023 CNH Industrial America LLC. All rights reserved. New Holland is a trademark registered in the United States and many other countries, owned by or licensed to CNH Industrial N.V., its subsidiaries or affiliates. Any trademarks referred to herein, in association with goods and/or services of companies, other than owned by or licensed to CNH Industrial N.V., its subsidiaries or affiliates, are the property of those respective companies.



Safety begins with a thorough understanding of the equipment. Always make sure you and your operators read the Operator's Manual before using the equipment. Pay close attention to all safety and operating decals and never operate machinery without all shields, protective devices and structures in place.