

E30C

COMPACT EXCAVATOR

TIER 4 FINAL



Engine

Model	Kubota D1305
Emission certification	Tier 4 Final
Fuel	Diesel
Cylinders	3
Displacement	77.0 in. ³ (1261 cc)
Fuel Injection	Mechanical
Gross horsepower	SAE J1995 @ 2300 RPM: 24.8 hp (18.5 kW)
Net horsepower	SAE J1349 @ 2300 RPM: 23.2 hp (17.3 kW)
Maximum engine torque @ 1600 RPM	60.00 lb. ft. (81.4 Nm)
Cooling	Water-cooled

Drivetrain

Travel speeds:	
1st	1.5 mph (2.4 kph)
2nd	2.7 mph (4.3 kph)
Maximum traction force	4800 lb. (2177kg)
Gradeability	30° (58%)
Ground pressure:	
Canopy	3.8 psi (0.27 kgf/cm ²)
Cab	4.1 psi (0.29 kgf/cm ²)

Electrical

Voltage	12 Volts
Alternator rating	40 amp
Battery	1 x 12 V x 80 Ah 630 CCA

Operator Weight

Canopy operating weight	6306 lb. (2860 kg)
Cab operating weight	6636 lb. (3010 kg)

NOTE: w/rubber tracks/no quick coupler/bucket/fluids/full of fuel/165 lb. operator.

Operator Environment

ROPS/FOPS four post canopy; ISO 6396:2008 sound pressure level LpA=73.5 dB [A]; Pilot operated hand controls and foot pedals; Adjustable seat w/seat belt; Arm rests; 12V socket.

Display includes:
 Engine oil pressure lamp; Water temperature lamp; Low fuel warning lamp; Battery charge lamp; Engine preheat lamp; Travel speed lamp; Air cleaner warning lamp; Hyd. quick coupler lock lamp; High travel speed lamp; Water temperature gauge; Fuel gauge; and Hour meter.

Service Capacities

Fuel tank	7.9 gal. (30 L)
Hydraulic tank:	
Refill capacity	7.1 gal. (27 L)
Total system	14.5 gal. (55 L)
Engine oil w/filter change	1.6 gal. (5.9 L)
Radiator	1.3 gal. (5 L)

Hydraulics

Main pumps:	
Variable displacement tandem axial piston pump	
Max rated flow x 2	7.3 gpm (27.6 L/min)
Auxiliary flow @ 3132 (216 bar):	
Primary	12.2 gpm (46L/min)
Secondary	12.2 gpm (46L/min)
System relief pressure:	
Standard	3130 psi (220 bar)
Overload relief valve pressure	3430 psi (240 bar)
Pilot control hydraulic system:	
Pump	Gear pump
Maximum capacity	2.7 gpm (10.4 L/min)
Control valves:	
Pilot control for left/right track travel, boom, arm, bucket and swing	
Manual control for breaker and backfill blade	
Swing motor	Fixed displacement orbit axial piston motor
Travel motor:	
Variable displacement axial piston	
2-stage planetary	
Automatic spring applied hydraulic released brake	

Other Specifications

Swing speed	0 – 9.1 RPM
Undercarriage:	
Track rollers	1 upper / 4 lower each
Boom:	
Swing	75° left/50° right
Length	6 ft. 8 in. (2.03 m)
Arm:	
Standard length	3 ft. 8 in. (1.12 m)

E30C SPECIFICATIONS

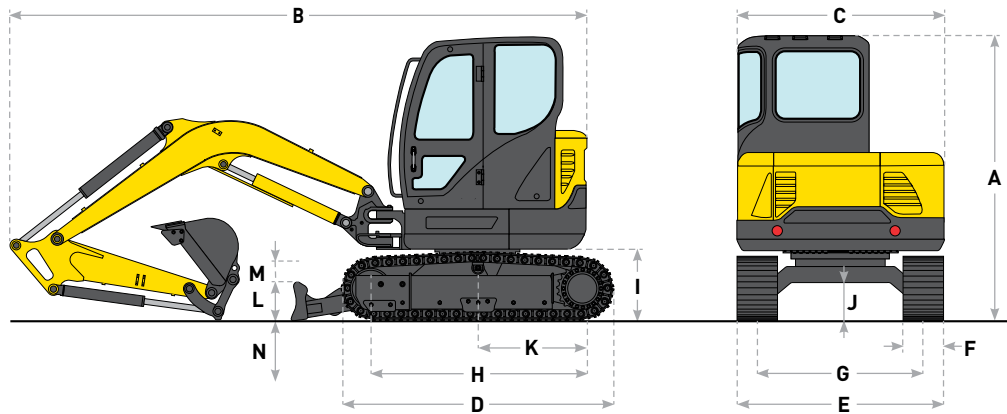

Dimensions			
3 ft. 8 in. (1.12 m) Arm			
A	Overall height	ft. in. (mm)	8' 2" (2500)
B	Overall transport length	ft. in. (mm)	13' 9" (4180)
C	Width of upper structure	ft. in. (mm)	4' 10" (1485)
D	Track overall length	ft. in. (mm)	6' 6" (1970)
E	Track overall width	ft. in. (mm)	5' 1" (1550)
F	Track shoe width	in. (mm)	11.8 (300)
G	Track gauge	ft. in. (mm)	4' 1" (1250)
H	Center to center – idler to sprocket	ft. in. (mm)	4' 11" (1490)
I	Upper structure ground clearance	ft. in. (mm)	1' 8" (510)
J	Minimum ground clearance	in. (mm)	11 (290)
K	Tail swing radius:		
	Standard counterweight	ft. in. (mm)	2' 6" (750)
	Additional counterweight	ft. in. (mm)	2' 10" (875)
	Boom swing	degrees	75 left/50 right
	Tail swing overhang:		
	Standard counterweight	in. (mm)	0 (0)
	Additional counterweight	in. (mm)	5 (125)

Blade Specs			
L	Backfill blade height	ft. in. (mm)	1' 1" (330)
M	Backfill blade rise above ground	ft. in. (mm)	1' 7" (482)
N	Backfill blade dig depth	ft. in. (mm)	1' 6" (450)
	Backfill blade width	ft. in. (mm)	5' 1" (1550)

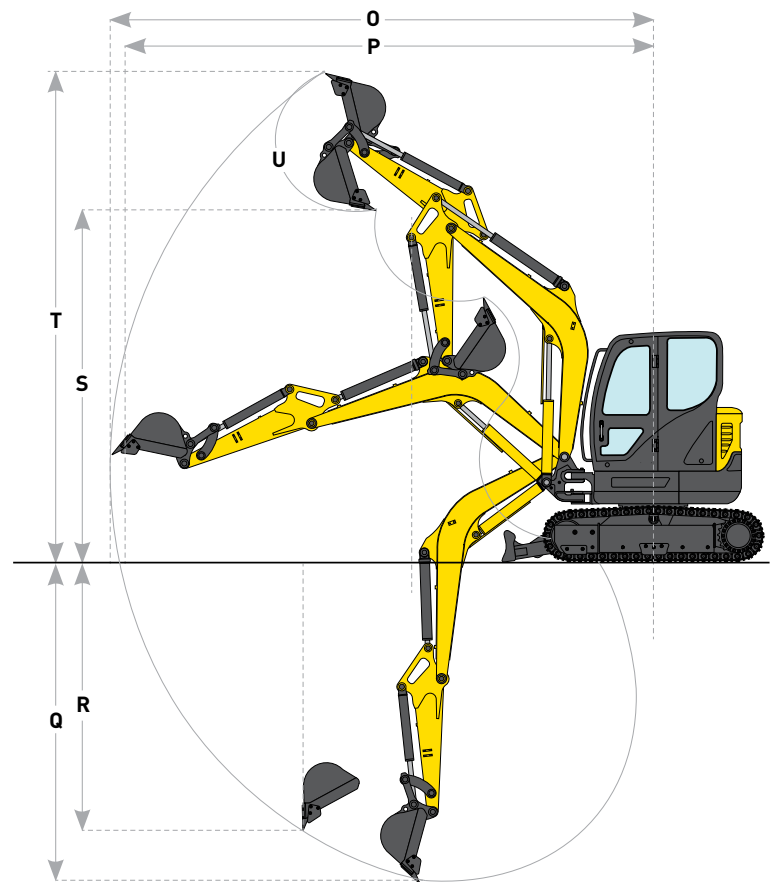

Performance Specs			
3 ft 8 in (1.12 m) Arm			
O	Maximum dig radius	ft. in. (mm)	15' 3" (4650)
P	Dig radius at groundline	ft. in. (mm)	14' 10" (4515)
Q	Maximum dig depth	ft. in. (mm)	8' 2" (2500)
R	Vertical straight wall dig depth	ft. in. (mm)	6' 10" (2085)
S	Dump height	ft. in. (mm)	9' 7" (2930)
T	Overall reach height	ft. in. (mm)	14' 0" (4270)
U	Bucket rotation	degrees	177
	Arm digging force – ISO	lbf (kfg/kN)	3080 (1397/13.7)
	Bucket digging force – ISO	lbf (kfg/kN)	4520 (2050/20.1)

Line drawings are for illustrative purpose only and may not be exact representation of unit

Lift Capacities E30C Standard Arm Lift

6 ft. 8 in. (2.03 m) Boom, 3 ft. 8 in. (1.12 m) Arm, Dozer Blade Down

Canopy unit equipped with 0.08 m³ (SAE heaped) bucket, 10 in. (250 mm) rubber track and 772 lb. (350 kg) counterweight.

Load/Lift point height		Load Radius										At Maximum Reach		
		7 ft. (2.0 m)		8 ft. (2.5 m)		10 ft. (3.0 m)		12 ft. (3.5 m)		13 ft. (4.0 m)		Reach @	Capacity	
		end	side	end	side	end	side	end	side	end	side		end	side
+12 ft. (3.5 m)	lb. (kg)											8 ft. 11 in. (2.73 m)	1200* (550)*	1200* (550)*
+10 ft. (3.0 m)	lb. (kg)					1270* (580)*	1080 (490)					10 ft. 9 in. (3.27 m)	1070* (490)*	920 (420)
+8 ft. (2.5 m)	lb. (kg)					1300* (590)*	1070 (490)	1360* (610)*	810 (370)			11 ft. 11 in. (3.62 m)	1030* (470)*	760 (350)
+7 ft. (2.0 m)	lb. (kg)					1460* (660)*	1050 (480)	1410* (640)*	800 (360)			12 ft. 7 in. (3.84 m)	1030* (470)*	680 (310)
+5 ft. (1.5 m)	lb. (kg)	2840* (1290)*	1970 (890)	2060* (930)*	1370 (620)	1720* (780)*	1010 (460)	1540* (700)*	780 (350)			13 ft. 0 in. (3.96 m)	1060* (480)*	630 (280)
+3 ft. (1.0 m)	lb. (kg)	4070* (1850)*	1830 (830)	2600* (1180)*	1300 (590)	2000* (910)*	970 (440)	1690* (770)*	760 (340)	1170* (530)*	610 (270)	13 ft. 2 in. (4.01 m)	1140* (520)*	600 (270)
+2 ft. (0.5 m)	lb. (kg)	3270* (1480)*	1750 (790)	3000* (1360)*	1240 (560)	2240* (1020)*	940 (430)	1820* (830)*	740 (340)			13 ft. 0 in. (3.97 m)	1260* (570)*	600 (270)
Groundline	lb. (kg)	3820* (1730)*	1730 (780)	3170* (1440)*	1210 (550)	2370* (1070)*	920 (420)	1890* (860)*	730 (330)			12 ft. 7 in. (3.84 m)	1460* (660)*	630 (280)
-2 ft. (-0.5 m)	lb. (kg)	4470* (2030)*	1730 (780)	3130* (1420)*	1200 (550)	2350* (1070)*	910 (410)	1840* (830)*	720 (330)			11 ft. 11 in. (3.62 m)	1720* (780)*	690 (310)
-3 ft. (-1.0 m)	lb. (kg)	4000* (1810)*	1740 (790)	2870* (1300)*	1210 (550)	2150* (980)*	910 (410)					10 ft. 9 in. (3.28 m)	1810* (820)*	800 (360)
-5 ft. (-1.5 m)	lb. (kg)	3160* (1430)*	1780 (810)	2270* (1030)*	1240 (560)							9 ft. 0 in. (2.75 m)	1900* (860)*	1070 (480)

NOTE: Lifting capacity are based on ISO 10567.

Lifting capacity does not exceed 75% of tipping load with the machine on firm, level ground or 87% of full hydraulic capacity.

The lift point is a hook located on the back of the bucket.

*Indicates load limited by hydraulic capacity.

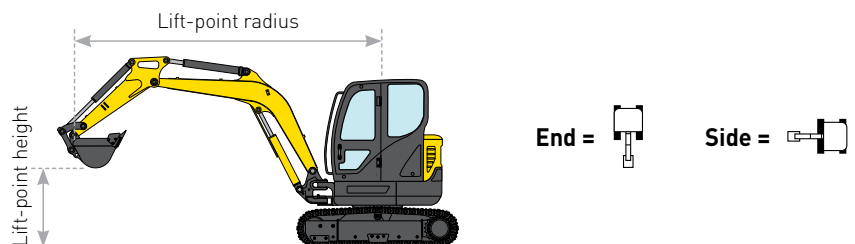

E30C STANDARD EQUIPMENT

Engine
Kubota D1305 diesel
Engine access under rear hood
Glow plug starting aid
Dry type air cleaner with restriction indicator

Electrical
12-volt electrical starting system
Heavy-duty battery
Battery master switch
Key start
Anti-Theft-Engine starting passwords
Front working light
12 V power outlet
Horn
Pre-wired – Telematics ready

Hydraulics
Auxiliary hydraulics – single/bi-directional –and plumbing to arm
Large hydraulic oil cooler
Control pattern selector valve
Cylinder rod protection covers – Dozer, Boom

Track Drive
Rubber belt tracks
Automatic 2-speed travel
Fully hydrostatic drive system
Sealed and lubricated track rollers
Track tension adjustment – grease type

Upper Structure
Zero tail swing
Standard arm: 3 ft. 8 in. (1.12 m)
Bucket linkage with lifting hook

Operator Environment
See page 1

Other
Swing boom – 75° left/50° right
Hydraulic backfill blade
Additional counterweight adds 286 lb. (130 kg)

Warranty
Base warranty coverage: 2-Year/3,000-Hour
Full Machine Limited Warranty

E30C OPTIONAL EQUIPMENT

Operator Environment
Cab with Heat and Radio with USB and 2 speakers
Travel alarm

Other
Thumb bracket
Hydraulic quick coupler provision Hydraulic coupler
Klacc coupler
Mechanical coupler
Hydraulic hammer
Beacon
2nd auxiliary circuit
Hydraulic thumb
Beacon



New Holland Construction Equipment is biodiesel-friendly. NOTE: All engines meet current EPA emissions regulations. All specifications are stated in accordance with SAE Standards or Recommended Practices, where applicable.

Learn more at www.newholland.com

New Holland Construction
500 Diller Ave.
New Holland, PA 17557

www.newholland.com

Design, materials and/or specifications are subject to change without notice and without liability therefor. Specifications are applicable to units sold in Canada, the United States, its territories and possessions, and may vary outside these areas.

© 2021 CNH Industrial America LLC. All rights reserved. New Holland is a trademark in the United States and many other countries, owned by or licensed to CNH Industrial N.V., its subsidiaries or affiliates. Any trademarks referred to herein, in association with goods and/or services of companies other than CNH America LLC, are the property of those respective companies.



Safety begins with a thorough understanding of the equipment. Always make sure you and your operators read the Operator's Manual before using the equipment. Pay close attention to all safety and operating decals and never operate machinery without all shields, protective devices and structures in place. This is a one-person machine. Never allow riders in the cab, outside the machine, or in/on any bucket or attachment.

NHC7130219213 • 0921 • OTP • PRINTED IN U.S.A.