

The new EXPERT series with up to 140 hp

HIGH PERFORMANCE IN A **COMPACT** SHAPE



Your partner to rely on.

STEYR
TRAKTOREN

IT'S THE **TECHNOLOGY** THAT MAKES THE DIFFERENCE

Our team of expert engineers used all their knowledge to design a tractor that brings together maximum control, superior drivability and high performance in a compact package.



The outcome: the EXPERT, the tractor that knows no compromise in terms of comfort, efficiency and quality

Whether on grassland, arable fields, roads or farmyards, the new STEYR EXPERT lives up to its name. The EXPERT is ideal for anyone who needs a compact tractor but does not want to give up on performance and maximum comfort. It features innovations such as the **STEYR S-Control™ CVT** transmission and its S-Tronic control technology and the **STEYR S-Control™ 8** dual clutch technology for uninterrupted power and efficiency in every shift. Only the best is good enough for experts.

» The tool for true experts.

04 – 05
Key features

24 – 25
STEYR loaders

06 – 07
EXPERT at a glance

26 – 27
4WD and stability

08 – 09
Packages

28 – 29
STEYR precision farming

10 – 15
Cab

30 – 31
STEYR FieldOps™

16 – 17
Engine

32 – 33
STEYR service

18 – 19
Transmission

34 – 35
Specifications

20 – 23
Front- and rear linkage area

BENEFIT FROM THE FINEST **TECHNOLOGY**



Premium comfort

Available in both standard and panorama roof versions, for a perfect visibility on the front loader, the 4-pillar cab offers the very best in terms of comfort: leather steering wheel, a choice of seats, the armrest that fits your needs and much more.



S-Tronic custom settings for EXPERT

Individually set-up on the new STEYR 700 Plus monitor your S-Control CVT or new S-Control 8 transmissions settings according to your operation.



Upgraded layout

The ultimate range of remote controls – 2 armrests – Multicontroller II (only EXPERT CVT) for “mechanical” or a mix of “mechanical+electrical” rear remotes or the Multicontroller armrest for 3 or 4 electronic rear remotes.



The STEYR loaders

Whether you're working around the farm yard or in the fields, the new STEYR S front loader series is the perfect match to your tractor and the challenges you face in your day-to-day work.

WHAT MAKES AN **EXPERT**



Low noise level of 69 dB(A) to take the stress out of working and when using a mobile phone hands-free mode.



Up to 18 LED-worklights for perfect 360° illumination.



Three rear PTO speeds with Power mode or with the fuel-efficient ECO mode. Optional stationary PTO.



Maximum rear lift capacity of up to 5,600 and 2,300 kg at the front.



Ergonomic operation using the Multicontroller or Multicontroller II (only EXPERT CVT) armrest.



Dual-Motion driver seat, cab suspension and front axle suspension for more comfort.



Perfect loader work set-up with the STEYR S series front loaders.



Electronic Front Hitch control with implement strain relief more safe and more efficient mowing on steep slopes.



Powerful, economical and ecological: the 4-cylinder engines from 110 up to 140 hp fulfill the Stage V emission standard.



S-Tronic has been further advanced and offers customizable control features.



Combinations of tyres and wheels to suit every type of application.



The EXPERT supports ISOBUS Class II & III for advanced implement compatibility.



S-Control CVT for ultimate efficiency or S-Control 8 dual clutch for smooth, high-productivity power delivery in any condition.



40 kph achieved at a fuel-efficient 1,600 rpm.



STEYR Guide Autoguidance ensuring up to 1.5 cm pass-to-pass and year-over-year accuracy with RTK+.



FieldOps lets you remotely monitor and manage your farm, fleet and data.



Active hold control for stopping on a steep slope without a brake.



Headland management Easy-Tronic II for the automation of work operations, dependent on time and distance covered.



S-Stop Brake to Clutch for smooth control of the tractor and Stop & Go functionality.

AVAILABILITY OF ANY FEATURE DEPENDS ON THE PRODUCT CONFIGURATION

EXPERT ALL INCLUSIVE

Well equipped

Your EXPERT **S-Control 8** is available in three equipment configurations for convenience. Element for economical yet functional solutions, Evolution for high performance and reliability, and Orange designed for municipal applications. Your EXPERT **S-Control CVT** is available in the four mentioned packages plus the Excellence configuration that features the best EXPERT options conveniently. You can quickly select the features that matter to you.

The equipment packages can be changed by STEYR without prior notification. Please contact your local dealer for the latest configuration.



Element

The package for versatile use

The **Element** package is typically designed to offer an economical yet functional solution. It targets large farms and livestock operations where the tractor is used frequently but not continuously and precision fieldwork is not required. Ideal for material handling with a front loader and general maintenance tasks, **Element** ensures reliability, simplicity and low operating costs.

»» FACTS

- ▶ Front axle suspension optional
- ▶ Front linkage options
- ▶ Mechanical remotes and 110 l/min hydraulic pump, 3 speed PTO
- ▶ Multicontroller armrest options
- ▶ Low roof with panorama window or high roof with air conditioning, passenger seat
- ▶ Available for EXPERT CVT and EXPERT **S-Control 8**

Evolution

Evolution in comfort and performance for the customers

The **Evolution** package is typically designed to offer high performance and reliability. It targets small farms (several hectares) where the owner uses the tractor intensively and continuously, including for precision field operations. Ideal for light tillage, transportation and seeding, **Evolution** ensures power, versatility, comfort and top-quality results.

»» FACTS

- ▶ Front axle suspension
- ▶ Front linkage with front hitch management options
- ▶ ElectroHydraulic remotes and 110 l/min hydraulic pump, 3 speed PTO
- ▶ Low roof with panorama window or high roof with air conditioning, passenger seat & suspension
- ▶ Multicontroller armrest options, headland management options on the **STEYR 700 Plus monitor**, & autoguidance options
- ▶ ISOBUS class II optional
- ▶ Available for EXPERT CVT and EXPERT **S-Control 8**

Excellence

High-end performance and superior operator comfort features

Everything you ever dreamed on a tractor, ready for you in package dedicated to excellence. Everything becomes easier, quicker and much more comfortable on the field, on the road and in the yard. And productivity grows.

»» FACTS

- ▶ **S-Control CVT** continuously variable transmission with ultimate mechanical efficiency rating
- ▶ Front axle suspension
- ▶ Front linkage with front hitch management options
- ▶ ElectroHydraulic remotes and 110 l/min hydraulic pump, 3 speed PTO
- ▶ Low roof with panorama window or high roof with air conditioning, passenger seat & suspension
- ▶ Multicontroller armrest options, advanced headland management on the **STEYR 700 Plus monitor** & autoguidance ready
- ▶ ISOBUS class II or III
- ▶ Available for EXPERT CVT only

Orange

Specifically designed for municipal applications

A practical and versatile solution, it's ideal for maintenance, mowing and public works where flexibility and reliability are essential. With options such as front PTO and mower brackets, it supports a wide range of tasks. Featuring a special color for visibility, **Orange** configuration ensures comfort, simplicity, and dependable performance for everyday operations.

»» FACTS

- ▶ Suspended front axle
- ▶ Fixed or suspended cab
- ▶ Front PTO
- ▶ Mower brackets
- ▶ Flexible options
- ▶ Available for EXPERT CVT and EXPERT **S-Control 8**

IT MAKES WORK ENJOYABLE

EXPERT comfort

The EXPERT leaves a great impression both inside and out. The spacious cab offers a work environment where anyone simply feels comfortable. That's not only because there are three seat variants to choose from, but also courtesy of the choice of armrests. The panorama roof window provides unobstructed visibility of the front loader.

EXPERT CVT CAB



A low mounted wiper increases the swept coverage area by 60% compared to previous models. Highlight in some way the visibility. It avoid also the dust accumulation vs the horizontal one.



Really good looking. At day and night

Perfect and unrestricted all round visibility – thanks to the 4-pillar panorama cab with its large windows, high-visibility roof window and one-piece front windscreen. The LED work light package assures superlative visibility even after night has fallen. Standard equipment comprises 6 LED work lights at the front of the roof, another 6 at the back of the roof, and 2 more LED work lights on the bonnet. An optional 4 LED work lights, one fitted low on each cab pillar, front and rear, are also available. The light intensity of 2,000 lumens per LED headlight turn night into day and ensure accurate, efficient work.

» FACTS

- ▶ Cab suspension
- ▶ Low noise level of just 69 dB(A)
- ▶ Automatic air-conditioning system
- ▶ Three driver seat options
- ▶ Up to 18 powerful LED worklights

OPERATE YOUR **EXPERT.** EXACTLY HOW YOU WANT

Thanks to the ergonomic Multicontroller armrest, you always have everything under control in the STEYR EXPERT. You can choose between two options: the tried-and-tested Multicontroller armrest, which can already be found in larger tractors, and the exclusively STEYR developed Multicontroller II armrest. But both have the same goal. To make your work as easy as possible.

Everything under control with the Multicontroller

In the comfortable EXPERT cockpit, you are in control. 12 freely programmable short cut menus allow quick access to key EXPERT functions on the STEYR 700 Plus monitor. Simple to access and even more convenient to set-up. At the centre of the STEYR Multicontroller armrest is the Intuitive Control Panel, a smart layout of key features that allows all drivers to get the best from the machine.

»» FACTS MULTICONTROLLER

- ▶ Ergonomic operation with Multicontroller
- ▶ Joystick and levers for operating auxiliary control units at front and rear
- ▶ PTO switch
- ▶ Eco-Drive™ control lever
- ▶ You can choose to have either one or 2 screens to monitor your work in the field
- ▶ STEYR 700 Plus monitor
- ▶ ISOBUS Aux-N
- ▶ Rotary control for hydraulic settings and possibility to manage up to 4 ElectroHydraulics remotes
- ▶ Available for EXPERT CVT and EXPERT **S-Control 8**



Multicontroller armrest

In order to monitor your work in the field the way you like it more, you can choose to have one or two screens in the cab: one on the armrest and the other on the monitor bracket.

Multicontroller II. Exclusively for you. Exclusively from STEYR

Ergonomic operation with Multicontroller Joystick and levers for operating auxiliary controls at front and rear. Possibility to control up to 2 mechanical and 2 electro-hydraulic remotes. PTO switch. ICP (Intuitive Control Panel). Eco-Drive control lever. Rotary control for hydraulic settings. ISOBUS Aux-N.

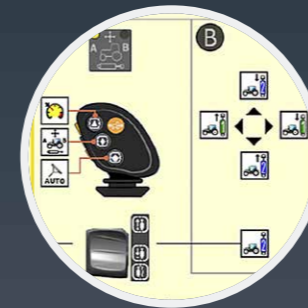

Freely configurable

Thanks to the Multicontroller-II armrest and STEYR 700 Plus monitor you have the possibility to configure three buttons on the Multicontroller as well as the buttons and axes of the joystick.



Front loader joystick

With three configurable buttons, PowerShuttle and speed controller.

»» FACTS MULTICONTROLLER II

- ▶ Configuration button of the screen on the joystick
- ▶ Electronic Front Hitch management available
- ▶ New monitor STEYR 700 Plus placed at the top of the cabin
- ▶ Branded armrest and exclusive features included
- ▶ Available for EXPERT CVT only





IT SIMPLY **OUTSHINES** EVERYTHING

The choice is yours

The EXPERT is available with two different cab variants. They all have, however, the spacious 4-pillar structure, an ergonomic design and a LED work light package with up to 18 LED work lights, each with 2,000 lumens that turn night into day.



Standard roof

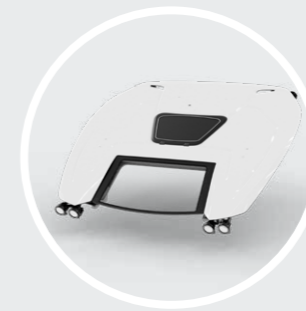

Panorama roof

» FACTS

- ▶ 4-pillar cab
- ▶ Two roof variants
- ▶ Panorama window
- ▶ Up to 18 LED work lights



A REAL, **POWER** HOUSE

Turbocharged four cylinder power

Tried and tested FPT Industrial 4-cylinder NEF 4.5 litre engines work away under the bonnet of the EXPERT, with a maximum output of 140 hp. Each model easily meets the requirements of the Stage V EU emissions standard thanks to the patented aftertreatment system, which is also fitted under the bonnet.



» FACTS

- ▶ 4-cylinder engines with turbocharger and intercooler
- ▶ 4.5 litre cubic capacity
- ▶ Rated power output: 100 – 130 hp.
Max. power output: 110 – 140 hp
- ▶ High maximum torque with up to 630 Nm
- ▶ HI-eSCR2 technology from FPT fullfills Stage V
- ▶ S-Tronic engine and transmission management
- ▶ Engine is fully compatible with hydro-treated vegetable oil, or HVO (bio-synthetic diesel)
- ▶ Up to 48% torque increase
- ▶ **Long engine service interval of 600 hours**
- ▶ Reversible fan
- ▶ Engine exhaust brake
- ▶ 180-litre fuel tank to help maximise the working day
- ▶ S-Stop II Brake-to-Clutch

Eco-Drive

The dual hand throttle allows the individual adjustment of the minimum and maximum engine speed, adjusting the vehicle characteristics according to the required task and minimizing fuel consumption.



1 Power mode

Pulling and transport

Full potential of the engine is available.

2 Eco mode

Pulling and transport economy

With the right hand throttle lever you can limit the maximum engine speed to save fuel.

3 PTO mode

Set the desired engine (PTO) speed with the left hand throttle lever. The right hand throttle lever determines the engine speed down to which the engine can be drooped, before the transmission reduces the ground speed.

COMFORT MEETS EFFICIENCY



S-Control CVT transmission

Maximum torque with minimum fuel consumption, electronic control that permits even faster changes in direction and active stationary control to stop safely on a steep gradient: the continuously variable S-Control CVT transmission is a leader in comfort and efficiency.



S-Tronic custom settings

Individually set-up your S-Control CVT transmission settings according to your operation.

»» FACTS

- ▶ Stepless from 0 to 40 kph
- ▶ 40 kph at reduced engine revs
- ▶ Two points of 100% mechanical efficiency
- ▶ Active hold control
- ▶ Kick-down functionality
- ▶ S-Tronic engine and transmission management
- ▶ CVT custom dynamics
 - Acceleration/deceleration
 - Shuttling speed
 - Drive pedal behavior
 - Engine torque response

THE NEW BENCHMARK

S-Control 8 transmission

The S-Control 8 is a state-of-the-art, three-range, eight-speed Powershift transmission featuring leading double clutch technology from STEYR, providing a total of 24 forward and 24 reverse speeds.

KEY FEATURES AND TECHNOLOGY

- ▶ **Dual clutch system**
The S-Control 8 is an 8-step transmission utilizing dual clutch technology
- ▶ **Controlled Powershuttle**
The front of the transmission has dedicated clutches for Forward and Reverse, ensuring a controlled powershuttle
- ▶ **Gear Modulation**
Four odd-numbered gears and one clutch are located on one shaft, while the four even-numbered gears and one clutch are on a second shaft. Power is seamlessly modulated between the two clutches; as one clutch disengages an odd gear, the second clutch engages the even gear ratio
- ▶ **Transmission Ranges**
 - Range One (0 – 10.7 kph): specifically designed for heavier draft work at low speeds
 - Range Two (4.3 – 18.1 kph): the main working range, covering nearly 90% of all field, grassland, and loader applications. It allows for work under full load without any torque disruption
 - Range Three (Road Travel): the transmission is designed to start in this range for faster transport operations. A skip-shift function allows for quick progression through the PowerShift speeds, saving time between fields

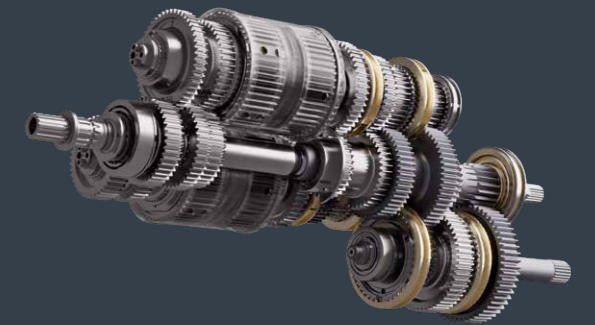

»» FACTS

- ▶ Smooth, efficient power delivery for maximum productivity in all conditions (24x24 with 8 gears and dual clutch technology)
- ▶ Perfect speed control for transport, field work, and ultra-low speeds during precision tasks (3 Ranges and Built-in Creeper)
- ▶ No loss of traction or efficiency when adjusting field speed (Uninterrupted power through every gear change)
- ▶ Precise loader control and stress-free operation (S-Stop Brake to Clutch function)



A MATCH FOR ANY TASK. ONE STEP **AHEAD**

Fully integrated

An expert leads the way: the multi-functional front-mounted hitch is integrated into the front axle support frame and offers, in addition to the powerful front hydraulics with a lifting capacity of up to 2,300 kg, also a PTO that can reach 1,000 rpm at an engine speed of just 1,895 rpm. Attaching an implement is made safer and easier via easy-to-access remote hitch and PTO switches, and once back in the seat the operator will find an excellent view to the implement. The new wet clutch for front PTO significantly improves performance and reliability while reducing noise emission.



FRONT PTO

- ▶ PTO perfectly integrated
- ▶ 1,000 rpm front PTO
- ▶ New wet clutch
- ▶ Front PTO-management
- ▶ Progressive soft start
- ▶ ElectroHydraulic engagement under load

FRONT LINKAGE

- ▶ 2,300 kg maximum lift capacity
- ▶ Seven-pin lighting and 40-A plug sockets fitted standard
- ▶ Electronic front implement damping available as an option (only on EXPERT CVT)

Implement and land protection

The optional front implement damping system protects implements as well as the land and noticeably improves the traction of the front axle. It is available in combination with the Multicontroller-II armrest. (only on EXPERT CVT)

Convenient hitching

The EXPERT remote operating switches for hitch operation to aid safe hitching.

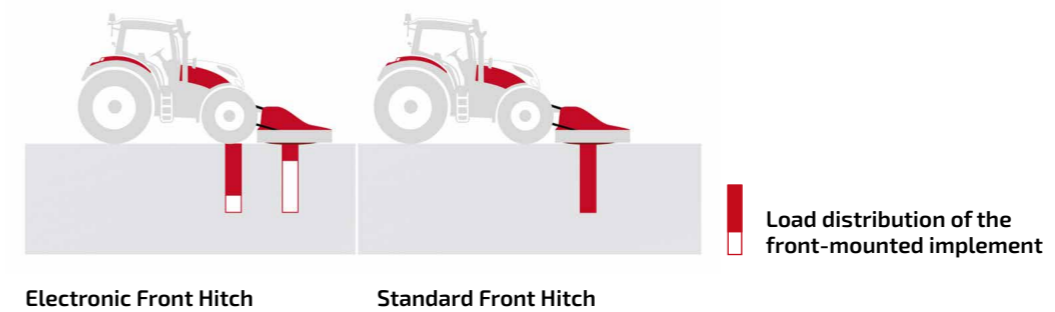

HEAVY TASKS? MAKE THEM **LIGHT WORK**

Always in good hands

Ready to meet any challenge: The new EXPERT is equipped as standard with a powerful CCLS hydraulic system that delivers a flow rate of 110 l/min. The robust rear hitch (Cat. II or III N) lifts up to 5,600 kg, making it possible to easily use heavy tillage equipment. Two mechanical remote valves are provided as standard, while the tractor's capabilities can be extended with mechanical, mixed or full electro-hydraulic remotes. Available configurations are: 3 or 4 mechanical, 2 mechanical and 2 electro-hydraulic, 3 or 4 electro-hydraulic. The rear PTO is available with two or three speeds.

REAR HITCH

- ▶ Up to 5,600 kg lifting capacity
- ▶ Improved top link fixing for better stability and position indicator
- ▶ CCLS hydraulic system with up to 110 l/min pump capacity
- ▶ Electronic Hitch Regulation (EHR)
- ▶ Ride Control – dynamic vibration damping
- ▶ Up to seven ElectroHydraulic remote valves (four on the rear, three centrally mounted)
- ▶ Power-Beyond connection
- ▶ Easy setup through STEYR 700 Plus monitor



Easy setup

Shortcut keys bring you directly to the settings menu to configure your Multicontroller handle.

Easy to reach

External controls on both fenders for easy implement connection.



REAR PTO

- ▶ ElectroHydraulic engagement under load
- ▶ PTO-Management
- ▶ Progressive soft start
- ▶ External controls on both rear fenders
- ▶ PTO with three speeds: 540/540E/1,000
- ▶ Ground speed PTO optional



THE **PERFECT MATCH** IS JUST IN FRONT OF YOU

The new STEYR S series front loaders

Whether you're working around the farm yard or in the fields, the new STEYR S front loader series is the perfect match to your tractor and the challenges you face in your day-to-day work. Offered with premium specifications, you have the choice among 20 models across two ranges, compatible with an output of 58 to 240 hp and can be customized to cover the multiple application required for powerful handling tasks.

The front loader mounting brackets and boom are perfectly designed to match your STEYR tractors, allowing easy access to all maintenance points without restricting your tractor's manoeuvrability.



Scan the QR-Code and get more information about STEYR S Series front loaders.

U Range

Versatility for everyday handling tasks

The versatile and durable U front loader range, with mechanical self-levelling, is ideal for everyday handling tasks. Easy-to-operate and robust, they are offered with the **FITLOCK 2+ System®** for quick hitching/unhitching and the **MACH System®** to safely connect all hydraulic and electrical lines. In addition, they feature an easy access to the 3rd function for implements requiring a hydraulic supply.

»» FACTS

- ▶ 4 models
- ▶ Lifting capacity: 2,151 to 2,848 kg
- ▶ Lifting height: 3.85 to 3.95 m
- ▶ With or without mechanical self-levelling
- ▶ Optional 4th function

T Range

Performances with no compromises

If you need extra performance, the T range is tailor made for the highest demands with enhanced comfort. Designed to perform heavy-duty operations, the T range is equipped with the PCH hydraulic self-levelling linkage, which allows a large crowd angle, up to 52° at ground level, and increases the lifting power by 35% without needing any additional energy input. Which results into more amount of material on the bucket and less transport.

»» FACTS

- ▶ 4 models
- ▶ Lifting capacity: 1,947 to 2,646 kg
- ▶ Lifting height: 3.85 to 3.95 m
- ▶ Hydraulic self-levelling PCM standard
- ▶ Hose and wiring harness are completely integrated in the boom and the crossbar



»» FEATURES

- ▶ **FITLOCK 2+ System**
- ▶ **MACH System**
- ▶ **SHOCK Eliminator**



»» FEATURES

- ▶ **FITLOCK 2+ System**
- ▶ **MACH System**
- ▶ **SHOCK Eliminator**
- ▶ **FAST-LOCK System®**
- ▶ **AUTO-UNLOAD System®**
- ▶ **MACH 2®**

SHOWCASING COMFORT

Excellent drive characteristics

What experts really want: power and comfort. The EXPERT combines these features like almost no other tractor in this power segment and always efficiently delivers up to 140 hp to the ground – whether working on soil, dirt tracks or asphalt.

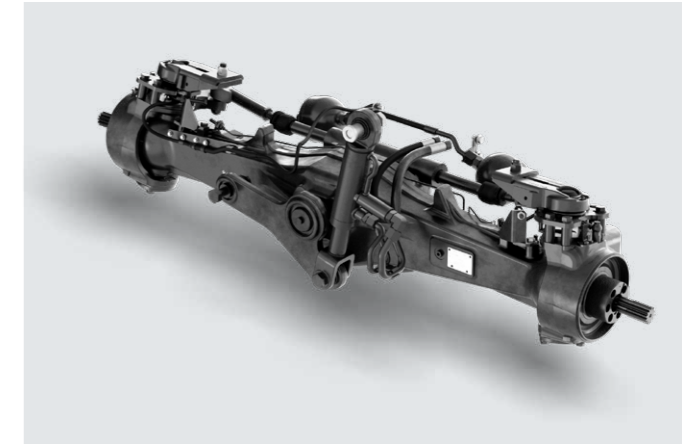

Suspended front axle. Rock & roll no more

Sharing the same renowned suspension concept as PROFI tractors, the EXPERT suspended front axle keeps the tractor chassis stabled and levelled. At the same time, it takes care of absorbing all the shocks that could be experienced during transport operations or when travelling with a heavy mounted implement. A manually operated switch allows the operator to raise/lower the tractor's front-end for added stability and comfort.



Automatic self-levelling for a smoother ride

Load-sensing automatic self-levelling and controlled damping, courtesy of an advanced accumulator and regenerative valve system, pave the way for a smoother ride. You can adjust suspension settings, choosing soft, normal or hard, by simply pressing a button on the control panel.

ADVANCED, **EASY TO USE** TECHNOLOGY AT YOUR FINGERTIPS

Up to 1.5 cm Track Precision

The automatic DGPS-based STEYR Guide integrated steering system assures parallel tramline guidance for work in straight lanes, on curves and in the headlands. With a precision of up to as little as 1.5 cm through an owned **comprehensive RTK+** network, there is no risk of overlapping even with tough ground or weather conditions.



Lower your operation's input costs with section control

The technology will automatically switch sections on/off in areas that have already been covered to avoid overlap on passes in field, at headland turns and irregular fields shapes. This lowers your operation's input costs by eliminating double applications of seed and fertiliser.



STEYR 700 Plus & ISOBUS

The STEYR 700 Plus touchscreen monitor offers an effective control and precision guidance system for arable farming. **ISOBUS Class II-compatible attachments plug in seamlessly and appear instantly on the Universal Terminal** – eliminating extra wiring and the need for an additional implement display.

FACTS

- ▶ Range of signal accuracies available (from sub meter to centimeter-level accuracy)
- ▶ Optional high accuracy RTK+ signal with accuracy levels close to 1.5 cm
- ▶ 12-inch STEYR 700 Plus monitor with responsive touchscreen
- ▶ **ISOBUS Class II & III compatible**
- ▶ STEYR Guide integrated automated steering system
- ▶ STEYR Turn II automates turns at the end of a row

KEEP YOUR FINGER ON THE PULSE OF YOUR **FARMING**



» FACTS

- ▶ User-friendly interface
- ▶ Time-saving management
- ▶ Data visualisation enhancing decision making
- ▶ Mixed-fleet data integration

STEYR FieldOps

Purposefully designed to be a simplified and streamlined all-in-one operations management solution, STEYR FieldOps will empower owners and operators to manage and visualize their multi-branded fleet at anytime from anywhere. Today, the EXPERT brings farmers the full STEYR FieldOps experience – enhanced by Connectivity Included, ensuring long-term access to all telematics and agronomic features as well as advanced connected services.

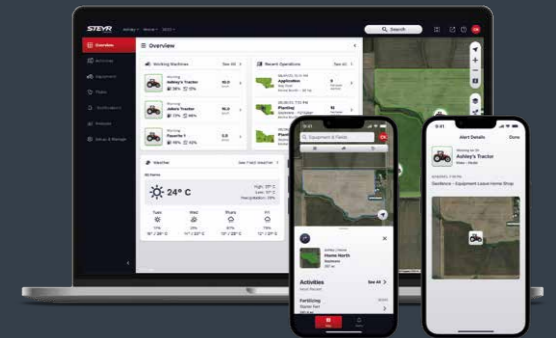

Keep an eye on your farm

- ▶ Crop and weather monitoring
- ▶ Operation control in real time

One simplified, comprehensive solution

The new all-in-one mobile app and web platform stores machines' information, providing one streamlined platform for all STEYR machines, equipment brands and users.

Keep an eye on your data

Access to near real-time data and insights, precise location and duty status, estimated job completion time, and more.



Keep an eye on everything

Download the FieldOps App and keep an eye on your operation anytime, anywhere! One place to manage all your tractors as well as your equipment and devices.

ALL IN ONE

Premium tractors deserve premium cares. STEYR products and services are available and operating 24/7. Now and ever.

STEYR Parts

Quality down to the last detail. STEYR Genuine Parts

Our certified Genuine Parts are designed for your STEYR tractor according to the exact specifications of our engineers and submitted to the most rigorous quality tests for conformity, robustness, safety and endurance. We work closely with our STEYR Dealers to ensure the availability and prompt deliveries, saving you lengthy downtimes.

The sustainable and affordable choice. STEYR Reman Parts

STEYR Reman Parts are remanufactured to the highest quality standards and come with a 2-year warranty. They are 100% reliable, cost on average 30% less and the remanufacturing process saves 80% energy compared to new products.

FLEETPRO™ Parts. Your alternative

The FLEETPRO parts range is designed for machines with low-intensity use and older models within your fleet, when it's important to operate safely within a limited budget. FLEETPRO parts come with a 1-year warranty.

Upgrade your tractor. STEYR Accessories

With our accessories and kits, you can improve and customize your STEYR tractor to your own requirements – add a fuel preheater, additional headlights, rear cameras, control units and much more for an exclusive and efficient result.

STEYR services

Technical support

STEYR Service experts, whether out in the field, at your dealer or on dedicated customer helplines, are ready to ensure quick and efficient solutions through their deep knowledge of STEYR equipment.

STEYR Premium Service

At STEYR, we are proud to offer our customers Premium Service, with 24/7 customer support whenever you need it. You can reach us at 080078397000. Working closely with our extensive STEYR dealer network, we provide a high level of customer care and respond promptly to all enquiries, whether for general information or field service support, to minimise potential downtime.

STEYR Warranty

STEYR Warranty is the Manufacturer Extended Warranty program developed to protect your investment from unpredictable repair costs. STEYR Warranty is an extension of the Manufacturer Standard Warranty (first year), designed to support you with:

- ▶ Manufacturer warranty and best possible coverage
- ▶ Higher residual value for your tractor
- ▶ Optimization of Total Cost of Ownership
- ▶ Enhanced profitability

STEYR Maintenance

Developed by STEYR to make it easier for our customers to manage long term routine maintenance, STEYR Maintenance is a professional and flexible planned maintenance programme, covering the planned maintenance operations up to 6,000 hours with flexible duration up to 5 years, depending on the type of machine and on your specific needs.

SPECIFICATIONS

MODEL	4110 EXPERT	4120 EXPERT	4130 EXPERT	4140 EXPERT
TRANSMISSION				
S-Control CVT Continuously variable transmission Driving speed* 0-40 kph	•	•	•	•
S-Control 8 24x24 (8 gear dual clutch technology)	•	•	•	•
ENGINE				
Common rail diesel engine with HI-eSCR2 technology, 16 valves, turbocharger and intercooler, fulfills emission standards Stage V Number of cylinders/Capacity [cm ³]	4/4,485	4/4,485	4/4,485	4/4,485
Max. engine power ECE R120 ¹⁾ [kW/hp]	81/110	74/100	88/120	81/110
Rated engine power ECE R120 ¹⁾ [kW/hp]	81/110	88/120	96/130	88/120
Engine speed at max. engine power [rpm]	1,700-1,900	2,200	1,700-1,900	2,200
Rated engine speed [rpm]	1,700-1,900	2,200	1,700-1,900	2,200
Max. torque [Nm @ 1,400 rpm]	520	551	610	630
Torque increase OECD [%]	48	44	46	41
Fuel tank Diesel/AdBlue® [l]	180/19	180/19	180/19	180/19
PTO	Shiftable with progressive electro-hydraulic engagement with soft start			
PTO speed [rpm] 540/540E/1,000	•	•	•	•
Engine speeds [rpm] 1,969/1,546/1,893	•	•	•	•
Stationary PTO	•	•	•	•
Front PTO* 1,000 @ 1,895 engine speed [rpm]	•	•	•	•
HYDRAULICS				
EHR hitch control with dynamic vibration damping Ride Control	•	•	•	•
Max. pump flow rate with pressure/volume control, load Sensing 110 L/min	•	•	•	•
Max. operating pressure [bar]	210	210	210	210
Max. lifting capacity through range [kg]	5,600	5,600	5,600	5,600
Remote valves	rear, up to 4 can be configured 2 mechanical/additional 2 mechanical or 2 electrical or full electrical 3 or 4 (only with Multicontroller armrest)	•/•	•/•	•/•
	midmounted, up to 3 electrical	•	•	•
Integrated front hitch* max. lifting capacity [kg]	2,300	2,300	2,300	2,300

MODEL	4110 EXPERT	4120 EXPERT	4130 EXPERT	4140 EXPERT
ALL-WHEEL DRIVE				
Engagement electro-hydraulic with traction management	•	•	•	•
FRONT AXLE STEERING				
Suspended front axle	•	•	•	•
Steering system Hydraulic, load-sensing system	•	•	•	•
Steering wheel Height- and tilt-adjustable	•	•	•	•
Steering angle Track width ²⁾ 1,830 mm [°]	55	55	55	55
Min. turning radius Track width ²⁾ 1,830 mm [m]	4.5	4.5	4.5	4.5
BRAKES				
Wet dual brake discs, hydraulically actuated	•	•	•	•
All-wheel brake with Opti-Stop	•	•	•	•
Two-line compressed air braking system	•	•	•	•
TYRES				
Maximum tyres³⁾	front	480/65R28	480/65R28	480/65R28
	rear	600/65R38	600/65R38	600/65R38
WEIGHT				
Approximate shipping weight* [kg]	5,500	5,500	5,500	5,500
Permissible total weight [kg]	8,800	8,800	8,800	8,800
DIMENSIONS²⁾				
Total length [mm]	4,784			
Min. – max. width [mm]	1890 – 2164			
Total height Standard roof/Low roof/Panorama roof [mm]	2,885/2,730/2,755			
Wheelbase [mm]	2,490			
Min. – max. track width front [mm]	1,446 – 2,154			
Min. – max. track width rear [mm]	1,530 – 2,138			

• Standard • Optional – Not available

*Depending on country-specific legislative requirements and specifications

¹⁾ ECE R120 complies with ISO 14396 and 97/68EC

²⁾ With standard tyres

³⁾ Other tyres available as special equipment on request (i.e. as cost options)



You drive better when you are safe. Before using this vehicle, please read the Operating Manual and become familiar with the use of each of the controls. Note the contents of the instruction panels and use the safety equipment for your own personal safety. This brochure is intended for use internationally. The availability of a few models and of standard and special equipment items may vary from one country to another.



STEYR reserves the right at any time and without prior announcement to make changes to the design and technical version without this in any way obliging STEYR to transfer these to units already sold.

Details, descriptions and pictorial material reflect the current status at the date of publication, but can be amended without prior announcement and at any time. Pictorial materials may show certain national versions, items of special equipment as well as non-complete standard versions.

BTS Adv. (Turin) - 02/26 - 26S0006_COMINB
www.steyr-traktoren.com

steyr-traktoren.com



STEYR
TRAKTOREN