

ORIGINAL INSTRUCTIONS

OPERATOR'S MANUAL

Workmaster™ 35

Workmaster™ 40

Compact Tractor

PIN LSM0W35RTP0014395 and after;

PIN LSM0W40RCP0014022 and after

Part number 92157413

1st edition English
November 2023



Contents

1 GENERAL INFORMATION

Note to the owner.....	1-1
Intended use.....	1-2
Electromagnetic Compatibility (EMC).....	1-4
Product identification plate.....	1-5
Product Identification Number (PIN) (ROPS).....	1-7
Operator's manual storage.....	1-8
Machine orientation.....	1-9
Emissions overview.....	1-10

2 SAFETY INFORMATION

Safety rules and signal word definitions.....	2-1
Safety rules.....	2-2
Do not operate tag.....	2-9
Roll Over Protective Structure (ROPS) frame - Personal safety.....	2-10
Ecology and the environment.....	2-11
Safety signs.....	2-12
Instructional signs.....	2-27
Safety features.....	2-35

3 CONTROLS AND INSTRUMENTS

Access to operator's platform

Access to operator's platform.....	3-1
------------------------------------	-----

Operator's seat

Seat belt.....	3-1
Mechanically - adjusted operator seat.....	3-2
Roll Over Protective Structure (ROPS).....	3-3

Forward controls

Instrument panel.....	3-5
Engine fault code display.....	3-9
Hydrostatic transmission - Operate.....	3-16
Shuttle lever.....	3-17
Clutch pedal.....	3-18
Brake pedal.....	3-19
Foot throttle pedal.....	3-20
Hand throttle lever.....	3-21
Horn switch (optional).....	3-22
Power Take-Off (PTO) switch.....	3-23
Key switch.....	3-24
Differential lock lever - Operating.....	3-25
Hydrostatic transmission pedal - Operating.....	3-26
Tilt steering lever - Operating.....	3-27

Multifunction light switch.....	3-28
Engine Speed Management (ESM) switch.....	3-28
Engine Speed Management (ESM) Up/Down switch.....	3-29
DPF switch.....	3-30

Left-hand side controls

Transmission range lever.....	3-31
Park brake.....	3-32
Four-Wheel Drive(4WD) lever.....	3-33
Mid Power Take-Off (PTO) (optional).....	3-34

Right-hand side controls

Hydraulic Power Lift (HPL).....	3-35
Rear remote control valve(s) - optional.....	3-36
Mid-mount control valve.....	3-38
Mechanical transmission lever.....	3-40

Exterior controls

Hood release latch.....	3-41
-------------------------	------

4 OPERATING INSTRUCTIONS

Commissioning the unit

Engine break-in procedure.....	4-1
Diesel Particulate Filter (DPF) regeneration.....	4-2
Engine speed management.....	4-7
Power Take-Off (PTO) operation.....	4-8
Three-point hitch.....	4-10
Attaching three-point equipment.....	4-11
Drawbar - Operating.....	4-14
Top link installation.....	4-15
Drop rate control valve.....	4-16

Starting the unit

Key switch - Operating.....	4-17
Glow plugs - Cold start aid.....	4-18
Starting the engine (Mechanical).....	4-19
Starting the engine (Hydrostatic transmission).....	4-22
Starting the engine with jumper cables.....	4-25

Stopping the unit

Stopping the engine.....	4-26
Emergency stopping the engine.....	4-27
Brakes.....	4-28

Moving the unit

Steering wheel - Adjust	4-30
Steering - Operation	4-31
Transmission - Warm-up	4-32
Hydrostatic transmission - Operation	4-33
Mechanical transmission external controls - Operation	4-35

Parking the unit

Parking the tractor	4-37
---------------------------	------

5 TRANSPORT OPERATIONS

Road transport

External lighting	5-1
Turn signal / Hazard lights - Identification	5-2
Turn signal / Hazard lights - Operation	5-3
Road lights - Operation	5-4
Work lights - Operation	5-5
Brakes and controls - Driving	5-6

Shipping transport

Transporting by truck or trailer	5-7
--	-----

Recovery transport

Brakes and controls - Towing	5-7
------------------------------------	-----

6 WORKING OPERATIONS

General information

Ballast	6-1
Ballast weight requirements	6-2
Liquid ballast	6-4

7 MAINTENANCE

General information

General information	7-1
General specification - Diesel fuel	7-3
General specification - Biodiesel fuels	7-4
Refueling the tractor	7-6
Change engine coolant to Organic Acid Technology (OAT) coolant	7-7
Fluids and lubricants	7-9
Capacities	7-10

Maintenance planning

Maintenance chart	7-11
-------------------------	------

Every 10 hours or daily

Engine oil level - Check	7-12
Engine cooling system - Check.....	7-14

After first 50 hours

Engine oil and oil filter - Change	7-15
Hydraulic oil filter - Replace	7-17
Hydrostatic transmission oil filter - Replace	7-18
Roll Over Protective Structure (ROPS) - Check	7-19
Wheels - Bolts and Nuts - Tighten.....	7-20
Fuel water separator filter - Replace	7-21

Every 50 hours

Grease fittings - Lubricate	7-22
Transmission fluid level - Check.....	7-24
Clutch pedal free play - Adjust	7-25
Brake pedal free play - Adjust	7-26
Hydrostatic Transmission (HST) neutral position - Check and Adjust.....	7-27
Tire inflation pressure - Check.....	7-30
Front axle and differential oil level - Check.....	7-32
Air cleaner - Clean - Primary element	7-33

Every 100 hours

Fuel filter - Drain.....	7-34
--------------------------	------

Every 300 hours

Engine oil and oil filter - Change	7-34
Oil filter - Replace	7-35
Hydrostatic Transmission (HST) oil filter - Replace - HST system	7-36
Wheel bolts and nuts - Check	7-37
Air cleaner primary element - Replace	7-38

Every 500 hours

Fuel filter water separator - Replace	7-39
---	------

Every 600 hours

Front axle and differential fluid - Change.....	7-42
Transmission fluid - Change.....	7-44

Every 1000 hours

Air cleaner inner element - Replace.....	7-45
--	------

Every 1500 hours

Engine coolant - Draining and flushing	7-45
--	------

General maintenance

Hydrostatic transmission (HST) neutral adjustment - Check	7-46
Engine belts - Adjust	7-47
Roll Over Protective Structure (ROPS) - Replace - Possible damage	7-48
Battery	7-49
Alternator	7-50
Headlight bulb - Replace	7-51
Turn signal/Hazard light bulb replacement	7-52
Flasher unit bulb - Replace	7-53
Wheels - Bolts and Nuts - Tighten	7-55
Front wheel toe-in - Adjust	7-56
Brake pedal free play - Adjust	7-57
Clutch pedal free play - Adjust	7-58

Fuse and relay locations

Fuse and relay locations	7-59
--------------------------------	------

Storage

Tractor storage	7-60
Removal of tractor from storage	7-61

8 TROUBLESHOOTING

Symptom(s)

Engine - Troubleshooting	8-1
Hydraulic Lift System - Troubleshooting	8-2
Steering - Troubleshooting	8-2
Hydrostatic transmission - Troubleshooting	8-3
Electrical system - Troubleshooting	8-3

9 SPECIFICATIONS

Tire inflation pressures	9-1
Rear wheel liquid ballast	9-2
General specification	9-3
Dimensions	9-8

10 ACCESSORIES

Accessories	10-1
-------------------	------

11 FORMS AND DECLARATIONS

Delivery report - owner copy	11-1
Delivery report - dealer copy	11-3

1 - GENERAL INFORMATION

Note to the owner

This manual contains information concerning the adjustment and maintenance of your new equipment. You have purchased a dependable machine, but only by proper care and operation can you expect to receive the performance and long service built into this equipment. Please have all operators read this manual carefully and keep it available for ready reference.

Your NEW HOLLAND dealer will instruct you in the general operation of your new equipment. (Refer to the 'Delivery Report' at the back of this manual.) Your dealer's staff of factory-trained service technicians will be glad to answer any questions that may arise regarding the operation of your machine. New Holland Top Service is also available. Call 1-866-NEWHLND (1-866-639-4563) or email na.topservice@cnh.com.

Your NEW HOLLAND dealer carries a complete line of genuine NEW HOLLAND service parts. These parts are manufactured and carefully inspected to insure high quality and accurate fitting of any necessary replacement parts. Be prepared to give your dealer the model and product identification number of your new equipment when ordering parts. Locate these numbers now and record them below. Refer to the 'General Information' section of this manual for the location of the model and product identification numbers of your machine.

PLEASE RECORD THE FOLLOWING INFORMATION

Model

Product Identification Number (PIN)

Engine number

Transmission number

Purchase date

	<p>This is the safety alert symbol. It is used with and without signal words to alert you to potential personal injury hazards. Obey all safety messages that follow this symbol to avoid possible death or injury.</p>
---	---

⚠ WARNING

**Illustrations in this manual may show protective shielding open or removed to better illustrate a particular feature or adjustment.
Replace all shields before operating the machine.
Failure to comply could result in death or serious injury.**

W0012A

ATTENTION: *The engine and fuel system on your machine is designed and built to government emission standards. Tampering by dealer, customers, operators, and end users is strictly prohibited by law. Failure to comply could result in government fines, rework charges, invalid warranty, legal action, and possible confiscation of the machine until rework to original condition is completed. Engine service and/or repairs must be done by a certified technician only!*

Improvements

CNH INDUSTRIAL AMERICA LLC is continually striving to improve its products. We reserve the right to make improvements or changes when it becomes practical and possible to do so, without incurring any obligation to make changes or additions to the equipment sold previously.

Intended use

⚠ WARNING

Roll-over hazard!

Always pull from the drawbar. DO NOT attach chains or ropes to the Roll Over Protective Structure (ROPS) for pulling purposes, as the machine could tip over. When driving through door openings or under low overhead objects, make sure there is sufficient clearance for the ROPS.

Failure to comply could result in death or serious injury.

W0463A

Your tractor is designed and made to pull, to carry, and to power a variety of mounted or towed equipment, although within some physical limits. The working speed and performance may depend on a number of various parameters, such as weather and terrain conditions. Though the tractor is designed to perform in combination with a variety of equipment in most crops and conditions, there may be a number of combinations of above parameters, for which there is severe degradation of performance of the tractor and/or its mounted or trailed equipment. If you notice degradation of performance, contact your dealer for assistance. He may have useful information for improvements, or a kit may be available to enhance the performance.

- Do not use the tractor for another purpose than intended by the manufacturer and outlined in this manual.
- Do not use the tractor beyond its limits of terrain gradient and stability as outlined further in this manual. Using the tractor beyond these limits may result in roll-over or tip-over. Observe the recommendations in this manual.
- Use only approved accessories and attachments that are designed for your machine. Consult your dealer on changes, additions or modifications that may be required for your machine. Do not make any unauthorized modifications to your machine.
- Do not use the tractor on higher speeds than allowed by the load and the environment. A wet surface or other low adherence conditions may increase the braking distance or result in vehicle instability. Always adapt your traveling speed according to the load of the vehicle and the characteristics of the road.
- Do not use the tractor near or on soft verges of canals and brooks or banks and verges that are undermined by rodents. The tractor may sink sideways and roll-over.
- Do not use the tractor on brittle bridge heads and poor bridge floors. These constructions may collapse and cause roll-over of the tractor. Always check out the condition and carrying capacity of bridges and ramps prior to engage.
- Do not use the tractor without wearing the seat restraint system during activities where roll-over or tip-over hazards exist. The Roll Over Protection Structure (ROPS) cab or ROPS structure will only be fully effective when the driver remains attached to his seat.
- Do not use equipment mounted on the tractor which is not correctly matching and firmly fixed. Such equipment may increase the risk for roll-over and hit the tractor when coming loose. Ensure that the dimensions of the three-point linkage interface of both the tractor and the equipment are matching according to the categories defined in ISO 730. Ensure that the dimensions and speed of the Power Take-Off (PTO) shaft on the tractors are matching those of the equipment.
- Do not use the tractor in combination with equipment, without having consulted the specific operator's manual provided with the equipment. The tractor is a universal tool to carry, tow, and drive a variety of equipment. This manual alone cannot provide you with all the information required for the safe operation of the combination.
- Do not use the tractor beyond its limits of dynamic stability. High speed, abrupt maneuvers, and fast and short cornering will increase the risk of roll-over.
- Do not use the tractor for pulling work, in cases where you do not know whether the load will yield, for instance when pulling stumps. The tractor may flip over when the stump is not yielding.
- Be cautious that the center of gravity of the tractor may increase when loads on the front-end loader or the three-point linkage are raised. In these conditions, the tractor may roll-over earlier than expected.
- Do not step down from the tractor without shutting down the PTO, shifting the transmission to park or neutral and applying the park brake, unless continued PTO operation is required for some equipment, such as pumps or wood chippers. The latter equipment may have an emergency stop device on the equipment itself, as human intervention is needed during operation. But other equipment, engaged and driven by the tractor will have no means to stop the power transmission, other than the PTO clutch of the tractor.
- You shall take the necessary precautions to always be aware of the possible presence of bystanders, certainly when maneuvering in confined areas, such as the farm yard and sheds. Keep people away from the tractor during work; ask bystanders to leave the field. There is not only the risk to be overrun by the tractor, but objects ejected by some

equipment mounted on the tractor, such as a rotary mower, may cause harm. Stones may be thrown further than the mowed crop. Pay the necessary attention while operating next to public roads or footpaths. Thrown objects can get projected outside the field and hit unprotected people like bikers or pedestrians. Wait to cut the edge of the field till it is clear of bystanders.

- Do not allow riders on the tractor; do not allow people standing on the access way or step to the cab when the tractor is moving. Your view to the left will be obstructed and a rider risks to fall from the tractor during unforeseen or abrupt movements.
- Always stay clear from implements operating area and especially do not stand between tractor and trailed vehicle either three-point linkage when operating lift controls; ensure no bystanders are near these operating areas.
- Your tractor may be equipped with a number of sensors to control safety functions. Tripping these sensors will result in a safe operation mode. Do not attempt to bypass any function on the tractor. You will be exposed to serious hazards, and moreover, the behavior of the tractor may become unpredictable.
- A tractor has only one operator station and is a one man operated vehicle. Other people on or around the tractor during normal operation are not allowed.
- All persons who will be operating this machine shall possess a valid local vehicle operating permit and/or other applicable local age work permits.
- The machine is designed and produced exclusively for agricultural use.
- The machine is not designed for light/heavy forestry applications; usage is prohibited for forestry applications.
- All other use will be considered to be contrary to the use specified by CNH INDUSTRIAL AMERICA LLC, who cannot be held liable for damage to property or the machine, or for personal injuries which may result.
- Persons who risk improper use will therefore assume the responsibility for any consequences arising from such use.
- Compliance with the instructions for use, maintenance and repairs described in this manual, are the essential pre-conditions for the use specified by CNH INDUSTRIAL AMERICA LLC.
- The machine must only be used, serviced, or repaired by personnel trained in the relevant working methods and safety regulations and who have been authorized to work on the machine.
- The engine and fuel system on your machine is designed and built to government emissions standards. Tampering by dealer, customers, operators and users is strictly prohibited by law. Failure to comply could result in government fines, rework charges, invalid warranty, legal action and possible confiscation of the machine until rework to original condition is completed. Engine service and/or repairs must be done by a certified technician only!
- The user must also observe the rules concerning general safety and accident prevention, including the Highway Code when driving on public highways.
- Any arbitrary modifications made to this machine will release CNH INDUSTRIAL AMERICA LLC from any liability resulting from damage or injury.
- CNH INDUSTRIAL AMERICA LLC and all its distribution organizations, inclusive of, but not restricted to, national, regional, or local distributors, cannot be held liable for damage resulting from the malfunction of parts and/or components not approved by CNH INDUSTRIAL AMERICA LLC.
- Under no circumstances will a guarantee be issued for products made or sold by CNH INDUSTRIAL AMERICA LLC that are damaged as a result of the malfunction of parts and/or components not approved by CNH INDUSTRIAL AMERICA LLC.

Electromagnetic Compatibility (EMC)

Interference may arise as a result of add-on equipment that may not necessarily meet the required standards. As such interference can result in serious malfunction of the unit and/or create unsafe situations, you must observe the following:

- The maximum power of emission equipment (radio, telephones, etc.) must not exceed the limits imposed by the national authorities of the country where you use the machine
- The electro-magnetic field generated by the add-on system should not exceed **24 V/m** at any time and at any location in the proximity of electronic components
- The add-on equipment must not interfere with the functioning of the on board electronics

Failure to comply with these rules will render the NEW HOLLAND warranty null and void.

Product identification plate

The numbers on the Product Identification Number (PIN) plate are important in the event your tractor should require future service. Record the PIN in the section provided on page 1-1.

NOTE: Image for reference only .

The PIN plate (1) is located on the right-hand side of the front frame.

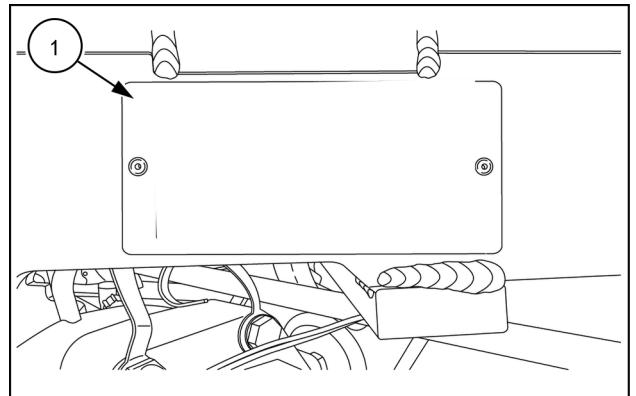

NHIL18CT00031AA 1

NOTE: Image for reference only .

The emissions information plate (2) is located on the left-hand side of the engine crankcase.

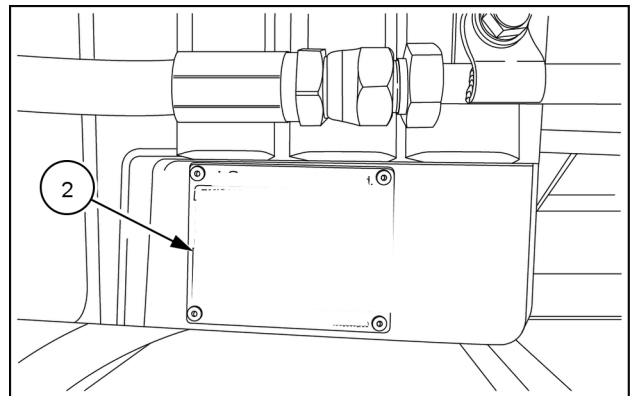

NHIL16CT00707AA 2

Running hours

- When requesting service or parts from your dealer, the dealer may ask you to provide the running hours displayed on the instrument panel.
- Hour meter and engine diagnosis error code (33) (See **Instrument cluster - Identification**)

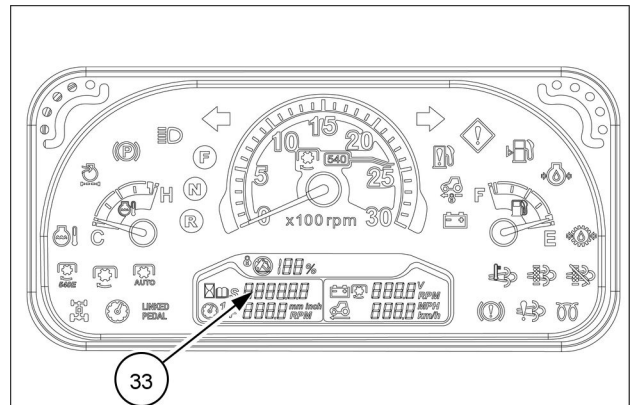

NHIL20CT00089FA 3

1 - GENERAL INFORMATION

The transmission identification numbers **(3)** are located on the transmission housing, to the left of the Hydraulic Power Lift (HPL). The transmission identification numbers are also located on the PIN plate.

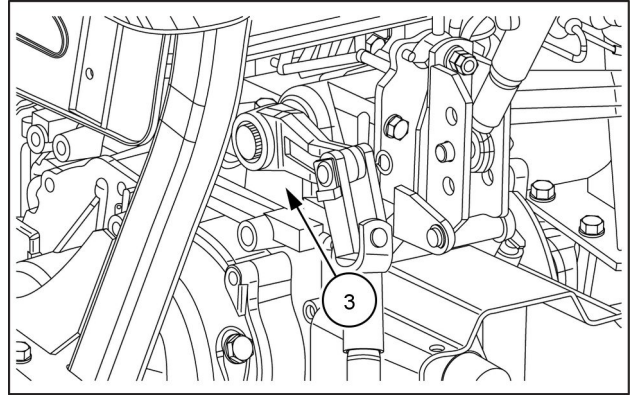

NHIL16CT00383AA 4

The engine identification number is located on the right-hand side of the engine block, below and inboard of the Exhaust Gas Recirculation (EGR) cooler. The engine identification number is also located on the PIN plate.

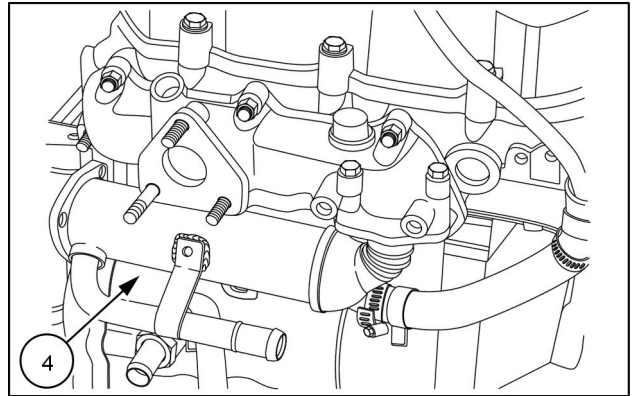

NHIL16CT00674AA 5

Product Identification Number (PIN) (ROPS)

The Roll Over Protective Structure (ROPS) PIN plate (1), is located on the right-hand side of the ROPS connector plate (1).

ROPS MODEL		MT240ERFI	
S/N			
TRACTOR MODEL		WORKMASTER 35, 40	
MANUFACTURER		LS Mtron Ltd.	ISO 5700:2013
		Made In Wanju, S. Korea	

4053405300 1

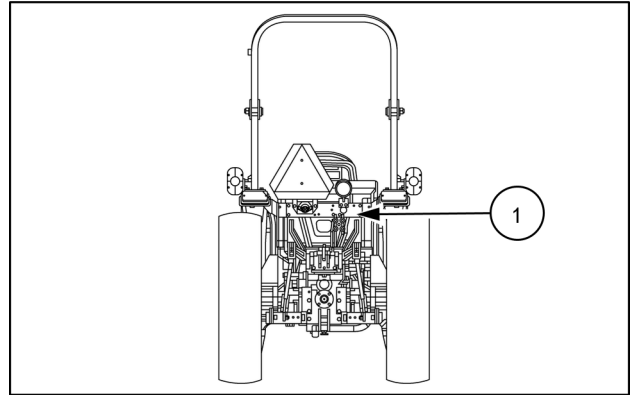

NHIL23CT00448AA 2

Operator's manual storage

The operator's manual must be stored in a secure place prior to operation and it must be kept available for use by all operators.

NOTE: *There is not a designated manual storage area on the tractor.*

Machine orientation

NOTE: On this equipment, left-hand and right-hand are determined by standing behind the unit, looking in the direction of travel.

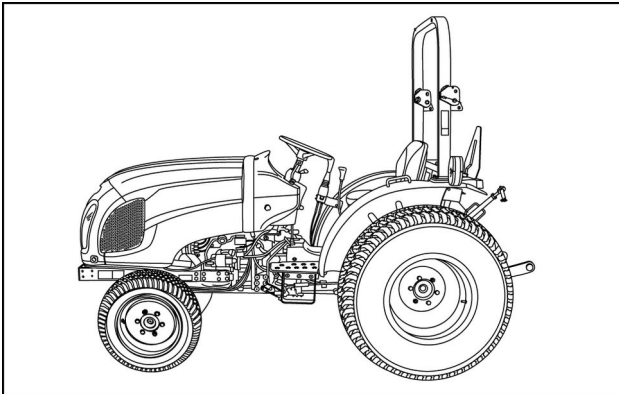

NHIL15CT00344AA 1

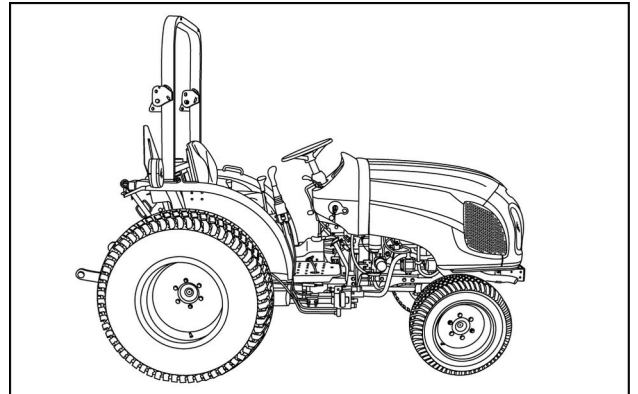

NHIL15CT00346AA 2

Left-hand view

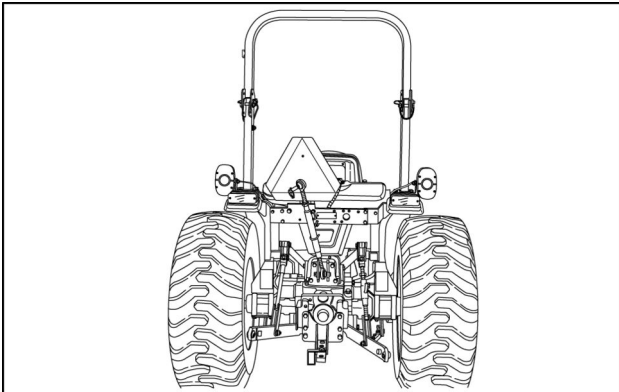

NHIL12CT00671AA 3

Right-hand view

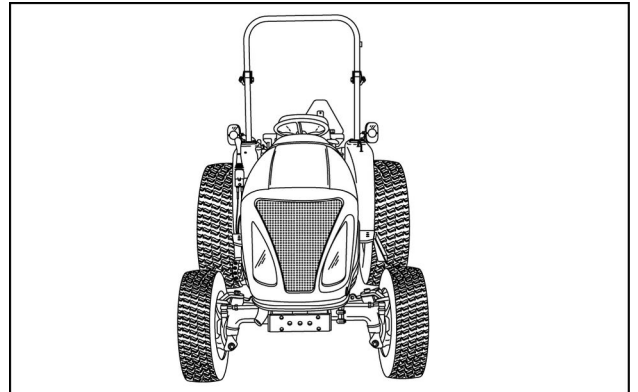

NHIL15CT00345AA 4

Rear view

Front view

Emissions overview

FEDERAL and CALIFORNIA EMISSION CONTROL SYSTEM WARRANTY STATEMENT

Your warranty rights and obligations

The California Air Resources Board (CARB), U.S. Environmental Protection Agency (EPA), and LS Mtron Ltd. (LS Mtron) are pleased to explain the emission control system warranty on your 2017-2018 model year engine. New engines must be designed, built and equipped to meet stringent anti-smog standards. LS Mtron must warrant the emission control system on your engine for the periods of time listed below provided there has been no abuse, neglect or improper maintenance or usage of your engine. Additional conditions and responsibilities are further outlined below. Where a warrantable condition exists, LS Mtron will repair your engine at no cost to you including diagnosis, parts and labor.

MANUFACTURER'S LIMITED WARRANTY COVERAGE:

LS Mtron warrants to the original owner, and to each subsequent owner of a new diesel engine, that the emission control system of your engine:

1. Was designed, built and equipped so as to conform at the time of sale with all applicable regulations of CARB and EPA.
2. Is free from defects in material and workmanship which will cause such engine to fail to conform with applicable regulations for the following warranty period:
 - o For engines rated at or above **19 kW (25 Hp)**: five (5) years or 3,000 hours of operation, whichever occurs first.

The warranty period shall begin:

- On the date the equipment is first delivered to the first retail purchaser, or;
- If the equipment is placed in service for demonstration purposes prior to sale at retail, on the date the engine is first placed in service.

The emission control systems of your new LS Mtron engine were designed, built and tested using genuine LS Mtron parts, and the engine is certified as being in conformity with CARB and EPA emission control regulations. Accordingly, it is recommended that any replacement parts used for maintenance, repair, or replacement of emission control systems must be LS Mtron parts. Any replacement part may be used in the performance of any maintenance or repairs and will be provided without charge to the owner, although LS Mtron recommends that the owner obtain assurance that such parts are warranted by their manufacturer and LS Mtron to be equivalent to genuine LS Mtron parts. Such use shall not reduce the warranty obligations of LS Mtron, provided they are warranted to be equivalent to genuine LS Mtron parts.

Any warranted part which is not scheduled for replacement as required maintenance shall be warranted for the warranty period defined above. If any such part fails during the period of warranty coverage, and provided that there has been no abuse, neglect or improper maintenance or usage of your engine, it will be repaired or replaced under warranty. Any such part repaired or replaced under the warranty shall be warranted for the remaining warranty period.

Any warranted part which is scheduled only for regular inspection in the written instructions shall be warranted for the warranty period defined above, provided that there has been no abuse, neglect or improper maintenance or usage of your engine. A statement in the written instructions to the effect of "repair or replace as necessary" shall not reduce the period of warranty coverage. Any such part repaired or replaced under warranty shall be warranted for the remaining warranty period.

Any warranted part which is scheduled for replacement as required maintenance shall be warranted for the period of time prior to the first scheduled replacement point for that part. If the part fails prior to the first scheduled replacement, the part shall be repaired or replaced by LS Mtron under warranty, provided that there has been no abuse, neglect or improper maintenance or usage of your engine. Any such part repaired or replaced under warranty shall be warranted for the remainder of the period prior to the first scheduled replacement point for the part.

LS Mtron provides warranty services or repairs at all manufacturer distribution centers (warranty stations) that are franchised to service the subject engines. Please see the Customer Assistance section of this statement for help in locating such service centers. Repair or replacement of any warranted part under warranty shall be performed at no charge to the owner at a warranty station.

The owner will not be charged for diagnostic labor that leads to the determination that a warranted part is in fact defective, provided that such diagnostic work is performed at a warranty station.

LS Mtron is liable for damages to other engine components proximately caused by a failure under warranty of any warranted part.

LS Mtron is required by California regulations to maintain a supply of warranted parts sufficient to meet the expected demand for such parts during the warranty period for the engines covered by this warranty.

OWNER'S WARRANTY RESPONSIBILITIES:

This engine is designed to operate on ultra low sulfur diesel fuel only. Use of any other fuel may result in this engine no longer operating in compliance with CARB or EPA's emissions requirements.

The purchaser is responsible for initiating the warranty process. You must present the engine to a LS Mtron dealer as soon as a problem exists. The warranty repairs should be completed by the dealer as expeditiously as possible.

Use of any add-on or modified parts that are not exempted from anti-tampering laws by CARB or EPA may reduce or eliminate your warranty coverage. The use of any non-exempted add-on or modified parts shall be grounds for disallowing a warranty claim. LS Mtron is not liable for failures of warranted parts caused by the use of a non-exempted add-on or modified part.

The emissions control parts covered by this Limited Emission Control System Warranty are listed under "What is covered by the Limited Emission Control System Warranty." You are responsible for the performance of all scheduled maintenance or repairs on your new LS Mtron engine. LS Mtron may deny a warranty claim if failure to perform maintenance results in the failure of a warranted part. Receipts covering the performance of regular maintenance should be retained in the event of questions arise concerning maintenance. The receipts should be transferred to each subsequent owner of the equipment with the emission warranted engines.

Customer Assistance

LS Mtron Ltd.
886, Gwahak-Ro, Bongdong-Eup
Wanju-gun, Jeollabuk-Do, Korea
Phone: 82-63-279-5824
Fax: 82-63-279-5933

CNH America LLC
Matt Fraiser
1919 Williams St
San Leandro, CA 94577
Phone : 1-510-351-2015
Fax: 1-510-357-2546

CNH America LLC
Andrew Jonik
200 George Delp Rd
New Holland, PA 17557
Phone : 1-717-355-1121
Fax : 1-717-355-1706

What is not covered by the Limited Emission Control System Warranty

This warranty does not cover:

1. Malfunctions in any part caused by any of the following: misuse, abuse, improper adjustments, modifications, alteration, tampering, disconnection, improper or inadequate maintenance, or use of fuels not recommended for the engine as described in the Maintenance Manual.
2. Damage resulting from accident, acts of nature or other events beyond the control of LS Mtron.
3. The replacement of expendable maintenance items such as exhaust system, filters, hoses, belts, oil, thermostat, and coolant made in connection with scheduled maintenance services once these parts have been replaced.
4. Replacement items which are not genuine LS Mtron parts or not authorized by LS Mtron.
5. Loss of time, inconvenience, loss of use of equipment, engine or commercial loss.

What is covered by the Limited Emission Control System Warranty

The following is a list of systems and parts that are considered a part of the Emission Control System and are covered by the Limited Emission Control System Warranty for engines which were built to conform to CARB and EPA regulations:

IMPORTANT! This may not include expendable maintenance items such as nozzle assemblies and rubber flanges. Emission related parts requiring scheduled maintenance are warranted until their first scheduled replacement point only.

This Limited Emission Control System Warranty applies to the following emission control parts:

1. Fuel System
 - A. Fuel injection pump.
 - B. Fuel Injectors.
2. Air Induction System
 - A. Intake manifold.
 - B. Turbocharger
 - C. Air Control Valve
 - D. Exhaust Manifold
3. Exhaust Gas Recirculation (EGR) System
 - A. EGR valve body
4. Aftertreatment Devices
 - A. Diesel Oxidation Catalyst (DOC)
 - B. Diesel Particulate Filter (DPF)
5. Positive Crankcase Ventilation (PCV) System.
 - A. PCV Valve.
 - B. Oil Filler Cap.
6. Miscellaneous items Used in Above Systems
 - A. Vacuum, temperature, and time sensitive valves and switches.
 - B. Electronic control units, sensors, solenoids, and wiring harnesses.
 - C. Hoses, belts, connectors, assemblies, clamps, fittings, tubing, sealing gaskets or devices, and mounting hardware.
 - D. Pulleys, belts and idlers.
 - E. Emission Control Information Labels.
 - F. Any other part with the primary purpose of reducing emissions or that can increase emissions during failure without significantly degrading engine performance.

2 - SAFETY INFORMATION

Safety rules and signal word definitions

Personal safety



This is the safety alert symbol. It is used to alert you to potential personal injury hazards. Obey all safety messages that follow this symbol to avoid possible death or injury.

Throughout this manual and on machine safety signs, you will find the signal words DANGER, WARNING, and CAUTION followed by special instructions. These precautions are intended for the personal safety of you and those working with you.

Read and understand all the safety messages in this manual before you operate or service the machine.

! DANGER indicates a hazardous situation that, if not avoided, will result in death or serious injury. The color associated with DANGER is RED.

! WARNING indicates a hazardous situation that, if not avoided, could result in death or serious injury. The color associated with WARNING is ORANGE.

! CAUTION indicates a hazardous situation that, if not avoided, could result in minor or moderate injury. The color associated with CAUTION is YELLOW.

FAILURE TO FOLLOW DANGER, WARNING, AND CAUTION MESSAGES COULD RESULT IN DEATH OR SERIOUS INJURY.

Machine safety

NOTICE: Notice indicates a situation that, if not avoided, could result in machine damage or property damage. The color associated with Notice is BLUE.

Throughout this manual you will find the signal word Notice followed by special instructions to prevent machine damage or property damage. The word Notice is used to address practices not related to personal safety.

Information

NOTE: Note indicates additional information that clarifies steps, procedures, or other information in this manual.

Throughout this manual you will find the word Note followed by additional information about a step, procedure, or other information in the manual. The word Note is not intended to address personal safety or property damage.

Safety rules

General safety rules

Use caution when you operate the machine on slopes. Raised equipment, full tanks and other loads will change the center of gravity of the machine. The machine can tip or roll over when near ditches and embankments or uneven surfaces.

Never permit anyone other than the operator to ride on the machine.

Never operate the machine under the influence of alcohol or drugs, or while you are otherwise impaired.

When digging or using ground-engaging attachments, be aware of buried cables. Contact local utilities to determine the locations of services.

Pay attention to overhead power lines and hanging obstacles. High voltage lines may require significant clearance for safety.

Hydraulic oil or diesel fuel leaking under pressure can penetrate the skin, causing serious injury or infection.

- DO NOT use your hand to check for leaks. Use a piece of cardboard or paper.
- Stop the engine, remove the key, and relieve the pressure before you connect or disconnect fluid lines.
- Make sure that all components are in good condition. Tighten all connections before you start the engine or pressurize the system.
- If hydraulic fluid or diesel fuel penetrates the skin, seek medical attention immediately.
- Continuous long term contact with hydraulic fluid may cause skin cancer. Avoid long term contact and wash the skin promptly with soap and water.

Keep clear of moving parts. Loose clothing, jewelry, watches, long hair, and other loose or hanging items can become entangled in moving parts.

Wear protective equipment when appropriate.

DO NOT attempt to remove material from any part of the machine while it is being operated or while components are in motion.

Make sure that all guards and shields are in good condition and properly installed before you operate the machine. Never operate the machine with shields removed. Always close access doors or panels before you operate the machine.

Dirty or slippery steps, ladders, walkways, and platforms can cause falls. Make sure these surfaces remain clean and clear of debris.

A person or pet within the operating area of a machine can be struck or crushed by the machine or its equipment. DO NOT allow anyone to enter the work area.

Raised equipment and/or loads can fall unexpectedly and crush persons underneath. Never allow anyone to enter the area underneath raised equipment during operation.

Never operate the engine in enclosed spaces as harmful exhaust gases may build up.

Before you start the machine, be sure that all controls are in neutral or park lock position.

Start the engine only from the operator's seat. If you bypass the safety start switch, the engine can start with the transmission in gear. Do not connect or short across terminals on the starter solenoid. Attach jumper cables as described in the manual. Starting in gear may cause death or serious injury.

Always keep windows, mirrors, all lighting, and Slow-Moving Vehicle (SMV) emblem clean to provide the best possible visibility while you operate the machine.

Operate controls only when seated in the operator's seat, except for those controls expressly intended for use from other locations.

Before you leave the machine:

1. Park the machine on a firm, level surface.
2. Put all controls in neutral or park lock position.
3. Engage the parking brake. Use wheel chocks if required.
4. Lower all hydraulic equipment — Implements, header, etc.
5. Turn off the engine and remove the key.

When, due to exceptional circumstances, you would decide to keep the engine running after you leave the operator's station, then you must follow these precautions:

1. Bring the engine to low idle speed.
2. Disengage all drive systems.

3. **⚠ WARNING**

**Some components may continue to run down after you disengage drive systems.
Make sure all drive systems are fully disengaged.
Failure to comply could result in death or serious injury.**

W0113A

Shift the transmission into neutral.

4. Apply the parking brake.

⚠ General maintenance safety ⚠

Keep the area used for servicing the machine clean and dry. Clean up spilled fluids.

Service the machine on a firm, level surface.

Install guards and shields after you service the machine.

Close all access doors and install all panels after servicing the machine.

Do not attempt to clean, lubricate, clear obstructions, or make adjustments to the machine while it is in motion or while the engine is running.

Always make sure that working area is clear of tools, parts, other persons and pets before you start operating the machine.

Unsupported hydraulic cylinders can lose pressure and drop the equipment, causing a crushing hazard. Do not leave equipment in a raised position while parked or during service, unless the equipment is securely supported.

Jack or lift the machine only at jack or lift points indicated in this manual.

Incorrect towing procedures can cause accidents. When you tow a disabled machine follow the procedure in this manual. Use only rigid tow bars.

Stop the engine, remove the key, and relieve pressure before you connect or disconnect fluid lines.

Stop the engine and remove the key before you connect or disconnect electrical connections.

Scalding can result from incorrect removal of coolant caps. Cooling systems operate under pressure. Hot coolant can spray out if you remove a cap while the system is hot. Allow the system to cool before you remove the cap. When you remove the cap, turn it slowly to allow pressure to escape before you completely remove the cap.

Replace damaged or worn tubes, hoses, electrical wiring, etc.

The engine, transmission, exhaust components, and hydraulic lines may become hot during operation. Take care when you service such components. Allow surfaces to cool before you handle or disconnect hot components. Wear protective equipment when appropriate.

When welding, follow the instructions in the manual. Always disconnect the battery before you weld on the machine. Always wash your hands after you handle battery components.

⚠️ Wheels and tires ⚠️

Make sure that tires are correctly inflated. Do not exceed any recommended load or pressure. Follow the instructions in the manual for proper tire inflation.

Tires are heavy. Handling tires without proper equipment could cause death or serious injury.

Never weld on a wheel with a tire installed. Always remove the tire completely from the wheel prior to welding.

Always have a qualified tire technician service the tires and wheels. If a tire has lost all pressure, take the tire and wheel to a tire shop or your dealer for service. Explosive separation of the tire can cause serious injury.

DO NOT weld to a wheel or rim until the tire is completely removed. Inflated tires can generate a gas mixture with the air that can be ignited by high temperatures from welding procedures performed on the wheel or rim. Removing the air or loosening the tire on the rim (breaking the bead) will NOT eliminate the hazard. This condition can exist whether tires are inflated or deflated. The tire MUST be completely removed from the wheel or rim prior to welding the wheel or rim.

⚠️ Driving on public roads and general transportation safety ⚠️

Comply with local laws and regulations.

Use appropriate lighting to meet local regulations.

Make sure that the SMV emblem is visible.

Make sure that the brake pedal latch is engaged. You must lock brake pedals together for road travel.

Use safety chains for trailed equipment when safety chains are provided with machine or equipment.

Lift implements and attachments high enough above ground to prevent accidental contact with road.

When you transport equipment or a machine on a transport trailer, make sure that it is properly secured. Be sure the SMV on the equipment or machine is covered while being transported on a trailer.

Be aware of overhead structures or power lines and make sure that the machine and/or attachments can pass safely under.

Travel speed should be such that you maintain complete control and machine stability at all times.

Slow down and signal before turning.

Pull over to allow faster traffic to pass.

Follow correct towing procedure for equipment with or without brakes.

⚠️ Fire and explosion prevention ⚠️

Fuel or oil that is leaked or spilled on hot surfaces or electrical components can cause a fire.

Crop materials, trash, debris, bird nests, or flammable material can ignite on hot surfaces.

Always have a fire extinguisher on or near the machine.

Make sure that the fire extinguisher(s) is maintained and serviced according to the manufacturer's instructions.

At least once each day and at the end of the day, remove all trash and debris from the machine especially around hot components such as the engine, transmission, exhaust, battery, etc. More frequent cleaning of your machine may be necessary depending on the operating environment and conditions.

At least once each day, remove debris accumulation around moving components such as bearings, pulleys, belts, gears, cleaning fans, etc. More frequent cleaning of your machine may be necessary depending on the operating environment and conditions.

Inspect the electrical system for loose connections and frayed insulation. Repair or replace loose or damaged parts.

Do not store oily rags or other flammable material on the machine.

Do not weld or flame cut any items that contain flammable material. Clean items thoroughly with non-flammable solvents before welding or flame-cutting.

Do not expose the machine to flames, burning brush, or explosives.

Promptly investigate any unusual smells or odors that may occur during operation of the machine.

General battery safety

Always wear eye protection when you work with batteries.

Do not create sparks or have open flame near a battery.

Ventilate the area when you charge a battery or use a battery in an enclosed area.

Disconnect the negative (-) terminal first and reconnect the negative (-) terminal last.

When you weld on the machine, disconnect both terminals of the battery.

Do not weld, grind, or smoke near a battery.

When you use auxiliary batteries or connect jumper cables to start the engine, use the procedure shown in the operator's manual. Do not short across terminals.

Follow the manufacturer's instructions when you store and handle batteries.

Battery post, terminals, and related accessories contain lead and lead compounds. Wash hands after handling. This is a California Proposition 65 warning.

Battery acid causes burns. Batteries contain sulfuric acid. Avoid contact with skin, eyes, or clothing. Antidote (external): Flush with water. Antidote (eyes): flush with water for 15 minutes and seek medical attention immediately. Antidote (internal): Drink large quantities of water or milk. Do not induce vomiting. Seek medical attention immediately.

Operator presence system

Your machine is equipped with an operator presence system to prevent the use of some features while the operator is not in the operator's seat.

Never disconnect or bypass the operator presence system.

If the operator presence system is inoperable, then it must be repaired.

Power Take-Off (PTO)

PTO-driven machinery can cause death or serious injury. Before you work on or near the PTO shaft or service or clear the driven machine, put the PTO lever in the disengage position, stop the engine, and remove the key.

Whenever a PTO is in operation, a guard must be in place to prevent death or injury to the operator or bystanders.

When doing stationary PTO work, keep clear of all moving parts and make sure that appropriate guards are in place.

Never use a spline adaptor:

- Match the right tractor PTO spline and speed with the PTO driveshaft provided with an implement. This will assure proper geometry and operating speed.
- Never operate **540 RPM** implements at **1000 RPM**.
- Never operate **1000 RPM** implements at **540 RPM**.
- Use of PTO adaptors will void the warranty of the driveshaft, and the PTO drive train of the machine and implement.

- For correct hitch geometry, refer to the operator's manual for each implement you connect.

Reflectors and warning lights

You must use flashing amber warning lights when you operate equipment on public roads.

Seat belts

Seat belts must be worn at all times.

Seat belt inspection and maintenance:

- Keep seat belts in good condition.
- Keep sharp edges and items that can cause damage away from the belts.
- Periodically check belts, buckles, retractors, tethers, slack take-up system, and mounting bolts for damage and wear.
- Replace all parts that have damage or wear.
- Replace belts that have cuts that can make the belt weak.
- Check that bolts are tight on the seat bracket or mounting.
- If the belt is attached to the seat, make sure that the seat or seat brackets are mounted securely.
- Keep seat belts clean and dry.
- Clean belts only with soap solution and warm water.
- Do not use bleach or dye on the belts because this can make the belts weak.

Operator protective structure

Your machine is equipped with an operator protective structure, such as: a Roll Over Protective Structure (ROPS), Falling Objects Protective Structure (FOPS), or a cab with a ROPS. A ROPS may be a can frame or a two-posted or four-posted structure used for the protection of the operator to minimize the possibility of serious injury. The mounting structure and fasteners forming the mounting connection with the machine are part of the ROPS.

The protective structure is a special safety component of your machine.

DO NOT attach any device to the protective structure for pulling purposes. DO NOT drill holes to the protective structure.

The protective structure and interconnecting components are a certified system. Any damage, fire, corrosion, or modification will weaken the structure and reduce your protection. If this occurs, THE PROTECTIVE STRUCTURE MUST BE REPLACED so that it will provide the same protection as a new protective structure. Contact your dealer for protective structure inspection and replacement.

After an accident, fire, tip over, or roll over, the following MUST be performed by a qualified technician before returning the machine to field or job-site operations:

- The protective structure MUST BE REPLACED.
- The mounting or suspension for the protective structure, operator's seat and suspension, seat belts and mounting components, and wiring within the operator's protective system MUST be carefully inspected for damage.
- All damaged parts MUST BE REPLACED.

DO NOT WELD, DRILL HOLES, ATTEMPT TO STRAIGHTEN, OR REPAIR THE PROTECTIVE STRUCTURE. MODIFICATION IN ANY WAY CAN REDUCE THE STRUCTURAL INTEGRITY OF THE STRUCTURE, WHICH COULD CAUSE DEATH OR SERIOUS INJURY IN THE EVENT OF FIRE, TIP OVER, ROLL OVER, COLLISION, OR ACCIDENT.

Seat belts are part of your protective system and must be worn at all times. The operator must be held to the seat inside the frame in order for the protective system to work.

Personal Protective Equipment (PPE)

Wear Personal Protective Equipment (PPE) such as hard hat, eye protection, heavy gloves, hearing protection, protective clothing, etc.

Do Not Operate tag

Before you start servicing the machine, attach a 'Do Not Operate' warning tag to the machine in an area that will be visible.

Hazardous chemicals

If you are exposed to or come in contact with hazardous chemicals you can be seriously injured. The fluids, lubricants, paints, adhesives, coolant, etc. required for the function of your machine can be hazardous. They may be attractive and harmful to domestic animals as well as humans.

Material Safety Data Sheets (MSDS) provide information about the chemical substances within a product, safe handling and storage procedures, first aid measures, and procedures to take in the event of a spill or accidental release. MSDS are available from your dealer.

Before you service your machine check the MSDS for each lubricant, fluid, etc. used in this machine. This information indicates the associated risks and will help you service the machine safely. Follow the information in the MSDS, and on manufacturer containers, as well as the information in this manual, when you service the machine.

Dispose of all fluids, filters, and containers in an environmentally safe manner according to local laws and regulations. Check with local environmental and recycling centers or your dealer for correct disposal information.

Store fluids and filters in accordance with local laws and regulations. Use only appropriate containers for the storage of chemicals or petrochemical substances.

Keep out of reach of children or other unauthorized persons.

Applied chemicals require additional precautions. Obtain complete information from the manufacturer or distributor of the chemicals before you use them.

Utility safety

When digging or using ground-engaging equipment, be aware of buried cables and other services. Contact your local utilities or authorities, as appropriate, to determine the locations of services.

Make sure that the machine has sufficient clearance to pass in all directions. Pay special attention to overhead power lines and hanging obstacles. High voltage lines may require significant clearance for safety. Contact local authorities or utilities to obtain safe clearance distances from high voltage power lines.

Retract raised or extended components, if necessary. Remove or lower radio antennas or other accessories. Should a contact between the machine and an electric power source occur, the following precautions must be taken:

- Stop the machine movement immediately.
- Apply the parking brake, stop the engine, and remove the key.
- Check if you can safely leave the cab or your actual position without contact with electrical wires. If not, stay in your position and call for help. If you can leave your position without touching lines, jump clear of the machine to make sure that you do not make contact with the ground and the machine at the same time.
- Do not permit anyone to touch the machine until power has been shut off to the power lines.

Electrical storm safety

Do not operate machine during an electrical storm.

If you are on the ground during an electrical storm, stay away from machinery and equipment. Seek shelter in a permanent, protected structure.

If an electrical storm should strike during operation, remain in the cab. Do not leave the cab or operator's platform. Do not make contact with the ground or objects outside the machine.

Mounting and dismounting

Mount and dismount the machine only at designated locations that have handholds, steps, and/or or ladders.

Do not jump off of the machine.

Make sure that steps, ladders, and platforms remain clean and clear of debris and foreign substances. Injury may result from slippery surfaces.

Face the machine when you mount and dismount the machine.

Maintain a three-point contact with steps, ladders, and handholds.

Never mount or dismount from a moving machine.

Do not use the steering wheel or other controls or accessories as handholds when you enter or exit the cab or operator's platform.

Working at heights

When the normal use and maintenance of the machine requires you to work at heights:

- Correctly use installed steps, ladders, and railings.
- Never use ladders, steps, or railings while the machine is moving.
- Do not stand on surfaces that are not designated as steps or platforms.

Lifting and overhead loads

Never use loader buckets, forks, etc. or other lifting, handling, or digging equipment to lift persons.

Do not use raised equipment as a work platform.

Know the full area of movement of the machine and equipment and do not enter or permit anyone to enter the area of movement while the machine is in operation.

Never enter or permit anyone to enter the area underneath raised equipment. Equipment and/or loads can fall unexpectedly and crush persons underneath it.

Do not leave equipment in raised position while parked or during service, unless securely supported. Hydraulic cylinders must be mechanically locked or supported if they are left in a raised position for service or access.

Loader buckets, forks, etc. or other lifting, handling, or digging equipment and its load will change the center of gravity of the machine. This can cause the machine to tip on slopes or uneven ground.

Load items can fall off the loader bucket or lifting equipment and crush the operator. Care must be taken when lifting a load. Use proper lifting equipment.

Do not lift load higher than necessary. Lower loads to transport. Remember to leave appropriate clearance to the ground and other obstacles.

Equipment and associated loads can block visibility and cause an accident. Do not operate with insufficient visibility.

Do not operate tag

⚠ WARNING

Moving parts!

Disengage the Power Take-Off (PTO), turn off the engine, and remove the key. Wait for all movement to stop before leaving the operator's position. Never adjust, lubricate, clean, or unplug machine with the engine running.

Failure to comply could result in death or serious injury.

W0112A

Before you service the machine, put a DO NOT OPERATE tag on the instrument panel.

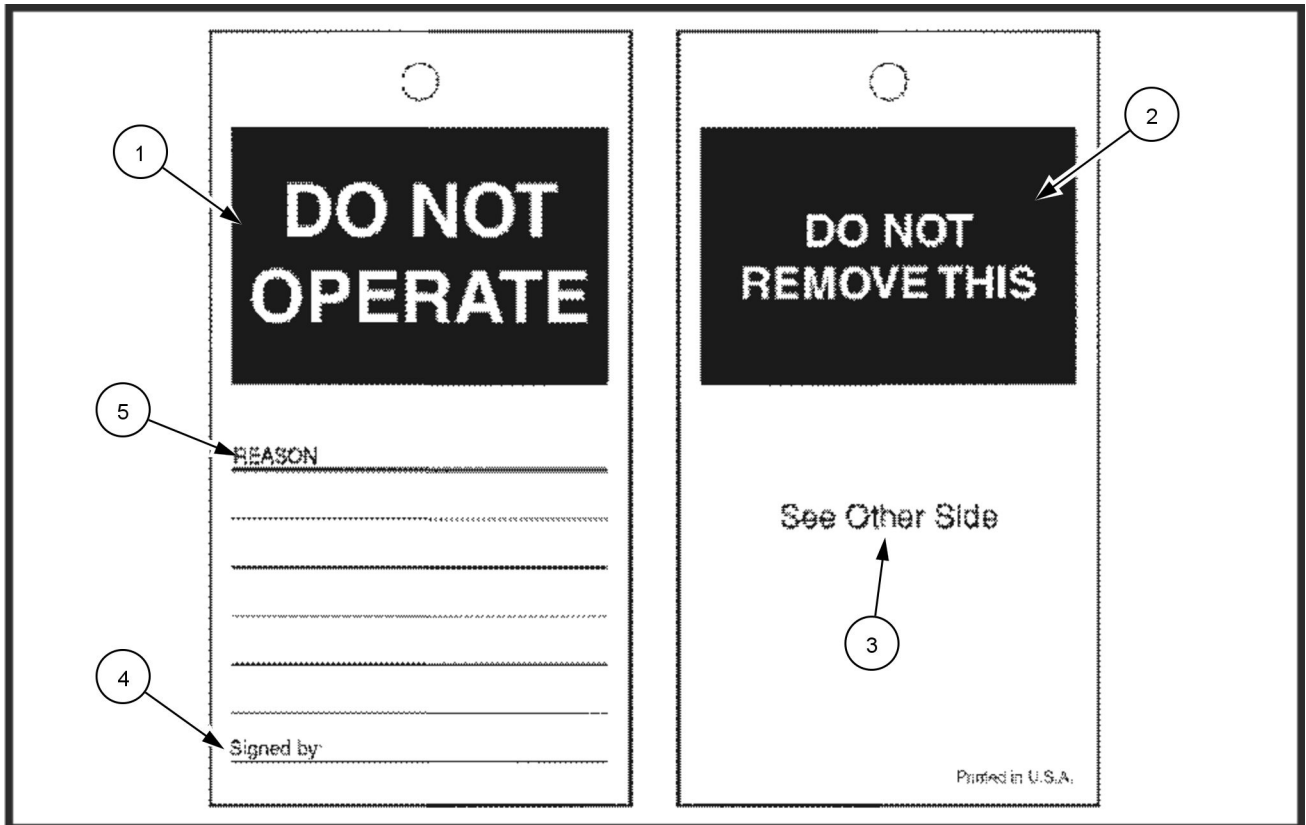

321_4614 1
DO NOT OPERATE TAG

- A. (1) Do not operate.
- B. (2) Do not remove this.
- C. (3) See other side.
- D. (4) Signed by.
- E. (5) Reason

The DO NOT OPERATE tag can be obtained from your NEW HOLLAND dealer.

Roll Over Protective Structure (ROPS) frame - Personal safety

⚠ WARNING

Misuse hazard!

Your machine is equipped with an operator protective structure. DO NOT weld, drill holes, attempt to straighten, or repair the protective structure. Modification in any way can reduce the structural integrity of the structure.

Failure to comply could result in death or serious injury.

W0001B

Your machine is equipped with an operator protective structure, such as a Rollover Protective Structure (ROPS), Falling Object Protective Structure (FOPS), or cab with ROPS. The protective structure is a special safety component of your machine.

A ROPS may be a cab frame or a two-posted or four-posted structure used for the protection of the operator to minimize the possibility of serious injury. The mounting structure and fasteners forming the mounting connection with the machine are part of the ROPS. The seat belt is an integral part of the ROPS.

DO NOT attach any device to the protective structure for pulling purposes. DO NOT drill holes in the protective structure.

The protective structure and interconnecting components are a certified system. Any damage, fire, corrosion, or modification will weaken the structure and reduce your protection. If this occurs, the PROTECTIVE STRUCTURE MUST BE REPLACED so that it will provide the same protection as a new protective structure. Contact your dealer for protective structure inspection and replacement.

After an accident, fire, and tip- or roll-over, the following MUST be performed by a qualified technician before returning the machine to field or job site operation:

- The protective structure MUST BE REPLACED.
- The mounting or suspension for the protective structure, operator seat and suspension, seat belts and mounting components, and wiring within the operator's protective system MUST be carefully inspected for damage.
- All damaged parts MUST BE REPLACED.

DO NOT WELD, DRILL HOLES, ATTEMPT TO STRAIGHTEN, OR REPAIR THE PROTECTIVE STRUCTURE. MODIFICATION IN ANY WAY CAN REDUCE THE STRUCTURAL INTEGRITY OF THE STRUCTURE, WHICH COULD CAUSE DEATH OR SERIOUS INJURY IN THE EVENT OF A FIRE, TIP, ROLLOVER, COLLISION, OR ACCIDENT.

Ecology and the environment

Soil, air, and water quality is important for all industries and life in general. When legislation does not yet rule the treatment of some of the substances that advanced technology requires, sound judgment should govern the use and disposal of products of a chemical and petrochemical nature.

Familiarize yourself with the relative legislation applicable to your country, and make sure that you understand this legislation. Where no legislation exists, obtain information from suppliers of oils, filters, batteries, fuels, anti-freeze, cleaning agents, etc., with regard to the effect of these substances on man and nature and how to safely store, use, and dispose of these substances. Your NEW HOLLAND dealer can also provide assistance.

Helpful hints

- Avoid the use of cans or other inappropriate pressurized fuel delivery systems to fill tanks. Such delivery systems may cause considerable spillage.
- In general, avoid skin contact with all fuels, oils, acids, solvents, etc. Most of these products contain substances that may be harmful to your health.
- Modern oils contain additives. Do not burn contaminated fuels and or waste oils in ordinary heating systems.
- Avoid spillage when you drain fluids such as used engine coolant mixtures, engine oil, hydraulic fluid, brake fluid, etc. Do not mix drained brake fluids or fuels with lubricants. Store all drained fluids safely until you can dispose of the fluids in a proper way that complies with all local legislation and available resources.
- Do not allow coolant mixtures to get into the soil. Collect and dispose of coolant mixtures properly.
- Do not open the air-conditioning system yourself. It contains gases that should not be released into the atmosphere. Your NEW HOLLAND dealer or air-conditioning specialist has a special extractor for this purpose and can recharge the system properly.
- Repair any leaks or defects in the engine cooling system or hydraulic system immediately.
- Do not increase the pressure in a pressurized circuit as this may lead to a component failure.

Battery recycling

Batteries and electric accumulators contain several substances that can have a harmful effect on the environment if the batteries are not properly recycled after use. Improper disposal of batteries can contaminate the soil, groundwater, and waterways. NEW HOLLAND strongly recommends that you return all used batteries to a NEW HOLLAND dealer, who will dispose of the used batteries or recycle the used batteries properly. In some countries, this is a legal requirement.



NHIL14GEN0038AA 1

Mandatory battery recycling

NOTE: The following requirements are mandatory in Brazil.

Batteries are made of lead plates and a sulfuric acid solution. Because batteries contain heavy metals such as lead, CONAMA Resolution 401/2008 as amended by CONAMA Resolution 424/2010 requires you to return all used batteries to the battery dealer when you replace any batteries. Do not dispose of batteries in your household garbage.

Points of sale are obliged to:

- Accept the return of your used batteries
- Store the returned batteries in a suitable location
- Send the returned batteries to the battery manufacturer for recycling

Safety signs

The following safety signs are on your machine as a guide for your safety and for the safety of those working with you. Walk around the machine and note the content and the location of all safety signs before you operate your machine.

Keep all safety signs clean and legible. Clean safety signs with a soft cloth, water, and gentle detergent.

NOTICE: Do not use solvent, gasoline, or other harsh chemicals. Solvents, gasoline, and other harsh chemicals may damage or remove safety signs.

Replace all safety signs that are damaged, missing, painted over, or illegible. If a safety sign is on a part you or your dealer replaces, make sure that you or your dealer install the safety sign on the new part. See your dealer for replacement safety signs.

Replace all safety signs that are damaged, missing, painted over, or illegible. If a safety sign is on a part you or your dealer replaces, make sure that you or your dealer install the safety sign on the new part. See your dealer for replacement safety signs.

Safety signs that display the “Read operator’s manual” symbol direct you to the operator’s manual for further information regarding maintenance, adjustments, or procedures for particular areas of the machine. When a safety sign displays this symbol, consult the appropriate page of the operator’s manual.

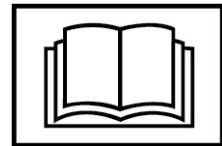

Safety signs that display the “Read service manual” symbol direct you to the service manual. If you doubt your ability to perform service operations, contact your dealer.

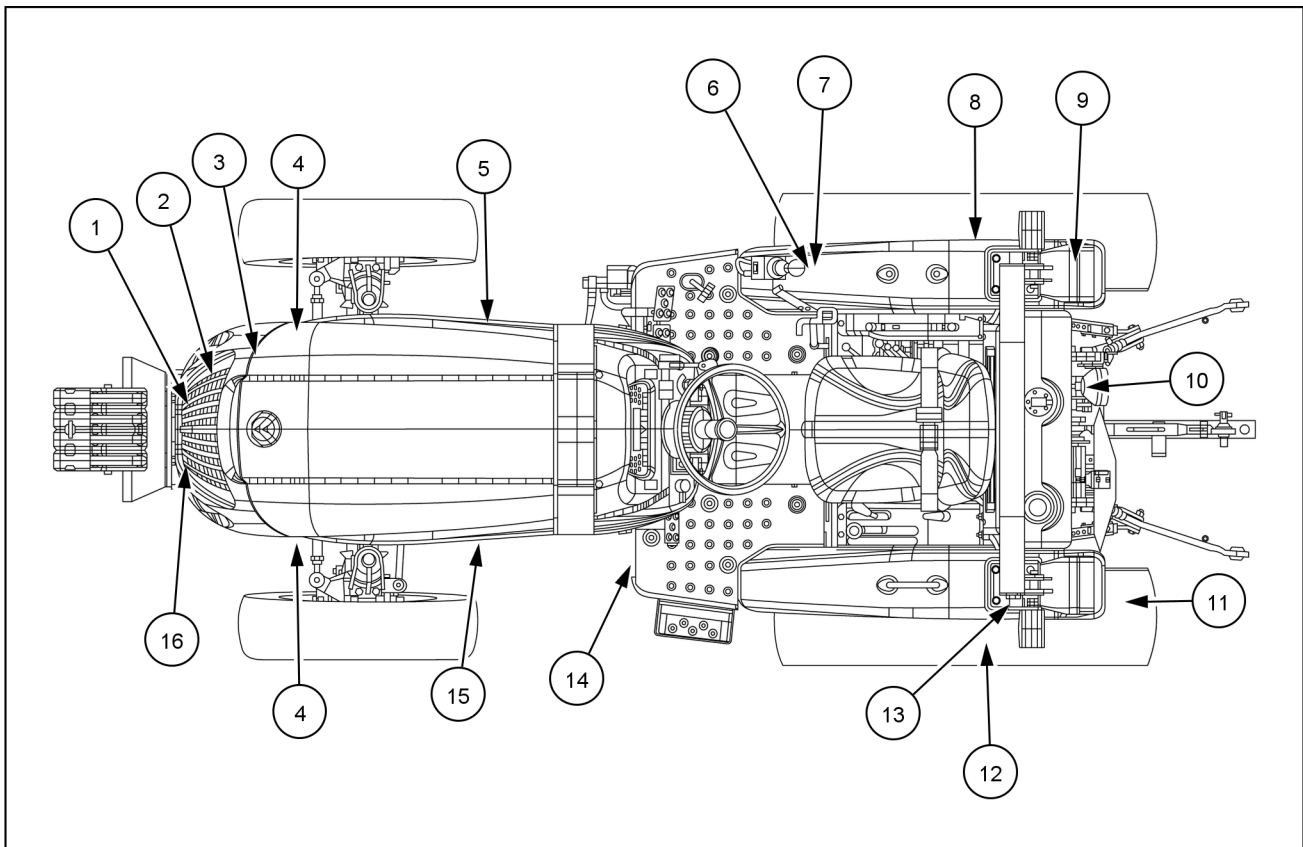

NHIL23CT00511FA 1

(1)
WARNING
EXPLOSIVE

Can cause blindness or severe injury, protect eyes.
 Sparks, flames, cigarettes can cause explosion.
 Tools and cable clamps can cause sparks. Do not use without instruction. Keep vents tight and level.
ACID-POISON causes severe burns. Contains sulphuric acid. In the event of contact flush with water and see a doctor. Keep out of reach of children. Failure to comply could result in death or serious injury.

Quantity: 1
 English Part Number: MT40239639

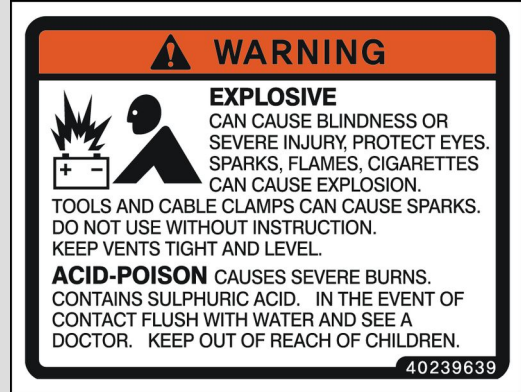

40239639 2

(1) Location: On the right front edge of the battery tray.

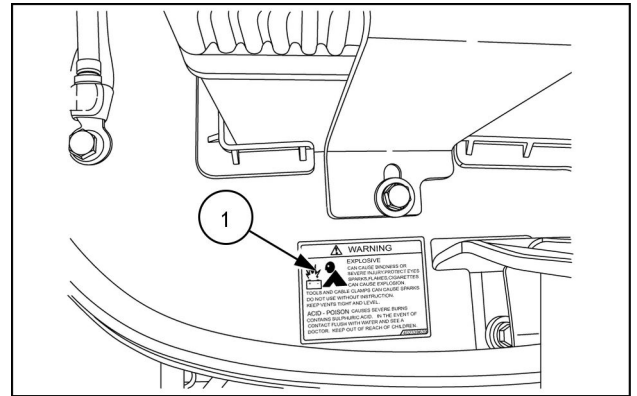

NHIL16CT00699AA 3

(2)

WARNING

• **TO JUMP START (Negative Grounded Battery)**

1. **Shield eyes.**
 2. **Connect end of one cable to positive (+) terminals of each battery.**
 3. **Connect one end of other cable to negative (-) terminal of "Good" battery.**
 4. **Connect other end to engine block of vehicle being started, TO PREVENT DAMAGE to other electrical components on vehicle being started, make certain that engine is at idle speed before disconnecting jumper cables.**
- Failure to comply could result in death or serious injury.**

Quantity: 1

English Part Number: MT40254070

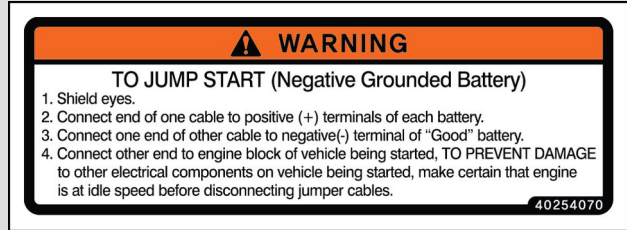

40254070 4

(2) Location: On the air cleaner housing bracket.

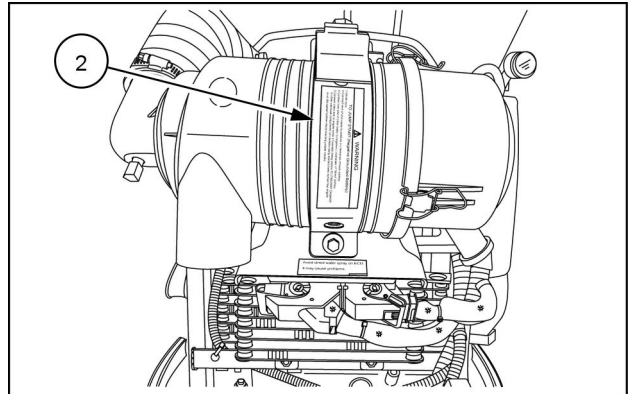

NHIL16CT00697AA 5

(3)
WARNING
 Keep hands and clothing away from the rotating fan and belts.
 Contact with moving parts may cause loss of fingers or a hand.
 Failure to comply could result in death or serious injury.

•

Quantity: 2
 English Part Number: MT40239638



40239638 6

(3) Location: On the left-hand and right-hand sides of the fan shroud.



NHIL13CT00989AA 7

(4)
WARNING
 To prevent serious injury or death.
 Beware hot part.
 Keep clear of muffler to avoid injury.
 Failure to comply could result in minor or moderate injury.

•

Quantity: 1
 English Part Number: MT40239636



40239636 8

(4) Location: Under the hood, on top of the Diesel Particulate Filter (DPF) bracket.

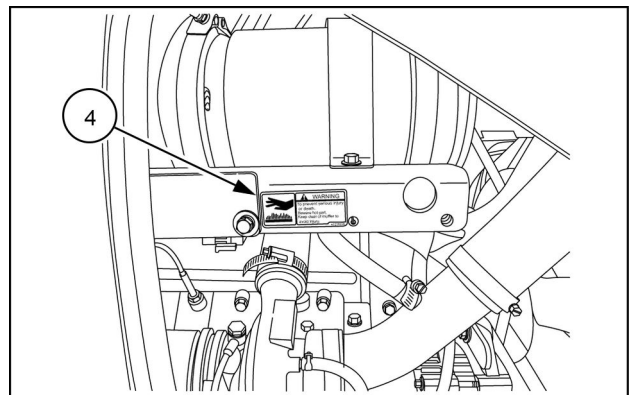

NHIL16CT00704AA 9

(5)

WARNING

To prevent serious injury or death.

- During the DPF regeneration process, The exhaust stack and fixed hood area becomes extremely hot.
 - Park the tractor away from highly flammable material and person.
- Failure to comply could result in death or serious injury.

Quantity: 1

English Part Number: MT40342880/00

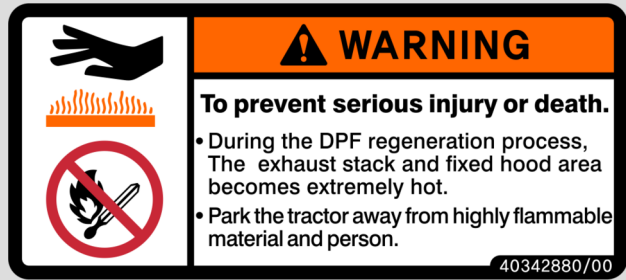

40342880 10

(5) Location: On the right-hand side of the engine hood, outside.



NHIL16CT00696AA 11

**(6)
JOYSTICK LEVER USAGE
WARNING**

**To avoid personal injury:
Wrong operation causes serious injury easily.
Push the lever (1) in to lock the joystick in neutral.
Failure to comply could result in death or serious
injury.**

**Quantity: 1
English Part Number: MT40226388**

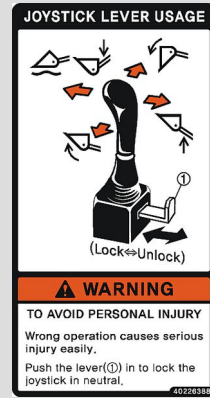

40226388 12

(6) Location: On the right-hand fender.

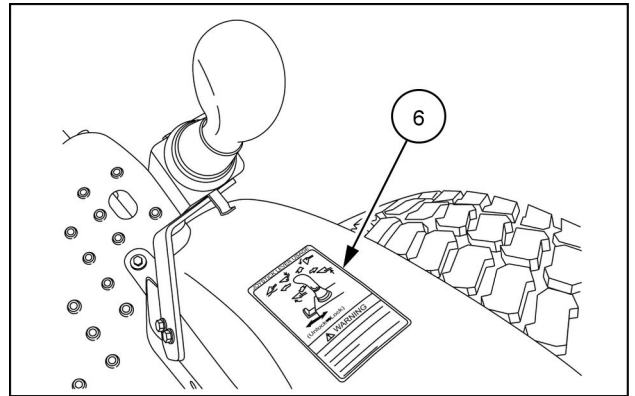

NHIL15CT00372AA 13

(7)
CAUTION

Periodically, the DPF will require regeneration. This is an automatic function unless inhibited by the operator.

1. **Automatic:** The DPF regen lamp will illuminate indicating regeneration is needed. If the operator does not inhibit the regeneration with the switch, the DPF temperature will also come on and the engine control unit will automatically begin regeneration.

NOTE: Under light or no load conditions, increase the engine RPMs above 2,200rpm when possible

2. **Inhibit:** In case the tractor is operated in extremely flammable material and the operator wishes to delay the regeneration process, press downward on the DPF switch for 1-2 seconds. The inhibit lamp will illuminate and regeneration will be postponed.

(Beware: Inhibit is only intended for a few moments and the DPF must regen. If the DPF lamp begins to blink, quickly move to a safe area, move the shuttle to neutral, apply the parking brake, bring engine to the lowest RPMs and press up on the DPF switch for 3 seconds. The inhibit lamp will go off and the engine control unit will begin regeneration.)

3. **Forced Regen:** It is possible to force regeneration before the soot is high enough for automatic regeneration. To force regeneration, shuttle to neutral, apply the parking brake, bring engine to the lowest RPMs and press up on the DPF switch for 3 seconds.

Quantity: 1

English Part Number: MT40363308/00

4036330800 14

(7) Location: On the right-hand side control pod.

NHILCT1700111AA 15

(8)
WARNING
HIGH PRESSURE FLUID HAZARD
To prevent serious injury or death

- Relieve pressure on system before repairing, adjusting or disconnecting.
- Wear proper hand and eye protection when searching for leaks, use wood or cardboard instead of hands.
- If hydraulic fluid or fuel sinks into skin, seek medical attention immediately.

Quantity: 1
English Part Number: MT40195652



40195652 16

(8) Location: On top of the right-hand fender.

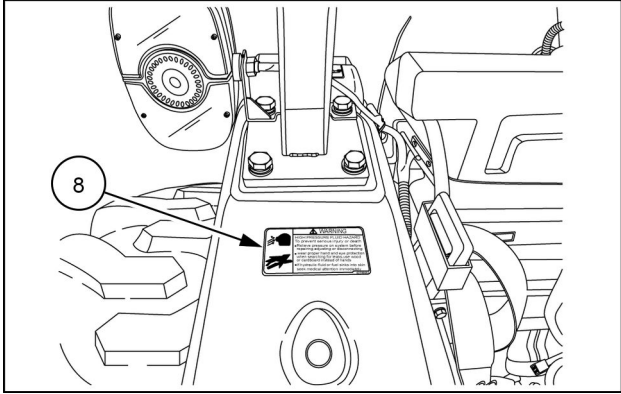

NHIL15CT00325AA 17

(9)
WARNING
Operate control only from tractor seat.
Failure to comply could result in death or serious injury.

-

Quantity: 2
English Part Number: MT40229994



40229994 18

(9) Location: On the rear of the left-hand and right-hand fenders.

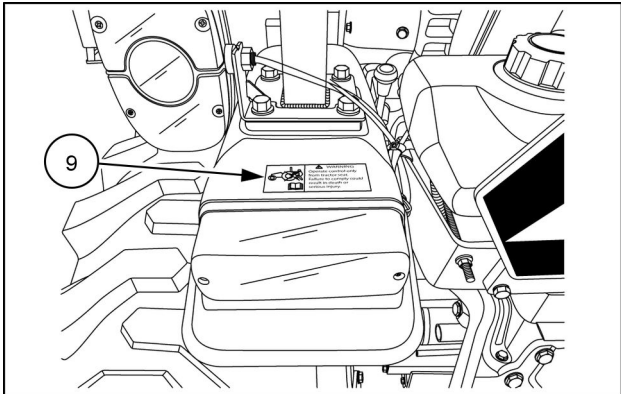

NHIL15CT00326AA 19

(10)
Reflective red tape

Quantity: 2
English Part Number: MT40310801



86547781_RED 20

(10) Location: On both rear sides of the Roll Over Protective Structure (ROPS).

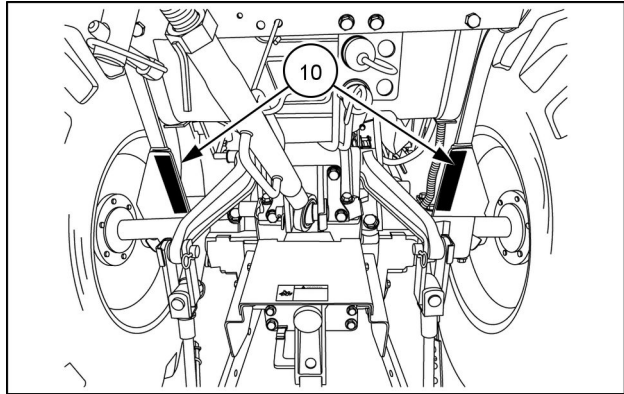

NHIL15CT00331AA 21

(11)
WARNING

- Rotating driveline contact may cause serious injury or death.
- Keep all driveline, tractor and equipment shields in place during operation.

Quantity: 1
English Part Number: MT40195650



40195650 22

(11) Location: On top of the rear PTO guard.

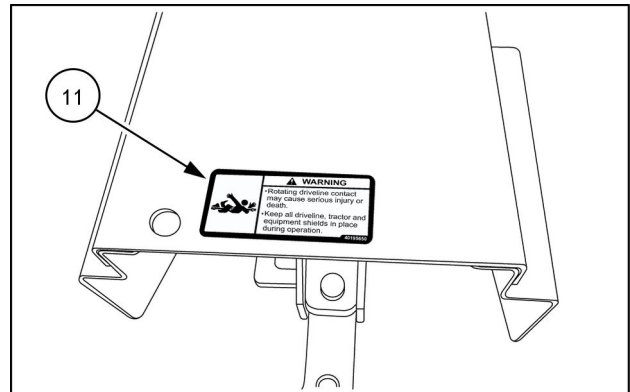

NHIL13CT01010AA 23

(12)
WARNING

To prevent serious injury or death:

- Never operate a tractor without a certified ROPS.
 - Always fasten seat belt when operating tractor with ROPS in upright position.
 - Do not operate the tractor on steep slopes or drop-off.
 - Avoid sharp turns at high speeds.
 - Use of ROPS and seat belt reduce the chance of injury or death if rollover or upset occur.
 - Do not attach ropes or chains to ROPS for pulling purpose.
- Failure to comply could result in death or serious injury.

Quantity: 1
 English Part Number: MT40234561

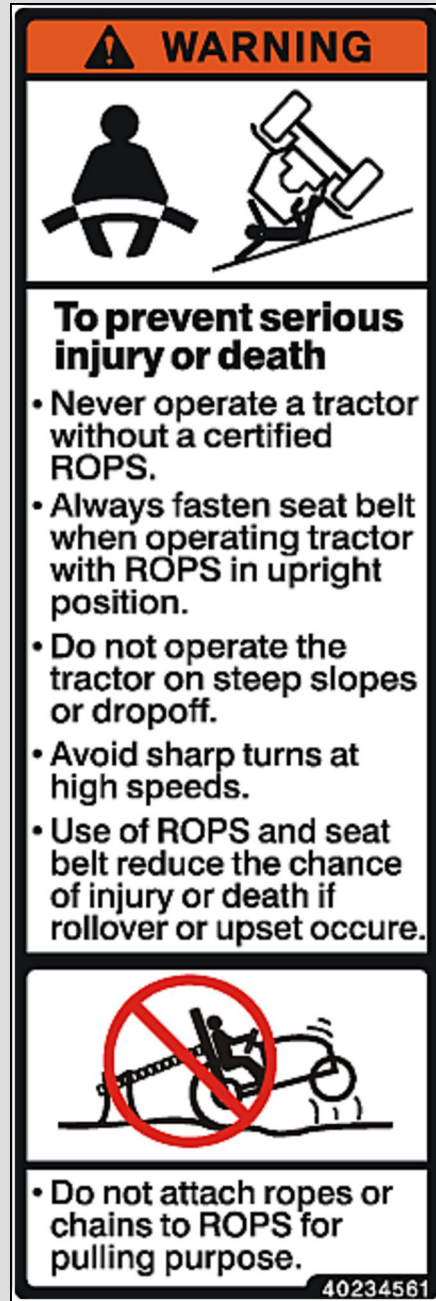

40234561 24

(12) Location: On the left-hand side of the ROPS frame.

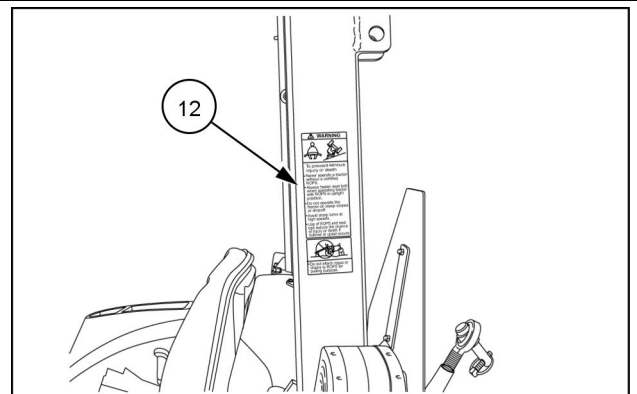

83115221 25

(13)

Multiple Safety Cautions and Warnings

CAUTION

- PTO selector & lever must be in the "OFF" position to start engine.
- Do not operate on hard surfaces with 4WD engaged.

WARNING

To prevent serious injury or death:

- After first hour of operation and daily thereafter, check front and rear wheel lug nuts and bolts for proper torque.
- PTO-keep hands, feet and clothing away from PTO & other moving parts.
- Disengage PTO and shut off engine before servicing tractor or implements or attaching or detaching implements.
- Keep all safety shields in place for your protection.
- Pull only from approved drawbar or lower links of 3-point hitch at horizontal position or below.
- Lock tractor brake pedals together for travel on roads or highways.
- Always apply parking brake and shift transmission to neutral before dismounting.
- Always use a seat belt when you operate the tractor.
- Allow no riders on tractor or implements.
- Always use a seat belt when you operate the tractor.

CAUTION

- PTO selector & lever must be in "OFF" position to start engine.
- Do not operate on hard surfaces with 4WD engaged.

WARNING

To prevent serious injury or death

- After first hour of operation and daily thereafter, check front and rear wheel lug nuts and bolts for proper torque.
- PTO – keep hands, feet and clothing away from PTO & other moving parts.
- Disengage PTO and shut off engine before servicing tractor or implements or attaching or detaching implements.
- Keep all safety shields in place for your protection.
- Pull only from approved drawbar or lower links of 3-point hitch at horizontal position or below.
- Lock tractor brake pedals together for travel on roads or highways.
- Always apply parking brake and shift transmission to neutral before dismounting.
- Allow no riders on tractor or implements.

To prevent serious injury or death



- Always use a seat belt when you operate the tractor.
- Do not use a seat belt when operating with folding ROPS in lowered position.



- Engine exhaust fumes can cause death or sickness.
- Always try to work in a well ventilated area.

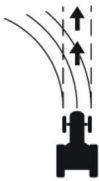

- Disengage the differential lock when turning the tractor.
- Always disengage the differential lock when driving on roads.
- Depress one or both brake pedals to disengage the differential lock.

40195656

- Do not use a seat belt when operating with folding ROPS in lowered position.
 - Engine exhaust fumes can cause death or sickness. Always try to work in a well ventilated area.
 - Disengage the differential lock when turning the tractor. Always disengage the differential lock when driving on roads.
 - Depress one or both brake pedals to disengage the differential lock.
- Failure to comply could result in death or serious injury.

Quantity: 1

English Part Number: MT40195656

(13) Location: On the top of the left-hand fender.

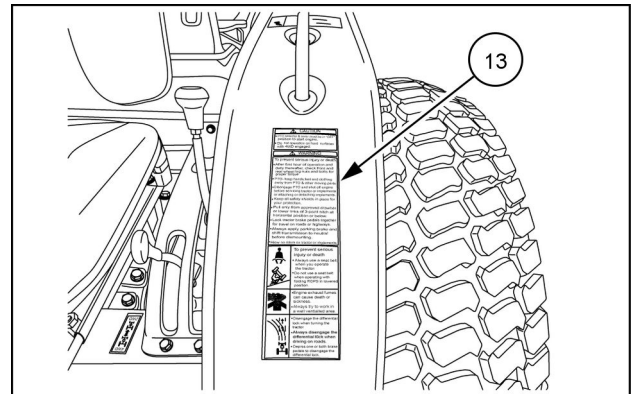

NHIL15CT00371AA 27

(14)

WARNING
TO PREVENT DEATH OR SERIOUS INJURY
Whenever clearance permits

- Keep ROPS fully upright and locked
- Do not operate vehicle without ROPS locking pins in position
- When ROPS must be lowered:
 - Drive with extreme care.
 - Seat belt use is not recommended.
- Do not attempt to fold ROPS when a canopy is fitted.
- ROPS is heavy. Always work with an assistant when lowering and raising the ROPS.

No roll over protection is provided when ROPS is in lowered position
Failure to comply could result in death or serious injury

Quantity: 1
English Part Number: MT40234715

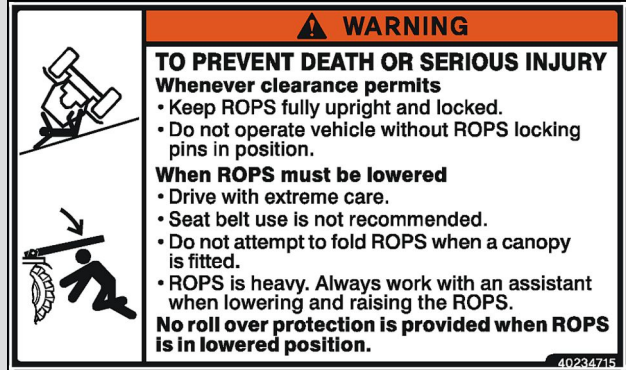

40234715 28

(14) Location: On top of the left-hand fender.

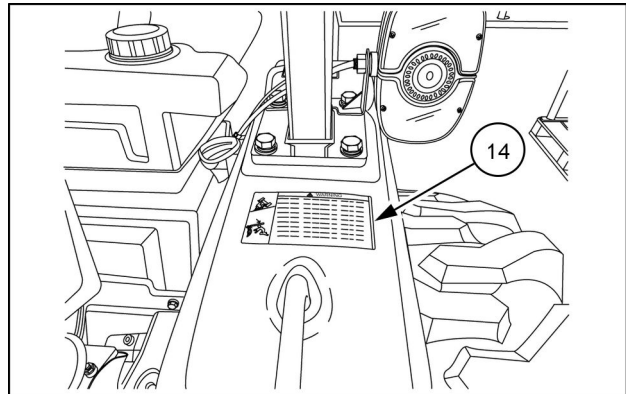

NHIL15CT00327AA 29

(15)
WARNING
RUN OVER HAZARD
 To prevent serious injury or death:

- Start only from seat with transmission and PTO in neutral
- Do not short across starter terminals to start engine.

Failure to comply could result in death or serious injury.
 Quantity: 1
 English Part Number: MT40195651



40195651 30

(15) Location: On the left-hand side of the engine frame.

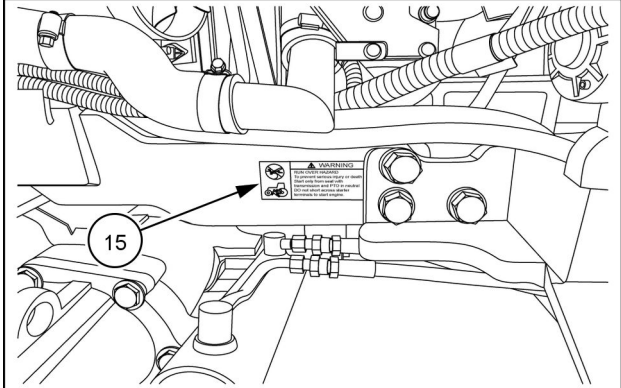

NHIL15CT00332AA 31

(16)
CAUTION

USE OF ANY OIL OTHER THAN MAY CLOG THE DPF EARLIER THAN EXPECTED

USE ONLY API CJ-4 ENGINE OIL

Quantity: 1
 English Part Number: MT40342881/00

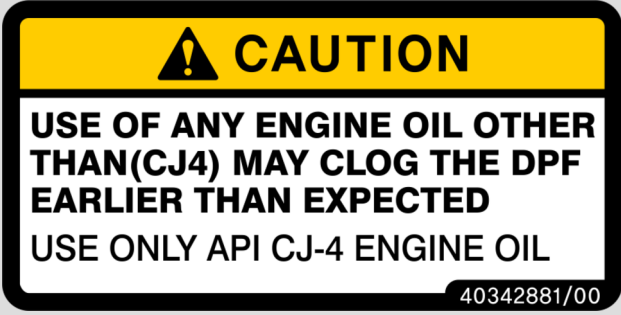

40342881 32

(16) Location: Left-hand side hood.

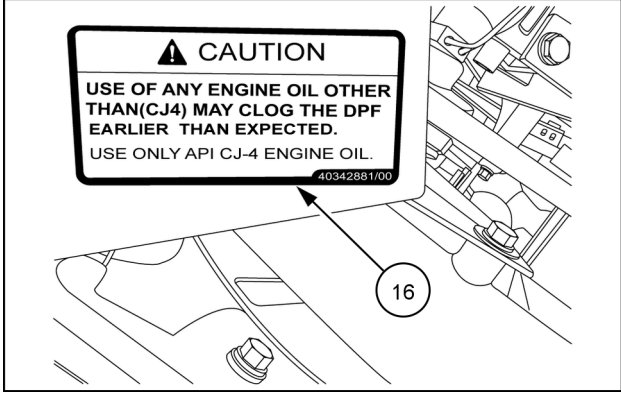

NHIL16CT00695AA 33

(17)

WARNING

To prevent serious injury or death.
High pressure steam and hot water.
Remove filler cap with extreme care.
Failure to comply could result in death or serious injury.

Quantity: 1

English Part Number: MT40297729



40297729 34

(17) Location: On engine air cleaner top support bracket.

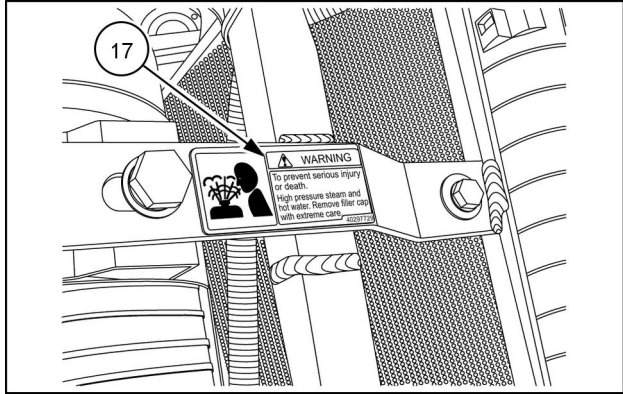

NHIL17CT00210AA 35

Instructional signs

The following instructional decals have been placed on your tractor in the area indicated. They are intended to instruct you and those working with you. Please take this manual and walk around your tractor to note the content and location of these decals. Review the decals and operating instructions detailed in this manual with the tractor operators. Keep the decals clean and legible. If they become damaged or illegible, obtain replacements from your authorized NEW HOLLAND dealer.

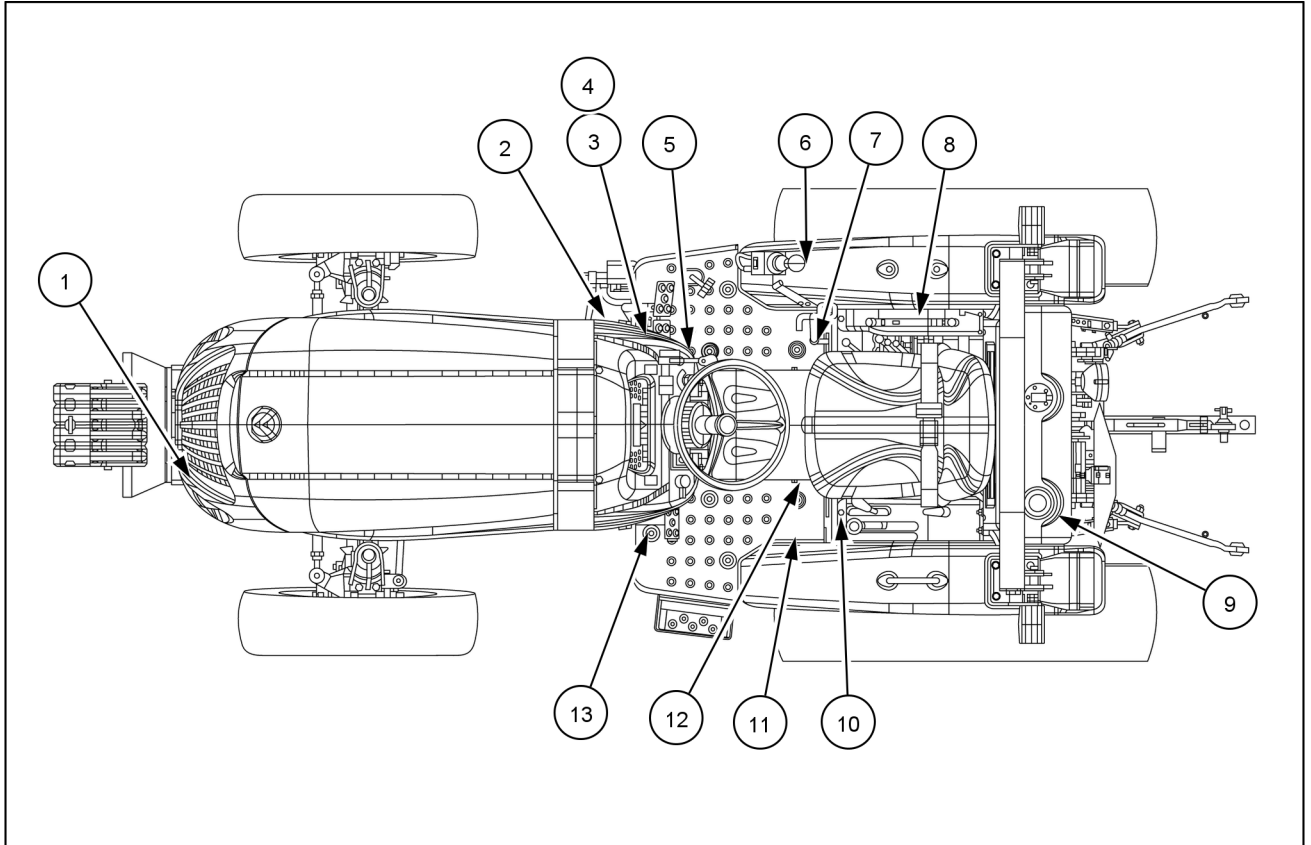

NHIL23CT00511FA 1

(1)

Avoid direct water spray on ECU

- English MT40312336.00

Location: On the left-hand side of the battery tray.

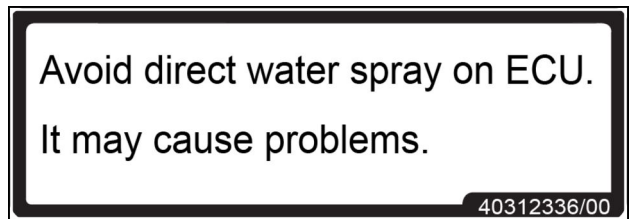

40312336.00 2

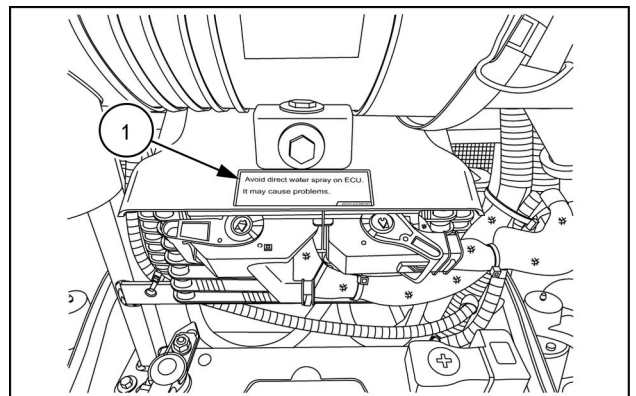

NHIL16CT00698AA 3

(2)
Key Switch

- English MT40008779

Location: Right-hand side of the rear hood panel.

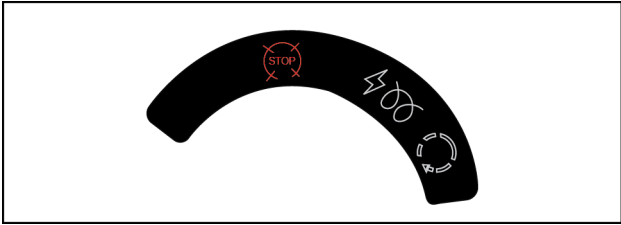

40008779 4

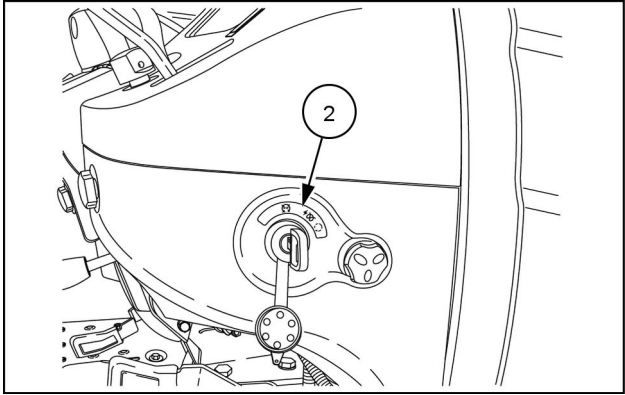

NHIL15CT00472AA 5

(3)
Hand Throttle Lever

- English MT40233965

Location: On the right-hand side of the dash panel.

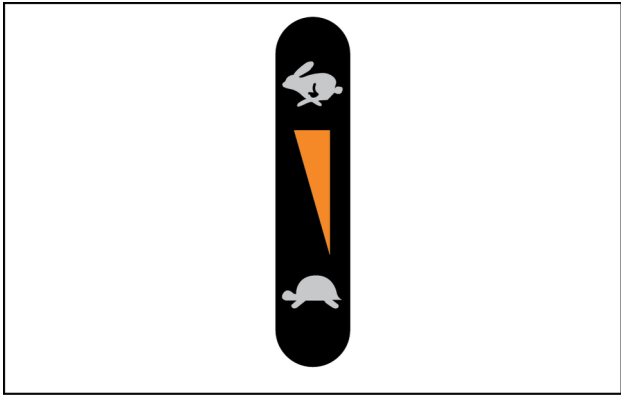

40233965 6

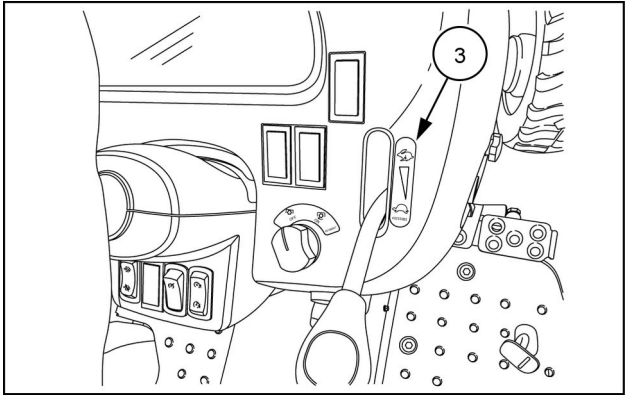

NHIL17CT00211AA 7

(4)

PTO Switch

- English MT40189937

Location: On the right-hand side of the dash panel.

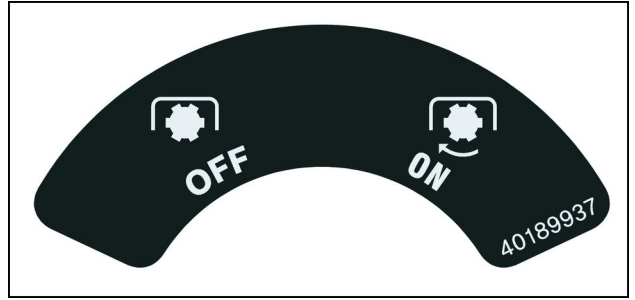

40189937 8

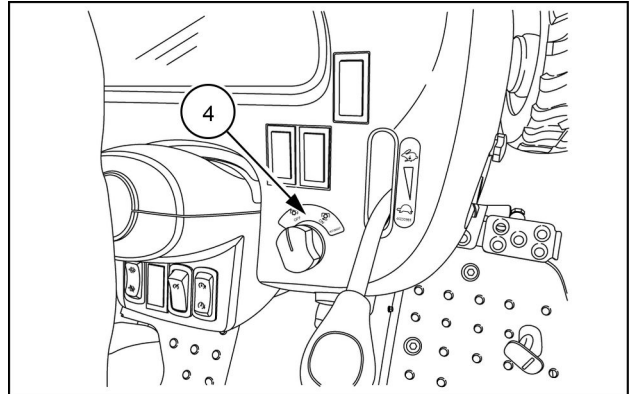

NHIL17CT00211AA 9

(5)

Hydrostatic (HST) cruise control

- English MT40008891

Location: Center of the rear hood panel.

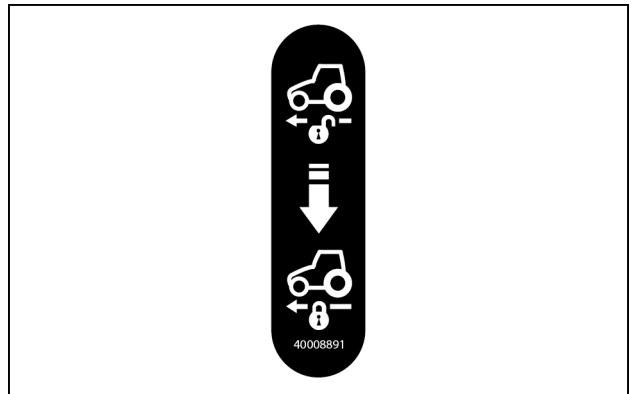

40008891C 10

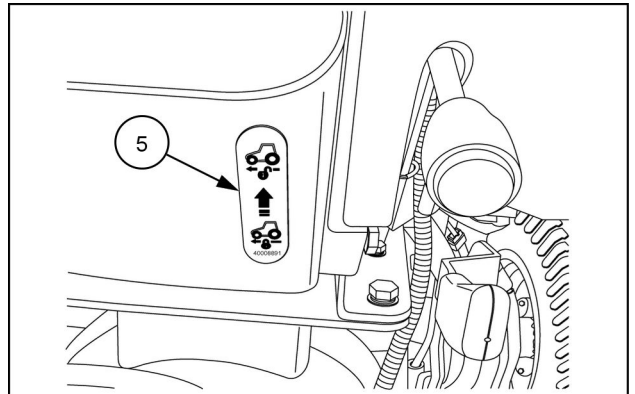

NHIL15CT00354AA 11

(6)
Mid Mount Valve Operation

- English MT40226388

Location: On the right-hand fender.



40194109 12

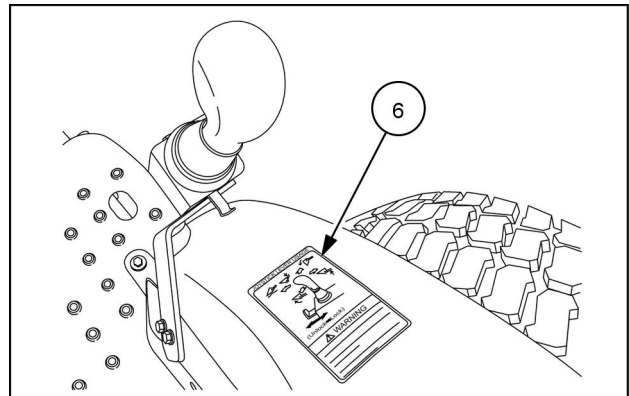

NHIL15CT00372AA 13

(7)
Rear remote valve(s) operation (Optional)

- English MT40256190

Location: On the right-hand side of the platform shield below the drivers seat.

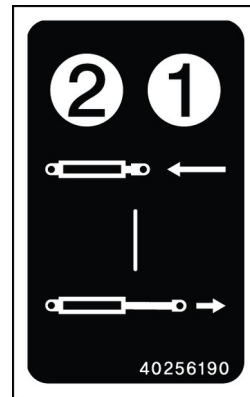

40256190 14

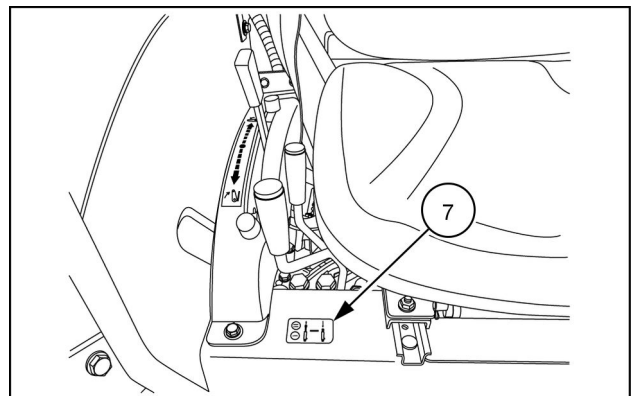

NHIL15CT00374AA 15

(8)

Position Control Lever

- English MT40254069

Location: On the right-hand side control pod, next to the drivers seat and right-hand fender.

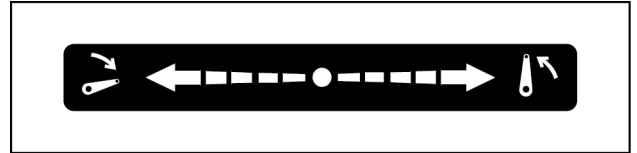

40254069 16

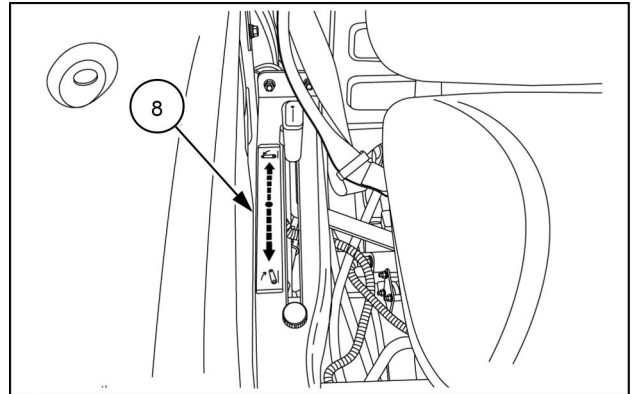

NHIL12CT00681AA 17

(9)

Fuel

Ultra low sulfur diesel fuel only

- English MT40241059

Location: On top of the left-hand side fender.



40241059 18

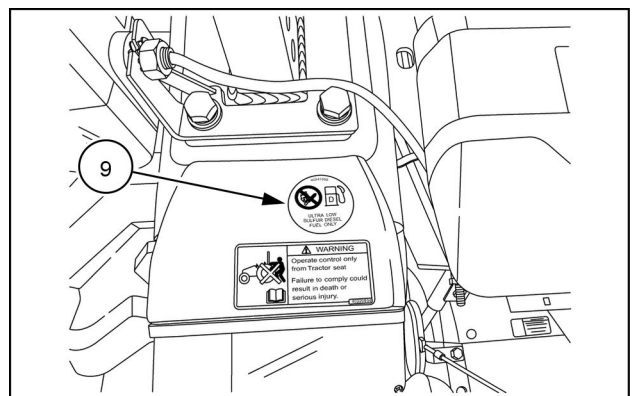

NHIL17CT00212AA 19

(10)

Four wheel drive engagement lever

- English MT40032976

Location: To the left side of the drivers seat.

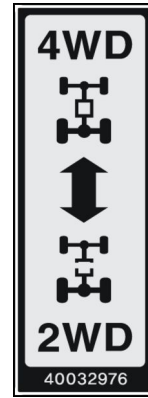

40032976 20

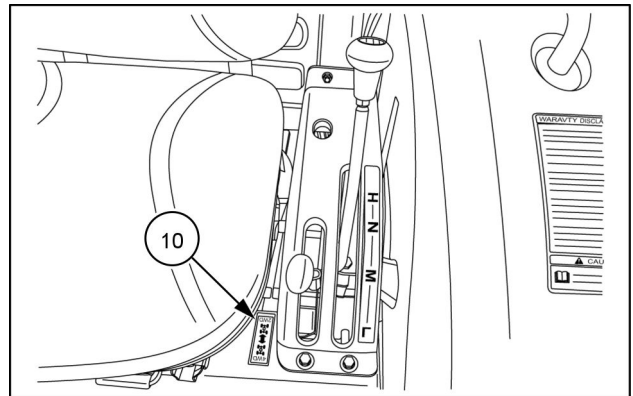

NHIL12CT00680AA 21

(11)

Differential lock

- English MT40008815

Location: Hydrostatic (HST) - Left-hand side of operator's platform

Mechanical - Right-hand side of operator's platform.

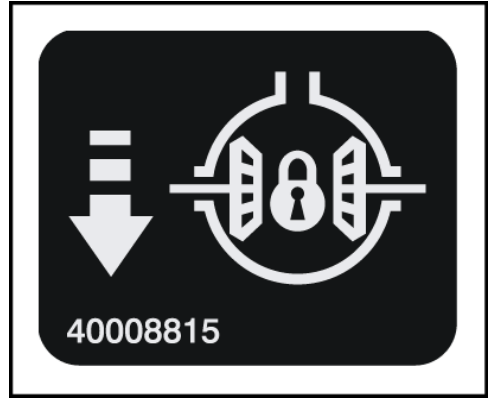

40008815 22

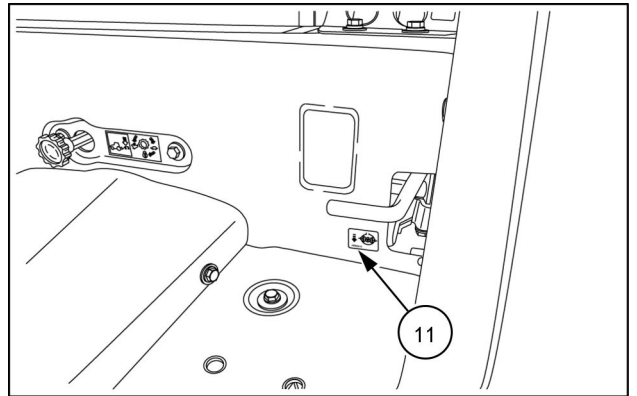

NHIL12CT00687AA 23

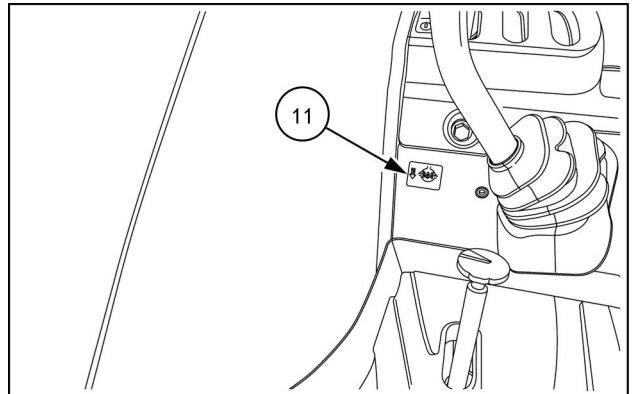

NHIL13CT01240AA 24

(12)

Drop Rate Control Valve

- English MT40008821

Location: Below the drivers seat.

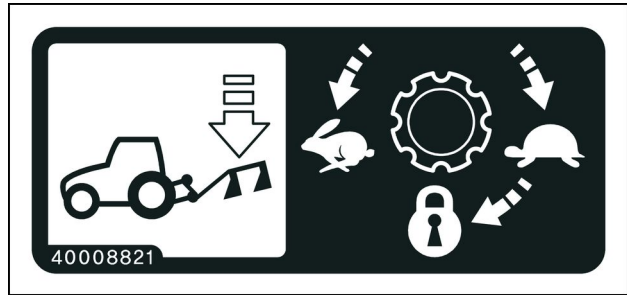

40008821 25

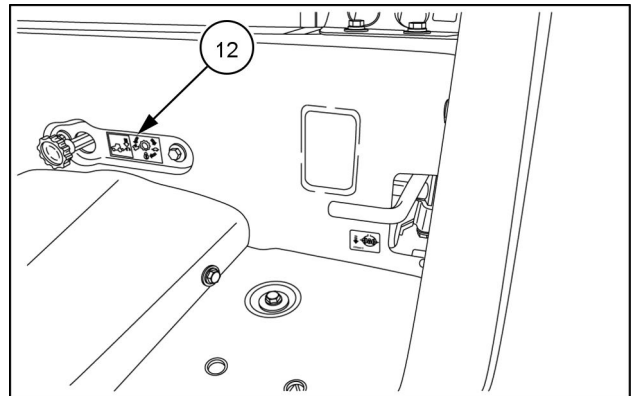

NHIL12CT00687AA 26

(13)

Park brake

- English MT40277509

Location: On the park brake engagement lever.

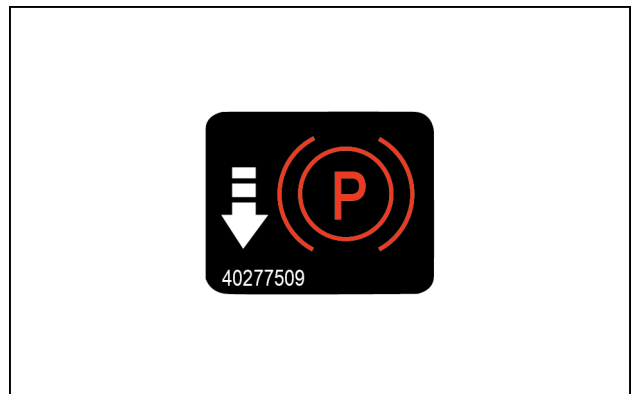

40277509B 27

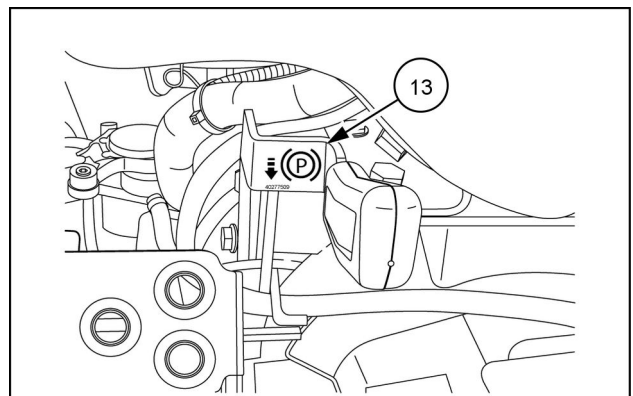

NHIL15CT00353AA 28

Safety features

▲ WARNING

Misuse hazard!

Your machine is equipped with an operator protective structure. DO NOT weld, drill holes, attempt to straighten, or repair the protective structure. Modification in any way can reduce the structural integrity of the structure.

Failure to comply could result in death or serious injury.

W0001B

Your machine is equipped with an operator protective structure, such as a Rollover Protective Structure (ROPS), Falling Object Protective Structure (FOPS), or cab with ROPS. The protective structure is a special safety component of your machine.

A ROPS may be a cab frame or a two-posted or four-posted structure used for the protection of the operator to minimize the possibility of serious injury. The mounting structure and fasteners forming the mounting connection with the machine are part of the ROPS. The seat belt is an integral part of the ROPS.

NOTICE: *DO NOT attach any device to the protective structure for pulling purposes. DO NOT drill holes in the protective structure.*

The protective structure and interconnecting components are a certified system. Any damage, fire, corrosion, or modification will weaken the structure and reduce your protection. If this occurs, the PROTECTIVE STRUCTURE MUST BE REPLACED so that it will provide the same protection as a new protective structure. Contact your dealer for protective structure inspection and replacement.

After an accident, fire, and tip- or roll-over, the following MUST be performed by a qualified technician before returning the machine to field or job site operation:

- The protective structure MUST BE REPLACED.
- The mounting or suspension for the protective structure, operator seat and suspension, seat belts and mounting components, and wiring within the operator's protective system MUST be carefully inspected for damage.
- All damaged parts MUST BE REPLACED.

NOTICE: *DO NOT WELD, DRILL HOLES, ATTEMPT TO STRAIGHTEN, OR REPAIR THE PROTECTIVE STRUCTURE. MODIFICATION IN ANY WAY CAN REDUCE THE STRUCTURAL INTEGRITY OF THE STRUCTURE, WHICH COULD CAUSE DEATH OR SERIOUS INJURY IN THE EVENT OF A FIRE, TIP, ROLLOVER, COLLISION, OR ACCIDENT.*

3 - CONTROLS AND INSTRUMENTS

Access to operator's platform

Access to operator's platform

Roll Over Protective Structure (ROPS) type tractor

Entering and exiting the tractor:

- Whenever possible, use the left-hand side step (1) for entering and exiting the tractor operator's platform.
- When boarding the tractor, use the step (1), steering wheel (2) and grab handle (3) on the left fender.

⚠ WARNING

Fall hazard!

Jumping on or off the machine could cause an injury. Always face the machine, use the handrails and steps, and get on or off slowly. Maintain a three-point contact to avoid falling: both hands on the handrails and one foot on the step, or one hand on the handrail and both feet on the steps.

Failure to comply could result in death or serious injury.

W0141A

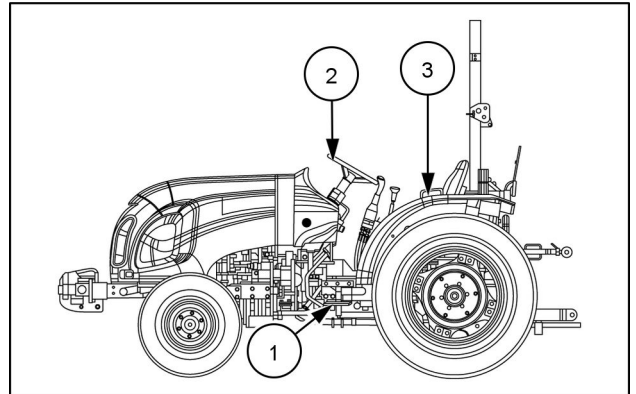

NHIL23CT00447AA 1

Operator's seat

Seat belt

The male end of the seat belt (1) is located on right-hand side of the seat. To extend length of seat belt, pull out on male end until correct length is obtained. To latch seat belt, insert male end into the buckle (2) located on left-hand side of the seat. Make sure belt is securely buckled and belt length is adjusted correctly for size of operator.

Use soap and water to clean the seat belt if necessary. Do not use carbon tetrachloride, naphtha, etc., as these substances will weaken the webbing. Additionally, do not bleach or dye the webbing, as these products will also weaken the webbing.

Replace the seat belt if it becomes damaged or worn.

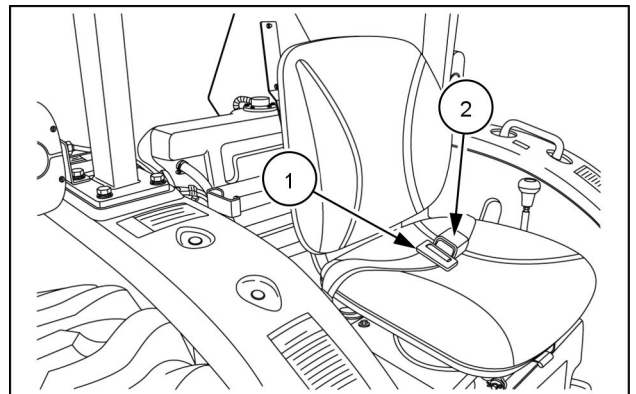

NHIL12CT00690AA 1

Mechanically - adjusted operator seat

Adjusting the tractor seat

Your tractor is equipped with an adjustable suspension seat.

To move the seat forward or backwards, raise the adjustment lever (1), and move the seat rearward or forward in the seat track. After the seat is adjusted, release the adjustment lever.

The seat can be tilted forward for storage position.

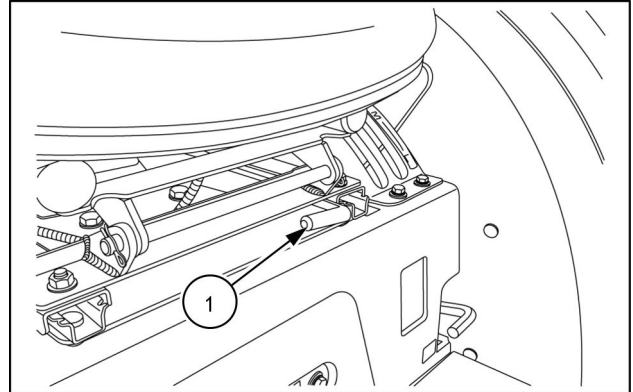

NHIL12CT00682AA 1

NOTE: Care of vinyl, plastic, and rubber parts to MAXIMIZE life

For cleaning of vinyl, plastic, and rubber parts, use "ONLY" a mild car washing soap and water, as described below:

"First remove any loose dirt by rinsing with clean water. Mix a warm, mild liquid CAR WASHING soap solution (1 part soap and 99 parts water). Then using a sponge or soft cloth, apply the soap solution to the part. Allow the solution to soak for a few minutes to loosen the dirt. Finally, rinse the part with clean water to remove the dirt, and any solution residue. If all the dirt does not come off, repeat the procedure."

Roll Over Protective Structure (ROPS)

⚠ WARNING

Misuse hazard!

Your machine is equipped with an operator protective structure. **DO NOT** weld, drill holes, attempt to straighten, or repair the protective structure. Modification in any way can reduce the structural integrity of the structure.

Failure to comply could result in death or serious injury.

W0001B

⚠ WARNING

Roll-over hazard!

A folded Roll-Over Protective Structure (ROPS) does not provide roll-over protection. **Do not** operate the machine with the ROPS folded as a standard operating mode. Raise the ROPS immediately after low clearance use or transport.

Failure to comply could result in death or serious injury.

W0938A

⚠ WARNING

Roll-over hazard!

Always pull from the drawbar. **DO NOT** attach chains or ropes to the Roll Over Protective Structure (ROPS) for pulling purposes, as the machine could tip over. When driving through door openings or under low overhead objects, make sure there is sufficient clearance for the ROPS.

Failure to comply could result in death or serious injury.

W0463A

⚠ WARNING

Crushing hazard!

Always wear the seat belt when operating the machine with the Roll Over Protective Structure (ROPS) in the upright position. If the ROPS is in the folded position, the seat belt should not be used. Raise the ROPS and wear the seat belt as soon as conditions allow.

Failure to comply could result in death or serious injury.

W0462A

A Rollover Protective Structure (ROPS) (1) and seat belts (2) are standard equipment on this tractor at the time of factory assembly. If the ROPS was removed by the original purchaser or has been removed, it is recommended that you equip your tractor with a ROPS and seat belts.

ROPS are effective in reducing injuries in the event of tractor overturn. Overturning a tractor without a ROPS installed can result in serious injury or death. The Rollover Protective Structure and seat belts are available from your NEW HOLLAND Dealer.

Additionally, the safety offered by the ROPS and seat belt is minimized if your seat belt is not buckled. Always use your seat belt when the ROPS is in the "UP" position, it can save your life.

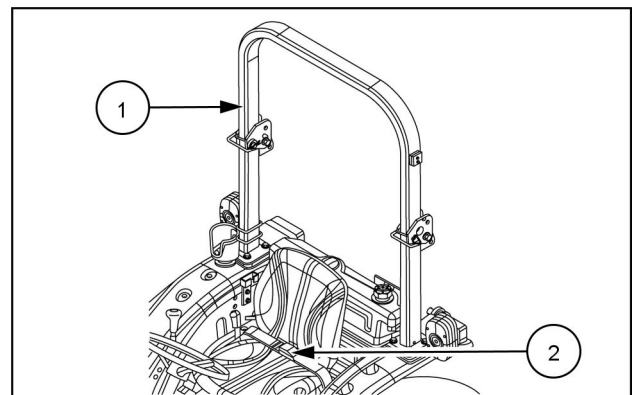

NHIL23CT00433AA 1

Foldable ROPS

- The Roll-Over Protective Structure (ROPS) is integrated and certified structure for driver's safety. This structure will reduce the risk of serious injury or death when being over-turned.
- DO NOT remove, modify or repair the ROPS arbitrarily. The welding, bending, drilling, grinding, or cutting of any part of the ROPS, it can weaken the structure.
- DO NOT remove, modify or repair the ROPS arbitrarily. The welding, bending, drilling, grinding, or cutting of any part of the ROPS, it can weaken the structure.

To fold the upper frame of the ROPS, do the following:

1. Loosen the bolts (2), and (4) and the nuts on both sides.

NOTE: It is not necessary to remove the hardware completely.

2. Remove the pins (3) on both sides and fold the upper frame backward.

NOTICE: Be careful of the possibility that your body might be hurt by sudden folding due to its own weight.

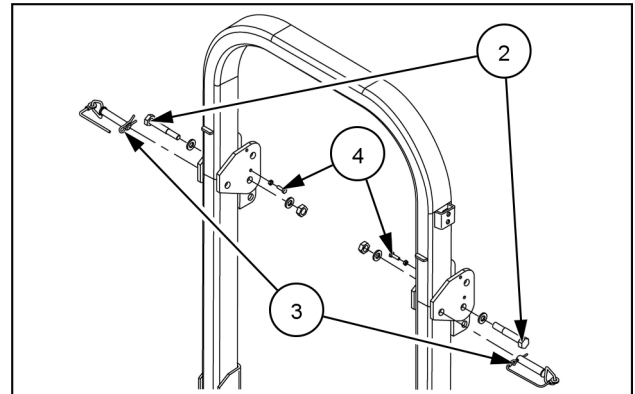

NHIL23CT00434AA 2

3. Align the holes of the frame (1) and (5) in line, and insert the pins (3) into the hole and apply the snap pins.
4. Fasten the bolts (2) and (4) and the nuts on both sides tightly.

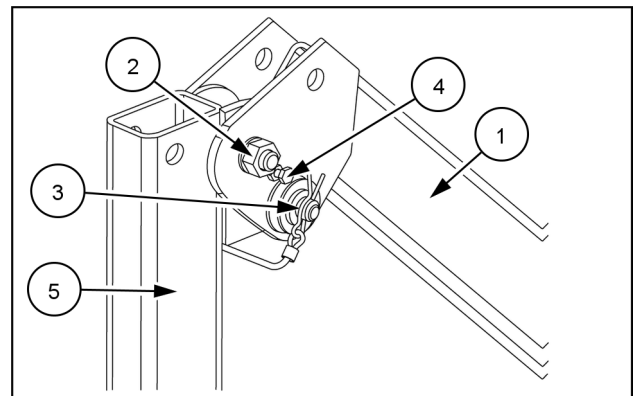

NHIL23CT00435AA 3

Forward controls

Instrument panel

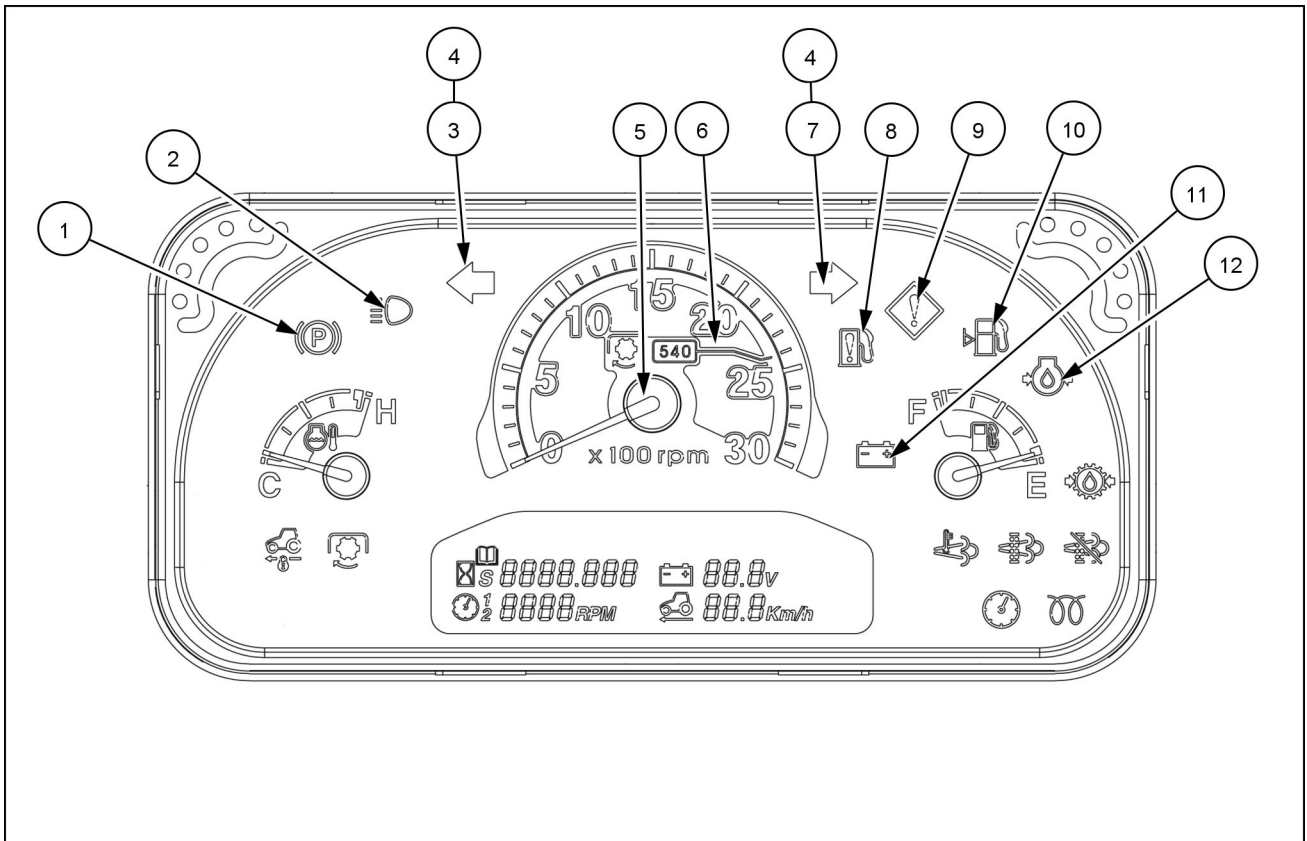

NHIL16CT00387FA 1

1. Park Brake Indicator Light - Illuminates if the park brake is engaged with the key switch rotated from the "OFF" position.
2. High beam indicator - Turning on the high beam of the headlamp, this indicator will be ON simultaneously.
3. Left Flasher Turn Lights - Operate when the multifunction switch lever is moved downwards for left turns the left arrow will flash. The key switch has to be in the "ON" or "START" positions.
4. Flasher Warning Lights - Operate when the operator places the multifunction switch in the hazard or road lights position, regardless of the key switch position. Use the flasher warning lights, road lights when traveling on public roads, day or night.
5. Tachometer - Registers engine Revolutions Per Minute (RPM). The gauge is marked in increments of 100 and will return to zero when the engine is not running.
6. PTO Speed Indicator - Determined by the position of the needle on the tachometer. The tachometer is marked to indicate **540 RPM** of PTO. If the needle registers above the **540 RPM** mark, this indicates a dangerous over speed condition, reduce the engine (RPM) immediately.
7. Right Flasher Turn Lights - Operate when the multifunction switch lever is moved upwards for right turns the right arrow will flash. The key switch has to be in the "ON" or "START" positions.
8. Fuel Filter Warning Indicator Light - Illuminates when there is water in the fuel filter. When this indicator illuminates the engine will shut off automatically. Service of the fuel filter will be required.
9. Engine Warning Indicator Light - Will illuminate when there is a fault detected in the engine control system. This indicator light will be illuminate, either continuously or blinking, depending on engine fault. See **3-9** for a detailed explanation of engine warning indicator light operation.
10. Low fuel level warning indicator - When the fuel in the fuel tank is under minimum level, this indicator shall be ON.

NOTICE: If this indicator turns on, fill the fuel tank immediately with fuel.

11. Battery Charge Warning Light - Illuminates when the key switch is in the "ON" position and goes out when the operator starts the engine. An illuminated bulb during this operation indicates the charging system is not operating normally.
12. Engine Oil Pressure Warning Light - Illuminates with the key switch in the "ON" position and remains illuminated for a short period, after you start the engine. The light indicates low engine oil pressure only and goes out when sufficient oil pressure is present at the oil sender. If the bulb illuminates during operation, stop the tractor immediately, and investigate the cause.

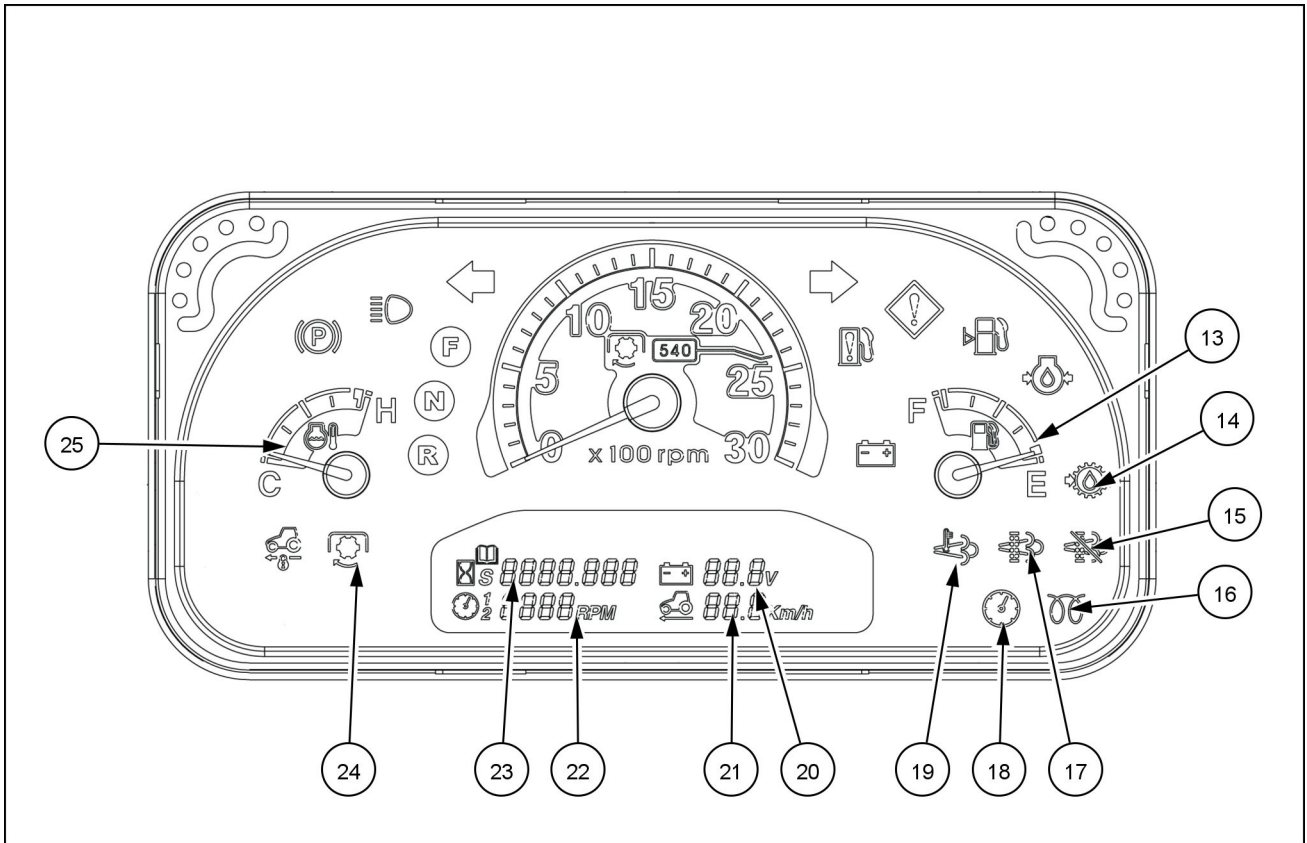

NHIL16CT00387FA 2

13. Fuel Gauge - Indicates the amount of diesel fuel remaining in the tank. The gauge will activate when the key switch is in the "ON" position. It will register "empty" with the key switch in the "OFF" position.
14. Hydraulic oil pressure indicator (Not used)
15. Diesel Particulate Filter (DPF) Inhibited Indicator Light - This indicator light will illuminate when you place the (DPF) switch in the inhibited position, to indicate the regeneration of the (DPF) stops.
16. Cold Starting Indicator Light - Illuminates when the key switch is first turned to the "ON" position. The illumination time will vary from three to twelve seconds, depending on the ambient temperature. When the indicator light is illuminated, the glow plugs are heating the engine combustion chambers.
17. Diesel Particulate Filter (DPF) Regeneration Indicator Light - This indicator light will be illuminated either continuous or blinking, when the regeneration of the (DPF) is in operation. The regeneration starts when the (DPF) soot load is at 100% and the engine exhaust temperature is at a sufficient temperature for regeneration to start. See **4-2** for more information.
18. Engine Speed Control (ESC) mode indicator - This indicator activates when operating ESC main switch to ON position and Engine Speed Control (ESC) is ready.
19. Diesel Particulate Filter (DPF) Temperature Indicator Light - This indicator light will be illuminated when the engine exhaust temperature is sufficient for the regeneration of the (DPF) to start.
20. Battery voltage - This will display available battery voltage.
21. Speedometer (Not used)
22. Engine Speed Control (ESC) and FMI code - The RPM stored on ECU for Engine Speed Cruise Control (ESC) displays in normal status. If any errors related to the Tier-4 engine control happened, FMI code to be able to know the error type or pattern shall be displayed by turns additionally with Engine diagnosis error codes(9).
23. Hour Meter - Records the hours and portions of hours that your tractor has accumulated regardless of engine RPM. Use the hour meter as a guide to determine hourly service and maintenance intervals.
24. PTO Indicator Light - When either the rear or mid PTO is engaged, the indicator will be illuminated amber with the key in the "START" or "ON" positions.
25. Temperature Gauge - Indicates coolant temperature. It activates when you turn the key switch to the "ON" position. The gauge will register cold with the key switch in the "OFF" position. If the needle registers in the white

range of the gauge, this indicates a normal operating temperature. If the needle moves to the red portion of the gauge, this indicates an overheated condition. Stop the tractor engine immediately and investigate the cause.

Engine fault code display

Introduction

The following information is intended as a guide to assist in identifying and correcting possible tractor malfunctions and fault conditions.

Fault codes

Your tractor makes extensive use of electronics to control and monitor major components within the engine and emissions control systems. In the unlikely event of a fault occurring in one of these areas, the malfunction will be identified with a "sxxxx" (3) and "Fxx" (2) code displayed on the instrument panel. The Warning Lamp (1) will also be illuminated in amber or red color.

Should a fault occur causing the tractor to become disabled, a fault code will be displayed in the instrument panel. Contact your authorized NEW HOLLAND dealer and report the fault code displayed.

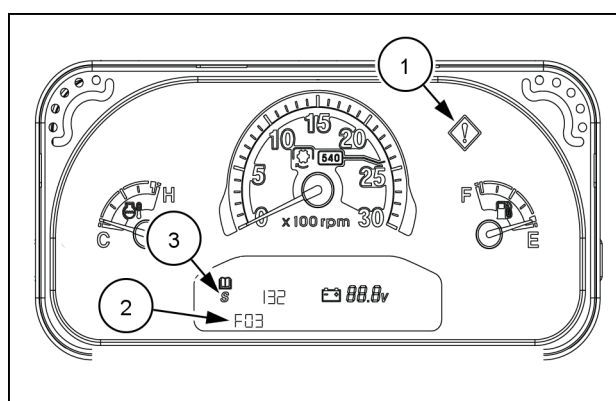

NHILCT1700115AA 1

Reference	Dashboard Fault Code	Fault Code	Warning Lamp		Title
			Amber	Red	
1	s629 F12	P060B		Solid on or 1 Hz	Analog Digital Converter (ADC) Circuit Fault inside of ECU
2	s132 F31	P0100		Solid on	Air Mass Flow (AMF) Sensor Failure
3	s132 F00 s132 F01	P0101		Solid on	Air Mass Flow (AMF) plausibility fault
4	s132 F03	P0103		Solid on	Air Mass Flow (AMF) Sensor high fault
5	s132 F04	P0102		Solid on	Air Mass Flow (AMF) Sensor low fault
6	s637 F02	P0341	Solid on	Solid on	Cam signal drift fault
7	s637 F10	P0340	Solid on		Cam signal learn fault
8	s636 F02	P0371		Solid on	Crank signal early fault
9	s636 F02	P0374		Solid on	Crank signal lost fault
10	s636 F02	P0372		Solid on	Crank signal missing fault
11	s636 F02 s636 F11	P0335	Solid on	Solid on	Crank over speed / gap lost fault
12	s108 F03	P2229		Solid on	Atmospheric pressure sensor high fault
13	s108 F04	P2228		Solid on	Atmospheric pressure sensor low fault
14	s168 F03	P0563	Solid on		Battery voltage high fault
15	s168 F04	P0562	Solid on		Battery voltage low fault
16	s651 F31	P0262		Solid on	Injector 1 resistance high fault
17	s653 F31	P0268		Solid on	Injector 2 resistance high fault
18	s654 F31	P0271		Solid on	Injector 3 resistance high fault
19	s652 F31	P0265		Solid on	Injector 4 resistance high fault
20	s651 F31	P0261		Solid on	Injector 1 resistance low fault

3 - CONTROLS AND INSTRUMENTS

Reference	Dashboard Fault Code	Fault Code	Warning Lamp		Title
			Amber	Red	
21	s653 F31	P0267		Solid on	Injector 2 resistance low fault
22	s654 F31	P0270		Solid on	Injector 3 resistance low fault
23	s652 F31	P0264		Solid on	Injector 4 resistance low fault
24	s630 F11	P0602		2 Hz	Injector code fault
25	s110 F02	P0116		Solid on	Coolant sensor plausibility fault
26	s110 F02	P0119		Solid on	Coolant sensor gradient fault
27	s110 F03	P0118		Solid on	Coolant sensor high fault
28	s110 F04	P0117		Solid on	Coolant sensor low fault
29	s110 F04	P0115		Solid on	Coolant sensor fault (global)
30	s3253 F07	P224A	Solid on		Differential Pressure (DP) sensor leak detected
31	s3253 F11	P1453	Solid on		Differential Pressure (DP) sensor tube Clamped
32	s3253 F11	P1452	Solid on		Differential Pressure (DP) sensor tube inverted
33	s3253 F02	P2453	Solid on		Differential Pressure (DP) sensor plausibility fault
34	s3253 F03	P2455	Solid on		Differential Pressure (DP) sensor high fault
35	s3253 F04	P2454	Solid on		Differential Pressure (DP) sensor low fault
36	s173 F31	P242A	Solid on		Diesel Particulate Filter (DPF) In temp sensor fault
37	s173 F03	P242D	Solid on		Diesel Particulate Filter (DPF) In temp sensor high fault
38	s173 F04	P242C	Solid on		Diesel Particulate Filter (DPF) In temp sensor low fault
39	s173 F02	P242E	Solid on		Diesel Particulate Filter (DPF) In temp sensor noise fault
40	s173 F02	P242B	Solid on		Diesel Particulate Filter (DPF) In temp sensor plausibility fault
41	s81 F00	P2458	Solid on or 2 Hz		Diesel Particulate Filter (DPF) overload fault
42	s81 F07	P2463		Solid on or 2 Hz	Diesel Particulate Filter (DPF) plugged fault
43	s81 F11	P242F	1 Hz		Diesel Particulate Filter (DPF) regeneration error
44	s1485 F07 s1485 F11	P0685	Solid on or 2 Hz		Main relay fault
45	s27 F10 s27 F31	P0C18		Solid on or 1 Hz	Exhaust Gas Recirculation (EGR) position learning fault
46	s27 F08	P0404		Solid on or 1 Hz	Exhaust Gas Recirculation (EGR) position control fault
47	s27 F02	P0402		Solid on	Exhaust Gas Recirculation (EGR) airflow error too high
48	s27 F02	P0401		Solid on	Exhaust Gas Recirculation (EGR) airflow error too low
49	s27 F03	P0406		Solid on	Exhaust Gas Recirculation (EGR) position sensor high fault
50	s27 F04	P0405		Solid on	Exhaust Gas Recirculation (EGR) position sensor low fault
51	s27 F02	P046D		Solid on	Exhaust Gas Recirculation (EGR) position sensor noise fault

3 - CONTROLS AND INSTRUMENTS

Reference	Dashboard Fault Code	Fault Code	Warning Lamp		Title
			Amber	Red	
52	s27 F03 s27 F04 s27 F05 s27 F11 s27 F16	P0403		Solid on	Exhaust Gas Recirculation (EGR) H-Bridge driver fault
53	s1221 F11	P061B		Solid on or 2 Hz	Engine Control Unit (ECU)-Zero Torque Monitoring fault
54	s1221 F11	P1606	Solid on		Engine Control Unit (ECU)- Supplementary fault 1
55	s1221 F11	P1607	Solid on		Engine Control Unit (ECU)- Supplementary fault 2
56	s1221 F11	P1611	Solid on		Engine Control Unit (ECU)-injector drive disable fail fault
57	s1221 F11	P16D6	Solid on		Engine Control Unit (ECU)-engine speed fault
58	s1221 F11	P160C		Solid on or 2 Hz	Engine Control Unit (ECU)-engine off fault
59	s1221 F11	P1978	Solid on		Engine Control Unit (ECU)- Electronic Speed Control (ESC) Time out fault
60	s1221 F11	P1612	Solid on		Engine Control Unit (ECU)-injector drive disable fault
61	s1221 F11	P16D8	Solid on		Engine Control Unit (ECU)-Pedal monitoring fault
62	s1221 F11	P1602	Solid on		Engine Control Unit (ECU)-Processor Code Fault
63	s1221 F11	P1601	Solid on		Engine Control Unit (ECU)-Processor Data Fault
64	s1221 F11	P1604	Solid on		Engine Control Unit (ECU)-Processor Random Access Memory (RAM) Fault
65	s1221 F11	P162B	Solid on		Engine Control Unit (ECU)-injector drive lock fail fault
66	s1221 F11	P1620	Solid on		Engine Control Unit (ECU)-L2 trip fault
67	s1221 F11	P1621	Solid on		Engine Control Unit (ECU)-L3 trip fault
68	s1221 F11	P1622	Solid on		Engine Control Unit (ECU)-Engine Control Unit (ECU) reset fail fault
69	s1221 F11	P1623	Solid on		Engine Control Unit (ECU)-injection locking fault
70	s1221 F11	P1624		Solid on or 2 Hz	Engine Control Unit (ECU)-Nominal mode fault
71	s1221 F11	P160E		Solid on or 2 Hz	Engine Control Unit (ECU)-Hand pedal fault
72	s1221 F11	P160D		Solid on or 2 Hz	Engine Control Unit (ECU)-Foot pedal fault
73	s1221 F11	P1625	Solid on		Engine Control Unit (ECU)- Background Flow Check failure
74	s1221 F11	P1626	Solid on		Engine Control Unit (ECU)- Background Cycle Check failure
75	s1221 F11	P1627	Solid on		Engine Control Unit (ECU)-Program Flow check failure
76	s1221 F11	P1628	Solid on		ECU-Program Flow cycle check
77	s1221 F11	P1630	Solid on		Engine Control Unit (ECU)-Pulse check bank error
78	s1221 F11	P1631	Solid on		Engine Control Unit (ECU)-Pulse check injector code correction error

3 - CONTROLS AND INSTRUMENTS

Reference	Dashboard Fault Code	Fault Code	Warning Lamp		Title
			Amber	Red	
79	s1221 F11	P1632	Solid on		Engine Control Unit (ECU)-Pulse check injector number error
80	s1221 F11	P1633	Solid on		Engine Control Unit (ECU)-Pulse check fuel quantity error
81	s1221 F11	P1634	Solid on		Engine Control Unit (ECU)-Pulse check injection number error
82	s1221 F11	P1635	Solid on		Engine Control Unit (ECU)-Pulse check OFF error
83	s1221 F11	P1636	Solid on		Engine Control Unit (ECU)-Pulse check ON error
84	s1221 F11	P1637	Solid on		Engine Control Unit (ECU)-Pulse check tooth error
85	s1221 F11	P1638	Solid on		Engine Control Unit (ECU)-Pulse check injection type error
86	s1221 F11	P1660	Solid on		Engine Control Unit (ECU)-L1/L2 pulses comparison fault 1
87	s1221 F11	P1661	Solid on		Engine Control Unit (ECU)-L1/L2 pulses comparison fault 2
88	s1221 F11	P1662	Solid on		Engine Control Unit (ECU)-injection lock fail after a power latch
89	s1221 F11	P1663	Solid on		Engine Control Unit (ECU)-Reset fail after a power latch
90	s1221 F11	P160B	Solid on		Engine Control Unit (ECU)-Queue Analogue To Digital Converter(QADC) multiplexor fault
91	s1221 F11	P1690	Solid on		Engine Control Unit (ECU)-Queue Analogue To Digital Converter(QADC) slope high fault
92	s1221 F11	P1691	Solid on		Engine Control Unit (ECU)-Queue Analogue To Digital Converter(QADC) slope low fault
93	s1221 F11	P1692	Solid on		Engine Control Unit (ECU)-Question (QST) timeout fault
94	s1221 F11	P16D2		Solid on or 2 Hz	Engine Control Unit (ECU)-Reduced torque mode fault
95	s1221 F11	P1219		Solid on or 2 Hz	Engine Control Unit (ECU)-Engine Control Unit (ECU) Software Monitoring fault
96	s173 F00	P2428		Solid on	Exhaust over temperature fault
97	s731 F11	P0325	Solid on		Accelerometer 1 fault
98	s731 F11	P0330	Solid on		Accelerometer 2 fault
99	s1612 F03 s1612 F06 s1612 F11	P062D	Solid on or 1 Hz	Solid on	Injector Bank 1 fault
100	s1613 F03 s1613 F06 s1613 F11	P062E	Solid on or 1 Hz	Solid on	Injector Bank 2 fault
101	s651 F05 s651 F06	P0201		Solid on	Injector 1 Circuit fault
102	s653 F05 s653 F06	P0203		Solid on	Injector 2 Circuit fault
103	s654 F05 s654 F06	P0204		Solid on	Injector 3 Circuit fault
104	s652 F05 s652 F06	P0202		Solid on	Injector 4 Circuit fault

3 - CONTROLS AND INSTRUMENTS

Reference	Dashboard Fault Code	Fault Code	Warning Lamp		Title
			Amber	Red	
105	s675 F03 s675 F05 s675 F06 s675 F31	P2687	Solid on		Fuel heater driver fault
106	s174 F02	P0181		Solid on	Fuel temp sensor gradient fault
107	s174 F03	P0183		Solid on	Fuel temp sensor high fault
108	s174 F03	P0182		Solid on	Fuel temp sensor low fault
109	s676 F05	P0380	Solid on		Glow Plug (GP) relay open circuit fault
110	s676 F04	P0383	Solid on		Glow Plug (GP) relay short circuit to ground fault
111	s676 F03	P0384	Solid on		GP relay short circuit to source fault
112	s1076 F31	P0254		Solid on	Inlet Metering Valve (IMV) current trim drift fault
113	s157 F11 s1076 F03 s1076 F04 s1076 F16 s1076 F18	P0002		Solid on or 1 Hz	Inlet Metering Valve (IMV) control fault
114	s1076 F03	P0004		Solid on or 1 Hz	Inlet Metering Valve (IMV) control feedback high fault
115	s1076 F04	P0003		Solid on or 1 Hz	Inlet Metering Valve (IMV) control feedback low fault
116	s1076 F05	P0001		Solid on or 1 Hz	Inlet Metering Valve (IMV) driver signal open circuit fault
117	s172 F02	P0074		Solid on	Inlet Air Temp sensor signal gradient fault
118	s172 F03	P0073		Solid on	Inlet Air Temp sensor signal high fault
119	s172 F04	P0072		Solid on	Inlet Air Temp sensor signal low fault
120	s5202 F31	U0140	Solid on		Controller Area Network (CAN) message Time-out fault
121	s106 F03 s106 F04	P0106		Solid on	Intake Manifold Absolute Pressure sensor signal drift fault
122	s106 F03	P0108		Solid on	Intake Manifold Absolute Pressure sensor signal high fault
123	s106 F04	P0107		Solid on	Intake Manifold Absolute Pressure sensor signal low fault
124	s0651 F31	P029B	Solid on		Injector 1 Minimum Drive Pulse (MDP) value low fault
125	s653 F31	P02A3	Solid on		Injector 2 Minimum Drive Pulse (MDP) value low fault
126	s654 F31	P02A7	Solid on		Injector 3 Minimum Drive Pulse (MDP) value low fault
127	s652 F31	P029F	Solid on		Injector 4 Minimum Drive Pulse (MDP) value low fault
128	s654 F31	P1311		Solid on	no Minimum Drive Pulse (MDP) updates occur fault 1
129	s654 F31	P1303		Solid on	no Minimum Drive Pulse (MDP) updates occur fault 2
130	s651 F31	P029A	Solid on		Injector drift fault detection on Injector 1
131	s653 F31	P02A2	Solid on		Injector drift fault detection on Injector 2
132	s654 F31	P02A6	Solid on		Injector drift fault detection on Injector 3
133	s652 F31	P029E	Solid on		Injector drift fault detection on Injector 4

3 - CONTROLS AND INSTRUMENTS

Reference	Dashboard Fault Code	Fault Code	Warning Lamp		Title
			Amber	Red	
134	s630 F02	P0605	Solid on		ECU memory integrity fault - code
135	s630 F02	P0603	Solid on		ECU memory integrity fault - data / calibration
136	s630 F02	P0604	Solid on		ECU memory integrity fault - RAM
137	s94 F11	P0088		Solid on or 1 Hz	Rail pressure control fault
138	s630 F11	P062F		Solid on or 1 Hz	ECU non volatile memory fault
139	s91 F31	P2135		Solid on or 1 Hz	Foot Pedal Correlation track 1 over track 2 fault
140	s91 F31	P060D		Solid on or 1 Hz	Foot pedal signal fault
141	s91 F31	P0120		Solid on or 1 Hz	Foot pedal signal track 1 fault
142	s91 F31	P0220		Solid on or 1 Hz	Foot pedal signal track 2 fault
143	s29 F31	P2138		Solid on or 1 Hz	Hand pedal correlation track 1 over track 2 fault
144	s29 F31	P060E		Solid on or 1 Hz	Hand pedal signal fault
145	s29 F31	P2120		Solid on or 1 Hz	Hand pedal signal track 1 fault
146	s29 F31	P2125		Solid on or 1 Hz	Hand pedal signal track 2 fault
147	s157 F03 s157 F04 s157 F11 s157 F31	P0191		Solid on or 1 Hz	Rail pressure sensor fault (global)
148	s157 F01	P0093		Solid on or 1 Hz	Rail pressure sensor signal drop fault
149	s157 F02	P0190		Solid on or 1 Hz	Rail pressure sensor signal grad fault
150	s157 F03	P0193		Solid on or 1 Hz	Rail pressure sensor signal high fault
151	s157 F04	P0192		Solid on or 1 Hz	Rail pressure sensor signal low fault
152	s157 F10	P0087		Solid on	Rail Pressure build normal fault
153	s157 F11	P0089		Solid on or 1 Hz	Rail pressure control error during 'RVD-Only' control
154	s677 F31	P0615	Solid on		Starter motor relay global driver fault
155	s677 F03 s677 F05	P0617	Solid on		Starter motor control relay - short circuit to ground detected
156	s677 F04	P0616	Solid on		Starter motor control relay - short open circuit/short circuit to battery detected
157	s105 F03	P0113		Solid on	Intake manifold temp sensor high fault
158	s105 F04	P0112		Solid on	Intake manifold temp sensor low fault
159	s105 F02	P0114		Solid on	Intake manifold temp sensor noise fault
160	s105 F02	P0111		Solid on	Intake manifold temp sensor plausibility fault
161	s51 F07	P02E1	Solid on		Air Control Valve (ACV) control fault
162	s51 F03	P02E9	Solid on		Air Control Valve (ACV) position signal high fault
163	s51 F04	P02E8	Solid on		Air Control Valve (ACV) position signal low fault

3 - CONTROLS AND INSTRUMENTS

Reference	Dashboard Fault Code	Fault Code	Warning Lamp		Title
			Amber	Red	
164	s51 F11	P02EB	Solid on		Air Control Valve (ACV) driver fault (current)
165	s51 F05	P02E0	Solid on		Air Control Valve (ACV) driver open circuit
166	s51 F16 s51 F18	P02FA	Solid on		Air Control Valve (ACV) driver fault(current)
167	s51 F04	P02E2	Solid on		Air Control Valve (ACV) driver short circuit to Ground
168	s51 F03	P02E3	Solid on		Air Control Valve (ACV) driver short circuit to Battery
169	s51 F10	P02E7	Solid on		Air Control Valve (ACV) learning position fault
170	s1180 F31	P0544		Solid on	Exhaust Manifold temp fault
171	s1180 F03	P0546		Solid on	Exhaust Manifold temp sensor high fault
172	s1180 F04	P0545		Solid on	Exhaust Manifold temp sensor low fault
173	s1180 F02	P2081		Solid on	Exhaust Manifold temp sensor noise fault
174	s1180 F02	P2080		Solid on	Exhaust Manifold temp sensor plausibility fault
175	s1079 F11	P0641		Solid on or 1 Hz	Engine Control Unit (ECU) Internal 5V Supply 1 fault
176	s1080 F11	P0651		Solid on or 1 Hz	Engine Control Unit (ECU) Internal 5V Supply 2 fault
177	s1080 F11	P0697		1 Hz	Engine Control Unit (ECU) Internal 5V Supply 2 auxiliary fault
178	s97 F03 s97 F04	P2264		Solid on	Water in fuel sensor fault
179	s97 F02 s97 F11	P2269		Solid on	Water in fuel detect
180	s100 F02	P0522		2 Hz	Engine oil pressure fault

Hydrostatic transmission - Operate

⚠ WARNING

Loss of control hazard!

To maintain optimum control of the machine, do not use the cruise control at high speeds or when loading.

Failure to comply could result in death or serious injury.

W0978A

The HST cruise control lever (1) is located on the right-hand side of the operator's platform. It is used to maintain a constant forward speed.

NOTE: The cruise control is only found on HST model tractors.

When the desired travel speed is reached, push downwards on the cruise control engagement lever while depressing the HST forward pedal (2). The engagement lever will mechanically retain the forward pedal in the desired speed location. To disengage the cruise control, depress the HST forward pedal slightly or depress both brake pedals (3).

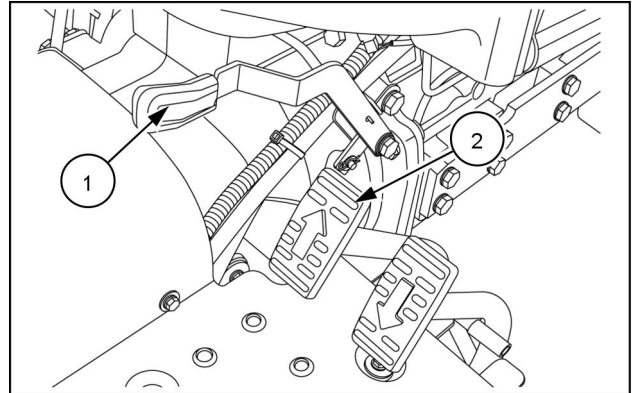

NHIL12CT00693AA 1

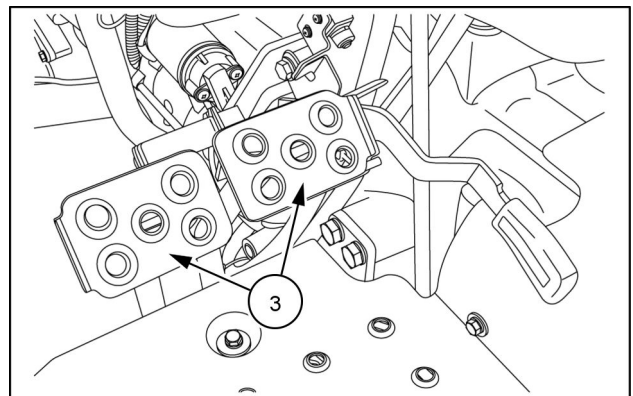

NHIL12CT00691AA 2

Shuttle lever

NOTICE: The synchro-shuttle shift lever allows any forward or reverse range to be shifted while the tractor is moving slowly. However, the clutch must be disengaged and engaged by means of the clutch pedal. Depress the clutch pedal fully and release gradually to take up load smoothly. Sudden gear shifting may cause transmission damage. It is recommended to stop the tractor before operating the shuttle lever.

NOTE: The shuttle shift lever is only found on mechanical model tractors.

The transmission shuttle shift lever **(1)** is located on the left-hand side of the dash panel. The shuttle shift lever is used to engage the transmission into forward or reverse mode while depressing the clutch pedal. Move the lever forward for forward travel and rearward for reverse travel.

NOTE: The shuttle lever must be in the neutral (middle) position to activate the safety start system, which allows the engine to start.

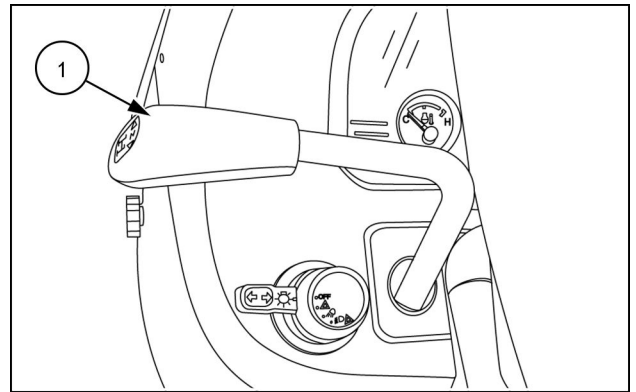

93099335 1

Clutch pedal

The foot operated clutch pedal (1) controls the single-stage clutch and is located on the left-hand side of the operators platform.

NOTE: The clutch pedal is only found on mechanical model tractors.

Always depress the clutch pedal fully when engaging or disengaging the front-wheel drive.

To start the tractor, depress the clutch pedal fully to ensure a safe start-up.

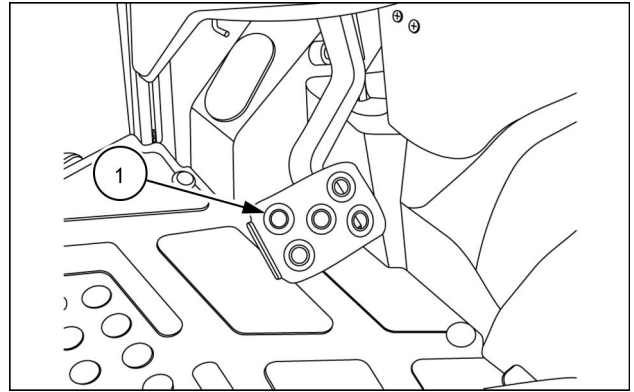

93099348 1

Brake pedal

⚠ WARNING

Loss of control hazard!

Uneven brake force exists on left-hand and right-hand brakes. To ensure uniform brake application and maximum stopping ability, always lock the service brake pedals together before road travel.

Failure to comply could result in death or serious injury.

W1188A

The right brake pedal controls the braking action of the right rear wheel. The left brake pedal controls the braking action of the left rear wheel.

The function of the brake pedals are identical for the HST and Mechanical transmission model tractors except for the location of the pedals. The brake pedals **(1)** on a HST model tractor are located on the left-hand side of the operators platform and the brake pedals **(2)** on a mechanical model tractor are located on the right-hand side of the operators platform.

Depress both pedals simultaneously to stop the tractor. To assist in making sharp turns at slow speed, depress the right or left brake pedal as required.

The brake pedal connecting pin **(3)** is used to secure the brake pedals together. Lock the pedals together whenever the tractor is operated at high speeds or when the tractor is used on the highway.

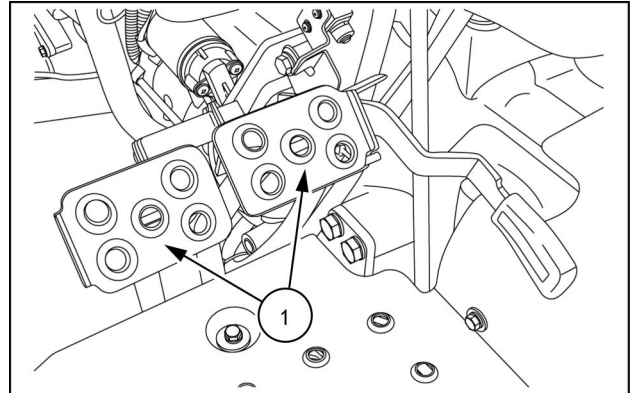

NHIL12CT00691AA 1

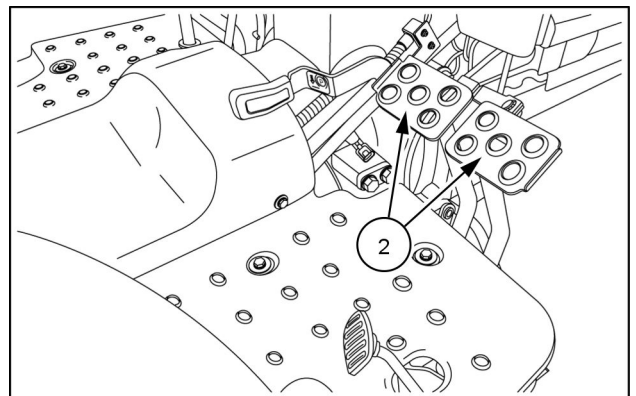

NHIL13CT00044AA 2

Foot throttle pedal

The foot throttle pedal (1) may be used independent of the hand throttle lever to control the speed of the tractor.

NOTE: The foot throttle pedal is found only on mechanical model tractors.

NOTE: It is recommended to use the foot throttle pedal when driving on the main road or highway.

NOTE: When using the foot throttle pedal, the hand throttle lever should be in the (low idle) rearward position.

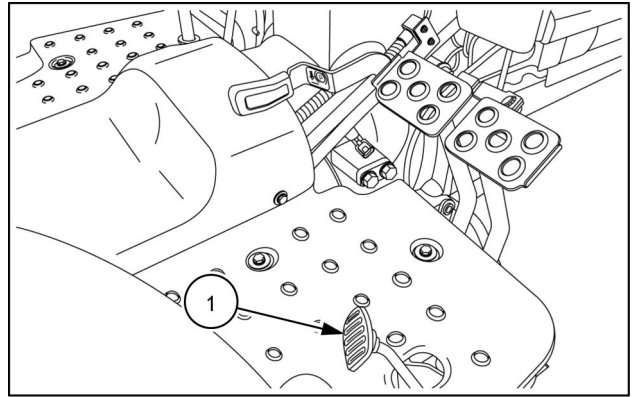

NHIL13CT0004AA 1

Hand throttle lever

The hand throttle lever (1) is located on the right-hand side of the dash panel.

Push the lever forward to increase the engine speed and rearward to decrease the engine speed.

NOTE: The hand throttle lever should only be used during field operation.

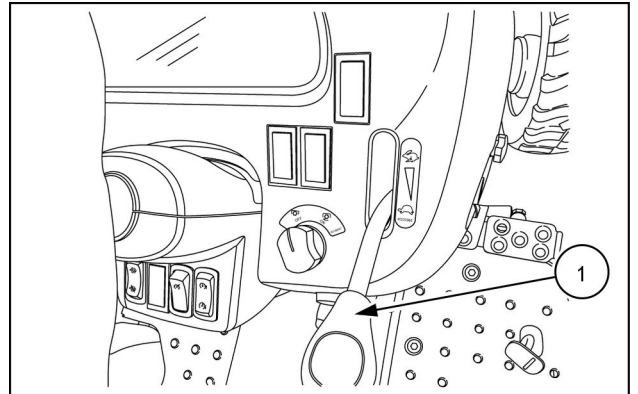

NHIL17CT00211AA 1

Horn switch (optional)

The (optional) horn switch (1) would be located on the center of the steering wheel shroud.

To activate the horn, place the key switch in the "ON" position and push the horn switch down.

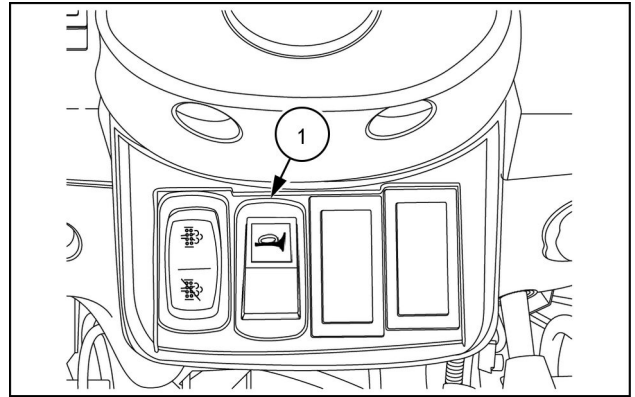

NHIL15CT00337AA 1

Power Take-Off (PTO) switch

The PTO switch (1) is located on the right-hand side of the dash panel.

NOTE: To start the engine the PTO switch must be placed in the "OFF" position

To activate the PTO, push down on the PTO switch and turn the switch to the "ON" position (A).

When the PTO is engaged the PTO indicator light (2) will be illuminated on the instrument panel.

To disengage the PTO, push down on the PTO switch and the switch will automatically return to the "OFF" position (B).

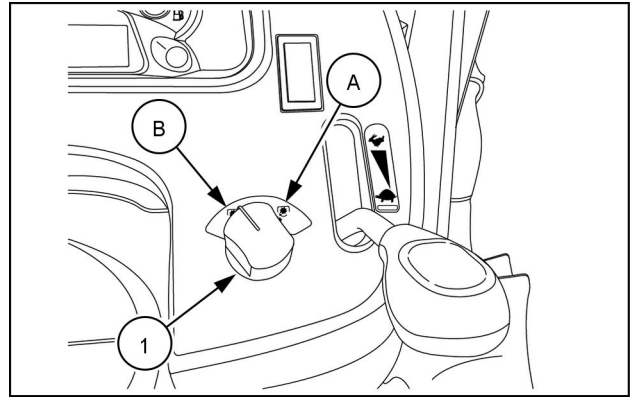

NHIL15CT00352AA 1

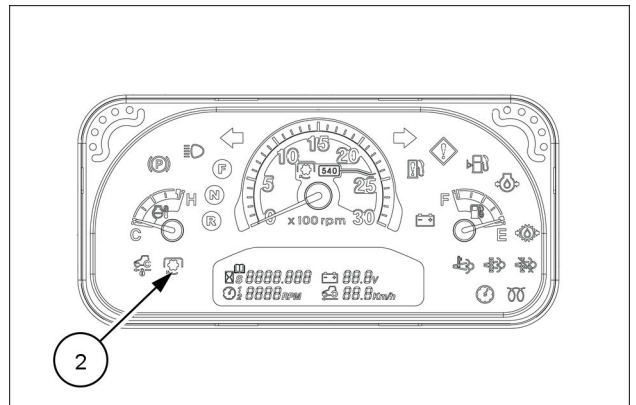

NHIL16CT00387FA 2

Key switch

The key switch (1) is located on the right-hand side of the rear hood panel.

The key switch has three positions.

- A. (STOP / OFF) This position will shut off the engine.
- B. (ON / RUN) This position activates the warning lights, instruments, and automatic engine preheat system
- C. (START) This position engages the engine starter. When key is released an internal spring returns the key to the ON / RUN position.

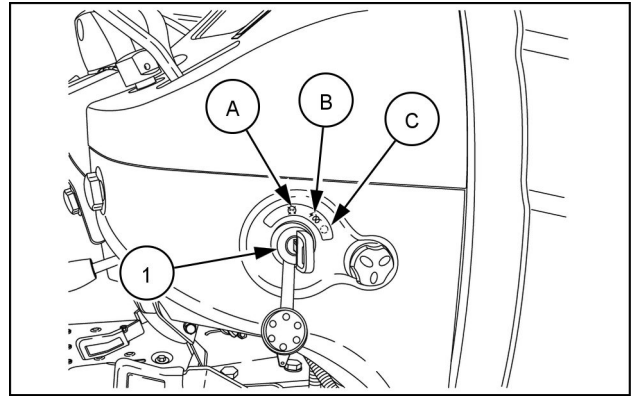

NHIL15CT00472AA 1

Differential lock lever - Operating

⚠ WARNING

Steering is difficult with the differential lock engaged. An accident could result. During field operation, use the differential lock for traction improvement but release for turning at row end. Do not drive at high speeds or on roads with the differential lock engaged. Failure to comply could result in death or serious injury.

W0292A

The differential lock pedal is located on the left-hand foot platform (1) on HST models and on the right-hand foot platform (2) on mechanical models. The differential lock is used to obtain additional traction in wet or loose soil.

When the differential lock pedal is depressed, both final drive pinion gear shafts are locked together, preventing one wheel from rotating independently of the other. Whenever one wheel begins to slip in wet or loose soil, use the lock to obtain additional traction from the opposite wheel.

To operate the differential lock, depress and hold the pedal down until the lock is positively engaged. It is best to engage the lock while the wheels are turning slowly to minimize shock loads to the driveline. If a wheel spins at high speed, such as on ice, reduce engine speed to idle before engaging the lock or damage may result. Release the pedal to disengage the differential lock.

NOTE: In some instances, the lock may remain engaged after the pedal is released. This can occur if one rear wheel is turning at a faster speed than the other. The lock can be disengaged in one of two ways if this occurs:

- Decrease the drawbar pull by raising or disengaging the implement so that neither wheel tends to slip.
- Depress the clutch pedal and rapidly apply and release a light braking load to the wheel with less traction.

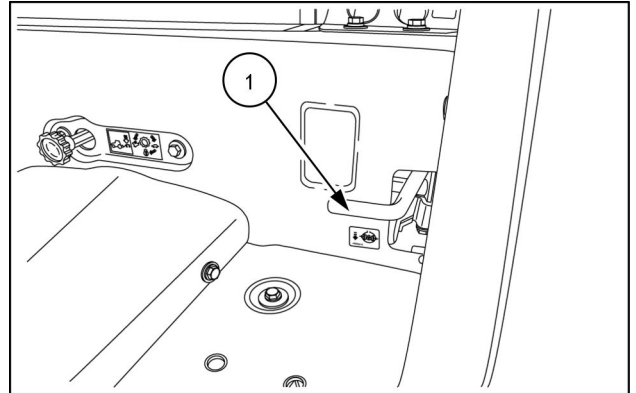

NHIL12CT00687AA 1

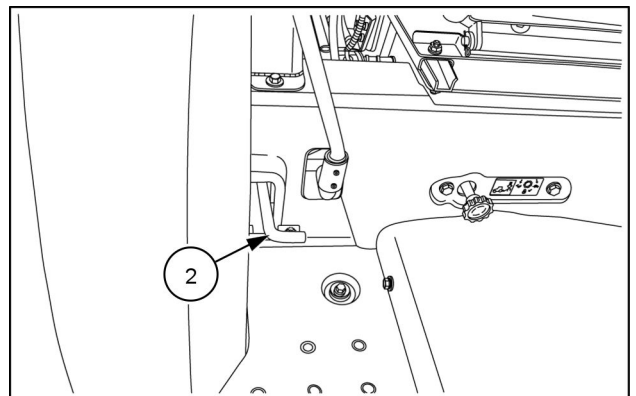

NHIL13CT00039AA 2

Hydrostatic transmission pedal - Operating

The ground speed of tractors equipped with a hydrostatic transmission, (HST) is continuously variable, from zero to full rated speed in each range. Speed is controlled by the HST forward **(1)** and reverse **(2)** pedals located on the right-hand foot platform.

For forward travel, depress the forward pedal **(1)** until the desired ground speed is reached. For reverse travel, depress the rear pedal **(2)**. Unless the HST cruise control switch is in the "ON" position, the transmission returns to neutral and the tractor stops when the pedal is released.

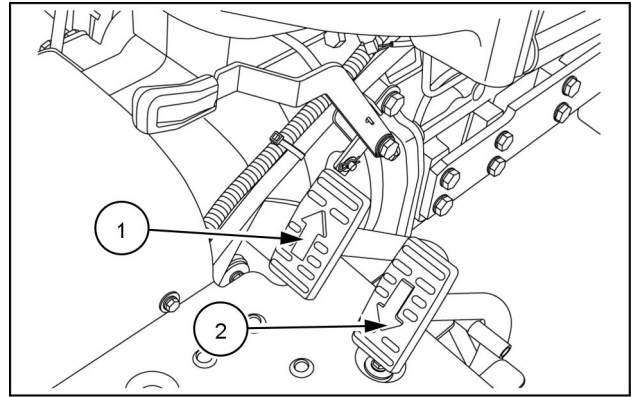

NHIL12CT00693AA 1

Tilt steering lever - Operating

The tilt steering lever (1) is located on the right-hand side of the steering column shroud.

The tilt steering lever is used to adjust the steering wheel position.

To adjust position of steering wheel:

1. Push downwards (A) on lever (1) and position steering wheel as needed.
2. Pull upwards (B) on tilt steering lever to lock steering wheel in place

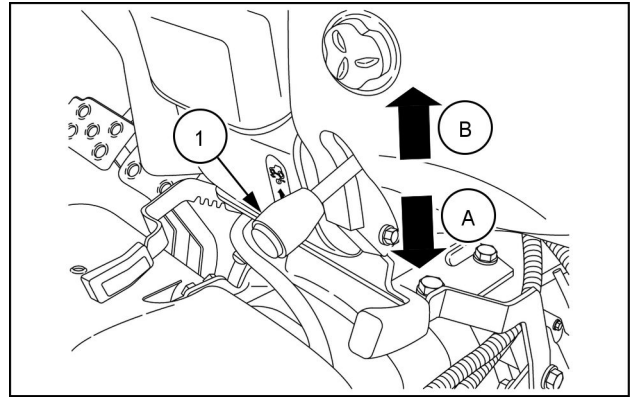

NHIL15CT00248AA 1

Multifunction light switch

The multifunction light switch (1) is located on the left-hand side of the dash panel and is used to control the following lighting functions:

- Hazard lights
- Taillights
- Front work lights
- Front road lights
- Turn signals

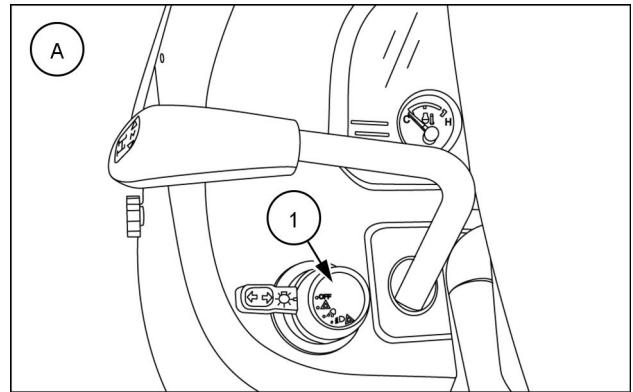

93099335 1

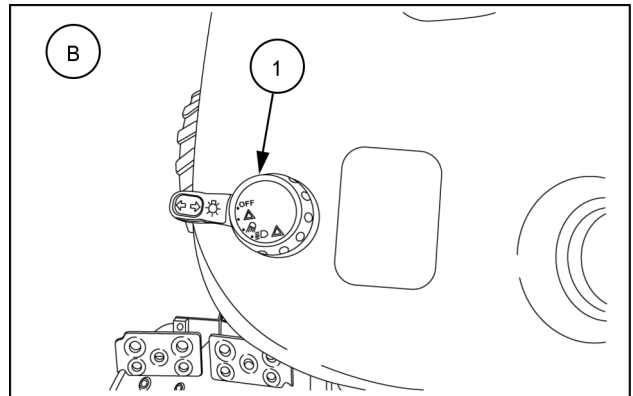

NHIL12CT00669AA 2

- (A) MECHANICAL MODEL
(B) HST MODEL

Engine Speed Management (ESM) switch

This switch (1) enables the Engine Speed Management (ESM) function.

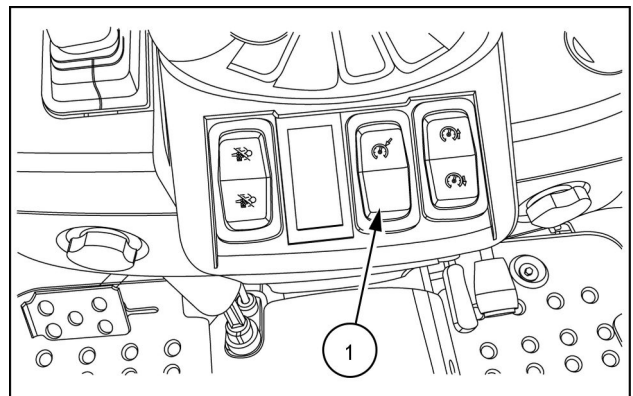

NHIL17CT00213AA 1

Engine Speed Management (ESM) Up/Down switch

The ESM up/down switch (1) is used to adjust the engine speed for ESM when the ESM is enabled.

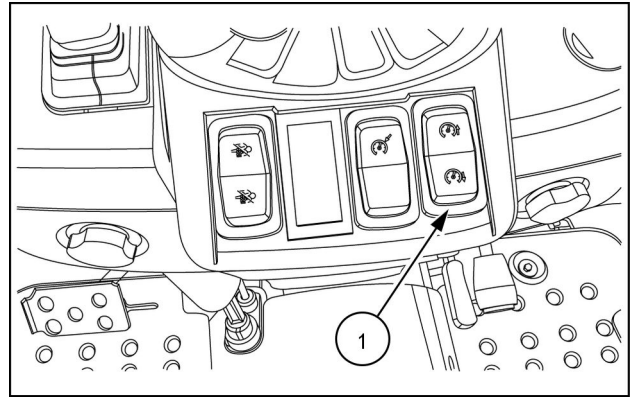

NHIL17CT00213AA 1

DPF switch

The (DPF) switch (1) located on the left-hand side of the dash, is used to delay or stop the regeneration of the (DPF) emission system.

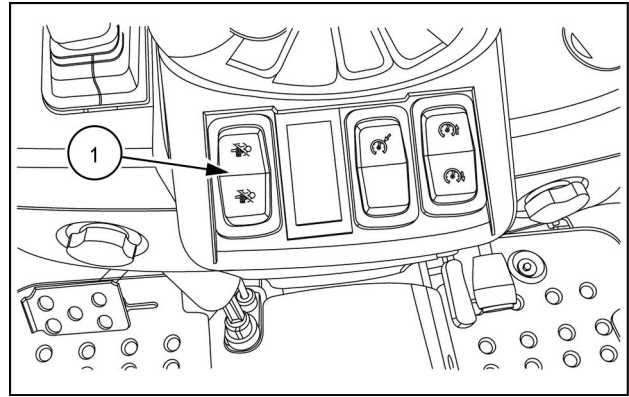

NHIL17CT00213AA 1

Left-hand side controls

Transmission range lever

The transmission range selector lever (1) is located on the left-hand control pod. There are three speed ranges, (H) High, (M) Medium, and (L) Low. The transmission range selector lever on HST models (A) has a neutral position between the H and M positions, mechanical models (B) do not.

NOTICE: Never attempt to engage or disengage the range lever when the tractor is in motion.

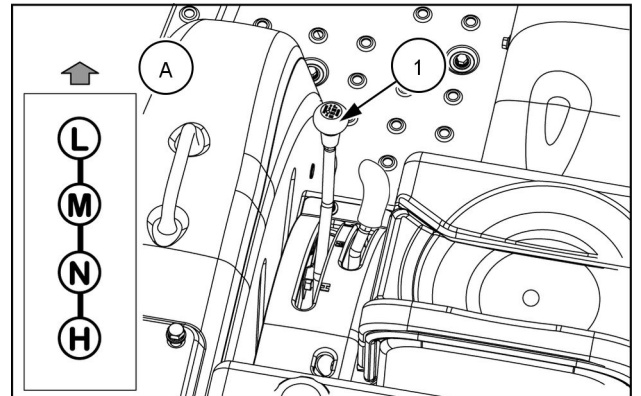

NHIL12CT01098AA 1

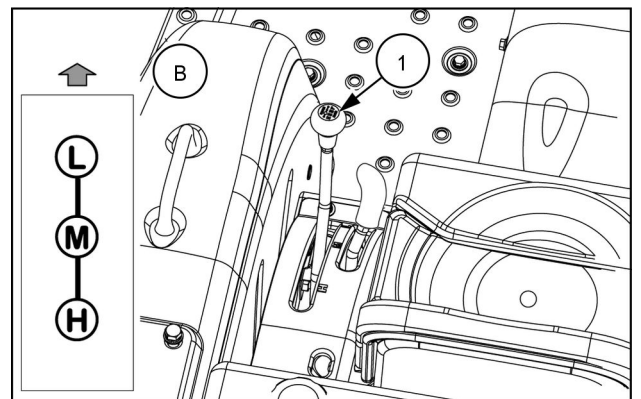

NHIL12CT01097AA 2

- (A) HST MODEL
- (B) MECHANICAL MODEL

Park brake

⚠ WARNING

Unexpected machine movement!
Always engage the parking brake before exiting the machine.
Failure to comply could result in death or serious injury.

W1011B

NOTICE: Ensure the park brake is fully disengaged before driving the tractor.

The park brake lever (1) is located on the left-hand side of the operators platform on HST model tractors (A) and on the right-hand side on mechanical model tractors (B). The park brake is used to secure the brake pedals together to prevent the tractor from moving while parked.

To engage the park brake, lock the pedals together and push the park brake lever downward while depressing the brake pedals.

NOTE: Always engage the park brake when getting off the tractor. If the brakes are not engaged or the operator leaves the seat without engaging the park brake a alarm will sound. The alarm will continue to sound for approximately ten seconds or until the park brake is engaged.

To disengage the park brake, press the brake pedals down.

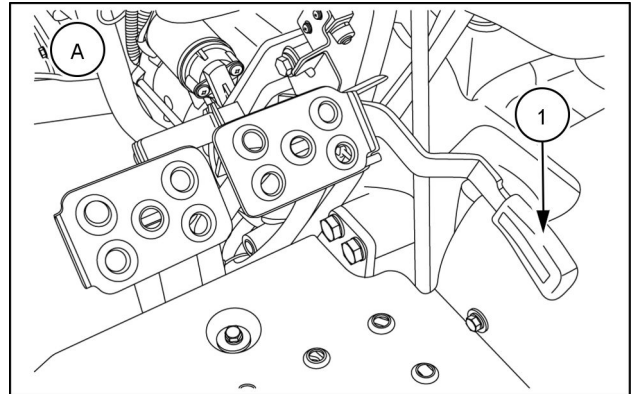

NHIL12CT00691AA 1

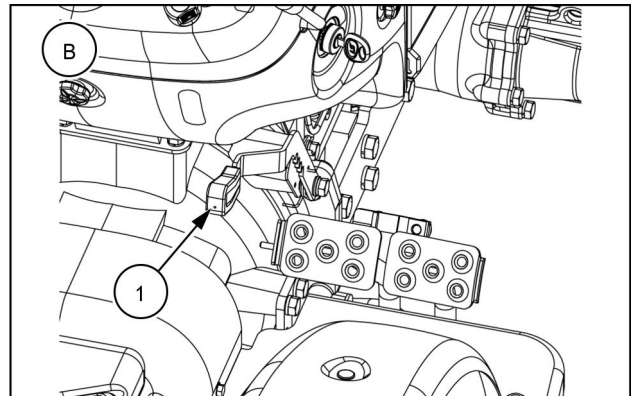

NHIL12CT00775AA 2

Four-Wheel Drive(4WD) lever

The four wheel drive (4WD) is controlled by a lever. The lever is located on the left-hand control pod.

NOTE: Use four wheel drive when additional traction is required while operating on loose soil, in wet, slippery conditions, or on slopes. For normal operation on firm soil, level hard surfaces, or when operating the unit at high speeds, disengage the four wheel drive to maximize tire and driveline life and to economize on fuel.

Mechanical model

To engage the four wheel drive on mechanical model tractors, stop the tractor completely, depress the clutch pedal and move the lever (1) completely forward. To disengage the four wheel drive, stop the tractor completely, depress the clutch pedal and pull the lever (1) rearward.

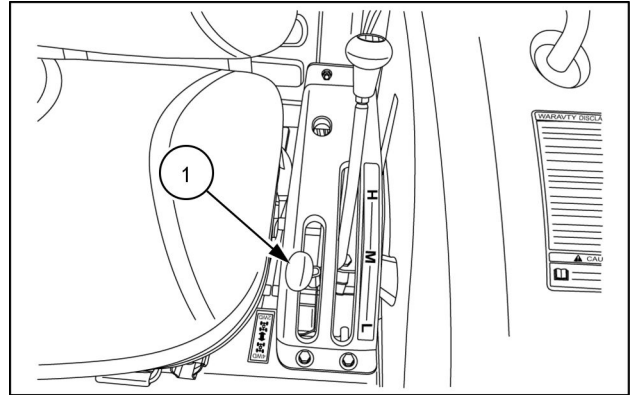

NHIL12CT00885AA 1

HST model

To engage the four wheel drive on HST model tractors, stop the tractor completely and move the lever (1) completely forward. To disengage the four wheel drive, stop the tractor completely and pull the lever (1) rearward.

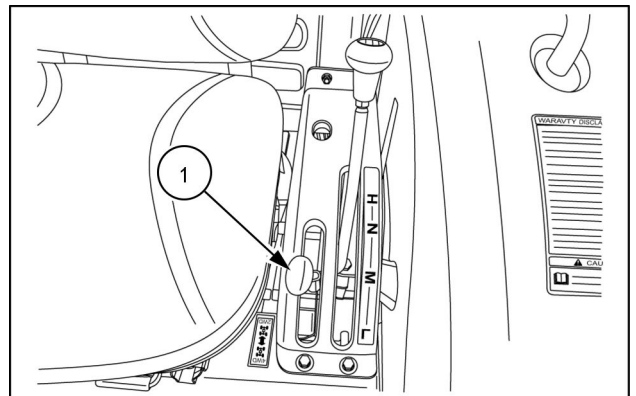

NHIL12CT00680AA 2

Mid Power Take-Off (PTO) (optional)

The mid PTO lever (1) is located on the left-hand control pod.

NOTE: The mid PTO is optional equipment on HST and mechanical model tractors.

To engage the mid PTO, pull up on the mid PTO lever, push down on the PTO switch and turn the switch to the "ON" position.

NOTE: When the mid PTO is engaged the rear PTO will also be engaged. The mid PTO cannot be engaged separately.

To disengage the mid PTO, push down on the PTO switch and push the mid PTO lever down to the "OFF" position.

NOTE: To start the engine the mid PTO lever must be in the down (disengaged) position and the PTO switch in the "OFF" position.

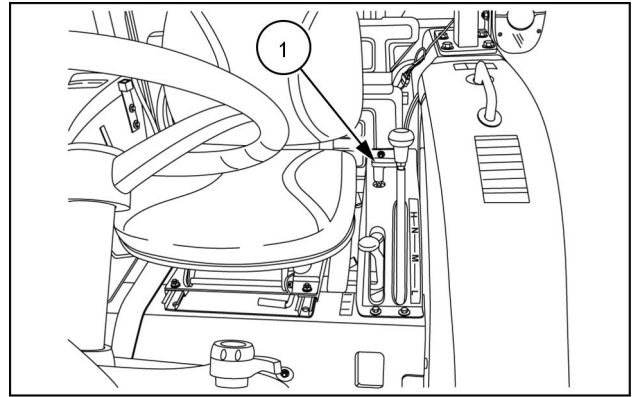

NHIL12CT00772AA 1

Right-hand side controls

Hydraulic Power Lift (HPL)

The Hydraulic Power Lift (HPL) lever (1) is located on the right-hand control pod. The lever controls the position of the two lift arms.

⚠ DANGER

Crushing hazard!

Make sure area is clear of all persons before lowering equipment.

Failure to comply will result in death or serious injury.

D0016A

To lower the lift arms, first make sure the drop rate control valve (2) is open, then move the HPL lever forward. To raise the lift arms, move the lever rearward. An adjustable lower stop (3) is located in this quadrant for returning the lever to a preset lowering position of the hitch. An adjustable upper HPL control lever height stop (4) prevents the control lever from exceeding the lift limit and causing the tractor hydraulic system to go over the relief valve setting.

The hydraulic lift system provides accurate, smooth, and instant hydraulic power for raising a variety of compatible equipment whenever the engine is running. The system's position control feature maintains the selected height or depth of three-point linkage equipment in relation to the tractor. When the hydraulic lift control lever is moved to a higher or lower setting in the quadrant, the system repositions the equipment to a higher or lower position and maintains the selected position.

Position control

Position control provides easy, accurate control of the three-point linkage equipment which operated above the ground, such as sprayers, rakes, mowers etc. It also provides uniform depth when using a blade or similar equipment on ground level.

When operating in position control, there is a definite relationship between the position of the control lever in the quadrant and the position of the equipment. The lever must be moved to change the position of the equipment relative to the tractor. The system will automatically maintain the equipment in the selected position.

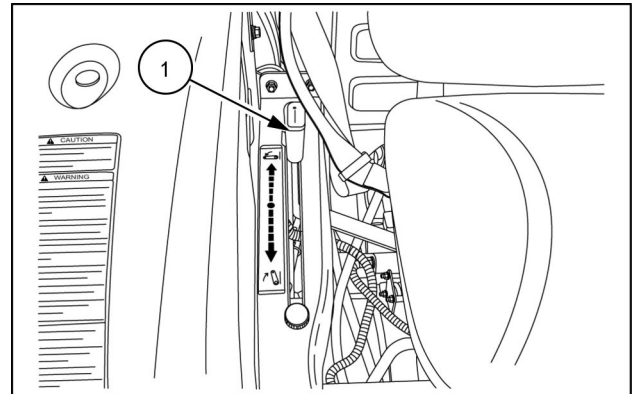

NHIL12CT00681AA 1

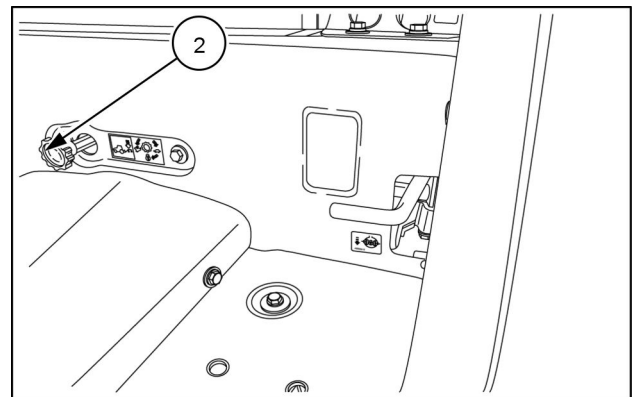

NHIL12CT00687AA 2

Rear remote control valve(s) - optional

⚠ WARNING

Escaping fluid!

Do not connect or disconnect hydraulic quick coupler under pressurized conditions. Make sure all hydraulic pressure is removed from the system before connecting or disconnecting hydraulic quick coupler.

Failure to comply could result in death or serious injury.

W0095B

Your tractor can be equipped with one or two optional rear remote hydraulic valves. The control lever(s) (1) and (2) is/are located right side of the seat.

NOTE: The rear remote hydraulic valves are optional equipment.

NOTE: Rear remote hydraulic valve kits are configured in either single spool or two spool. Once a single spool valve is installed, you CANNOT stack another single spool valve. You must purchase the two spool valve kit.

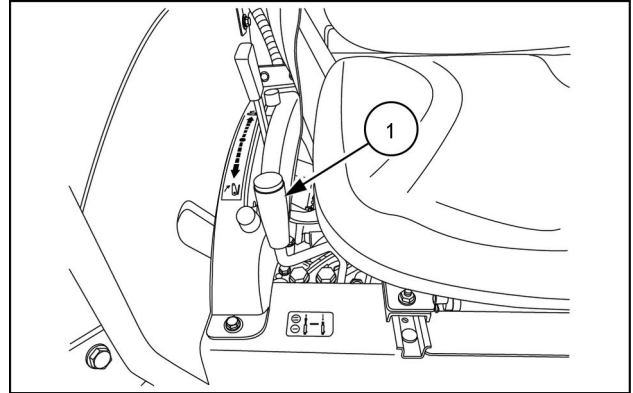

NHIL15CT00390AA 1

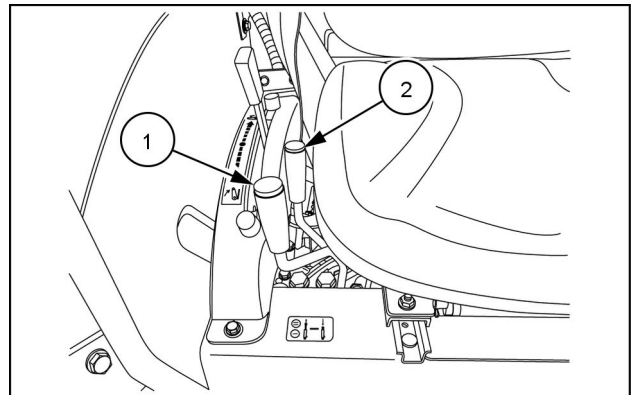

NHIL15CT00374AA 2

To operate the one spool valve, pull the selected control lever rearward to extend the cylinder and push the control lever forward to retract the cylinder. The #1 control lever (blue knob) is a detent type control valve. This valve will remain in the raise or lower position and will require the operator to manually return the control lever to the neutral position. This is useful in operating a hydraulic motor or a long stroke hydraulic cylinder. Return the control lever to neutral to stop the hydraulic motor or to hold the hydraulic cylinder in any position. This valve will not return to neutral once a hydraulic cylinder reaches the end of stroke. It is important to return the control lever to neutral when not using the control valve.

To operate the two spool valve, pull the selected control lever rearward to extend the cylinder and push the control lever forward to retract the cylinder. The #1 control lever (green knob) is a self-centering type control valve. Release the control lever to stop the cylinder in any position before it reaches full extension. The lever automatically returns to neutral. The #2 control lever (blue knob) is a detent type control valve. This valve will remain in the raise or lower position and will require the operator to manually return the control lever to the neutral position. This is useful in operating a hydraulic motor or a long stroke hydraulic cylinder. Return the control lever to neutral to stop the hydraulic motor or to hold the hydraulic cylinder in any position. This valve will not return to neutral once a hydraulic cylinder reaches the end of stroke. It is important to return the control lever to neutral when not using the control valve.

3 - CONTROLS AND INSTRUMENTS

The #1 (blue) set of couplers (**3**) is located inboard and the #2 (green) set of couplers (**4**) is located outboard. The rear remote valves come standard with **12.7 mm (0.5 in)** female quick couplers .

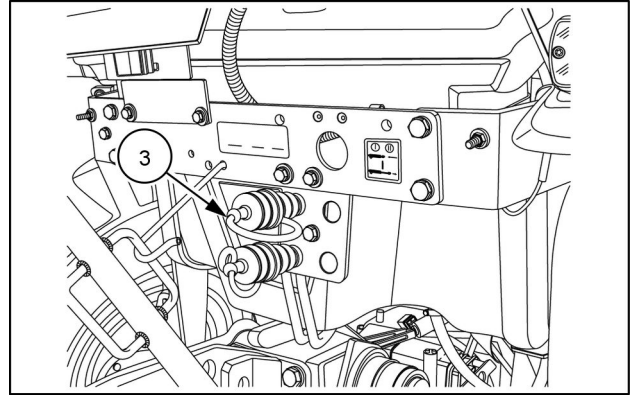

NHIL15CT00392AA 3

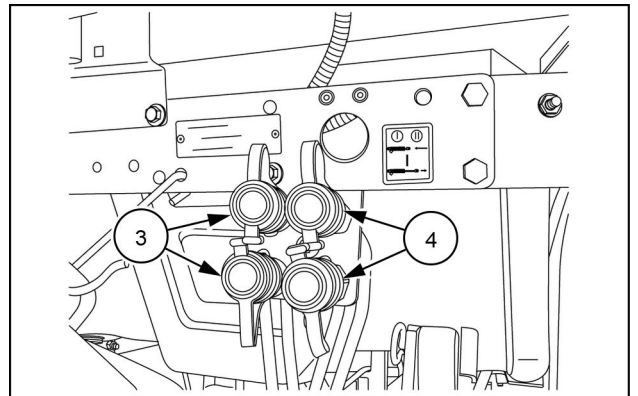

NHIL15CT00373AA 4

Mid-mount control valve

The mid mount two spool control valve **(1)** is mounted to the front of the right-hand fender. This control valve is used mainly for front end loader operation, but may also be used to operate other front mounted implements.

The control valve is equipped with a linkage lockout **(2)** that locks the control valve handle in the neutral position and does not allow the valve to operate.

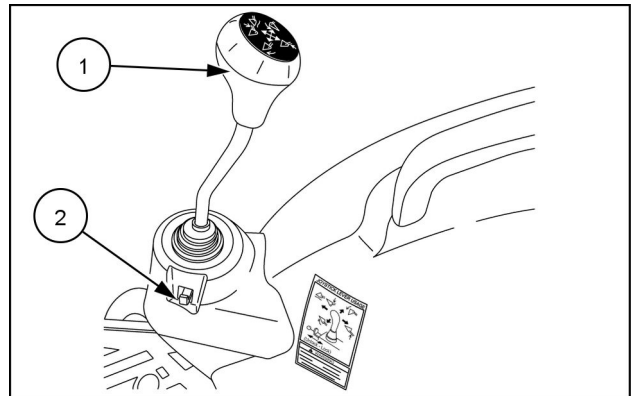

NHIL13CT01193AA 1

To operate the control valve, move the control lever **(1)** in any of the four directions.

Release the control lever to stop the cylinder in any position, the lever automatically returns to neutral.

- Move the control lever forward to lower the loader/retract cylinder **(A)**.
- Move the control lever to the left to curl the bucket/retract cylinder **(B)**.
- Move the control lever rearward to raise the loader/extend cylinder **(C)**.
- Move the control lever to the right to dump bucket/extend cylinder **(D)**.
- Move the control lever fully forward to "FLOAT" position **(E)** which allows the loader boom lift cylinders to extend or retract freely. This valve position will allow the loader to follow the ground contour during operation.

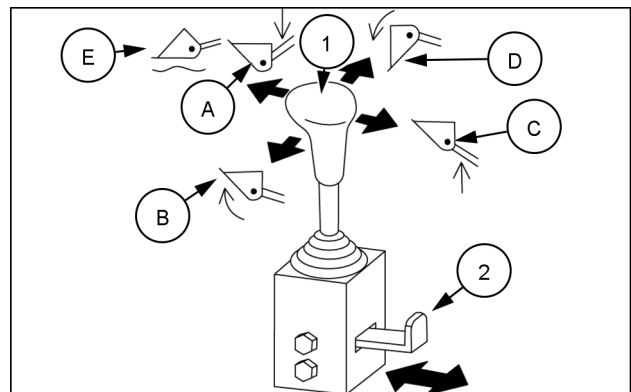

93100858 2

NOTE: Do not use the "FLOAT" position **(E)** if the loader bucket is raised off the ground. .

NOTE: Push the lockout tab **(2)** inwards to lock the valve control lever when the two-spool control valve is not used.

NOTE: If you move the control lever diagonally the loader and bucket will operate at the same time.

Hydraulic hose connection

⚠ WARNING

Crushing hazard!

Before disconnecting the cylinders or equipment, make sure you adequately support and secure the equipment or implement.

Failure to comply could result in death or serious injury.

W0243A

⚠ WARNING

Escaping fluid!

Remote couplers must be properly mounted and securely fastened to the machine mounting bracket for proper functioning of the safety disconnect feature.

Failure to comply could result in death or serious injury.

W0131A

When connecting hydraulic hoses, follow the instructions listed below.

- Loader down/retract cylinder, yellow coupler **(1)**.
- Loader up/extend cylinder, green coupler **(2)**.
- Bucket curl/retract cylinder, red coupler **(3)**.
- Bucket dump/extend cylinder, blue coupler **(4)**.

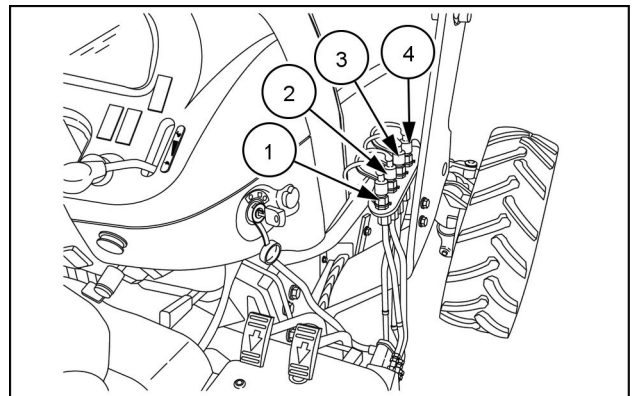

NHIL16CT02169AA 3

Mechanical transmission lever

Mechanical model

The transmission main gear shift lever (1) is located on the right-hand side of the operators platform, and is used to select any one of the four forward or reverse gears.

NOTE: With the combination of the shuttle shift, main shift, and range selector lever offer the operator a combination of twelve forward and twelve reverse gears.

The main gear shift lever must be operated only AFTER the tractor has stopped completely. Shift the main gear shift lever by designated "H" pattern. If the main gear shift lever is operated when the tractor is in motion, damage to the transmission gears could occur.

NOTE: The shift pattern is shown as sitting in the operators seat.

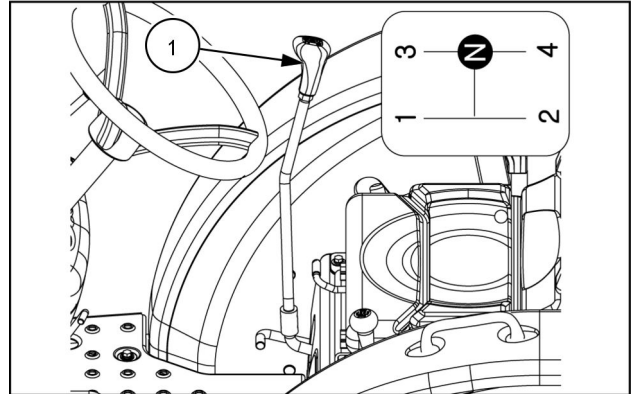

NHIL12CT00776AA 1

Exterior controls

Hood release latch

The latch release button is located on the left-hand side of the tractor hood.

1. To raise the hood, push the latch release button **(1)** inward and lift the hood to its fully raised position. A gas shock holds the hood in the fully raised position.
2. To close, lower the hood until it is retained by the latch mechanism.

NOTE: Keep latch mechanism free of dirt and debris so latch assembly will operate properly.

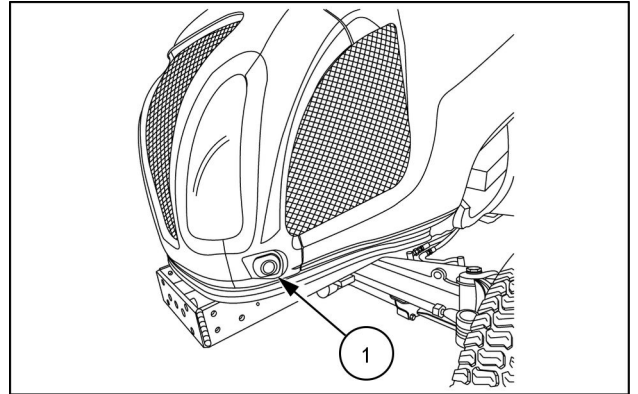

NHIL13CT01012AA 1

4 - OPERATING INSTRUCTIONS

Commissioning the unit

Engine break-in procedure

Your tractor will provide long and dependable service if given proper care during the first 50-hour break-in period. During the first 50 hours of operation:

1. Avoid "lugging" the engine. Operating in too high a gear under heavy load may cause engine lugging, which is indicated when the engine will not respond to a throttle increase.
2. Use the lower gear ratios when pulling heavy loads and avoid continuous operation at constant engine speeds. You will save fuel and minimize engine wear by selecting the correct gear ratio for a particular operation. Operating the tractor in low gear with a light load and high engine speed wastes fuel.
3. Avoid prolonged operation at either high or low engine speeds without a load on the engine.
4. Check the instruments frequently and keep the radiator and oil reservoirs filled to recommended levels. Daily checks include the engine oil level, radiator coolant, and air cleaner.
5. After the first 50 hours of use, be sure to perform the maintenance items listed in the maintenance schedule.

Diesel Particulate Filter (DPF) regeneration

⚠ WARNING

Fire hazard!

During the Diesel Particulate Filter (DPF) forced regeneration process the exhaust stack and fixed hood area becomes extremely hot. Park the machine outside and away from combustible or highly flammable material.

Failure to comply could result in death or serious injury.

W1165B

⚠ CAUTION

Burn hazard!

During the Diesel Particulate Filter (DPF) regeneration process the exhaust stack and fixed hood area becomes extremely hot. Allow area to cool before servicing or working near the exhaust system components.

Failure to comply could result in minor or moderate injury.

C0102B

Definitions of system components and operations

The following terms will define the system components and operational modes.

- Diesel Oxidation Catalyst (DOC) - Is a catalytic converter that reduces emission element such as hydrocarbons, carbon monoxide, and unburned fuel.
- Diesel Particulate Filter (DPF) - Is a filter that captures soot from the engine exhaust.
- (DPF) switch - Switch located on the left-hand side of the dash. This switch stops or blocks the regeneration process or to exit the inhibited regeneration mode. The switch can also initiate a forced regeneration.
- Regeneration - This is the process of burning/cleaning the soot that accumulates in the (DPF).
- Inhibited Regeneration - The regeneration process is disabled by the use of the (DPF) switch
- Forced Regeneration - The regeneration process is initiated by the use of the (DPF) switch

Diesel Oxidation Catalyst (DOC) and Diesel Particulate Filter (DPF)

The Diesel Oxidation Catalyst (DOC) and the Diesel Particulate Filter (DPF) function are to reduce engine exhaust hydrocarbons, carbon monoxide, and other toxic gases. This system converts exhaust emissions to harmless carbon dioxide and water. The (DPF) also traps Particular Matter (PM)

To meet Tier 4B (final) emission regulations, your tractor is equipped with a Diesel Oxidation Catalyst and a Diesel Particulate Filter (1). These components are located under the engine hood of the tractor.

It is very important to read this operator's manual and understand the safe operation of your tractor. If you have any questions in the operation of this emission system please contact your NEW HOLLAND dealer

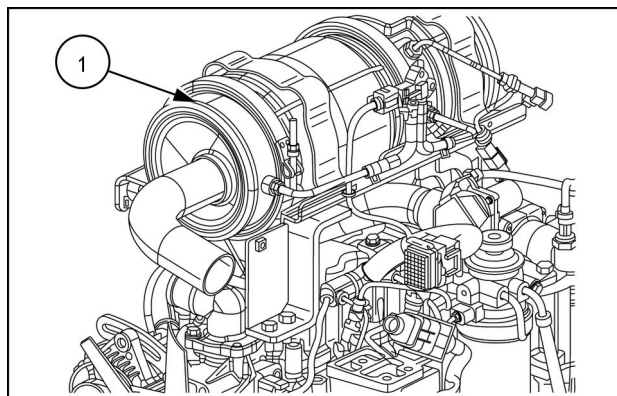

NHIL16CT00468AA 1

Fuel and engine lubrication oil specifications

Fuel specification

- Use only Ultra Low Sulfur diesel fuel (S15) in your tractor.

NOTICE: Use of diesel fuel other than Ultra Low Sulfur fuel may adversely affect the engine and the (DPF) performance.

Engine oil specification

- Use only (DPF) compatible (CJ-4) oil in your tractor engine.

NOTICE: Use of any engine oil other than (CJ-4) may clog the (DPF) earlier than expected and fuel usage may increase.

Auto regeneration mode operation

⚠ WARNING

Fire hazard!

During the Diesel Particulate Filter (DPF) forced regeneration process the exhaust stack and fixed hood area becomes extremely hot. Park the machine outside and away from combustible or highly flammable material.

Failure to comply could result in death or serious injury.

W1165B

In this operational mode, the operator does not have to take any actions; the engine electronic controller activates the system automatically.

The following conditions will activate the regeneration cycle:

- Soot load of (DPF) is 100% of capacity.
- Engine exhaust temperature reaches designated regeneration temperature.
- (DPF) inhibited indicator light is “OFF.”

NOTE: Duration of regeneration operation is approximately 15 to 25 minutes. During the regeneration, it is normal to have a smell of burning or overheating.

During the regeneration operation, the (DPF) regeneration indicator light (1) and (DPF) temperature indicator light (2) will both illuminate.

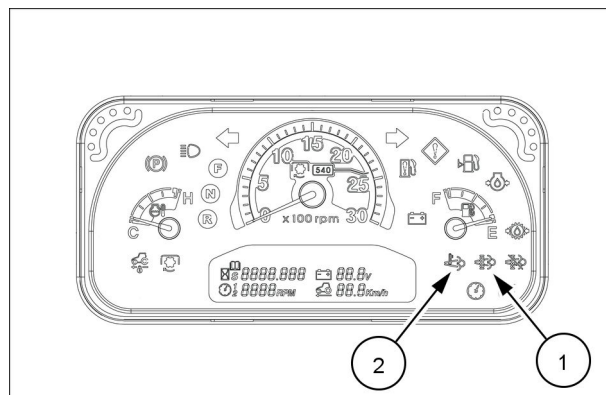

NHIL16CT00387FA 2

NOTICE: Do not switch the key switch to the “OFF” position during regeneration mode. Soot in the (DPF) will not be completely burned and may increase fuel consumption. The operator must operate regeneration mode until all indicator lights are “OFF” with the key switch in the “ON” position. In case of turning off the engine during regeneration mode, the regeneration mode will resume when restarting the engine

Inhibited regeneration mode operation

NOTICE: Blocking or stopping regeneration is done when a condition that may risk a fire hazard due to high exhaust temperatures during regeneration occurs.

Activating the (DPF) switch (3) that is located on the left-hand side of the dash, can delay or stop the regeneration mode.

To set the inhibited regeneration mode:

1. Press the lower side (A) of the (DPF) switch (3) for approximately two seconds.
2. When inhibited mode is activated the (DPF) inhibited indicator light (4) will be illuminated.

NOTICE: When tractor arrives at a safe regeneration location, press the upper side (B) of the (DPF) switch for approximately two seconds to return the regeneration system to the auto regeneration mode. If regeneration system is not automatic, excessive soot in the (DPF) may overload the emission system and result in a reduction of engine power or damage to the regeneration system.

NOTICE: If, when notified by the instrument panel (DPF) indicator lights that a regeneration of the (DPF) is due, and the operator does not proceed with a regeneration of the (DPF), the functionality of the (DPF) will be impaired. If the operator continues to ignore or interrupt the regeneration notification, this will damage the (DPF) to such an extent as to require the (DPF) to be replaced by an authorized NEW HOLLAND dealer.

To exit the inhibited regeneration mode:

1. Press the upper side (B) of the (DPF) switch (3) for approximately two seconds.
2. When inhibited mode has been exited the (DPF) inhibited indicator light (4) will not be illuminated.

NOTE: If the operator shuts off the tractor during the inhibited mode, when restarting the tractor, the regeneration system will return to the auto regeneration mode.

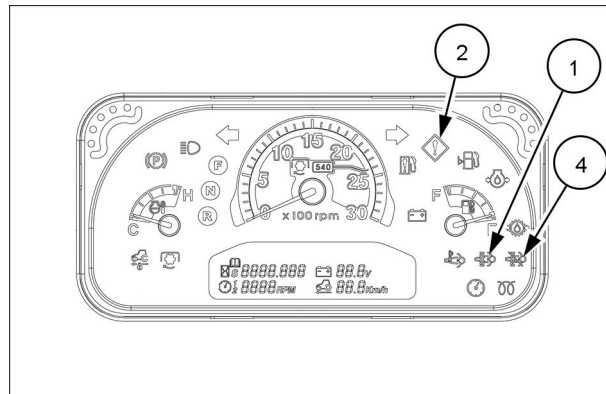

NHIL16CT00387FA 3

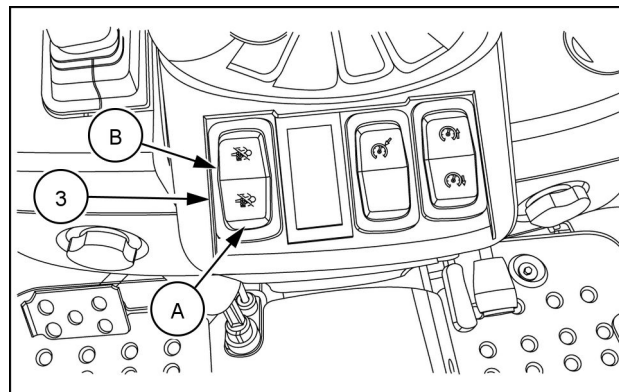

NHIL17CT00213AA 4

Forced regeneration mode operation

⚠ WARNING

Fire hazard!

During the Diesel Particulate Filter (DPF) forced regeneration process the exhaust stack and fixed hood area becomes extremely hot. Park the machine outside and away from combustible or highly flammable material.

Failure to comply could result in death or serious injury.

W1165B

It is possible to perform a forced regeneration of the (DPF) before an automatic regeneration is requested. To be able to perform a forced regeneration it will be necessary to stop work for the entire duration of the procedure which is approximately 15 to 25 minutes.

The following conditions must also be met for a forced regeneration to occur.

- shift the transmission to neutral
- apply the parking brake
- throttle at the low idle position

NOTE: Should the above conditions change during the entire process of forced regeneration the operation will stop.

Proceed as follows to start a forced regeneration

1. Press the upper side **(B)** of the (DPF) switch **(3)** for approximately three seconds.

During the forced regeneration operation, the (DPF) regeneration indicator light **(1)** and (DPF) temperature indicator light **(2)** will both illuminate.

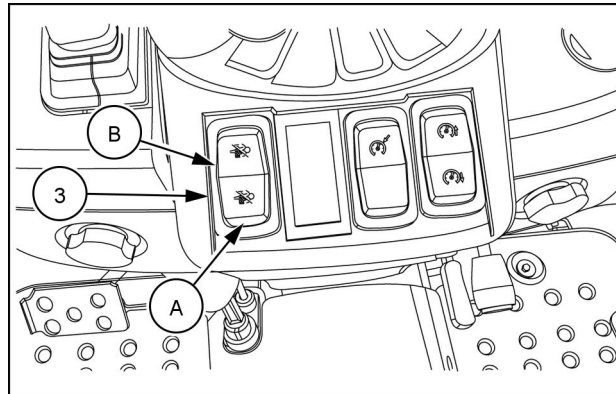

NHIL17CT00213AA 5

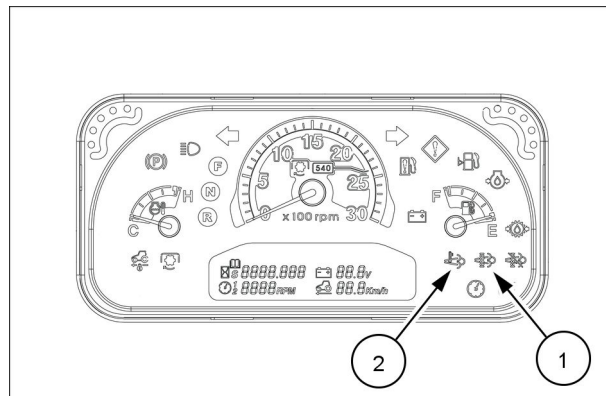

NHIL16CT00387FA 6

The engine warning (1) (DPF) Temperature (4) (DPF) Re-generation (3) and (DPF) Inhibitor (2) have several different operating definitions. Read the table below and be aware of the definitions for each occurrence.

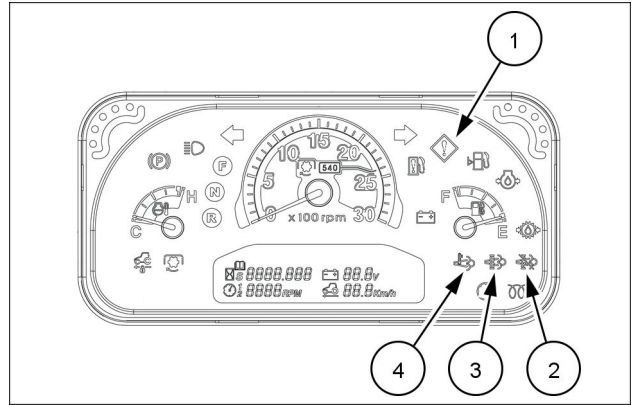

NHIL16CT00387FA 7

Combination of (DPF) indicator lights on the instrument panel					
Engine Warning	Indicator symbol			(DPF) Regeneration Mode	(DPF) Status and definition
	(DPF) Temperature	(DPF) Re-generation	(DPF) Inhibitor		
OFF	ON	ON	OFF	Auto-regeneration operation mode	The soot load in the (DPF) has reached 100% and the (DPF) is regenerating automatically Normal state of operation.
OFF	OFF	Blink (1sec)	OFF	(DPF) requires regeneration	The soot load in the (DPF) is over 120%. Press and hold the upper side of the (DPF) switch over three seconds for regeneration.
ON	OFF	Blink (0.5sec)	OFF	Power limit operation mode	The soot load in the (DPF) is over 150%. Contact your NEW HOLLAND for assistance.
OFF	OFF	OFF	ON	(DPF) inhibited operation mode	Press the upper side of the (DPF) switch for two seconds to allow regeneration after entering a safe area.

Engine speed management

The Engine Speed Management (ESM) function allows the operator to select and save a specific engine speed and return to that speed with the push of a single button.

The ESM main switch **(1)** controls the Engine Speed Management (ESM) function.

- Position **(C)** Enable/Save (momentary position)
- Position **(B)** On
- Position **(A)** Off

Moving the ESM main switch from position **(A)** to position **(B)** will cause:

- The ESM indicator **(3)** on the instrument panel will blink.
- The engine speed **(4)** stored in the ECU to display on the LCD panel.

Depressing the ESM main switch from position **(B)** to position **(C)** will cause:

- Momentarily depress the ESM main switch to enable and recall the last saved engine speed. The ESM indicator **(3)** will change to solid.

NOTE: The park brake must be released and the brakes cannot be depressed for the ESM to activate.

- Depress and hold the ESM main switch for **2 s** in the position **(C)** to save the current engine speed into the memory for recall. The stored engine speed **(4)** will blink three times on the LCD panel.

The ESM up/down switch **(2)**, is used to adjust the engine speed for ESM when the ESM is enabled.

Depress the upper or lower side of the ESM up/down switch to adjust engine speed.

- Depress the front side to increase speed.
- Depress the rear side decrease speed.

NOTE: A momentary depress of the switch will increase or decrease the engine speed by approximately **10 RPM**. Maintaining pressure on the switch will permit the speed to ramp up or down at approximately **25 RPM/second**, providing there is no load on the engine.

To exit the ESM control:

- Depress the ESM main switch to the OFF position **(A)** or depress the brake pedals.

NOTE: If the hand or foot throttle are moved above the ESM saved engine speed, the engine speed will increase to the setting of the hand or foot throttle. The ECU will pick the highest engine speed input from the ESM saved engine speed, hand throttle, and foot throttle.

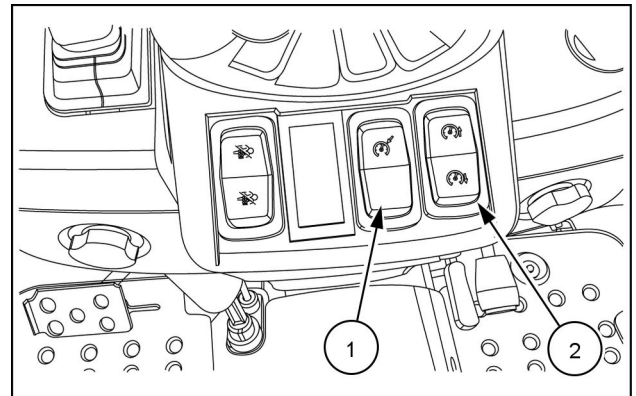

NHIL17CT00213AA 1

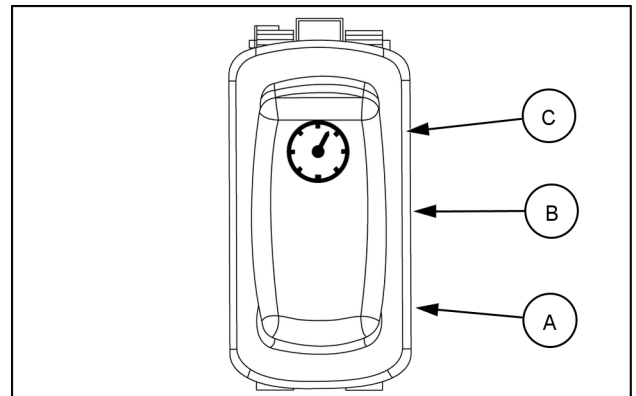

NHIL16CT00424AA 2

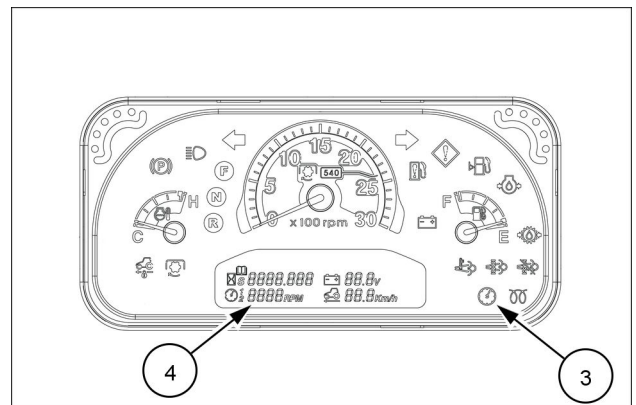

NHIL16CT00387FA 3

Power Take-Off (PTO) operation

Rear PTO

1. To engage the Power Take-Off (PTO), push the PTO switch (1) down and turn the switch to the "ON" position (2).
2. The PTO system is totally independent of the tractor ground speed, and the following operations can be performed.
 - The tractor ground travel can be stopped without stopping the PTO.
 - Stop the PTO by disengaging the PTO clutch without stopping the tractor ground travel.
3. To disengage the PTO, push down on the PTO switch and the switch will automatically return to the "OFF" position (3).

NOTE: When the PTO is engaged the PTO indicator light (A) will be illuminated on the instrument panel.

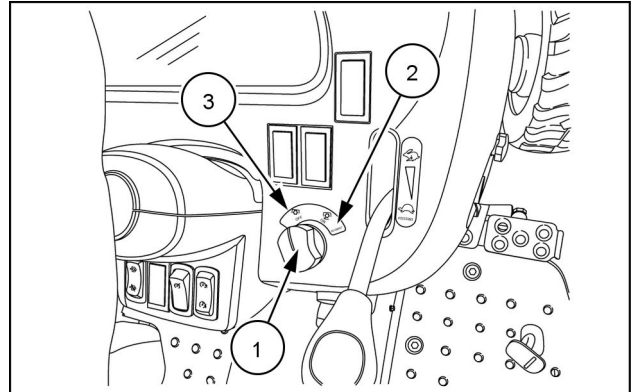

NHIL17CT00211AA 1

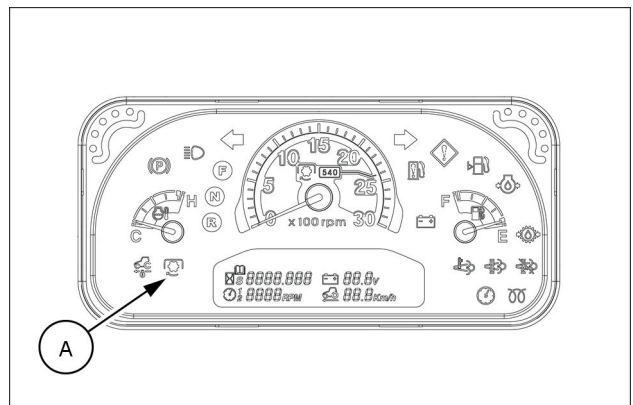

NHIL16CT00387FA 2

Mid PTO (Optional)

1. To engage the mid PTO, pull up on the mid PTO lever (1) push down on the PTO switch and turn the switch to the "ON" position.
- NOTE:** When the mid PTO is engaged the rear PTO will also be engaged. The mid PTO cannot be engaged separately.
2. To disengage the mid PTO, push the mid PTO lever (1) down to the "OFF" position and , push down on the PTO switch and the switch will automatically return to the "OFF" position.

NOTE: To start the engine the mid PTO lever must be in the down (disengaged) position and the PTO switch in the "OFF" position.

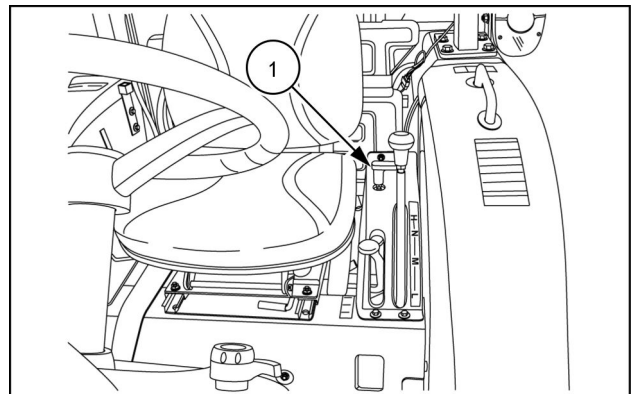

NHIL12CT00772AA 3

Rear PTO operation without operator present

⚠ WARNING

Entanglement hazard!

Before operating stationary Power Take-Off (PTO) equipment, do the following: apply the parking brake, place all controls in the neutral position, and block all four wheels.

Failure to comply could result in death or serious injury.

W0336A

NOTICE: *The engine will shut off in approximately two seconds if the operator leaves the seat without the main transmissions shift lever/shuttle shift lever in the neutral position, HST pedals not in the neutral position or the Mid PTO lever not in the "OFF" position.*

NOTE: *The Mid PTO cannot be operated without an operator present in the seat.*

To operate the rear PTO without the operator in the seat the following operations must be performed:

- Main transmission shift/Shuttle shift lever in NEUTRAL position.
- Park brake engaged.
- Mid PTO in "OFF" position (if equipped).
- Rear PTO in "ON" position.

NOTE: *The alarm will sound when the following conditions are present:*

- Rear PTO is engaged.
- Operator not in the seat.
- Park brake disengaged.

Three-point hitch

The tractor's three-point linkage is used to attach three-point mounted equipment which is usually PTO operated, such as rotary mowers, tillers, flail mowers, snowblowers, etc. The three linkage points are the two lower lift arms and the top link.

The three-point linkage has easy to adjust sway bars **(1)** to control lateral movement of the lift arms. The length of the top link **(2)** and the height of the left-hand and right-hand lift arms **(3)** and **(4)** can be adjusted to ease the attachment of implements and to level the implement after attaching.

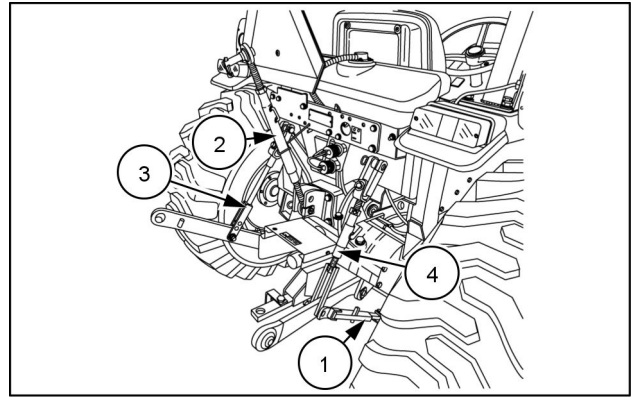

NHIL12CT00803AA 1

Attaching three-point equipment

⚠ WARNING

Entanglement hazard!

Before attaching or detaching equipment or changing the Power Take-Off (PTO) shaft: 1) Apply the parking brake. 2) Move all controls to neutral and PTO control knob to the disengaged position. 3) Stop the engine and remove the key. 4) Wait for the PTO shaft to stop turning before leaving the cab. Failure to comply could result in death or serious injury.

W0323A

NOTICE: *When attaching mounted or semi mounted implement to the three-point linkage, ensure that there is adequate clearance between the implement and the rear of the tractor. The clearances in the raised position should be checked by raising the implement carefully with the position control lever. With the implement fully raised there must be at least **100 mm (4 in)**. Clearance between the implement and the nearest part of the tractor.*

Most implements can be attached to the tractor as follows:

1. Position the tractor so that the lower link hitch points are level with and slightly ahead of the implement hitch pins. Carefully bring the tractor rearwards to match the tractor and implement hitch points. First attach the left-hand lower link, then by adjusting the leveling box, attach the right lower link.
2. Lengthen or shorten the top link until the implement mast pin can be inserted through the mast and upper link of the implement.
3. When detaching the implement, the procedure is the reverse of attaching. The following hints will make detaching easier and safer.
 - Always park the implement on a level, firm surface.
 - Implement should be supported so that it cannot tip or fall when detached from the tractor.
 - Always relieve all hydraulic pressure in any remote cylinders before detaching.

Left-hand lift rod adjustment

⚠ WARNING

Crushing hazard!

Before disconnecting a lift rod from the lower link, lower the attached implement to the ground, and stop the engine. Make sure the attached implement is correctly supported and no pressure remains in the hydraulic system before removing the lift rod securing pins.

Failure to comply could result in death or serious injury.

W0034A

NOTICE: The left-hand lift rod (1) is adjustable but must be removed from the lift arm before length can be changed.

To lengthen or shorten the left-hand lift rod (1) remove the bolt and nut (2) from the lift rod and lower link (3). Rotate the top half of the lift rod clockwise to reduce the length and counter-clockwise to increase the length.

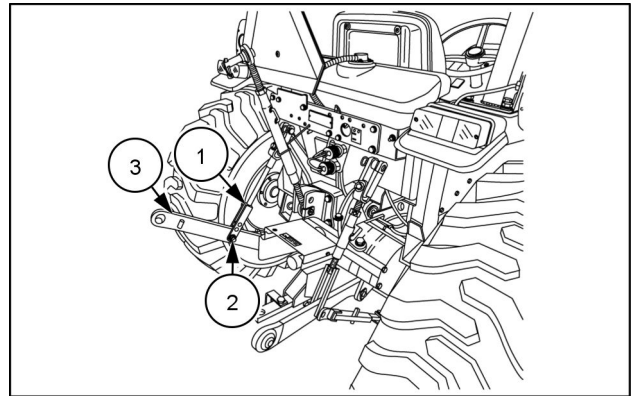

NHIL12CT00803AA 1

Right-hand lift rod adjustment

NOTICE: The right-hand lift rod is readily adjustable even when connected between the lift arm and lower link.

To lengthen or shorten the right-hand lift rod (1) loosen jam nut (2) and rotate lift rod clockwise to reduce the length and counter-clockwise to increase the length.

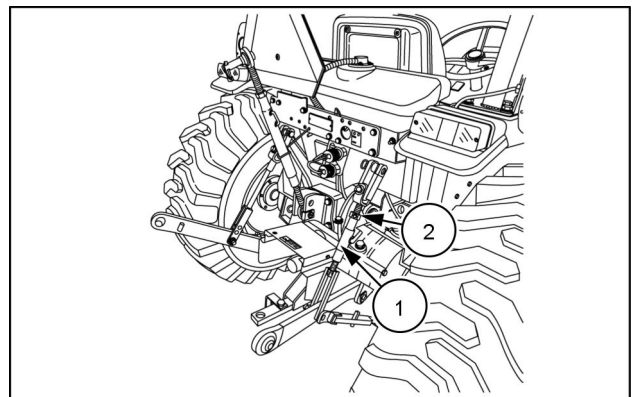

NHIL12CT00803AA 2

Top link adjustment

To adjust the top link length, loosen the jam nut (1). Hold the link end (2) and rotate the handle (3) on the sleeve to lengthen or shorten the top link. After adjustment tighten the jam nut to prevent unwanted rotation of sleeve when in use.

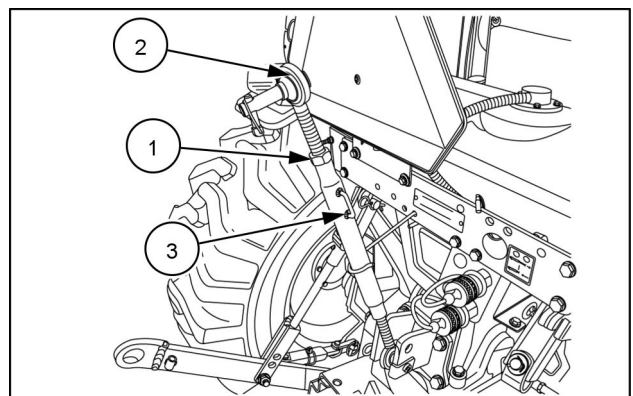

NHIL12CT00805AA 3

Telescoping stabilizers and optional flex end links adjustment

Telescoping stabilizers and fixed end links are standard equipment on the tractor, the flex end links are optional equipment.

The telescoping stabilizers (1) use a pin and multiple hole arrangement for easy adjustment, for side to side movement of the three-point linkage.

To adjust the stabilizer, pull the pin (2) and adjust the stabilizer and insert the pin into the desired hole.

NOTE: Cycle the three point linkage through the entire travel and check for interference with the rear tires. If interference is present, adjust stabilizers as needed.

⚠ WARNING

Machine damage can cause accidents!

Only operate three-point equipment with both flex ends returned to the latched position.

Failure to comply could result in death or serious injury.

W0467A

The (optional) flex ends (3) on the lower lift arms are adjusted by pushing down on the clamp (4) and sliding the ends to the desired length. Once the implement is attached, push in on the flex ends until the ends are in the latched position in the arms.

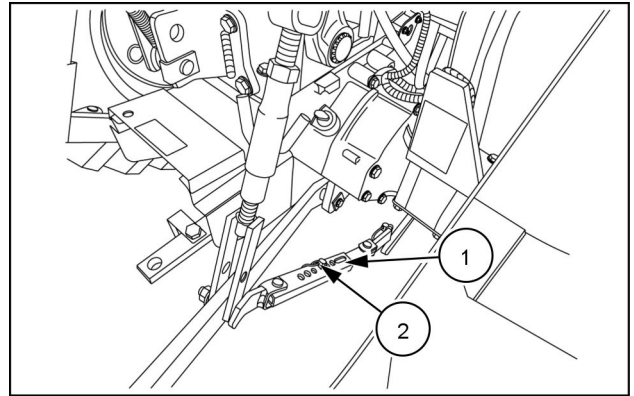

NHIL12CT00804AA 4

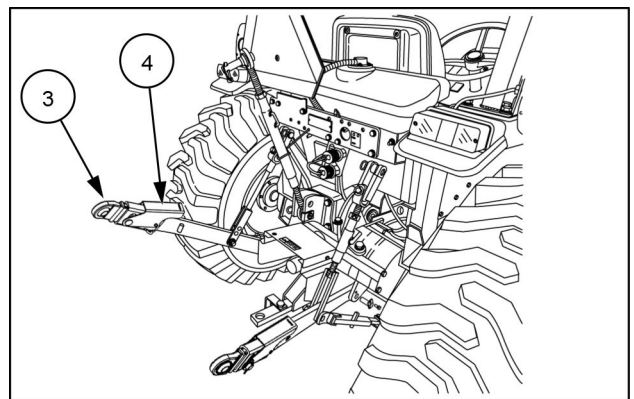

NHIL12CT00837AA 5

Drawbar - Operating

NOTICE: When transporting equipment on highways, a safety chain with a tensile strength equal to the gross weight of the implement should be installed between the tractor and implement hitch.

Your tractor is equipped with a fixed/extendible drawbar (1) for towing equipment behind the tractor.

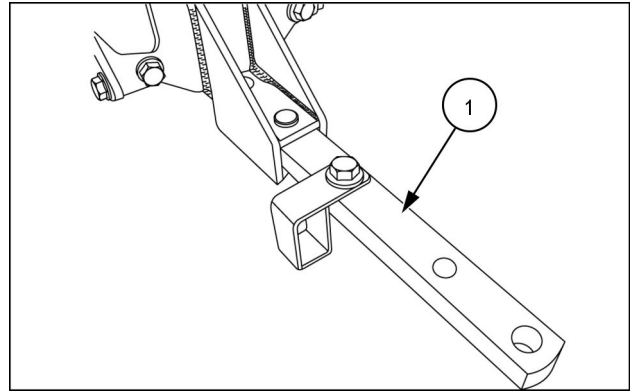

93100910 1

NOTICE: The drawbar is required to provide standard rear PTO drawbar relationship.

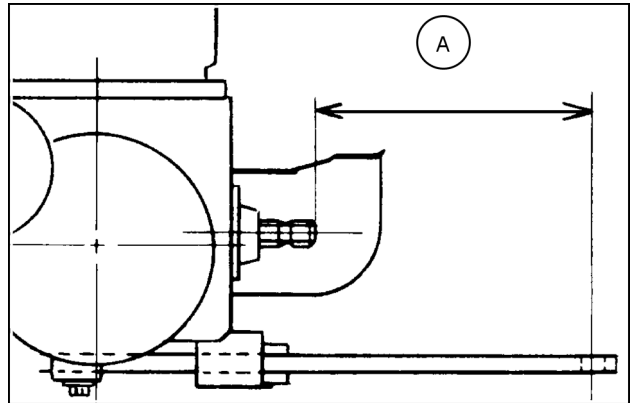

20099087 2

(A) 356 mm (14 in)

⚠ WARNING

Overturning hazard!
Always use the drawbar, pick-up hitch, or lower links in the lowered position for pull-type work. Do not pull from the lower links if they are above the horizontal position. Failure to comply could result in death or serious injury.

W0417A

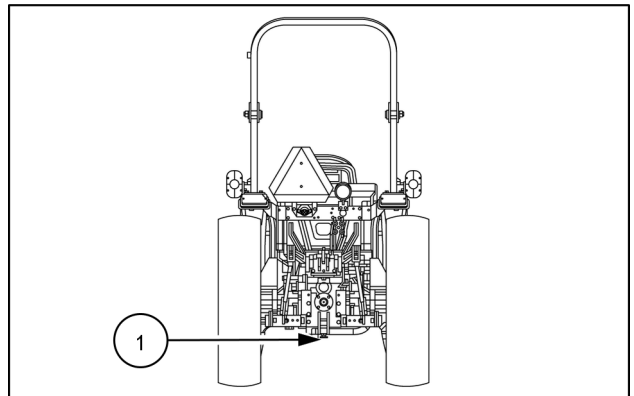

NHIL23CT00448AA 3

(1) Drawbar

Top link installation

The hydraulic lift rocker (1) has two holes for attaching the upper link. Attach the link using the lower hole for light draft loads, such as mowers. Attach the link to the top hole for heavier draft loads, such as ground engaging equipment.

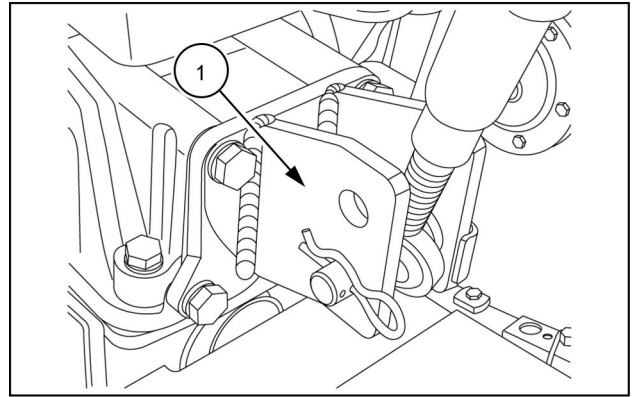

NHIL12CT00806AA 1

Drop rate control valve

The drop rate control valve **(1)** provides an adjustment to regulate the flow of oil from the lift cylinder. This allows the operator to slow or increase the rate of drop of the lower links.

Turn the drop rate control valve "IN" (clockwise) to decrease the rate of drop. Turn the valve "OUT" (counter-clockwise) to increase the rate of drop.

The drop rate control valve must be opened before the hydraulic lift control will lower. If the valve is turned all the way "IN" (clockwise), the lower links can be raised to maximum height but cannot be lowered.

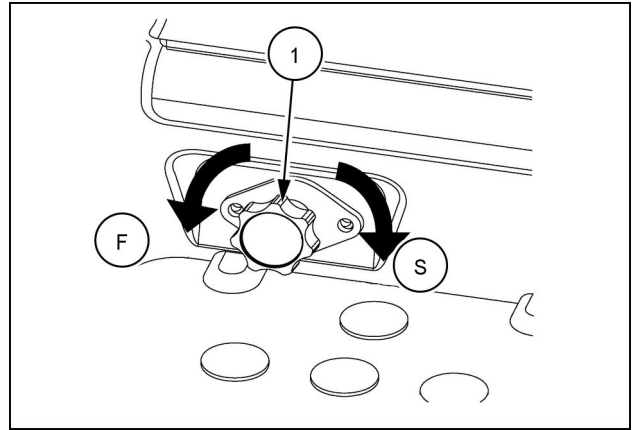

200900060A 1

NOTE: The drop rate control valve needs to be adjusted accordingly to the amount of weight being carried on the rear hitch arms.

(F) Fast
(S) Slow

Starting the unit

Key switch - Operating

The key switch (1) is located on the right-hand side of the rear hood panel.

The key switch has three positions.

- A. (STOP / OFF) This position will shut off the engine.
- B. (ON / RUN) This position activates the warning lights, instruments, and automatic engine preheat system
- C. (START) This position engages the engine starter. When key is released an internal spring returns the key to the ON / RUN position.

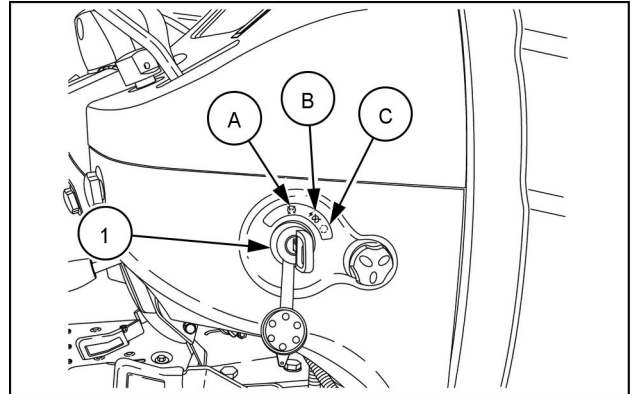

NHIL15CT00472AA 1

Glow plugs - Cold start aid

⚠ WARNING

Explosion hazard!

DO NOT use ether starting fluid. Serious engine damage, explosion, death, or serious personal injury could occur.

Failure to comply could result in death or serious injury.

W0148A

NOTICE: When starting the machine after long periods, avoid immediate use of hydraulics. It is necessary to allow time for enough lubrication of all moving parts before subjecting them to work loads, particularly if outdoor temperatures approach 0°C (32°F). Run the engine at 1300 to 1500 RPM for approximately fifteen minutes to bring the rear drive oil up to normal operating temperature. Failure to comply could seriously damage machine.

To preheat the engine, turn the key switch (1) to the middle ON / RUN position (A). The cold start indicator light (2) will illuminate from three to twelve seconds, depending on the ambient temperature. The glow plugs heat the precombustion chambers of the engine cylinder head during this time. After the indicator light goes off the tractor can be started.

NOTE: The preheat is auto-timed, when the indicator light goes off, the power to the glow plugs is also removed.

NOTE: A coolant immersion heater is available as a dealer installed option. This heater allows for easier starting in temperatures below -17.7 °C (0 °F) by warming the engine coolant.

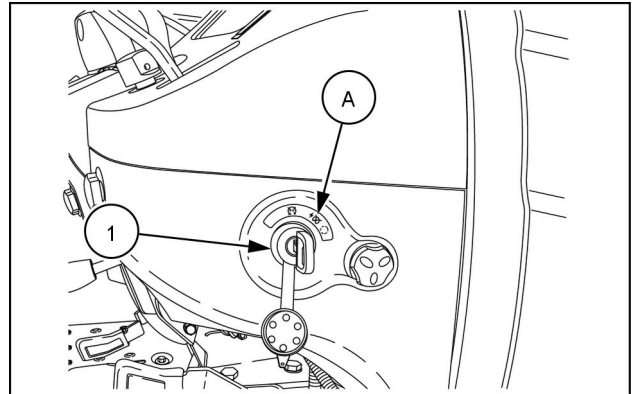

NHIL15CT00472AA 1

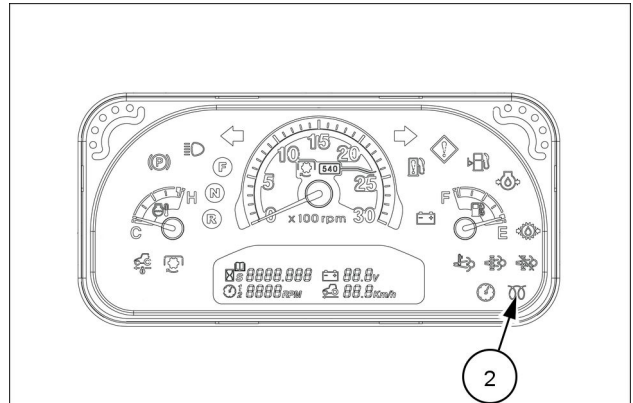

NHIL16CT00387FA 2

Starting the engine (Mechanical)

⚠ WARNING

Run-over hazard!

When attempting to start the engine, always sit in the operator's seat with the parking brake engaged and all control elements in neutral. Never attempt to start the engine while standing beside the machine.

Failure to comply could result in death or serious injury.

W0967B

The key switch (1) allows activation of the starter motor and fuel delivery only when:

- The transmission forward/reverse shuttle lever (2) is in the neutral position.
- The PTO switch (3) is in the "OFF" position.
- The mid PTO lever (4) is in the "OFF" position (if equipped).
- The clutch pedal (5) is depressed.

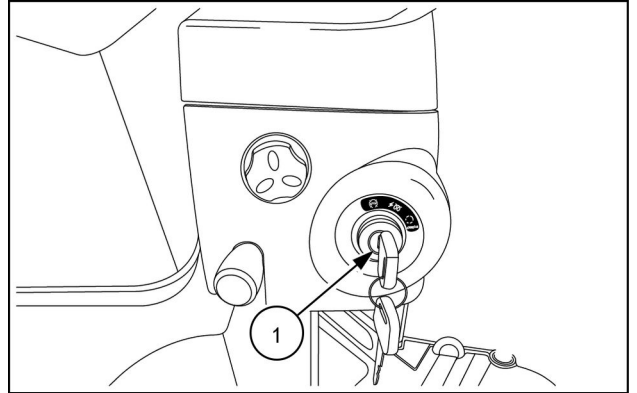

NHIL15CT00591AA 1

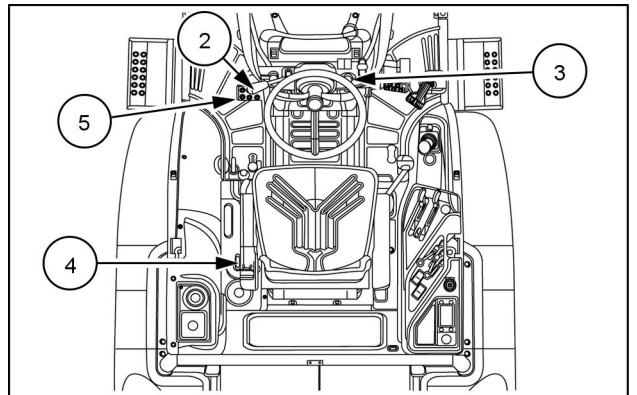

NHIL15CT00666AA 2

Starting procedure

NOTE: On startup, engine RPM's may adjust automatically by software loaded on the unit based on the ambient temperature. This process can take up to **60 s**.

1. Turn the key switch (1) to the middle "ON" position (A) and check if the cold start (3) engine oil pressure (4) and battery charge (5) indicator lights are illuminated.
2. Set the hand throttle lever (2) to the low idle position.
3. Wait until the cold start indicator light (3) goes off, approximately **3 to 12 s**, depending on ambient temperature.
4. Turn the key to the extreme right to the "START" position (B). As soon as the engine starts, release the key to allow it to return to the middle "ON" position.

NOTICE: Do not crank the engine continuously for more than **10 s**. Failure to comply may shorten life of starter motor.

5. If indicator lights engine oil pressure (4) and battery charge (5) are illuminated, shut off the engine immediately and refer to **8-1**.

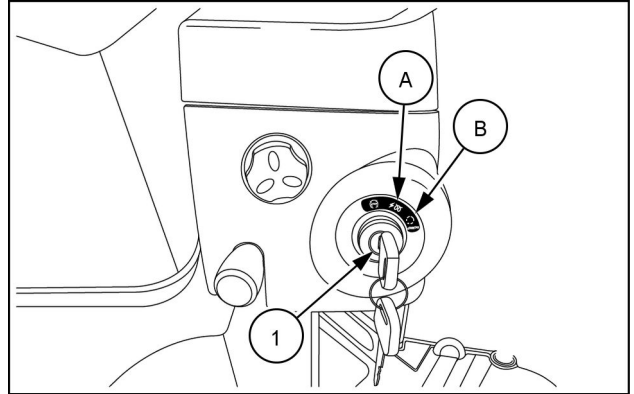

NHIL15CT00591AA 3

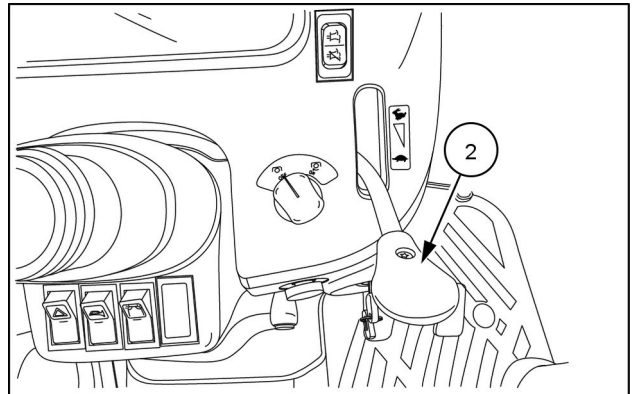

NHIL15CT00592AA 4

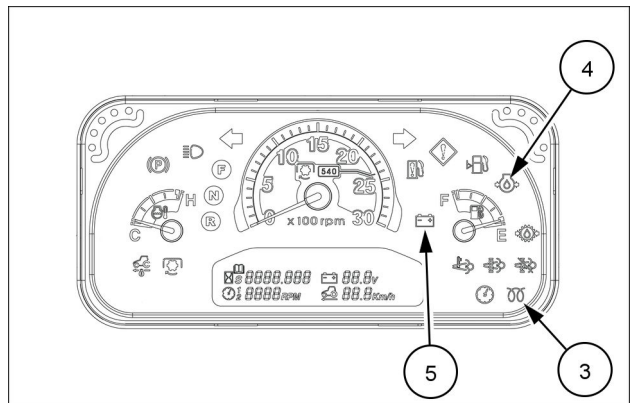

NHIL16CT00387FA 5

Operator presence system (start operation)

Operator	Rear PTO	Mid PTO	Transmission	Park Brake	Clutch Pedal	Condition
Out of Seat	Off	Off	Shuttle in Neutral	Engaged	Depressed	Start *
Out of Seat	Off	Off	Shuttle in Neutral	Disengaged	Depressed	Start with Alarm *
In Seat	Off	Off	Shuttle in Neutral	Engaged	Depressed	Start
In Seat	Off	Off	Shuttle in Neutral	Disengaged	Depressed	Start with Alarm
* It is not recommended to start the tractor when you are out of the operator's seat.						

NOTE: For starting, if Rear PTO or Mid PTO is engaged, tractor will not start.

Operator presence system (run operation)

NOTE: The following conditions are for when the engine is running and the operator gets out of the seat.

Rear PTO	Mid PTO	Transmission	Park Brake	Condition
Off	Off	Neutral	Disengaged	Alarm
On	Off	Neutral	Engaged	No Alarm
On	Off	Neutral	Disengaged	Alarm
Off	Off	In Gear	Either	Shutdown
On	Off	In Gear	Either	Shutdown
On	On	In Gear	Either	Shutdown
Off	On	Neutral	Either	Shutdown

Starting the engine (Hydrostatic transmission)

⚠ WARNING

Run-over hazard!

When attempting to start the engine, always sit in the operator's seat with the parking brake engaged and all control elements in neutral. Never attempt to start the engine while standing beside the machine.

Failure to comply could result in death or serious injury.

W0967B

The key switch (1) allows activation of the starter motor and fuel delivery only when:

- HST forward/reverse pedals (2) are in the neutral position
- PTO switch (3) is in the "OFF" position.
- Mid PTO lever (4) is in the "OFF" position (if equipped)

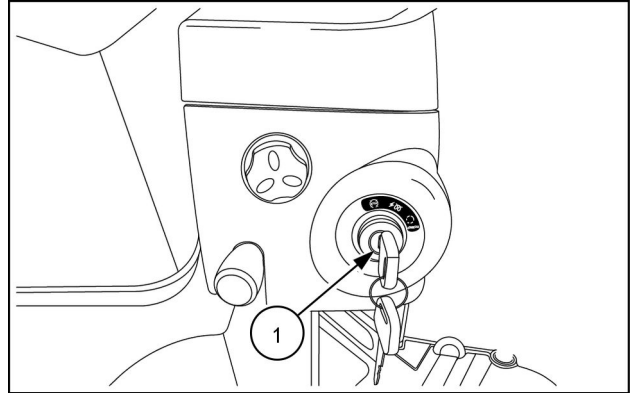

NHIL15CT00591AA 1

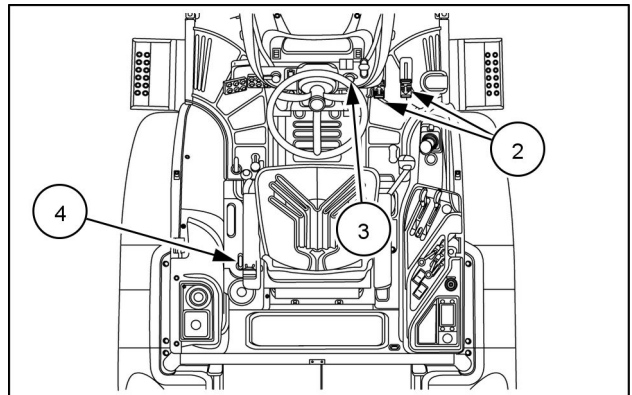

NHIL15CT00665AA 2

Starting procedure

NOTE: On startup, engine RPM's may adjust automatically by software loaded on the unit based on the ambient temperature. This process can take up to **60 s**.

1. Turn the key switch (1) to the middle "ON" position (A) and check if the cold start (3) engine oil pressure (4) and battery charge (5) indicator lights are illuminated.
2. Set the hand throttle lever (2) to the low idle position.
3. Wait until the cold start indicator light (3) goes off, approximately **3 to 12 s**, depending on ambient temperature.
4. Turn the key to the extreme right to the "START" position (B). As soon as the engine starts, release the key to allow it to return to the middle "ON" position.

NOTICE: Do not crank the engine continuously for more than **10 s**. Failure to comply may shorten life of starter motor.

5. If indicator lights engine oil pressure (4) and battery charge (5) are illuminated, shut off the engine immediately and refer to **8-1**.

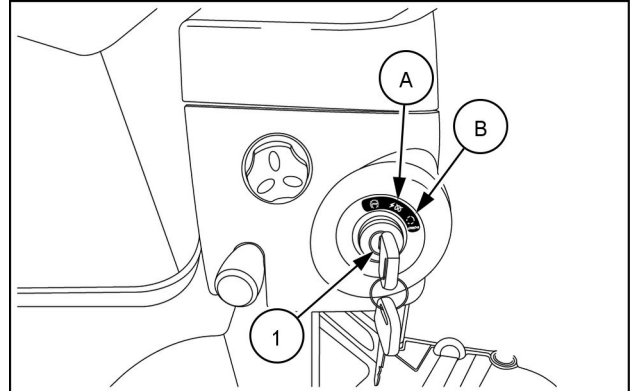

NHIL15CT00591AA 3

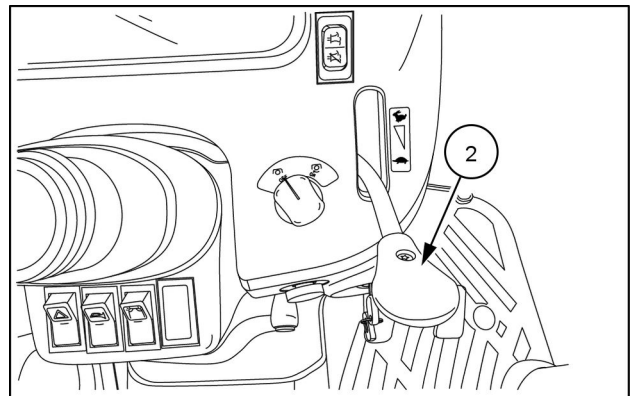

NHIL15CT00592AA 4

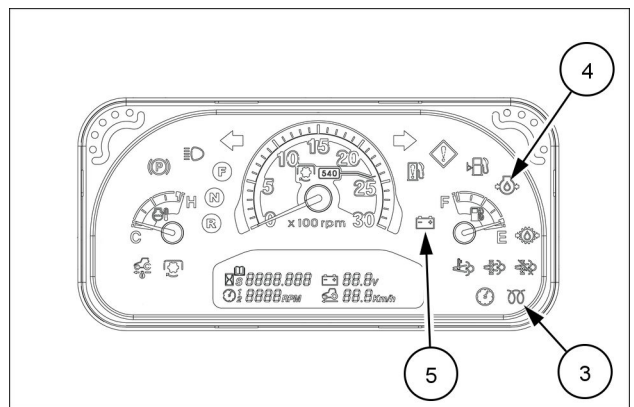

NHIL16CT00387FA 5

Operator presence system (start operation)

Operator	Rear PTO	Mid PTO	Transmission	Park Brake	Clutch Pedal	Condition
Out of Seat	Off	Off	HST pedals in Neutral	Engaged	NA	Start *
Out of Seat	Off	Off	HST pedals in Neutral	Disengaged	NA	Start with Alarm *
In Seat	Off	Off	HST pedals in Neutral	Engaged	NA	Start
In Seat	Off	Off	HST pedals in Neutral	Disengaged	NA	Start with Alarm

* It is not recommended to start the tractor when you are out of the operator's seat.

NOTE: For starting, if Rear PTO or Mid PTO is engaged, tractor will not start.

Operator presence system (run operation)

NOTE: The following conditions are for when the engine is running and the operator gets out of the seat.

Rear PTO	Mid PTO	Transmission	Park Brake	Condition
Off	Off	Neutral	Disengaged	Alarm
On	Off	Neutral	Engaged	No Alarm
On	Off	Neutral	Disengaged	Alarm
Off	Off	HST pedal depressed	Either	Shutdown
On	Off	HST pedal depressed	Either	Shutdown
On	On	HST pedal depressed	Either	Shutdown
Off	On	Neutral	Either	Shutdown

Starting the engine with jumper cables

⚠ WARNING

Unexpected machine movement!

Always sit in the operator's seat to operate the machine. **DO NOT** bypass the key start switch. Sudden and unexpected machine movement or machine runaway could result.

Failure to comply could result in death or serious injury.

W0464A

⚠ WARNING

Explosion hazard!

When jump-starting the machine, connect and disconnect the jumper cables exactly as indicated in this manual. **DO NOT** connect the jumper cables to the machine battery terminals. Make sure no persons are near the connecting points before starting the engine. Start the engine from the operator's seat.

Failure to comply could result in death or serious injury.

W0342A

⚠ WARNING

Explosive gas!

Batteries emit explosive hydrogen gas and other fumes while charging. Ventilate the charging area. Keep the battery away from sparks, open flames, and other ignition sources. Never charge a frozen battery.

Failure to comply could result in death or serious injury.

W0005A

If you must use jumper cables to start the tractor:

1. Shield your eyes.
2. Connect the red end of the jumper cable to the positive (+) battery terminal **(1)** on the tractor and connect the other red end to the positive (+) battery terminal **(2)** on the auxiliary battery.
3. Connect the black end of the jumper cable to the negative (-) battery terminal **(3)** on the auxiliary battery, then connect the other black end to a tractor frame ground or engine ground **(4)**. Finally, start the tractor by following the safe starting procedures outlined under See **4-19** or **4-22**.
4. When the engine starts allow the engine to idle, and turn on all electrical equipment (lights, etc.) This will help protect the alternator from possible damage due to changes in load when disconnecting the jumper cables.
5. Disconnect the jumper cables in reverse order, disconnect the black end from the tractor frame or engine ground **(4)** then disconnect the other black end from the negative (-) battery terminal **(3)** on the auxiliary battery.
6. Disconnect the red end from the positive (+) battery terminal **(2)** on the auxiliary battery.
7. Remove the other red end from the positive (+) battery terminal **(1)** on the tractor battery.

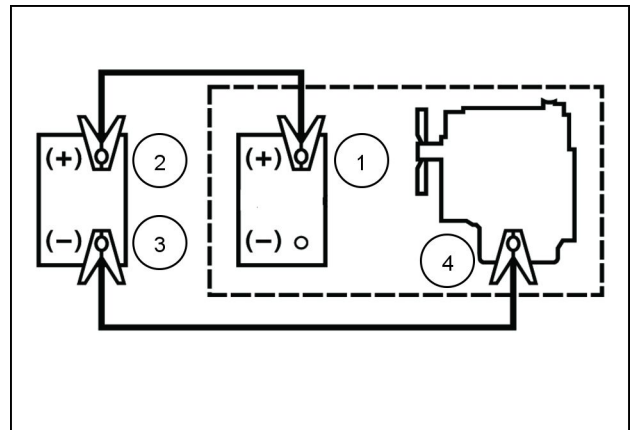

20100878 1

Stopping the unit

Stopping the engine

To stop the engine, carry out the following procedures:

1. Remain in the operator seat.
2. Pull the hand throttle lever rearward to the idle position.
***NOTICE:** After heavy work of the tractor, allow the engine to run at idle for approximately five minutes to allow the engine components to cool down.*
3. Engage the park brake.
4. Ensure all gear shift levers, range levers or shuttle shift lever are in the neutral position and the Power Take Off (PTO) switch is in the OFF position.
5. Push the Hydraulic Power Lift (HPL) control lever forward to lower implements to the ground.
6. Turn the key to the STOP position to shut the engine off.

***NOTE:** Turning the key to the STOP position and with the park brake NOT engaged, an alarm will sound. The alarm will continue to sound for approximately ten seconds or until the park brake is engaged.*

***NOTE:** If the key is not left in the STOP position after the engine has stopped, the warning lights will remain on and discharge the battery.*

Emergency stopping the engine

Mechanical transmission model

To make an emergency stop carry out the following procedures:

1. Depress the clutch pedal **(1)** and brake pedals **(2)** at the same time.
2. Pull the hand throttle lever **(3)** rearward to reduce the engine speed.

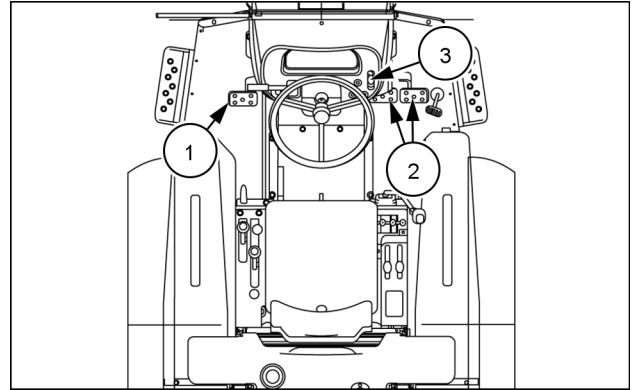

93100852 1

HST model

To make an emergency stop carry out the following procedures:

1. Release the HST forward or reverse pedal **(1)** immediately and depress the brake pedals **(2)**.
2. Pull the hand throttle lever **(3)** rearward to reduce engine speed.

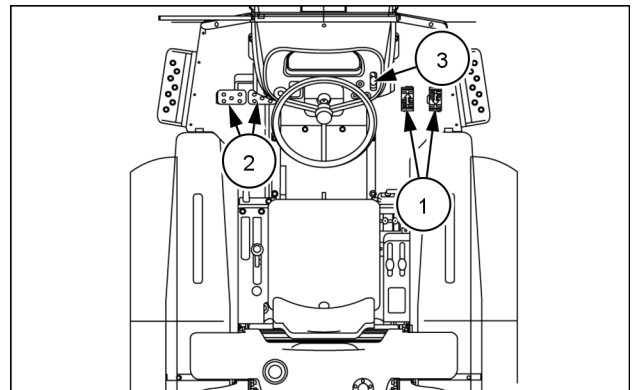

93100853 2

Brakes

⚠ WARNING

Loss of control hazard!

Always reduce the traveling speed and use the steering wheel while you make a turn. When you operate the machine at high speeds, never attempt to make sharp turns by using the turning brake pedals. If you use the individual brakes at high speeds, the machine could become machine unstable. Failure to comply could result in death or serious injury.

W1237A

Brake pedals

The right brake pedal controls the braking action of the right rear wheel. The left brake pedal controls the braking action of the left rear wheel.

The function of the brake pedals are identical for the HST and mechanical model tractors except for the location of the pedals. The brake pedals (1) on a HST model tractor are located on the left-hand side of the operators platform and the brake pedals (2) on a mechanical model tractor are located on the right-hand side of the operators platform.

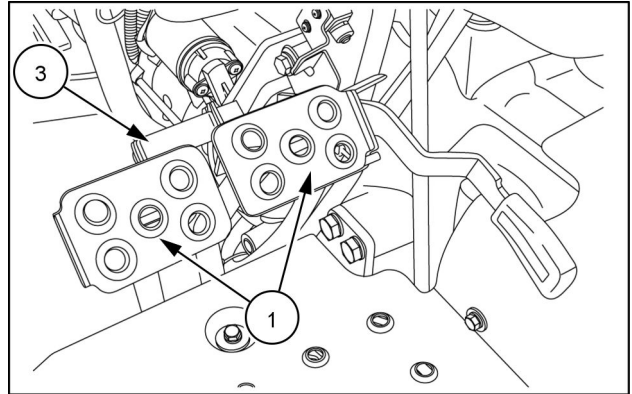

NHIL12CT00691AA 1

Stopping the tractor

To stop a mechanical model tractor, depress both brake pedals and the clutch pedal simultaneously.

To stop a HST model tractor, release the HST forward or reverse pedal and depress both brake pedals simultaneously.

NOTE: To assist in making sharp turns at slow speed, depress the right or left brake pedal as required.

NOTE: Depressing the brake pedals will disengage the HST cruise control.

Brake pedal lock

The brake pedal connecting pin (3) is used to secure the brake pedals together. Lock the pedals together whenever the tractor is operated at high speeds or when the tractor is used on the highway.

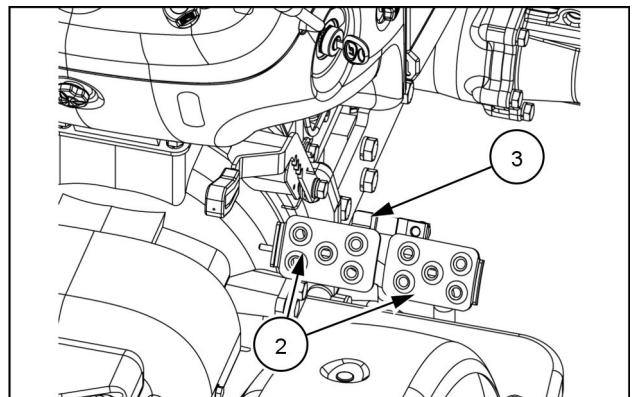

NHIL12CT00775AA 2

Park brake

⚠ WARNING

Unexpected movement!

Always engage the parking brake and switch off the engine before exiting the machine.

Failure to comply could result in death or serious injury.

W0209A

NOTICE: Ensure the park brake is fully disengaged before driving the tractor.

The park brake lever is located on the left-hand side of the operators platform **(1)** on HST tractors and on the right-hand side of the operator's platform **(2)** on mechanical model tractors. The park brake is used to secure the brake pedals to prevent the tractor from moving while parked.

To engage the park brake, lock the pedals together and push down on the park brake lever while depressing the brake pedals **(3)**.

NOTE: Always engage the park brake when getting off the tractor. If the park brake is not engaged or the operator leaves the seat without engaging the park brake, a alarm will sound. The alarm will continue to sound for approximately ten seconds or until the park brake is engaged.

To disengage the park brake, press the brake pedals down and release the park brake lever and push the lever down.

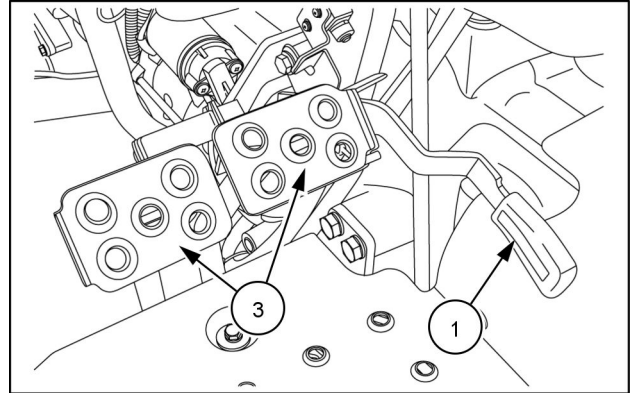

NHIL12CT00691AA 3

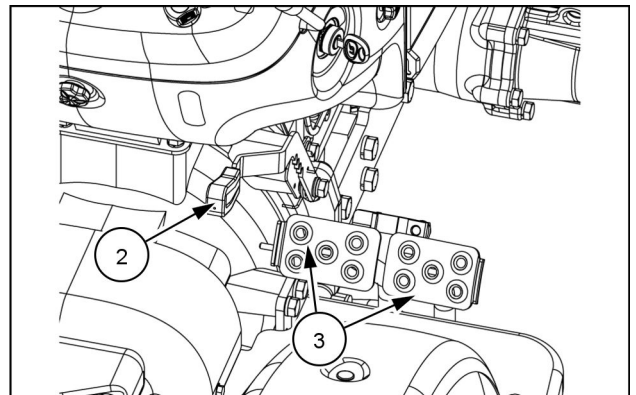

NHIL12CT00775AA 4

Moving the unit

Steering wheel - Adjust

The tractor is equipped with an adjustable steering wheel which can tilt. The tilt steering lever (1) is located on the right-hand side of the steering column.

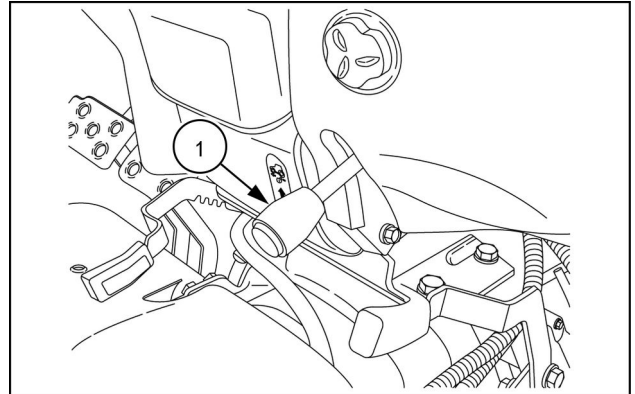

NHIL15CT00248AA 1

To adjust position of steering wheel:

1. Push downwards (A) on lever (1) and position steering wheel as needed.
2. Pull upwards (B) on tilt steering lever to lock steering wheel in place

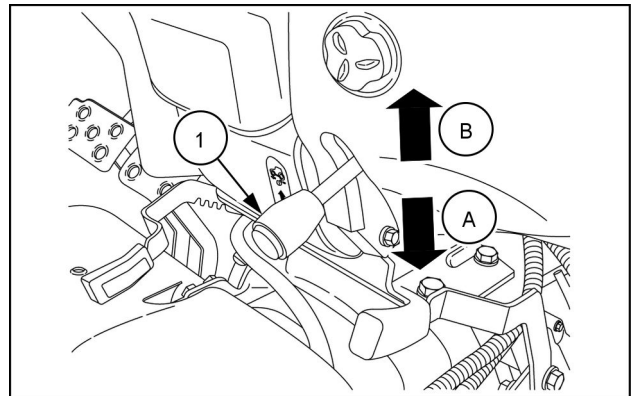

NHIL15CT00248AA 2

Steering - Operation

The tractor has a hydraulic steering system which provides convenience when operating the steering wheel. A non-load reaction system keeps the steering wheel from moving when the impact of the front wheels travel over rough ground.

Operating notes

- If there is too much of a load in the front bucket, it could be difficult to operate the steering wheel. In this case, reduce the size of the load or move the tractor slowly forward while turning the steering wheel in the direction of desired travel.
- After turning the steering wheel fully, do not turn the steering wheel fully to the same direction again. Unnecessary force is applied, which could damage the steering system.

NOTICE: Do not hold the steering wheel fully to the left or right for more than 10 seconds, it could cause a failure in the steering system.

- If an abnormal sound is heard while operating the steering wheel, this means that there is some air in the steering components line. In this case, turn the steering wheel to left and right fully and hold for about 5 seconds. The air should bleed out and the abnormal noise should go away. If the sound does not go away take your tractor to your authorized NEW HOLLAND dealer.
- When operating the tractor in cold weather, the abnormal sound may be heard. In this case, warm up the tractor before using to reduce the oil viscosity.
- If you use the tractor for a long period of time while turning the steering wheel fully, the oil temperature will increase which may cause the reduction of the product life or the failure of the hydraulic steering system.

NOTE: If the engine stops, the hydraulic power for the steering system will stop. The lose of hydraulic power will make the steering wheel hard to turn.

Transmission - Warm-up

Warm up period

⚠ WARNING

Unexpected movement!

During the warm-up operation, do the following: Engage the parking brake, set all shift levers to their NEUTRAL positions, and place the Power Take-Off (PTO) clutch lever in the OFF position. Failure to comply could result in death or serious injury.

W1247A

The tractor hydraulic oil also serves as the tractor transmission fluid. During cold weather operation, the hydraulic oil viscosity increases. This increase in oil viscosity restricts the oil's ability to flow and lubricate in the transmission and hydraulic circuits. The cold oil can result in abnormal noises and slower operation times due to the increased oil viscosity.

NOTE: A warm up time at 50% rated engine speed is recommended to assure proper vehicle functionality, transmission lubrication and operation.

NOTE: Do not operate the tractor under full load condition until the hydraulic oil is sufficiently warmed up.

Ambient Temperature	Recommended Warm-Up Time
Above 0 °C (32 °F)	Minimum of 5 minutes
0 – -10 °C (32 – 14 °F)	5 to 10 minutes
-10 – -20 °C (14 – -4 °F)	10 to 15 minutes
Below -20 °C (-4 °F)	More than 15 minutes

Hydrostatic transmission - Operation

The ground speed of tractors equipped with a hydrostatic transmission is continuously variable, from zero to full rated speed in each range. Speed is controlled by the HST forward (1) and reverse (2) pedals located on the right-hand operators platform.

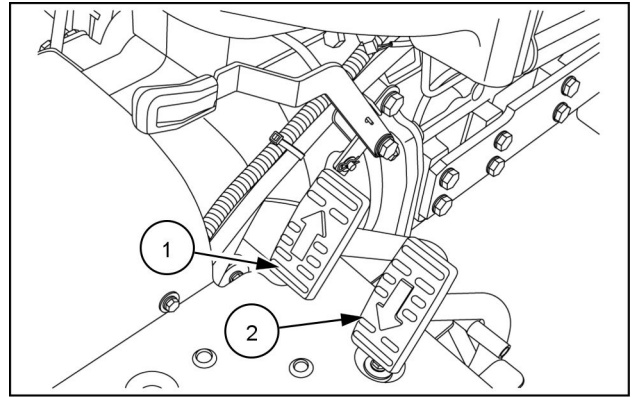

NHIL12CT00693AA 1

To operate the HST transmission, carry out the following:

1. Start the engine and pull the HPL control lever (1) rearward to lift the implement off the ground (if equipped).
2. Move the hand throttle lever (2) forward until the engine speed is above **1500 RPM**.
3. Place the range gear shift lever (3) in the desired range.
4. Depress the brake pedals (4) and disengage the park brake lever (5).
5. For forward travel, depress the forward pedal (6) until the desired ground speed is reached. For reverse travel, depress the rear pedal (7). The transmission returns to neutral and the tractor stops when the pedal is released.

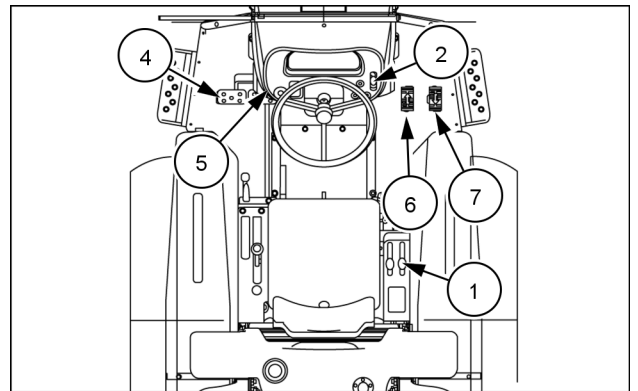

93100853 2

NOTE: Depress the HST pedals slowly, fast movement of the pedals will cause the tractor to move suddenly.

NOTE: To change the range speed, release the HST pedals and bring the tractor to a stop and select the desired range.

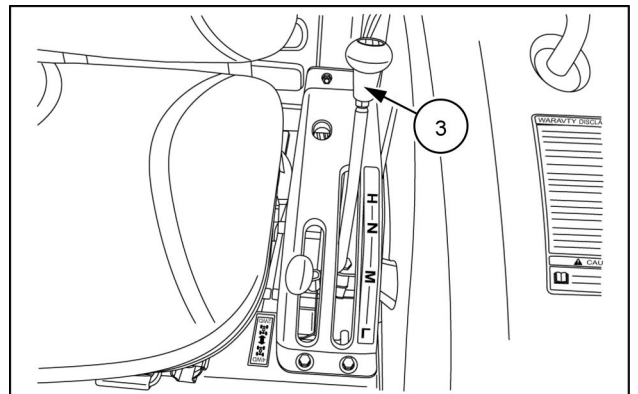

NHIL12CT00680AA 3

Cruise control operation

⚠ WARNING

Loss of control hazard!

To maintain optimum control of the machine, do not use the cruise control at high speeds or when roading.

Failure to comply could result in death or serious injury.

W0978A

When the desired travel speed is reached, push down on cruise control lever (1). The cruise control linkage will mechanically engage the HST forward pedal (2) and maintain the pedal at the desired position. . To disengage the cruise control, (2) depress both brake pedals.

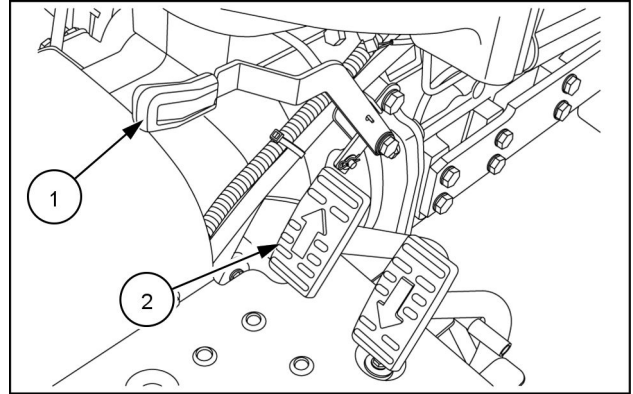

NHIL12CT00693AA 4

Mechanical transmission external controls - Operation

The 12 x 12 mechanical transmission operates through the use of a clutch pedal (1) a forward/reverse shuttle shift lever (2) main transmission shift lever (3) and a range selector lever (4).

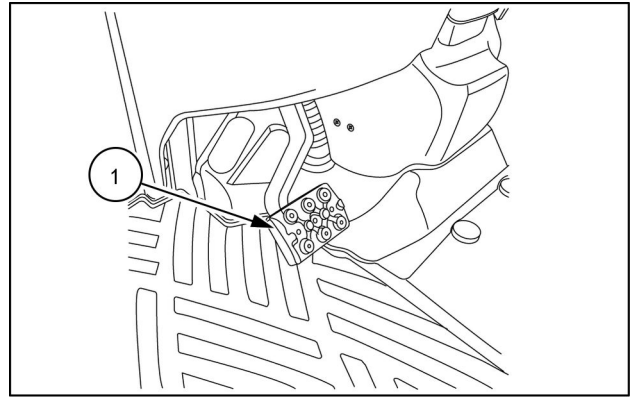

NHIL13CT01179AA 1

The combinations of shuttle shift, main shift, and range selector lever offer the operator a combination of twelve forward and twelve reverse gears.

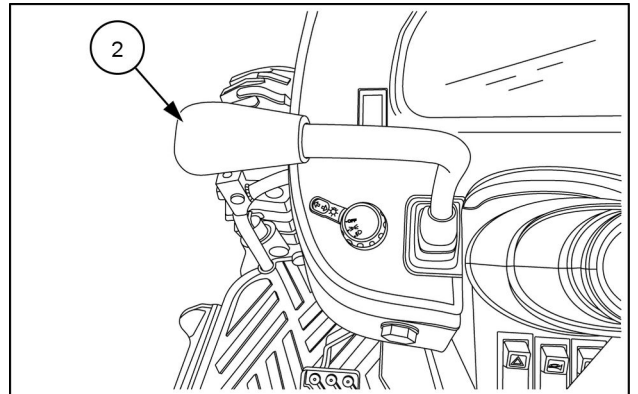

NHIL13CT01090AA 2

The main transmission shift lever (3) operates in a H-pattern. To change gears while in a selected range, depress the clutch pedal and shift the main gear shift lever into the desired gear. The tractor must be stopped because the main speed gears (1-4) are not synchronized.

NOTE: The shift pattern is shown as sitting in the operators seat.

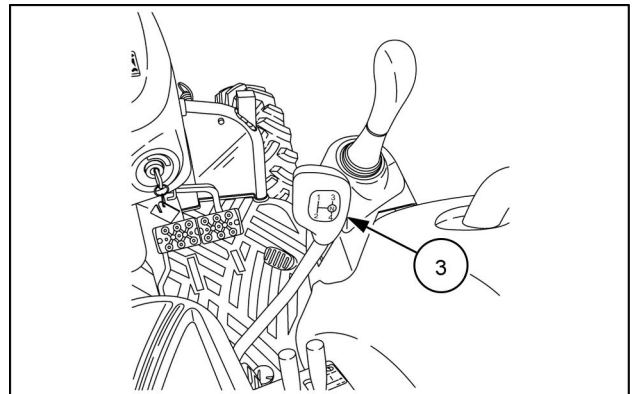

NHIL13CT01192AA 3

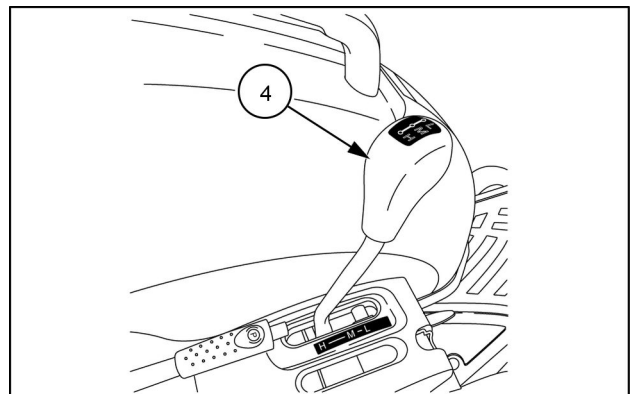

NHIL13CT01194AA 4

To operate the 12 x 12 mechanical transmission, carry out the following:

1. Start the engine and pull the HPL control lever **(1)** rearward to lift the implement off the ground (if equipped).
2. Move the hand throttle lever **(2)** forward until the engine speed is above **1500 RPM**.
3. Depress the clutch pedal **(3)** fully.
4. Place the main transmission shift lever **(4)** shuttle shift lever **(5)** and range lever **(6)** into the desired position.
5. Depress the brake pedals **(7)** and disengage the park brake lever **(8)**.
6. Release the clutch pedal **(3)** slowly, and the tractor will start to move.

NOTE: To change gears, depress the clutch pedal fully, stop the travel of the tractor and shift into the desired gear. Release the clutch pedal slowly to prevent sudden tractor movement.

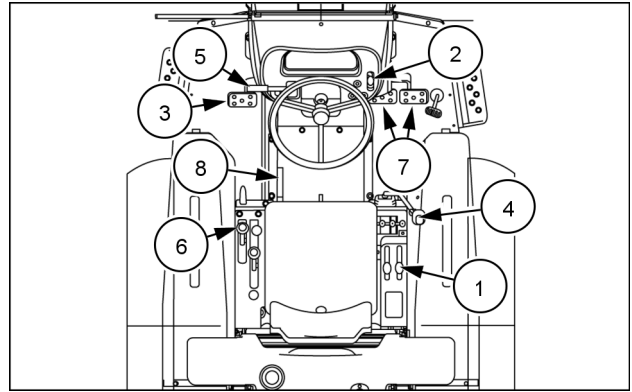

93100852 5

Parking the unit

Parking the tractor

⚠ WARNING

Avoid injury! Always do the following before lubricating, maintaining, or servicing the machine.

1. Disengage all drives.
 2. Engage parking brake.
 3. Lower all attachments to the ground, or raise and engage all safety locks.
 4. Shut off engine.
 5. Remove key from key switch.
 6. Switch off battery key, if installed.
 7. Wait for all machine movement to stop.
- Failure to comply could result in death or serious injury.

W0047A

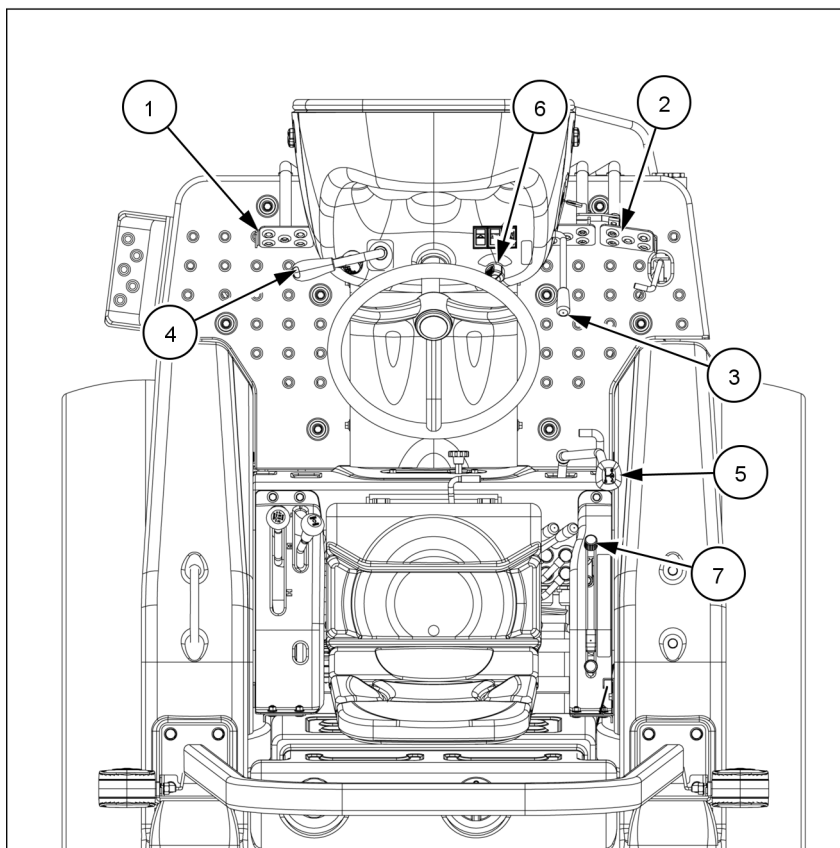

NHIL12CT00891GA 1

Mechanical model

To park the tractor carry out the following procedures:

1. Depress the clutch pedal (1) and brake pedals (2). Pull the hand throttle lever (3) rearward to reduce the engine speed.

NOTE: Park the tractor on a level surface, if it is necessary to park on a slope, place the transmission in the lowest gear and place chocks or blocks in front or behind the tires depending on the direction of the slope.

2. Place the shuttle shift lever (4) main gear shift lever (5) in neutral and make sure the PTO switch (6) is in the "OFF" position.
3. Push the HPL control lever (7) forward to lower implements (if equipped) to the ground.

4 - OPERATING INSTRUCTIONS

4. Turn the key **(8)** to the "STOP" position.

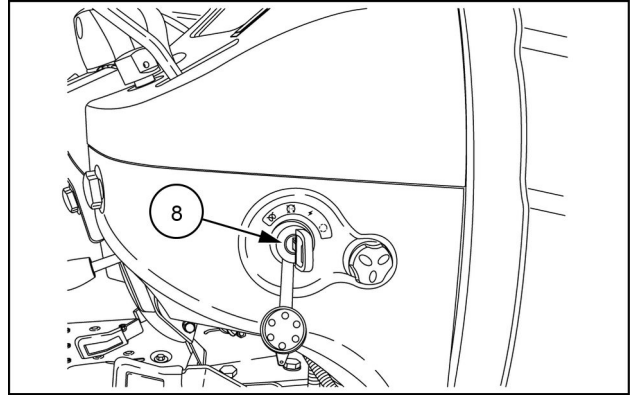

NHIL15CT00245AA 2

5. Engage the park brake **(9)** and release the brake pedals and clutch pedal slowly.

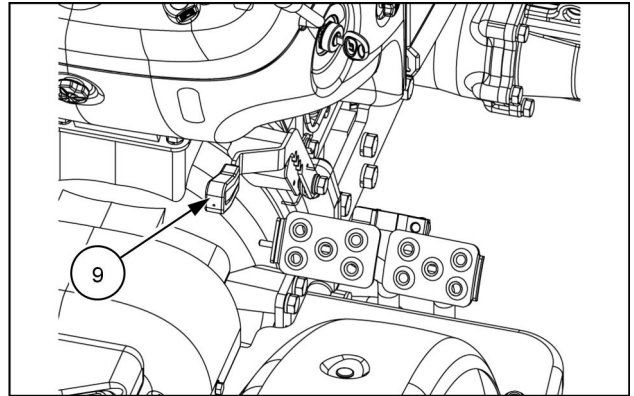

NHIL12CT00775AA 3

HST model

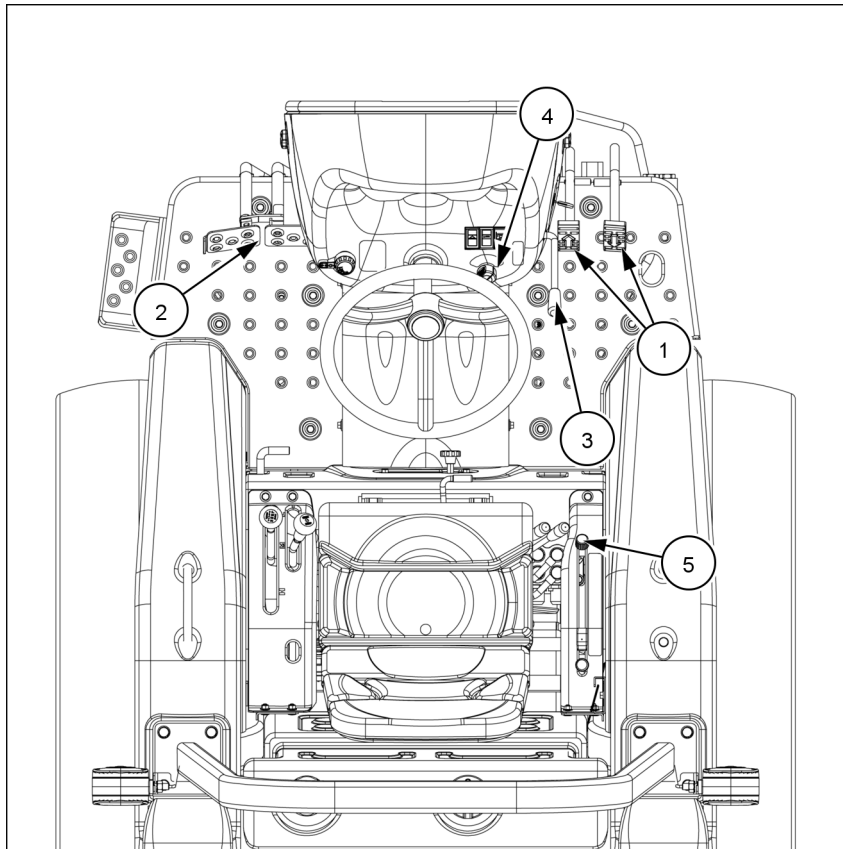

NHIL12CT00892GA 4

To park the tractor carry out the following procedures:

1. Release the HST forward or reverse pedal (1) slowly and depress the brake pedals (2). Pull the hand throttle lever (3) rearward to reduce the engine speed.

NOTE: Park the tractor on a level surface, if it is necessary to park on a slope, place the range gear shift lever in the lowest gear and place chocks or blocks in front or behind the tires depending on the direction of the slope.

2. Make sure the PTO switch (4) is in the "OFF" position.
3. Push the HPL control lever (5) forward to lower implements (if equipped) to the ground.
4. Turn the key (6) to the "STOP" position.

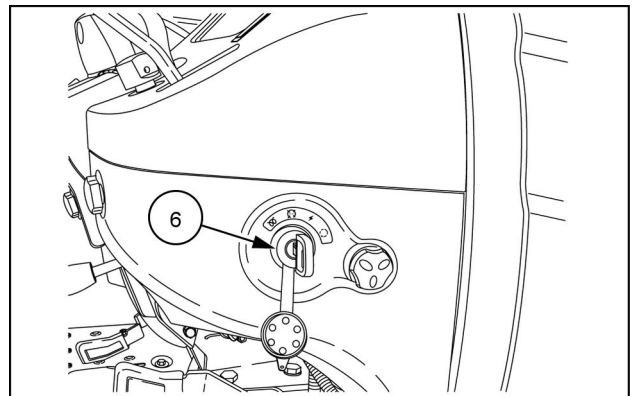

NHIL15CT00245AA 5

5. Engage the park brake **(7)** and release the brake pedals slowly.

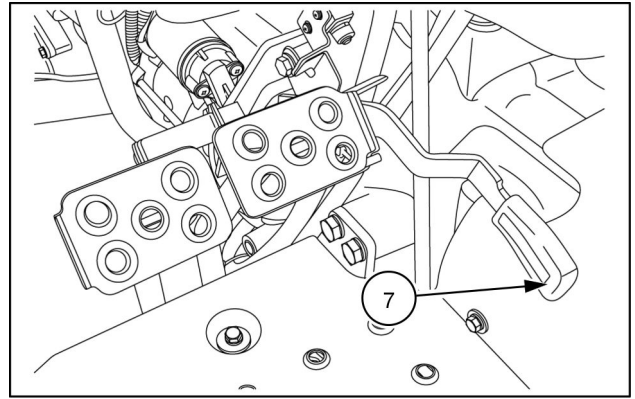

NHIL12CT00691AA 6

5 - TRANSPORT OPERATIONS

Road transport

External lighting

Your tractor is equipped with:

- Turn signal/hazard side warning lights **(1)**.
- Rear amber warning lights **(2)**
- Rear red tail/brake lights **(3)**.
- Road lights **(4)** Work Lights **(5)**.

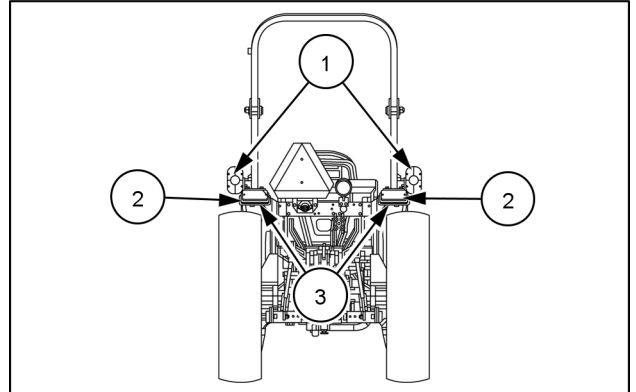

NHIL23CT00448AA 1

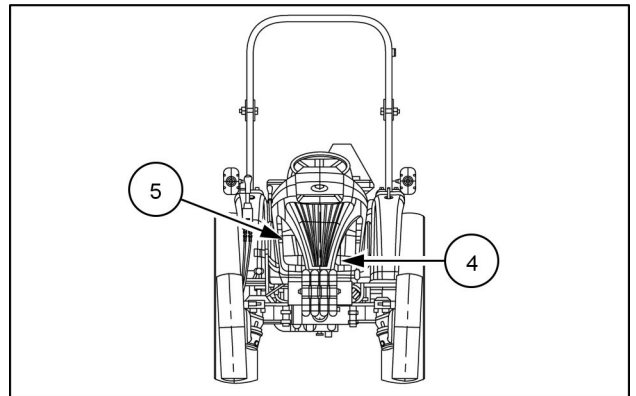

NHIL23CT00446AA 2

Turn signal / Hazard lights - Identification

The hazard warning lights (1) are activated by rotating the multifunction switch located on the left-hand side of the dash panel.

NOTE: The hazard lights can function with the key in any position.

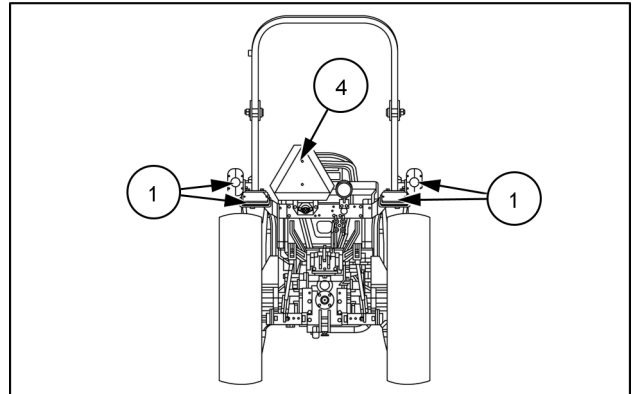

NHIL23CT00448AA 1

To activate the hazard lights rotate the switch until the "HAZARD" symbol (2) is aligned with the index mark (3) on the switch lever.

NOTE: For your protection, use the hazard warning lights, the SMV (Slow Moving Vehicle) sign (4) and road lights (low beam) when traveling on public roads, day or night. Rotate the light switch until the "LOW BEAM" and "HAZARD" symbols (5) are aligned with the index mark (3) on the switch lever.

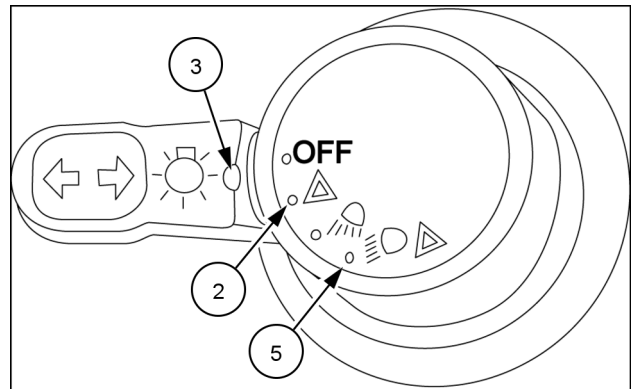

93099370 2

Turn signal / Hazard lights - Operation

The turn signal lights are activated by moving the multifunction switch lever (1) forward for right turns and down for left turns. The key has to be in the "ON" position for the turn signal to operate.

NOTE: The multifunction switch is located on the left-hand side of the dash panel.

When signaling a turn, the designated side amber light and hazard light (2) will flash.

NOTE: If the flashing hazard warning lights are operated at the same time when the turn signal is activated, the hazard light for the opposite side of turning direction will stop flashing and illuminate continuously.

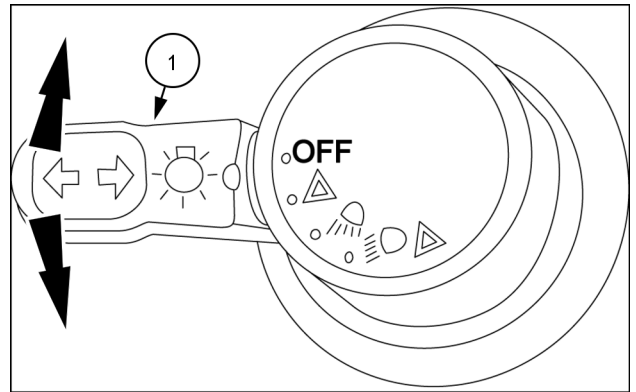

93099370 1

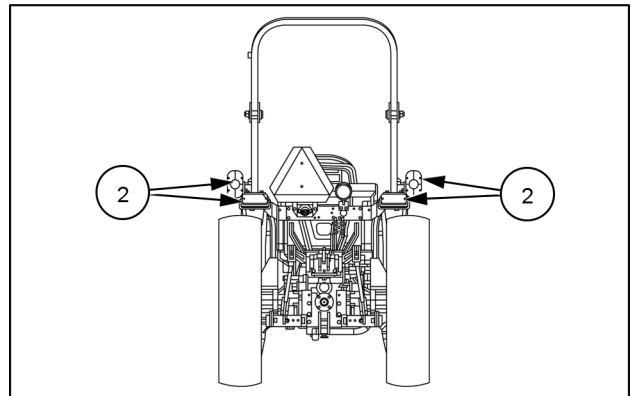

NHIL23CT00448AA 2

Road lights - Operation

The road lights (1) rear red taillights (2) and rear/side hazard lights (3) are turned on and off using the multifunction light switch located on the left-hand side of the dash panel. The key switch must be in the "ON" position for these lights to operate.

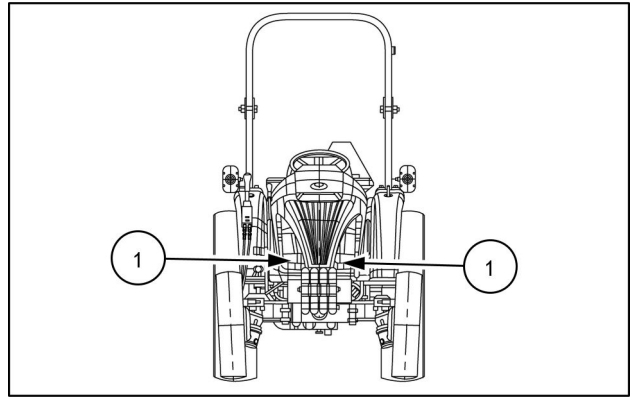

NHIL23CT00446AA 1

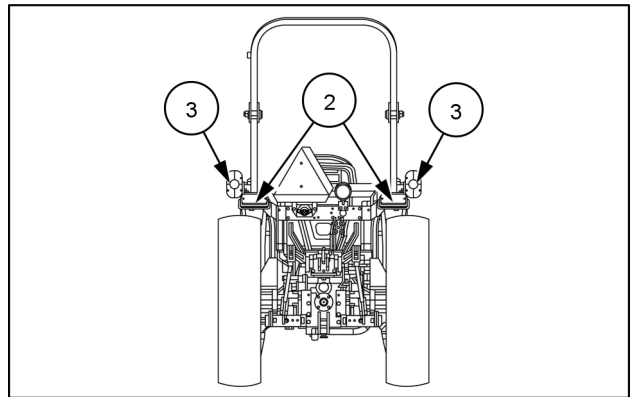

NHIL23CT00448AA 2

To operate the road lights, taillights and hazard lights, rotate the multifunction switch (4) until the "LOW Beam" and "HAZARD" symbols (5) are aligned with the index mark (6) on the switch lever. The instrument panel, taillights, road lights and hazard lights will illuminate.

NOTE: For your protection, use the hazard warning lights, road lights and SMV (slow moving vehicle) sign when traveling on public roads, day or night.

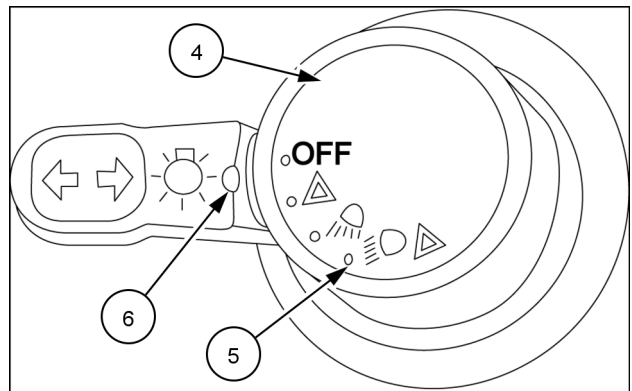

93099370 3

Work lights - Operation

The work lights **(1)** are turned on and off using the multifunction light switch located on the left-hand side of the dash panel. The key switch must be in the "ON" position for these lights to operate.

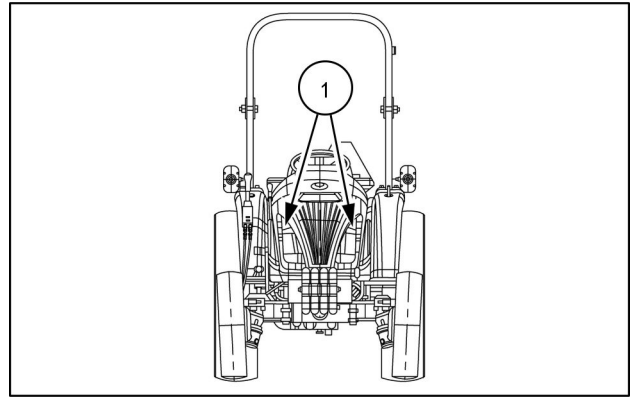

NHIL23CT00446AA 1

To operate the work lights, rotate the multifunction switch **(2)** until the "WORK LIGHT" symbol **(3)** is aligned with the index mark **(4)** on the switch lever. The instrument panel, red taillights and work lights will illuminate.

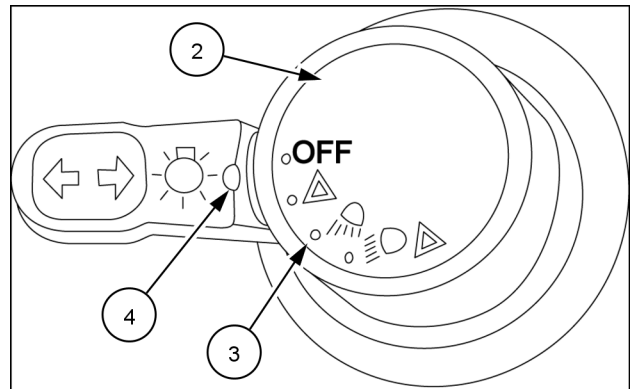

93099370 2

Brakes and controls - Driving

Observe the following precautions when driving the tractor:

- Watch where you are going at all times, especially at row ends, on roads, and around trees.
- Use the hazard warning lights, road lights (low beam), and SMV (slow moving vehicle) sign when travelling on public roads, day or night.
- DO NOT permit anyone but the operator to ride on the tractor.
- Lock the brake pedals together when travelling on public roads.
- Make sure the PTO switch is in the "OFF" position.
- Keep the tractor in gear when going downhill. Use a low gear to maintain control with minimum braking.
- If the tractor becomes stuck, back out to prevent upsetting the unit.
- Always use the drawbar for pull-type work. Do not pull from any other part of the tractor, since it may tip backward.

NOTICE: *When transporting on the highway, a safety chain with tensile strength equal to the gross weight of the implement should be connected between the tractor and the towed implement. This will control the implement in the event the hitch pin is lost. After attaching the safety chain, check its adjustment by driving the tractor to the right and to the left for a short distance. Readjust to tighten or loosen the chain as necessary. Safety chains and suitable hardware are available from your NEW HOLLAND Dealer.*

NOTE: *Procure attaching hardware locally. Check implement assembly or the Operator's Manual for attaching hardware specifications, such as bolt size and grade, chain strength, washers, lock washers, nuts, etc.*

- Engage the clutch slowly when driving out of a ditch, gully, or up a steep hillside. Immediately disengage the clutch if the front wheels should rise off the ground.
- Reduce speed before turning quickly or applying brakes.
- To make an emergency stop, depress both brake pedals and the clutch pedal (mechanical transmission model only) simultaneously

NOTE: *When making an emergency stop while operating a HST model tractor depress both brake pedals and release the forward or reverse HST pedal.*

- Never apply the differential lock when turning.
- Use extreme caution and avoid hard applications of the tractor brakes when pulling heavy, towed loads at road speeds.
- Any towed vehicle with a total weight exceeding that of the towing tractor should be equipped with brakes for safe operation.
- Always sit in the driver's seat while starting or driving the tractor.
- Always check overhead clearance, especially when transporting the tractor.

Shipping transport

Transporting by truck or trailer

NOTICE: Do not hook the chains around the steering cylinders, tie rods or the axles. These components could be damaged by the chain or by excessive strain.

NOTE: Use suitable equipment or facilities when loading and unloading the tractor.

Transport the tractor with all four wheels on a flatbed trailer or truck. Secure the tractor as follows:

- Secure the front of the tractor at the front of the frame.
- Secure the rear of the tractor at the rear drawbar/hitch .

Recovery transport

Brakes and controls - Towing

Towing the tractor

⚠ WARNING

Hazard to bystanders!

Do not use cables or rope to tow the machine. If the cable or rope breaks or slips, it may whip back with enough force to cause serious injury. When using a chain, attach the chain with the hook's open side facing UP. If the hook slips, it will drop down instead of flying up.

Failure to comply could result in death or serious injury.

W0941A

⚠ WARNING

Unexpected machine movement!

Never attempt to start the machine by towing. The machine could start unexpectedly.

Failure to comply could result in death or serious injury.

W0941A

⚠ WARNING

Transport hazard!

Do not tow the machine on public roads. Towing could cause a safety hazard for other vehicles using the roadway.

Failure to comply could result in death or serious injury.

W1012A

NOTICE: If it is necessary to tow the tractor, all gear levers must be moved to the neutral position before stopping the engine otherwise damage to transmission components may occur during towing.

Use a strong chain when towing the tractor. Tow the tractor from the rear using only the drawbar. Tow the tractor from the front using the tow pin in the front weights or front support. Have an operator steer and brake the tractor. If possible, run the engine to provide lubrication to the transmission and power steering.

Place the transmission gearshift levers in neutral, disengaged the 4WD, differential lock and park brake to tow the tractor. Do not exceed **20 km/h (12 mph)**.

NOTE: The tractor should only be towed a short distance, such as out of a building. Do not tow on roadways or as a method of transport.

Towing implements

▲ WARNING

Loss of control hazard!
Always attach or pull towed vehicles from the tractor drawbar.
Failure to comply could result in death or serious injury.

W1013A

For towed vehicles without brake system:

- Do not exceed transport speed of **32 km/h (20 mph)**.
- Do not exceed fully loaded mass (weight) of 1.5 times the mass (weight) of the towing unit.

For towed vehicles with brake system:

- Do not exceed transport speed of **32 km/h (20 mph)**.
- Do not exceed fully loaded mass (weight) of 4.5 times the mass (weight) of the towing unit.

6 - WORKING OPERATIONS

General information

Ballast

For sufficient traction and maximum performance in heavy draft operations, and to counterbalance rear-mounted equipment, weight should be added to the tractor in the form of liquid ballast, cast iron weights, or a combination of both. Only enough weight should be added to provide good traction and stability. Adding more weight than is needed results in unnecessary soil compaction, increased rolling resistance, and higher fuel consumption.

NOTE: When adding weight to the tractor, tire pressures may need to be increased. See **7-30**.

Front end ballast may be required for stability and steering control when weight is transferred from the front wheels to the rear wheels as an implement is raised by the tractor three-point hitch.

As a general guide:

Ballast the tractor (less implement) so that approximately one-third of the tractor weight is on the front wheels. For optimum traction, tractors equipped with 4WD should be ballasted so that **40 – 45%** of machine weight is on the front wheels.

When a rear mounted implement is raised to the transport position, the front wheel reaction should be at least **20%** of tractor weight.

Add additional front end ballast as required for stability during operation and transport. Tractor front end ballast may not always maintain satisfactory stability if the tractor is operated at high speed on rough terrain. Reduce tractor speed and exercise caution under these conditions.

When using front-mounted equipment, add weight to the rear axle to maintain good traction and stability. Front-mounted equipment varies in weight. Refer to equipment manual for ballasting.

Weighting limitations

The weighting limitations that follow are limitations only. They do not imply that the tractor should be weighted to attain the weights given. Use only enough weight to obtain good performance.

Ballast weight requirements

Cast iron weights (Optional)

Cast iron weights are available as accessories from your NEW HOLLAND Dealer. Weights can be mounted on the front end of the tractor, rear of the tractor and on the rear wheels.

Front weight carrier bracket (Optional)

To mount cast iron weights on the front of the tractor an optional extension mounting bracket (1) must be installed on the front of the tractor frame. When the extension bracket is installed, a maximum of five front weights can be installed.

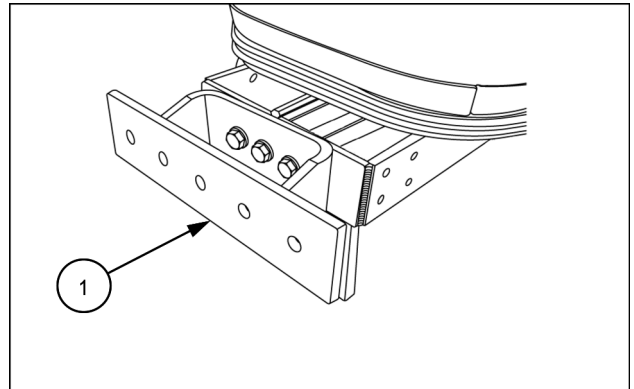

NHIL15CT00402AA 1

Weight options:

A maximum of five **27 kg (60 lb)** weights (A) for a total weight of **135 kg (300 lb)**.

A maximum of three **45 kg (100 lb)** weights (B) for a total weight of **135 kg (300 lb)**.

NOTE: The front extension mounting bracket with a maximum of five **27 kg (60 lb)** weights or three **45 kg (100 lb)** weights attached is compatible with a grille guard.

NOTE: The front extension mounting bracket is not compatible with a loader installed.

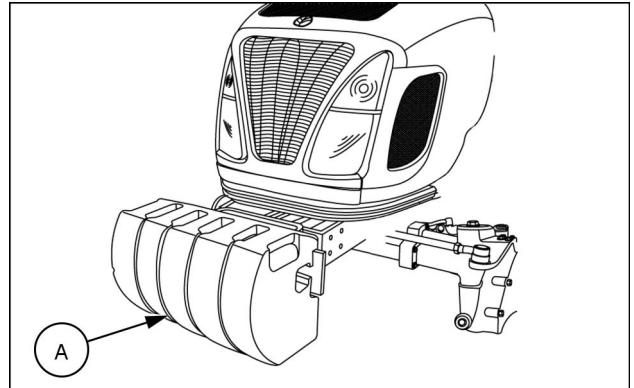

NHIL15CT00403AA 2

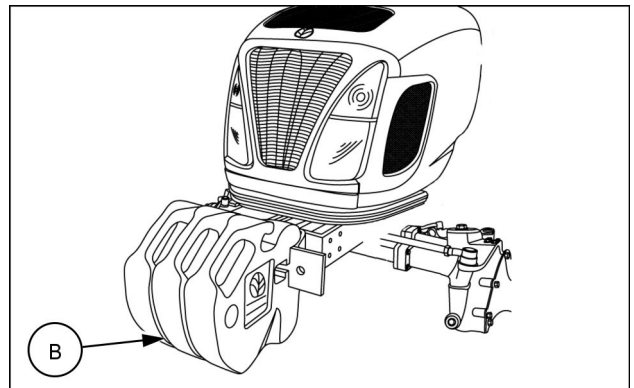

NHIL15CT00404AA 3

Rear wheel weights (Optional)

Rear wheel weights are not available for the **Workmaster™ 35/40** model tractors.

Rear counter weight bracket (Optional)

To mount cast iron weights on the rear of the tractor an optional weight bracket (1) must be installed on the rear 3-point hitch. A maximum of seven suitcase weights (2) can be fitted to the bracket.

Weight options:

A maximum of seven **27 kg (60 lb)** weights for a total weight of **191 kg (421 lb)**.

A maximum of two **27 kg (60 lb)** weights, and five **45 kg (100 lb)** weights, for a total weight of **282 kg (622 lb)**.

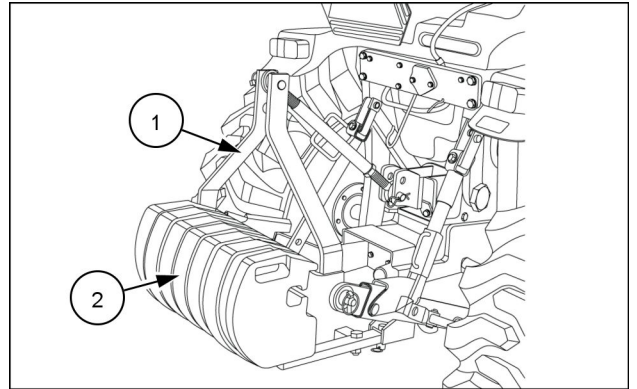

93100917 4

Ballasting box (Optional)

A category-1, 3-point hitch, **227 kg (500 lb)** capacity ballasting box (1) may be purchased as extra equipment. Load with sand, gravel, or similar loose ballast as needed.

	Weight (Empty)	Weight (Loaded)
3-Point Hitch Ballasting Box	46 kg (101 lb)	228 kg (503 lb)

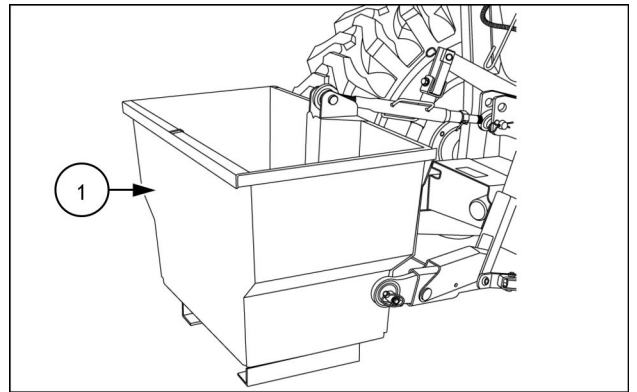

93100918 5

Liquid ballast

It is a common practice to add weight to the tractor by filling the rear tires with liquid. A calcium chloride (CaCl₂) and water solution is recommended due to its low freezing point and greater density (weight per gallon) than pure water.

Never exceed the total recommended weight for the tractor. Because special equipment is required to fill the tires, consult your NEW HOLLAND Dealer.

Tires should never be filled beyond **75%**. At **75%** full, the liquid will come to the valve stem when the valve stem is at its highest point at the top of the wheel.

Ballast Weights (Per Tire) 600 g/5 lb Gal Solution/CaCl₂.

Tire Type	Tire Size	Approximate Added Weight
Agricultural	11.2-24, 4PR, R1	115 kg (254 lb)
Turf	41 x 14.00-20, 4PR, R3	157 kg (346 lb)
Industrial (R4)	43 x 16-20 4PR, R4	234 kg (515 lb)

7 - MAINTENANCE

General information

General information

Adequate lubrication and maintenance on a regular schedule is vital to maintaining your equipment. To ensure long service and efficient operation, follow the lubrication and maintenance schedules outlined in this manual. The use of proper fuels, oils, grease and filters, as well as keeping the systems clean, will also extend machine and component life.

NOTICE: While any company can perform necessary maintenance or repairs on your equipment, NEW HOLLAND strongly recommends that you use only authorized NEW HOLLAND dealers and products that meet the given specifications. Improperly or incorrectly performed maintenance and repair voids the equipment warranty and may affect service intervals.

NOTICE: Always use genuine NEW HOLLAND replacement parts, oils and filters to ensure proper operation, filtration of engine and hydraulic systems. See your NEW HOLLAND dealer for additional oil quantities.

Regular lubrication is the best insurance against delays and repairs. Proper lubrication will extend machine life. Refer to the following charts for lubricants and service intervals.

NOTICE: Failure to complete the required maintenance at the recommended intervals can cause unnecessary downtime.

Use the intervals listed in the Lubrication Chart as guidelines when operating in normal conditions. Adjust the intervals for operating in adverse environmental and working conditions. Shorten the intervals for sandy, dusty, and extremely hot operating conditions.

▲ WARNING

Avoid injury!

1. Disengage all drives.
2. Engage parking brake.
3. Lower all attachments to the ground, or raise and engage all safety locks.
4. Shut off engine.
5. Remove key from key switch.
6. Wait for all machine movement to stop.

Failure to comply could result in death or serious injury.

W1197A

▲ WARNING

Entanglement hazard!

Disengage the Power Take-Off (PTO), turn off the engine, and remove the key. Wait for all movement to stop before leaving the operator's position. Never adjust, lubricate, clean, or unplug machine with the engine running.

Failure to comply could result in death or serious injury.

W0227A

▲ WARNING

Illustrations in this manual may show protective shielding open or removed to better illustrate a particular feature or adjustment.

Replace all shields before operating the machine.

Failure to comply could result in death or serious injury.

W0012A

Always clean the area around dipsticks, fill caps, and check plugs when checking fluid levels. Failure to clean these areas may allow contamination to enter the system. Drain, flush, and refill the system any time you suspect it is contaminated.

Grease Fittings

1. Wipe dirt from fittings before greasing.
2. Use a grease gun containing clean high grade of **MULTI-PURPOSE GREASE EP / AW / NLGI 2**.
3. Pump fresh grease into the fitting to lubricate the component and force out any contamination from the grease passage.
4. Wipe off excess grease.

General specification - Diesel fuel

Only use diesel fuel that conforms to North American standard **ASTM D975** Grade No. 2-D S15 or equivalent in your engine. Do not use any other low grade diesel fuel.

NOTICE: Use of other low grade diesel fuels will result in loss of engine power, high fuel consumption, and damage to the exhaust aftertreatment system (if equipped).

NOTE: When operating the machine in very cold climates, the use of winter blended fuel is permitted for a short period of time. See your fuel supplier for winter fuel requirements in your area.

Fuel conditioner

Diesel fuel conditioner is available from your NEW HOLLAND dealer. Instructions for the use of the fuel conditioner is on the container.

The use of diesel fuel conditioner will:

- Clean fuel injectors, valves, and manifolds for increased service life
- Disperse insoluble gummy deposits that form in the fuel system

- Separate moisture from the fuel
- Stabilize fuel in storage

NOTICE: Use only NEW HOLLAND approved biocide additives to prevent damage to the exhaust aftertreatment system (if equipped).

General specification - Biodiesel fuels

Biodiesel usage in NEW HOLLAND products

Introduction to Fatty Acid Methyl Ester (FAME) biodiesel

FAME biodiesel, called biodiesel fuel in the following section, consists of a family of fuels derived from vegetable oils treated with methyl esters.

There are two main biodiesel fuel types: Rapeseed Methyl Ester (RME) and Soybean Methyl Ester (SME). RME is a blend of rapeseed and sunflower methyl ester, and is the preferred crop in Europe. SME is the preferred crop in the United States.

Biodiesel fuel is a renewable alternative fuel source. Its use and development is promoted worldwide, especially in Europe and in the United States.

NOTICE: *Your emissions control system is compatible with up to 5% biodiesel fuel (B5). Be aware that the use of biodiesel fuel that does not comply with the standards mentioned in this section could lead to severe damage to the engine, fuel system or aftertreatment system of your machine. The use of non-approved fuels may void NEW HOLLAND Warranty coverage.*

Biodiesel can be used to run Tier 4B (final) and Stage IV diesel engines only when blended with standard diesel fuel:

- B5: indicates the blend of **5%** biodiesel and **95%** diesel fuels.
- B20: indicates the blend of **20%** biodiesel and **80%** diesel fuels. Do not use.

Biodiesel fuel has several positive features in comparison with diesel fuel:

- Biodiesel fuel adds lubricity to the fuel, which is beneficial in many circumstances, particularly as sulfur and aromatics are removed from the fuel.
- Biodiesel has a greater cetane number and burns cleaner.
- Biodiesel produces less particulate matter and reduces smoke emissions.
- Biodiesel is fully biodegradable and non-toxic.

Diesel and biodiesel fuel specifications

Tier 4B (final) and Stage IV diesel fuel specifications are covered by the following:

- **ASTM D975**, Standard Specification for Diesel Fuel Oils. (15 ppm sulfur maximum.)

Biodiesel blends are covered by:

- United States Diesel Fuel Specification **ASTM D975** allows up to **5%** biodiesel since 2009. United States fuel

suppliers are allowed to use up to **5%** biodiesel fuel (B5) to supply the network.

- United States Biodiesel Fuel Specification **ASTM D7467** provides specifications for diesel and biodiesel blends from B5 to B20.

Pure biodiesel blend stock (B100) specification is covered by the following requirements:

- **ASTM D6751** - Standard specification for biodiesel fuel blend stock (B100) for middle distillate fuels.

NOTE: *ASTM D6751 specification has been updated to improve the quality of biodiesel in the market place.*

Before raw oil can be converted into usable biodiesel fuel, it must undergo transesterification to remove glycerides. During the transesterification process, the oil reacts with an alcohol to separate the glycerine from the fat or vegetable oil. This process leaves behind two products: methyl ester (the chemical name for biodiesel) and glycerine (a byproduct usually sold for use in soaps or other products).

NOTICE: *Biodiesel fuels approved for use in the NEW HOLLAND equipment must be transesterified and comply with the latest North America Standard **ASTM D6751**.*

NOTICE: *Cold Pressed Biodiesel, Cold Pressed Oil, Straight Vegetable Oil (SVO), or more generally unrefined vegetable oils used as motor fuel, are fuels that are normally made from Rapeseed oil or similar high oil content crops. These kinds of fuel are not transesterified, so they do not fulfil the **ASTM D6751** requirements. There is no recognized quality standard available for these types of fuel. Therefore the use of Cold Pressed Biodiesel, Cold Pressed Oil, Straight Vegetable Oil (SVO), or more generally unrefined vegetable oils used as motor fuel are **NOT APPROVED** at any blend in any NEW HOLLAND product.*

NOTICE: *Any engine and fuel injection equipment fitted to a NEW HOLLAND vehicle found to have run with any blend of **NON-APPROVED** fuel (fuel not fulfilling the specification described in the requirement **ASTM D6751**) will no longer be covered for Warranty by NEW HOLLAND.*

Biodiesel fuel usage conditions

You must stringently follow the biodiesel fuel usage conditions. Incorrect application of the biodiesel fuel usage conditions could lead to severe damage to the engine, fuel injection equipment and aftertreatment system.

The main concerns related to operation with biodiesel fuels are:

- Filters and injector blockage caused by poor fuel quality.
- Wear and corrosion of internal components due to water content, which affects lubricity.

- Deterioration of some rubber sealing compounds in the fuel system.
- Biodiesel oxidation, which can lead to the formation of deposits that can harm the fuel injection system.

NOTICE: Any problem in the engine fuel injection equipment associated with non-compliance to the following conditions for biodiesel fuel handling and maintenance will not be covered for Warranty by NEW HOLLAND.

Purchase biodiesel fuel from a trusted supplier who understands the product and maintains acceptable fuel quality. The National Biodiesel Board awards **BQ-9000®** accreditation to biodiesel marketers and producers that meet strict quality and consistency standards. Biodiesel users in North America are strongly encouraged to purchase biodiesel blends from the **BQ-9000®** Certified Marketers and sourced from the **BQ-9000®** Accredited Producers found on the **BQ-9000®** website.

The use of biodiesel blends up to B5 will not void the NEW HOLLAND warranty as long as the following conditions for biodiesel fuel handling and maintenance are stringently followed:

Biodiesel fuel must be pre-blended by the supplier. Mixing biodiesel fuels on-site can result in an incorrect mixture that could damage the engine and/or fuel system.

NOTICE: NEW HOLLAND may void your warranty if the problem is associated with poor fuel quality due to improper blending. It is the responsibility of the fuel supplier and/or yourself to ensure the right type of fuel and blend is delivered and used.

Storage

The machine should not be stored for more than 6 months with biodiesel in the fuel system. For longer storage time, it is strongly suggested that only regular #2 diesel fuel is used.

NOTE: If storage for longer than 6 months is necessary, the engine must be run on regular #2 diesel for a minimum of 20 hours to flush the biodiesel fuel out of the fuel system prior to storage.

Biodiesel is highly hygroscopic and tends to collect water more than diesel fuel. This increases the risk of algae and bacteria growth which can cause severe damage to the fuel injection system. Keep the machine fuel tanks and on-site storage tanks as full as possible to limit the amount of air and water vapors inside the tank. Drain water from the tanks at least once a week.

NOTICE: Use only NEW HOLLAND approved biocide additives on Tier 4B (final) and Stage IV engines with an exhaust aftertreatment system.

Limited B10 biodiesel approval

NEW HOLLAND approves the use of up to B10 on Tier 4B (final) and Stage IV engines only in Minnesota (or other States & Provinces) where the state legislation mandates its usage during the months of April to September only and the state legislation mandates strict compliance of the B10 to specification **ASTM D7467**. The B10 must consist of a blend of S15 #2D Diesel Fuel per **ASTM D975** and B100 blend stock per **ASTM D6751** only.

Refueling the tractor

⚠ WARNING

Fire hazard!

When handling diesel fuel, observe the following precautions:

1. Do not smoke.
2. Never fill the tank when the engine is running.
3. Wipe up spilled fuel immediately.

Failure to comply could result in death or serious injury.

W0099A

The fuel tank filler cap (1) is located at the left rear corner of the tractor. Before removing the cap, wipe all dust and dirt from around the cap to prevent debris from falling into the tank while filling.

Use an approved fuel container and check the inside of the container periodically for cleanliness. Fuel tank capacity see 7-10.

NOTE: The fuel cap is a vented-type. Use only an approved NEW HOLLAND replacement cap to prevent fuel system-related problems.

If there is no filter on the storage tank or fuel container, filter the fuel through a 100-mesh or finer screen when filling the tractor fuel tank. Keep the tractor tank as full as possible (without filling to capacity) to minimize condensation.

NOTE: It is a good practice to fill the fuel tank at the end of each day, as this will reduce overnight condensation.

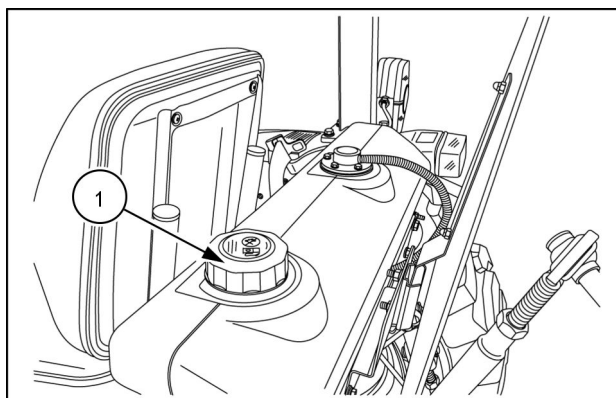

NHIL12CT00683AA 1

Change engine coolant to Organic Acid Technology (OAT) coolant

Depending on the date of manufacture, your cooling system may be equipped with conventional ethylene glycol coolant such as **IAT COOLANT 11 – CLASSIC** or an Organic Acid Technology (OAT) coolant solution such as **EXTENDED LIFE OAT COOLANT/ANTIFREEZE**. You can easily identify **EXTENDED LIFE OAT COOLANT/ANTIFREEZE** by its yellow color. You should never mix the coolant types.

The coolant solution used must meet the following CNH Industrial material specifications for either coolant type:

- **MAT3624** for OAT coolant
- **MAT3620** for conventional coolant

The decal shown is located near the fill point of the cooling system whenever the factory fill is **EXTENDED LIFE OAT COOLANT/ANTIFREEZE**. This decal is available in three different sizes. See the table below for the associated part numbers.

CNH Industrial part number	Size
47757330	50 mm x 50 mm
47757331	75 mm x 75 mm
47757332	100 mm x 100 mm

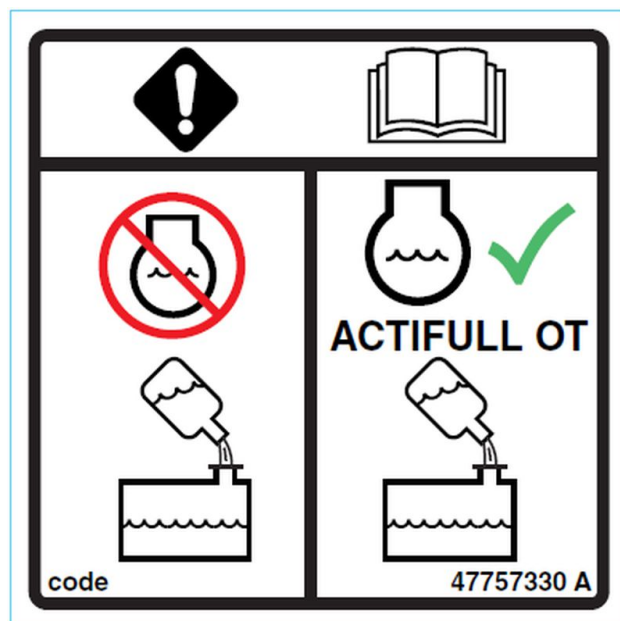

47757330 1

NOTICE: NEVER mix OAT coolant with conventional coolant. Under no circumstances should you top off a cooling system with only water. You can use a refractometer to check the concentration level. You should not use Supplemental Coolant Additives (SCA) when using **EXTENDED LIFE OAT COOLANT/ANTIFREEZE**. Change the coolant solution at the recommended change interval.

If you need to change a machine from conventional coolant to OAT coolant or vice versa, you should follow the "Changing coolant types" procedure below to attain the full benefit of the coolant.

Changing coolant types

To change coolant from OAT coolant to conventional coolant (or vice versa):

1. Empty the engine cooling system by draining the coolant into a suitable container.
2. Fill the system with clean water.
3. Start the engine and run the engine for at least **30 min**.

NOTE: Make sure that you activate the heating system (if equipped) to circulate fluid through the heater core.

4. Repeat Steps 1 to 3 for a total of two washes.
5. Fill the system with conventional coolant (or OAT coolant).
6. Operate the engine until it is warm. Inspect the machine for leaks.
7. If you are changing to OAT coolant, then attach the decal (CNH Industrial part number 47757330) to indicate the use of OAT coolant in the cooling system.

You may notice the older version of the OAT decal (CNH Industrial part number 47488993) on some applications.

Definitions

Conventional coolant:

A coolant that relies on inorganic inhibitors such as silicates, nitrites, and phosphates for corrosion and cavitation protection.

Organic Acid Technology (OAT) coolant:

A coolant that relies on inhibitors such as organic acid salts for corrosion and cavitation protection.

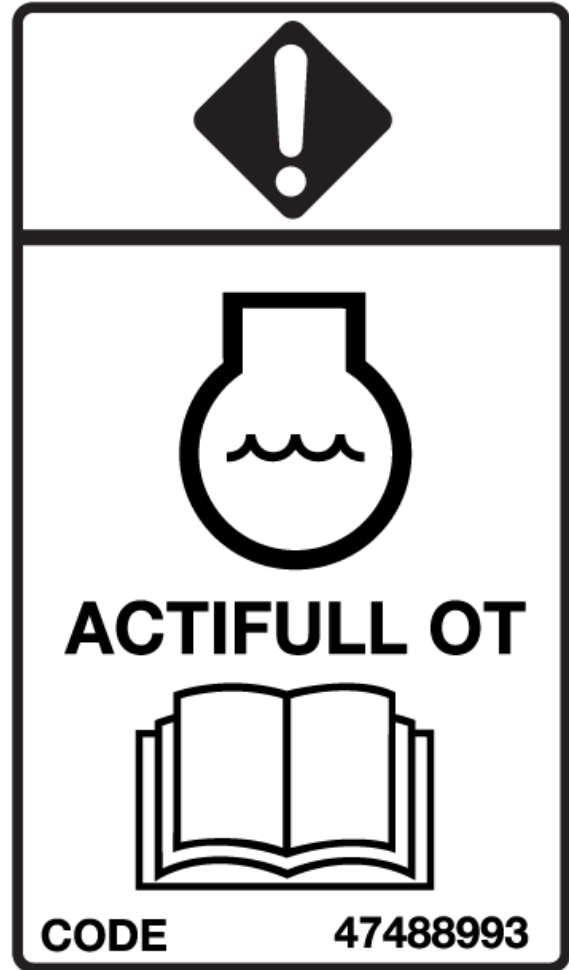

47488993 2

Fluids and lubricants

Lubricant	Type and Description
Engine Oil API CJ-4	ENGINE OIL FULL SYNTHETIC SAE 0W-40
Transmission/Hydraulic Oil	HYDRAULIC TRANSMISSION OIL - PREMIUM
	MULTI-SEASON HYDRAULIC TRANSMISSION OIL SAE 0W-20
Front Axle/Gear Oil	HYPLOID GEAR OIL EP SAE 80W-90
Grease	MULTI-PURPOSE GREASE EP / AW / NLGI 2
* Coolant	IAT COOLANT 11 – CLASSIC Ethylene Glycol base*
	EXTENDED LIFE OAT COOLANT/ANTIFREEZE

* OT extended life coolant to be used only after cooling system is completely drained and flushed.
Tractor originally has ethylene glycol type coolant installed.

Capacities

The following chart lists the fluid capacities of the tractor.

Engine oil	5.5 L (5.8 US qt)
Engine coolant	7 L (7.5 US qt)
Transmission / Hydraulic Oil	32.0 L (8.5 US gal)
Front axle	6.5 L (6.9 US qt)
Fuel tank	28.0 L (7.4 US gal)

Maintenance planning

Maintenance chart

Maintenance action	Bleed					Grease					Page no.
	Check	Change fluid	Replace	Tighten	Bleed	Adjust	Cleaning	Drain fluid	Test		
										Bleed	
		Bleed	Grease								
Every 10 hours or daily											
Engine oil level - Check	x										7-12
Engine cooling system - Check	x										7-14
After first 50 hours											
Engine oil and oil filter - Change		x									7-15
Hydraulic oil filter - Replace			x								7-17
Hydrostatic transmission oil filter - Replace			x								7-18
Roll Over Protective Structure (ROPS) - Check	x										7-19
Wheels - Bolts and Nuts - Tighten				x							7-20
Fuel water separator filter - Replace					x						7-21
Every 50 hours											
Grease fittings - Lubricate						x					7-22
Transmission fluid level - Check	x										7-24
Clutch pedal free play - Adjust							x				7-25
Brake pedal free play - Adjust							x				7-26
Hydrostatic Transmission (HST) neutral position - Check and Adjust							x				7-27
Tire inflation pressure - Check	x										7-30
Front axle and differential oil level - Check	x										7-32
Air cleaner - Clean - Primary element							x				7-33
Every 100 hours											
Fuel filter - Drain								x			7-34
Every 300 hours											
Engine oil and oil filter - Change		x									7-34
Oil filter - Replace			x								7-35
Hydrostatic Transmission (HST) oil filter - Replace - HST system			x								7-36
Wheel bolts and nuts - Check				x							7-37
Air cleaner primary element - Replace			x								7-38
Every 500 hours											
Fuel filter water separator - Replace			x								7-39
Every 600 hours											
Front axle and differential fluid - Change		x									7-42
Transmission fluid - Change		x									7-44
Every 1000 hours											
Air cleaner inner element - Replace			x								7-45
Every 1500 hours											
Engine coolant - Draining and flushing								x			7-45
General maintenance											
Hydrostatic transmission (HST) neutral adjustment - Check							x				7-46
Roll Over Protective Structure (ROPS) - Replace - Possible damage			x								7-48
Battery									x		7-49
Alternator	x										7-50
Headlight bulb - Replace			x								7-51

Maintenance action	Bleed				Grease				Page no.
	Tighten				Adjust				
	Replace				Cleaning				
	Change fluid				Drain fluid				
	Check				Test				
Turn signal/Hazard light bulb replacement			X						7-52
Flasher unit bulb - Replace			X						7-53
Wheels - Bolts and Nuts - Tighten				X					7-55
Front wheel toe-in - Adjust					X				7-56
Brake pedal free play - Adjust					X				7-57
Clutch pedal free play - Adjust					X				7-58

Every 10 hours or daily

Engine oil level - Check

⚠ WARNING
Burn hazard!
 Allow the oil to cool down below 49 °C (120 °F) before checking.
 Failure to comply could result in death or serious injury.

W1127A

NOTE: Check the engine oil level daily or after every 10 hours of operation.

1. After the engine has been stopped for a period of time and with the tractor standing level, check the oil level using the dipstick (1).

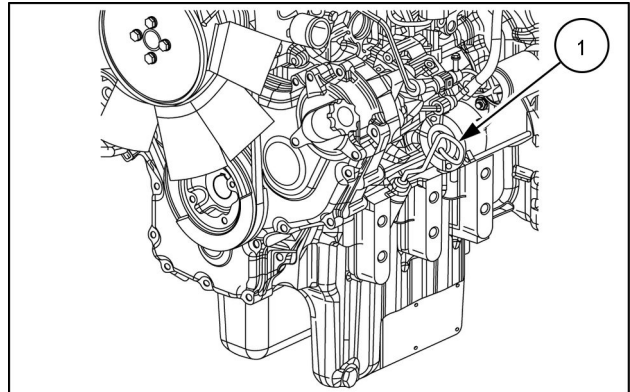

NHIL16CT00449AA 1

2. If the oil level is low, remove the filler cap (2) add oil through the filler hole.

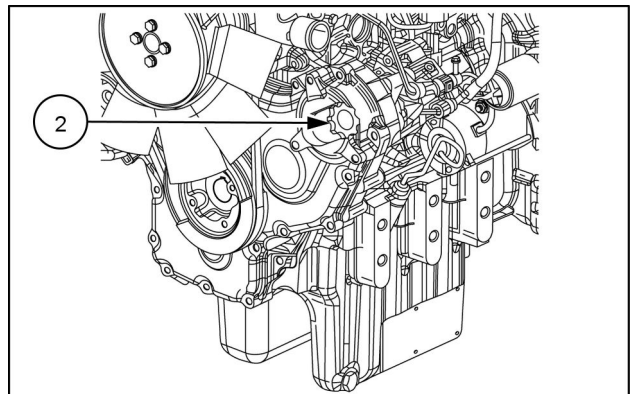

NHIL16CT00449AA 2

3. Add enough oil so that the level registers between the **(L)** low and the **(H)** high marks on the dipstick. Do not overfill.

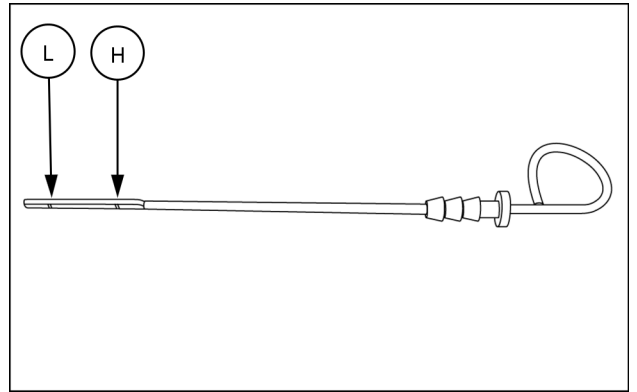

93100903 3

Engine cooling system - Check

Cooling system

The tractor engine must operate at the correct temperature to obtain maximum efficiency and service life. This is dependent on the cooling system.

Always fill the system with a 50/50 solution of ethylene glycol antifreeze and water.

Checking the coolant level

▲ WARNING

Burn hazard!

Hot coolant can spray and scald if you remove the radiator or deaeration tank cap while the system is hot. To remove the cap: allow the system to cool, turn the cap to the first notch, and wait for all pressure to release. Remove the cap only after all pressure has released. Failure to comply could result in death or serious injury.

W0367A

NOTE: Check the coolant level daily or after every 10 hours of operation. The engine should be cold when coolant level is checked.

1. Visually inspect the coolant level in the coolant recovery reservoir (1) the coolant level should be between the "LOW" and "HIGH" lines located on the side of the reservoir.
2. If the coolant level is not between the "LOW" and "HIGH" lines, add a water/antifreeze solution as necessary. The cooling system already contains antifreeze, add only antifreeze solution of the correct water/antifreeze mixture. Pure water will dilute the solution and weaken its protection.
3. Keep the radiator fins clear of chaff or dirt to allow free air movement.
4. Check and clean front radiator screen (2) every 10 hours of operation.

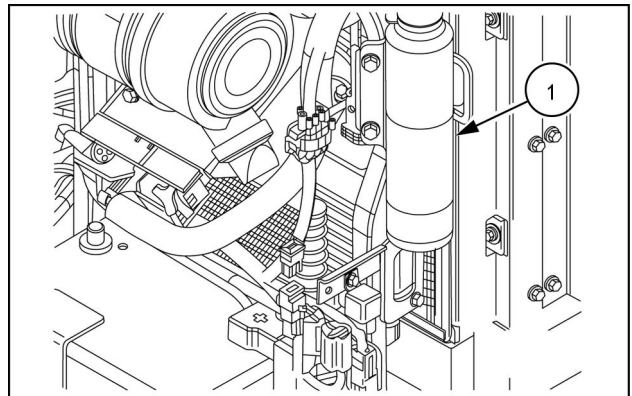

NHIL16CT00474AA 1

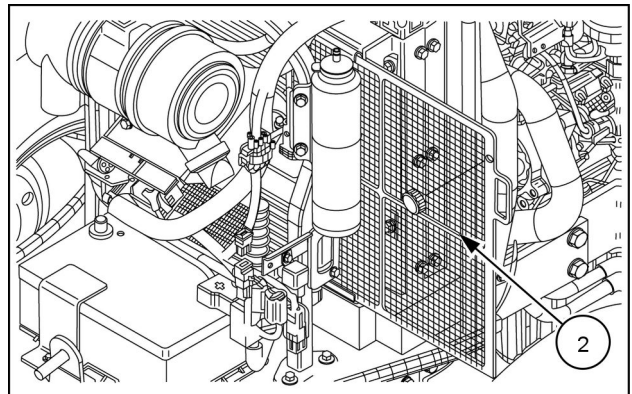

NHIL16CT00448AA 2

After first 50 hours

Engine oil and oil filter - Change

⚠ WARNING

Jack stands can slip or fall over. Dropping, tipping, or slipping of machine or its components is possible.

DO NOT work under a vehicle supported by jack stands only. Park machine on a level surface. Block wheels. Support machine with safety stands.

Failure to comply could result in death or serious injury.

W0069A

⚠ WARNING

Burn hazard!

Do not handle any service fluid (engine coolant, engine oil, hydraulic oil, etc.) at temperatures that exceed 49 °C (120 °F). Allow fluids to cool before proceeding.

Failure to comply could result in death or serious injury.

W0330B

NOTE: Change the engine oil and filter after the first 50 hours of operation, then every 300 hours thereafter.

To change the engine oil, do the following:

1. Place a suitable container beneath the drain opening to catch the used oil. With the tractor engine off but at normal operating temperature, remove the two drain plugs, (1) and (2), located on both sides of the engine oil pan. Install the plugs after draining the oil.

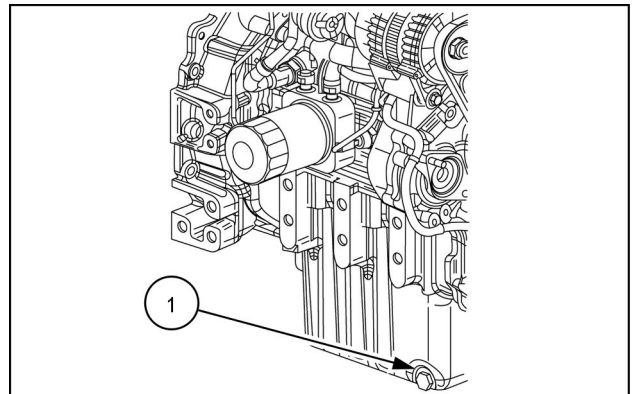

NHIL16CT00447AA 1

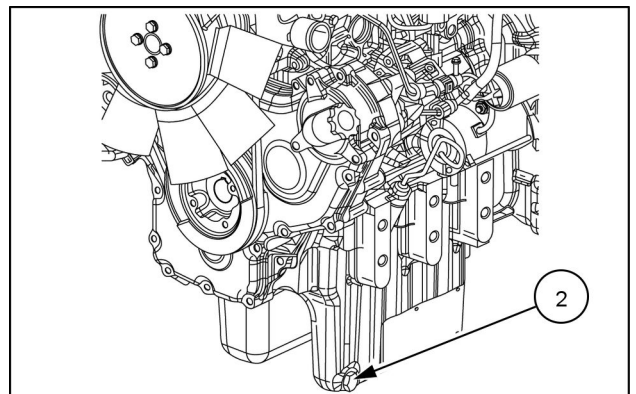

NHIL16CT00449AA 2

2. Next, place a container below the oil filter, **(3)**, to catch the used oil and unscrew the oil filter. Discard the used oil and filter.
3. Coat the gasket on the new filter with a film of clean oil. Screw the filter into place until the gasket contacts the mating surface, and then turn the filter approximately three-quarters of a turn by hand. Do not overtighten.

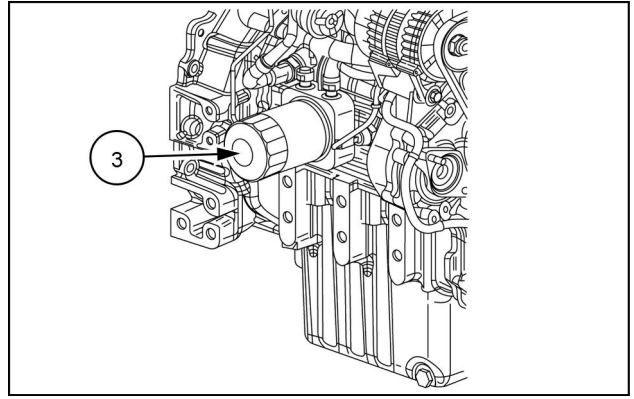

NHIL16CT00447AA 3

4. Add the specified type and amount of new oil at fill port **(4)**, then start the engine and check the filter for leaks.

NOTE: Oil Capacity, with filter see **7-10**

NOTICE: Use of any engine oil other than (CJ-4) may clog the (DPF) earlier than expected and fuel usage may increase.

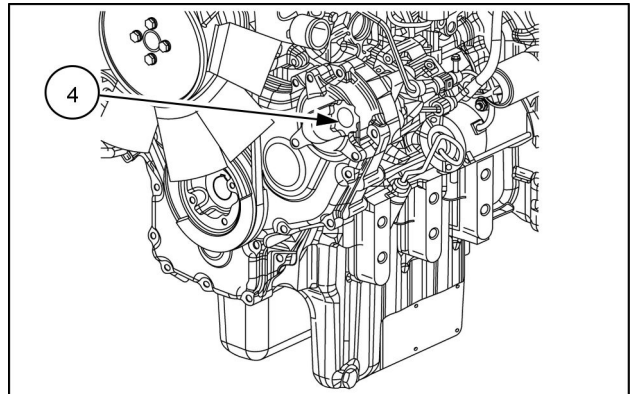

NHIL16CT00449AA 4

Recommended Oils

For machines with Tier 4B (final) engines

	(H)	0W-40 CJ-4 UNITEK																		
	(H)	0W-40 API CJ-4*																		
-40 °C	-30 °C	-20 °C	-10 °C	0 °C	10 °C	20 °C	30 °C	40 °C	50 °C											
-40 °F	-22 °F	-4 °F	14 °F	32 °F	50 °F	68 °F	86 °F	104 °F	122 °F											

(H) NEW HOLLAND recommends the use of an engine oil pan heater or coolant block heater in this range.
 * Requires a **50%** reduction in engine oil service change interval

Hydraulic oil filter - Replace

NOTE: Replace the hydraulic system oil filter after the first 50 hours of operation, and then following every 300 hours of operation thereafter.

The hydraulic system uses a spin-on type oil filter **(1)**, located on the right-hand side of the tractor underneath the operator's platform. To replace the filter :

1. Unscrew the used oil filter and discard.
2. Coat the gasket on the new filter with a film of clean oil. Screw the filter into place until the gasket contacts the sealing surface, then tighten the filter by hand approximately three-quarters of a turn. Do not overtighten.
3. Start the engine and check the filter for leaks.
4. Stop the engine and check the hydraulic system oil level. Add oil if necessary.

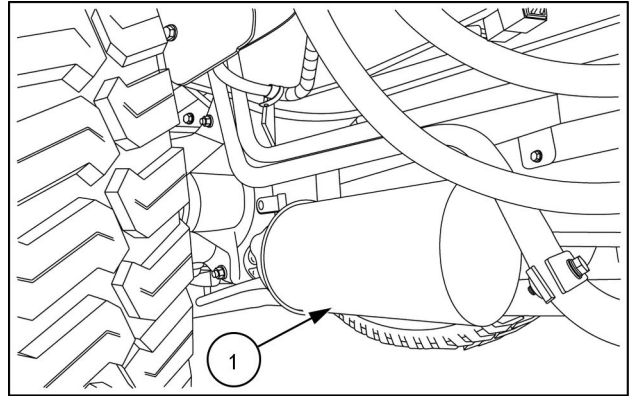

NHIL13CT01017AA 1

Hydrostatic transmission oil filter - Replace

NOTE: Change the hydrostatic (HST) system oil filter after the first 50 hours of operation, and then following every 300 hours of operation thereafter.

The hydrostatic system uses a spin-on type oil filter **(1)**, located on the left-hand side of the tractor underneath the operator's platform.

To replace the filter:

1. Unscrew the used oil filter and discard.
2. Coat the gasket on the new filter with a film of clean oil. Screw the filter into place until the gasket contacts the sealing surface, then tighten the filter by hand approximately three-quarters of a turn. Do not overtighten.
3. Start the engine and check the filter for leaks.
4. Stop the engine and check the hydraulic system oil level. Add oil if necessary.

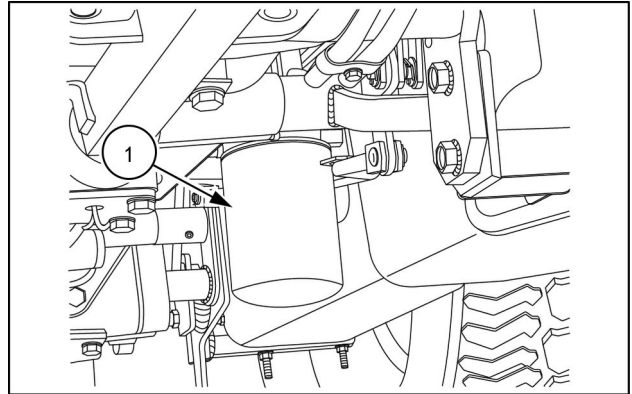

NHIL13CT01245AA 1

Roll Over Protective Structure (ROPS) - Check

Maintenance and inspection

NOTE: Inspect the Roll Over Protection Structure - ROPS after the first 50 hours of operation. Following the initial inspection, the ROPS should be checked after every 300 hours of operation or every six months, whichever comes first.

1. Check the torque of the ROPS bottom portion mounting bolts, (1). Tighten the M14, bolts to the correct torque of **147 N·m (108 lb ft)** if necessary.
2. Check the torque of the ROPS cross brace mounting bolts (2). Tighten the M10 bolts to the correct torque of **60 N·m (41 lb ft)**. if necessary.
3. Check the torque of the ROPS top portion mounting bolts (3). Tighten the M12, bolts to the correct torque of **83 N·m (61 lb ft)** if necessary.
4. Inspect the operator's seat and the mounting parts for the seat belt. Tighten the bolts (4) to the correct torque of **28 N·m (21 lb ft)** if necessary and replace any parts that show wear or damage.

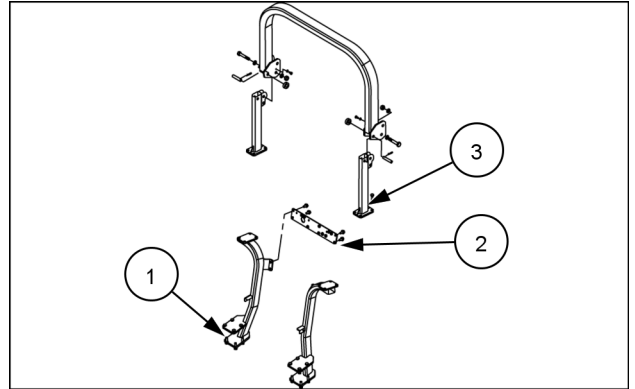

230100876 1

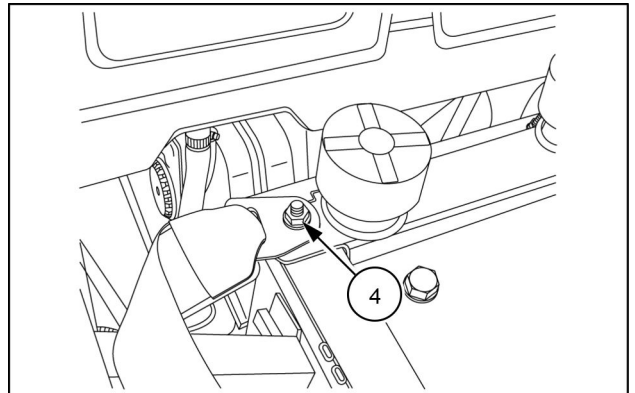

NHIL12CT00838AA 2

Wheels - Bolts and Nuts - Tighten

Tighten the wheel bolts (1) and nuts (2) to the specified torque any time the wheel assembly is removed from the tractor or the wheel bolts are loosened.

Front Wheel Torque

- 176 – 196 N·m (130 – 145 lb ft)

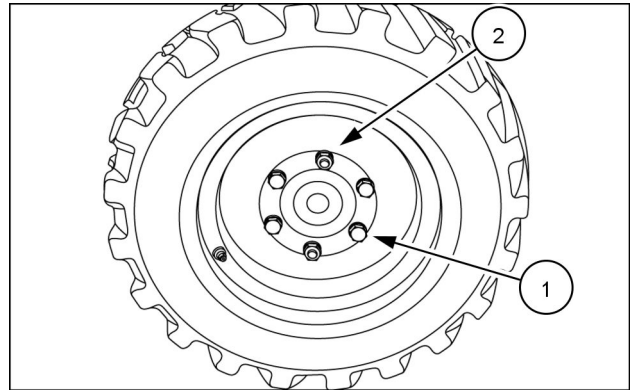

93100874 1

Rear Wheel Torque

- 176 – 196 N·m (130 – 145 lb ft)

NOTICE: Check and tighten wheel bolts (1) and nuts (2) to proper torque specifications after the following hours of use:

- First 5 hours
- First 50 hours
- Every 300 hours

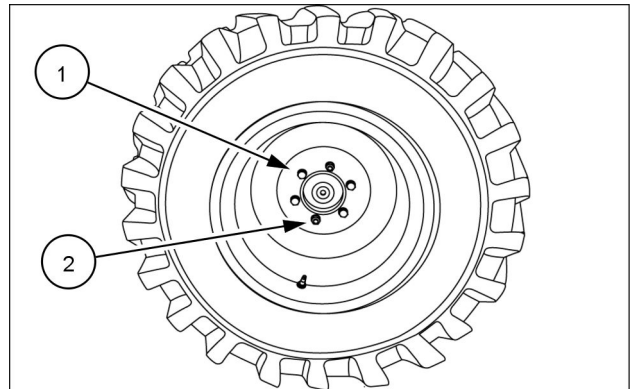

93100875A 2

Fuel water seperator filter - Replace

See 7-39.

Every 50 hours

Grease fittings - Lubricate

NOTE: After every 50 hours of normal operation, apply a good quality grease to the lubrication points listed below. When operating under extremely dirty conditions, lubricate more frequently than every 50 hours.

- 1. Front Axle Pivot (1)

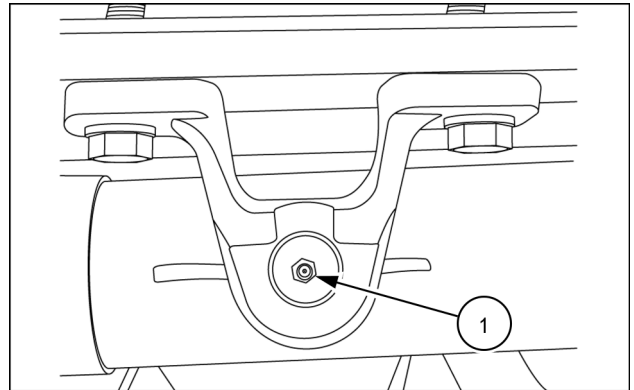

93100890 1

- 2. Power Steering Cylinder (2)

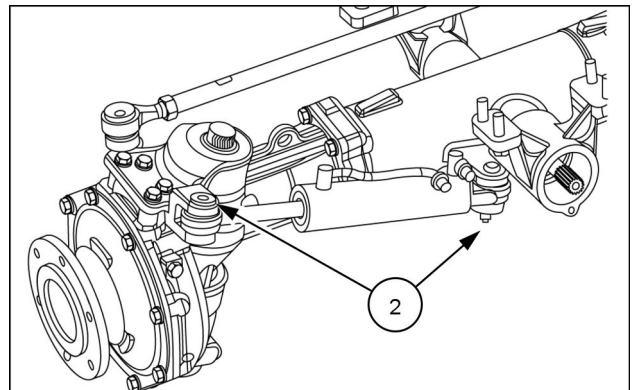

93100864 2

- 3. Clutch Pedal Shaft (3) (Mechanical tractor)

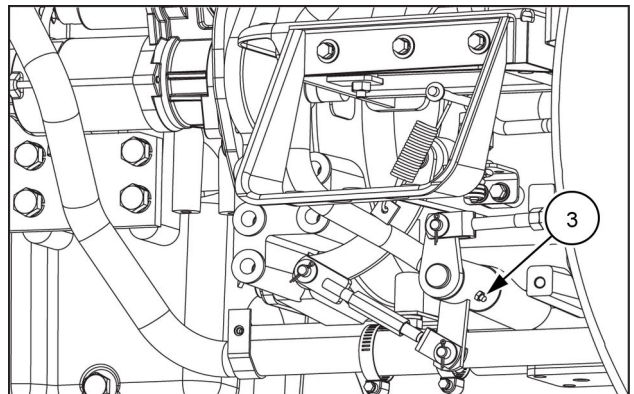

NHIL13CT00158AA 3

4. Brake pedals shaft **(4)** (Mechanical tractor).

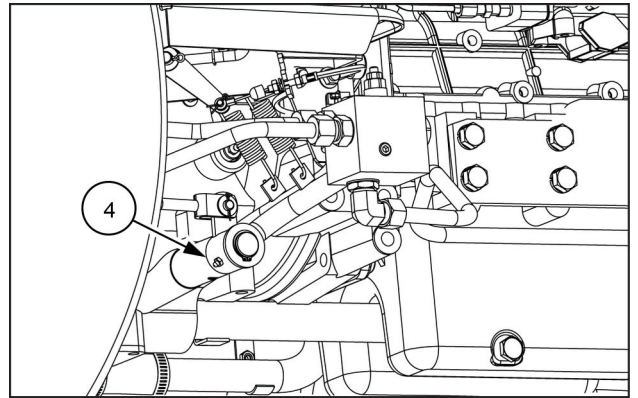

NHIL13CT00157AA 4

5. Brake pedals shaft **(5)** (HST tractor).

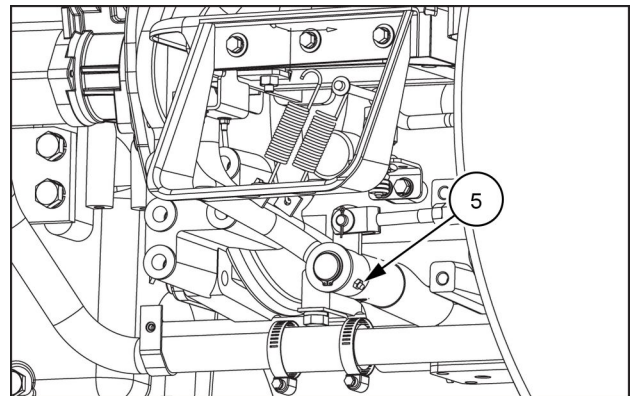

NHIL13CT00159AA 5

6. 3-Point Linkage **(6)** oil threads

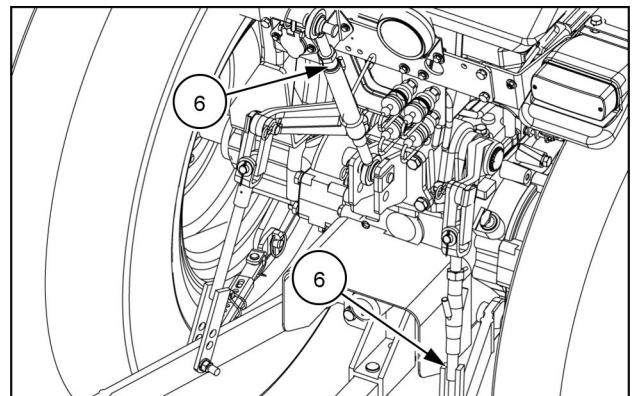

NHIL12CT00821AA 6

To lubricate these points:

7. Wipe away all old grease and dirt from the lubrication fittings to prevent dirt or foreign material from entering as new grease is applied.
8. Use a grease gun to pump in the new grease. Apply pressure until clean grease oozes from each lubrication point.
9. Wipe away any excess grease.

Transmission fluid level - Check

NOTE: Check the transmission, rear axle, and hydraulic system oil level after every 50 hours of operation.

1. With the engine off and the tractor standing level, check the oil level using the dipstick (1).

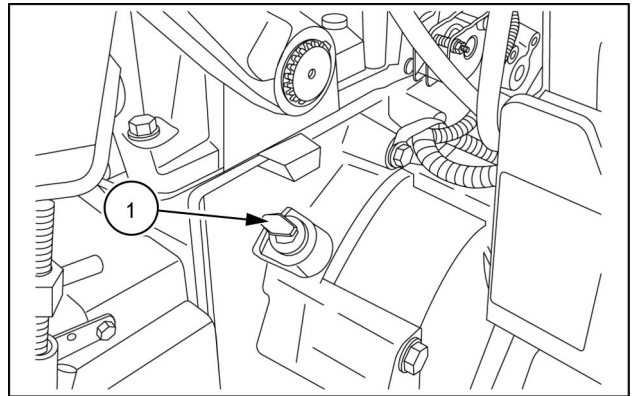

NHIL12CT00684AA 1

2. The oil is at the correct level when it reads between the two marks (A) on the dipstick. If the level is low, add **HYDRAULIC TRANSMISSION OIL - PREMIUM** hydraulic oil through the dipstick hole. Do not fill above the dipstick full mark.
3. Reinstall the dipstick.

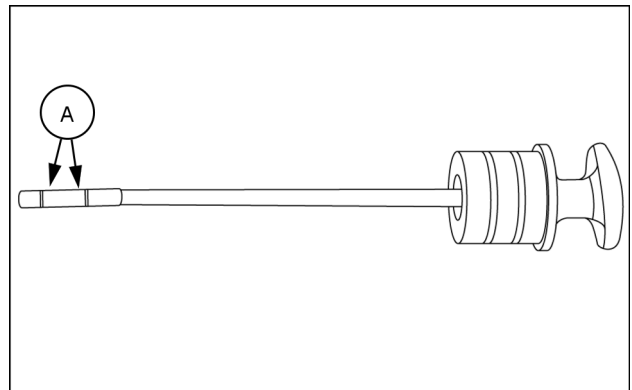

93100904 2

Clutch pedal free play - Adjust

NOTE: Check clutch pedal free travel after every 50 hours of operation.

Clutch pedal free travel should be maintained at A = **20 – 30 mm (0.79 – 1.18 in)**.

To adjust the clutch pedal:

1. Loosen lock nut **(1)** and rotate adjuster **(2)**
2. Tightening the adjuster will decrease the free play travel and loosening the adjuster will increase the free play travel.
3. Tighten the lock nut when the correct free play travel is obtained
4. Check clutch for disengagement when clutch pedal is fully depressed.

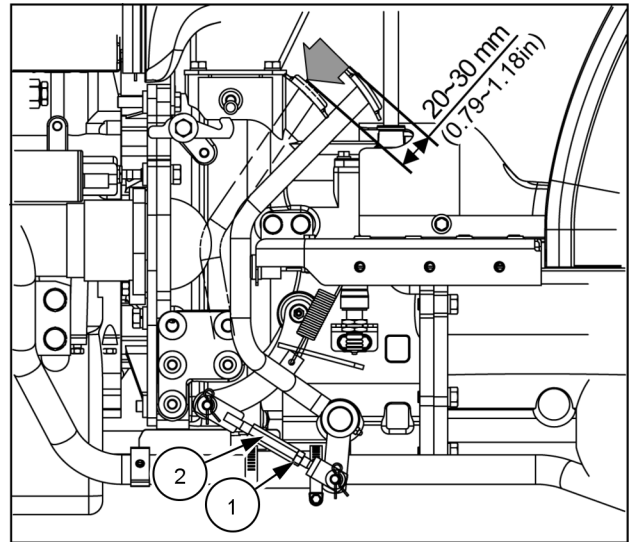

NHIL12CT00783AA 1

Brake pedal free play - Adjust

Whenever brake pedal travel becomes excessive, or if the travel of one pedal is unequal to that of the other, each pedal should be adjusted.

1. Loosen the locknut (1) and rotate the brake rod (2) until there is (A) = 50 – 60 mm (1.97 – 2.36 in) of pedal free play. Lengthening the rod increases free play. Shortening the rod decreases free play.

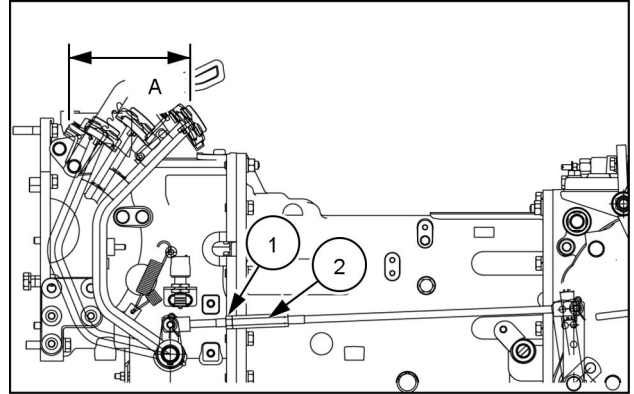

NHAC13CT00055AA 1

2. Test drive the tractor to make sure the braking action of both rear wheels is equal. Readjust as necessary.

NOTE: Note HST tractor is in Figure 1 and Mechanical tractor is in Figure 2.

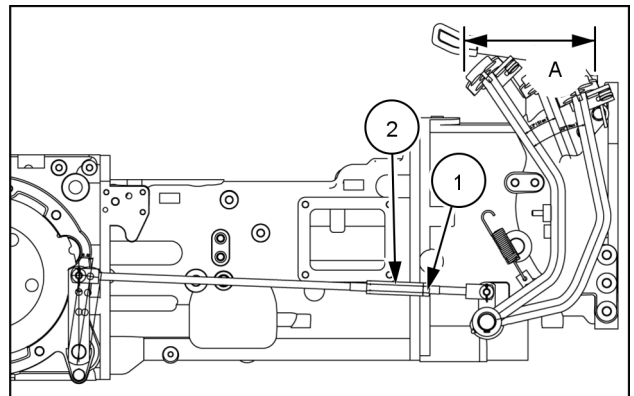

NHAC13CT00139AA 2

Hydrostatic Transmission (HST) neutral position - Check and Adjust

Checking Hydrostatic Transmission (HST) return to "NEUTRAL"

1. Place range gear lever (A) in "LOW" range and engine speed at high idle position.

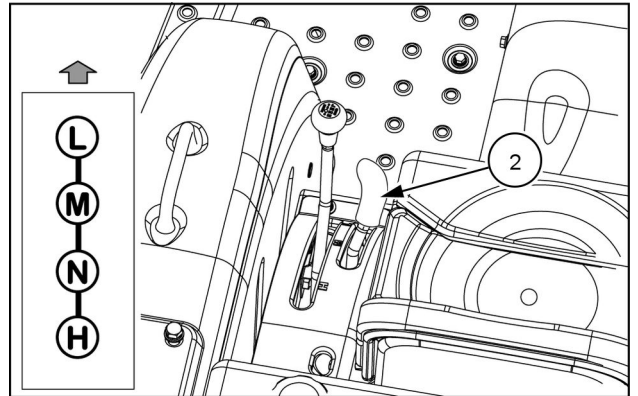

NHIL12CT01098AA 1

2. Drive tractor in forward and reverse, remove foot from HST pedal. Tractor should stop and rear wheels should not rotate when pedals are at "NEUTRAL" position.
3. If rear wheels rotate when HST pedals are in the "NEUTRAL" position, the HST control linkage needs to be adjusted.

Adjusting "NEUTRAL" setting of Hydrostatic Transmission (HST) control linkage

1. Park the tractor on level hard surface, with the engine turned off.

NOTICE: Before raising the rear wheels, install chocks between the front axle and engine frame to prevent the front of the tractor from oscillating side to side.

2. Raise the rear tires off the ground and support axles, with safety stands.
3. Place the 4WD control lever (**2**) in the "2WD" position.

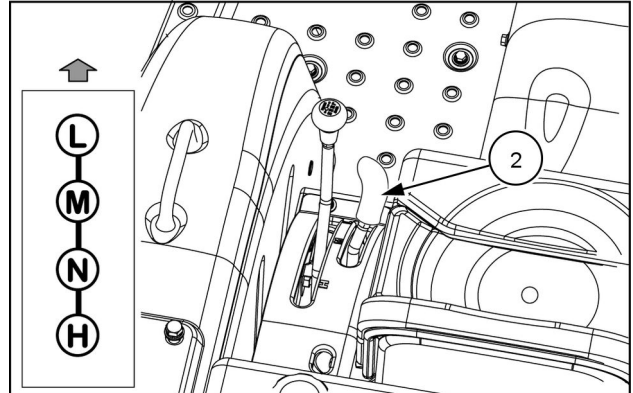

NHIL12CT01098AA 2

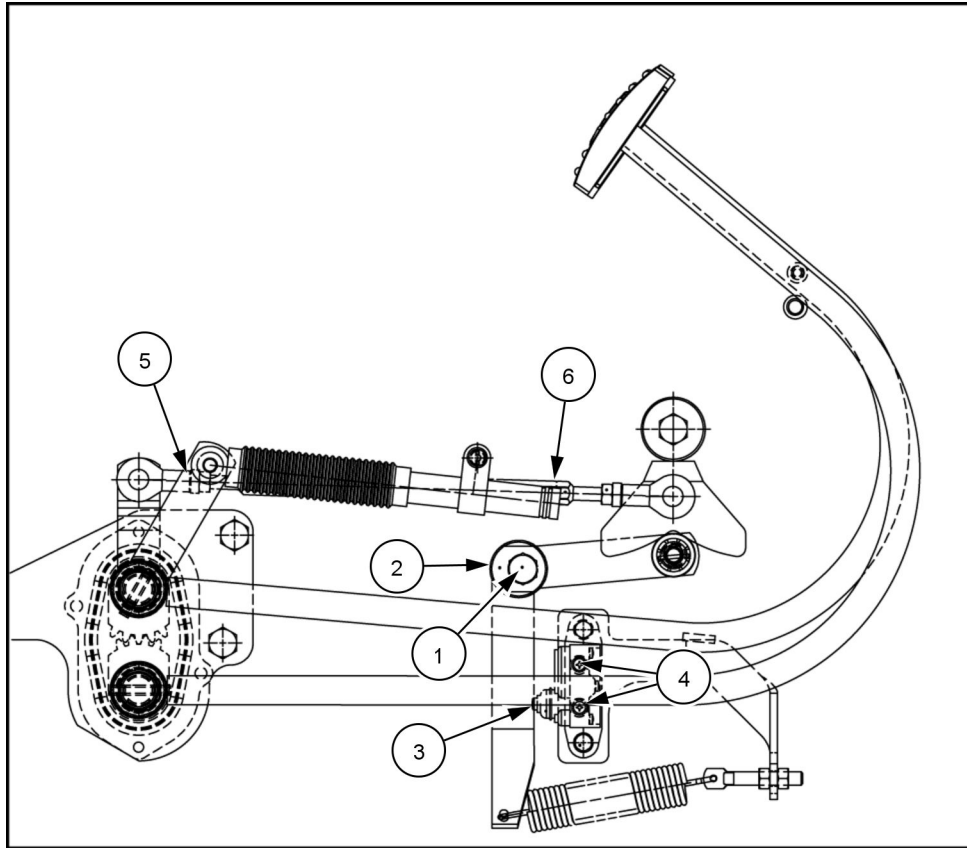

NHIL12CT00784AA 3

4. The forward and reverse pedals should be at the same height. Adjust pedal height by loosening bolt **(1)** and rotating shaft **(2)** as needed. After height adjustment is obtained, hold shaft **(2)** in place when tightening bolt **(1)**.
5. After pedal height adjustment is completed, check that HST neutral switch **(3)** is depressed when the pedals are in the "NEUTRAL" position. If switch is not depressed, loosen bolts **(4)** and adjust position of switch so that switch is depressed. Tighten bolts after adjustment is completed.
6. Start the tractor, place the range gear in "LOW" range and engine speed at high idle.
7. Depress both forward and reverse pedals separately. Release pedals and check if rear wheels rotate when pedals return to the "NEUTRAL" position.
8. If rear wheels rotate when pedals are at the "NEUTRAL" position, adjust HST linkage by loosening jam nuts **(5)** and rotating rod **(6)** until wheels do not rotate. Tighten jam nuts after adjustment is completed.
9. Remove tractor from safety stands, when adjustment is completed.

Tire inflation pressure - Check

NOTE: Check tire pressure after every 50 hours of operation or weekly.

Tire inflation pressure affects the amount of weight a tire can carry. Check the air pressure in your tractor tires, then locate the tires in the **9-1** chart found in this manual. If necessary, adjust the tire pressure, being careful not to overinflate or under inflate. Observe the following guidelines:

⚠ WARNING

Explosion hazard!

A tire can explode during inflation. Properly seat the tire before inflating. Never increase air pressure beyond 240 kPa (35 psi) to seat the bead on the wheel rim. Never use force on a partially or fully inflated tire. Do not exceed the inflation pressure recommended by the tire manufacturer.

Failure to comply could result in death or serious injury.

W0456A

- Do not inflate a tire above the maximum pressure shown on the tire. If the tire is not marked, do not exceed the maximum pressure shown in the Tire Inflation chart found in this manual.
- Do not reinflate a tire that has been run flat or seriously under inflated until the tire has been inspected for damage by a qualified person.
- When checking tire pressure, inspect the tire for damaged sidewalls and tread cuts. Neglected damage leads to early tire failure.

If you must inflate or service tires, follow these safety precautions to avoid injury or fatality:

- Make sure the rim is clean and free of rust.
- Lubricate both tire beads and rim flanges with soap solution. Do not use oil or grease.
- Use a clip-on tire chuck with a remote hose and gauge. This allows the operator to stand clear of the tire while inflating.
- NEVER INFLATE TO OVER **241 kPa (35 psi)** TO SEAT BEADS. If beads have not been seated by the time pressure reaches **241 kPa (35 psi)**, deflate the assembly, reposition the tire on the rim, relubricate both tire bead and rim flanges, and reinflate. Inflation beyond **241 kPa (35 psi)** with unseated beads may break the bead or rim with explosive force sufficient enough to cause serious injury.
- After seating the beads, adjust inflation pressure to recommended operating pressure.
- Do not inflate a tire unless the rim is mounted on the tractor or is secured so that it will not move if the tire or rim should suddenly fail.
- Do not weld, braze, otherwise repair, or use a damaged rim.
- Never attempt tire repairs on a public road or highway
- Use jack stands or other suitable blocking to support the tractor while repairing tires.
- Ensure jack has adequate capacity to lift your tractor.
- Place jack on a firm, level surface.
- Do not place any part of your body beneath the tractor or start the engine while the tractor is on the jack.
- Before adding ballast to the tires, refer to **6-2**, **6-2**, **6-4**, and **9-2**.

Front axle and differential oil level - Check

NOTE: Check the front axle differential case and final reduction gear case oil level after every 50 hours of operation.

1. With the tractor standing level and the engine off, check the front axle oil level using the dipstick (1), located on the left side of axle.

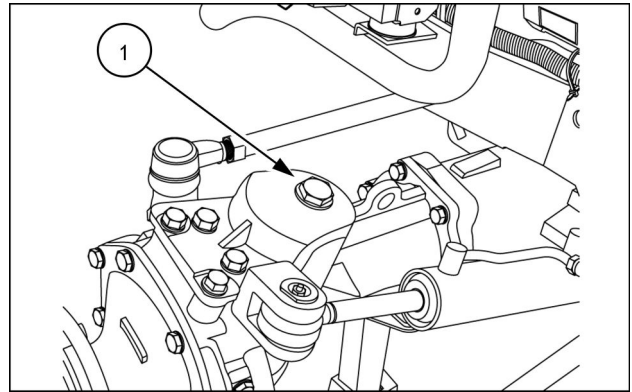

93100889 1

2. The oil is at the correct level when it reads between the upper (A) and the lower (B) marks of the dipstick.
3. If capacity is low, add **HYPOID GEAR OIL EP SAE 80W-90** oil through the combined dipstick/filler plug. Do not fill beyond the dipstick full mark, or the front axle and differential housing will be overfilled.
4. Install the dipstick/filler plug.

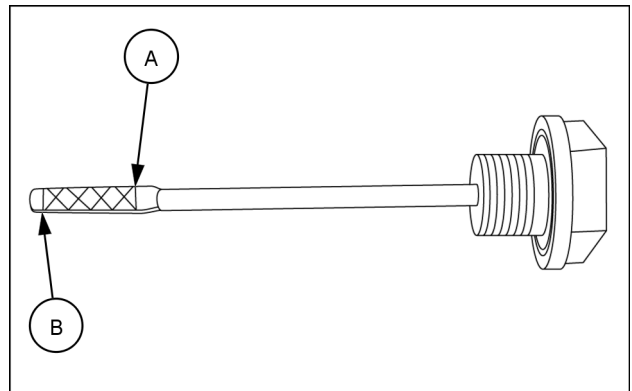

93100902 2

Air cleaner - Clean - Primary element

⚠ WARNING

Rotating parts!
Do not start the engine while you perform this procedure.
Failure to comply could result in death or serious injury.

W1374A

NOTE: Clean the primary element after every 50 hours of service. Extremely dusty conditions may require more frequent service intervals.

1. Pull the primary element (1) from the canister. Clean any loose dirt from the canister and inspect the end of the canister for dirt, which may prevent the new element from sealing properly.
2. Clean the primary element using low air pressure (**2 Kg/cm² (30 psi)** or less). Blow dust from the inside to the outside of the element (opposite to normal airflow through element).

NOTICE: Be careful not to rupture the filter element. Maintain a safe distance between the air nozzle and the filter element when directing air up and down the clean airside of the element pleats.

3. After cleaning the element, check the inner diameter seals for damage. If damage is present, replace the primary element.
4. Install the primary element by inserting it into the canister and pushing on the end of the element until it seats against the canister.

NOTE: Place a light inside the element to check for holes in the paper element or for bonding issues of the paper to the end plate. If you find leaks, replace the element.

NOTE: If element is not inserted far enough into canister, the end cap cannot be installed.

5. Place the end cap onto the canister body, push in on end cap, and rotate clockwise. Make sure the end cap locks in place and is not loose.

NOTICE: Never tap the element with hard objects or against a hard surface. This action will damage the element end cap seals.

NOTICE: Failure to obtain a good seal between elements and the canister may cause major engine damage.

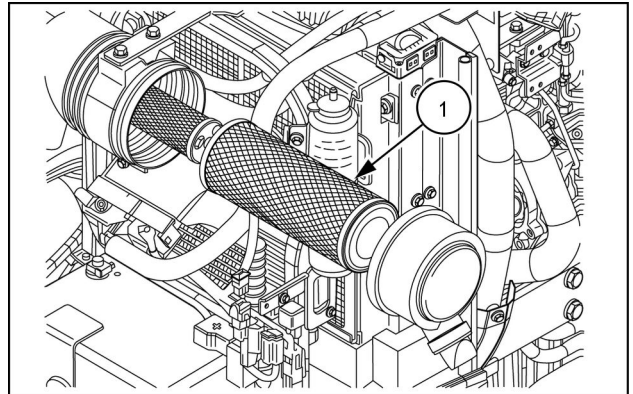

NHIL16CT00464AA 1

Every 100 hours

Fuel filter - Drain

▲ WARNING

Pressurized system!

Only use the bleed screw to bleed air from the fuel system. DO NOT loosen the fuel or injector lines to bleed air. Injury or damage can occur. Fuel or injector lines are under very high pressure. Failure to comply could result in death or serious injury.

W0285A

NOTE: Drain the fuel filter (1) after every 100 hours of operation or whenever the water in fuel light is illuminated on the instrument panel. See **Instrument panel** item (8) for Fuel Filter Warning Indicator Light location and operation.

1. Place a suitable container below the fuel water separator filter (1).
2. Disconnect the water in fuel sensor wiring harness connector (2).

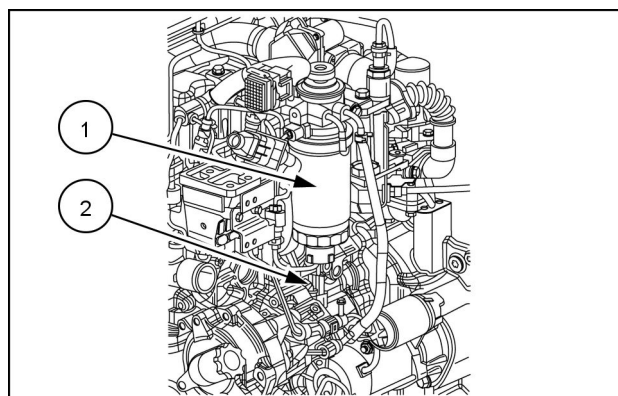

NHIL16CT00461AA 1

3. Loosen the water in fuel sensor nut (3) and drain the water from inside the fuel water separator filter.
4. Tighten the nut when only fuel flows from the drain hole.

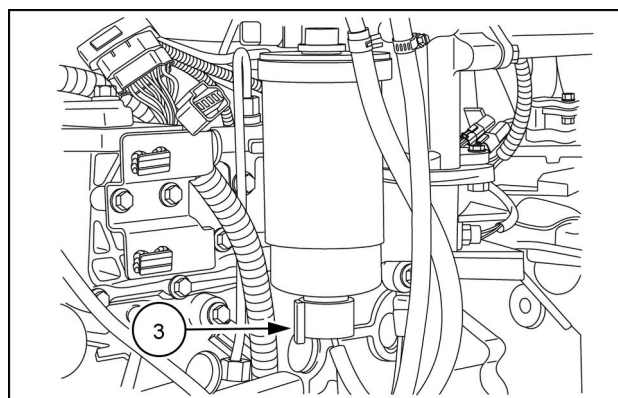

NHIL16CT00485AA 2

Next operation:

Bleed the fuel system. See **Fuel water separator filter - Bleed**

Every 300 hours

Engine oil and oil filter - Change

See 7-15

Oil filter - Replace

See 7-17

Hydrostatic Transmission (HST) oil filter - Replace - HST system

See 7-18.

Wheel bolts and nuts - Check

See 7-20.

Air cleaner primary element - Replace

⚠ WARNING

Rotating parts!
Do not start the engine while you perform this procedure.
Failure to comply could result in death or serious injury.

W1374A

NOTE: Replace the primary element after every 300 hours of service. Extremely dusty conditions may require more frequent service intervals.

1. Pull the primary element (1) from the canister. Clean any loose dirt from the canister and inspect the end of the canister for dirt, which may prevent the new element from sealing properly.
2. Install the new primary element by inserting it into the canister and pushing on the end of the element until it seats against the canister.

NOTE: If element is not inserted far enough into canister, the end cap cannot be installed.

3. Place the end cap onto the canister body, push in on end cap, and rotate clockwise. Make sure the end cap locks in place and is not loose.

NOTICE: Failure to obtain a good seal between elements and the canister may cause major engine damage.

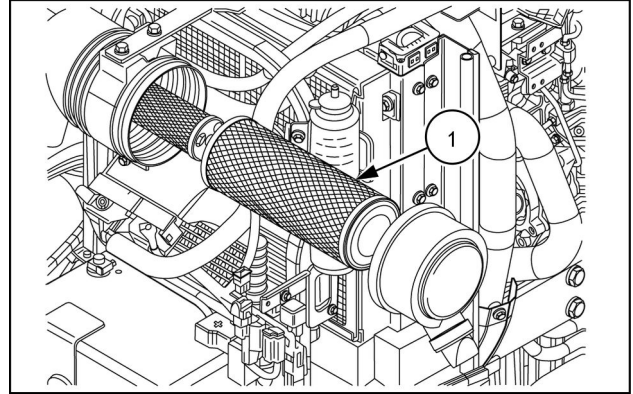

NHIL16CT00464AA 1

Every 500 hours

Fuel filter water separator - Replace

⚠ WARNING

Fuel vapors are explosive and flammable.
 Do not smoke while handling fuel. Keep fuel away from flames or sparks. Shut off engine and remove key before servicing. Always work in a well-ventilated area. Clean up spilled fuel immediately.
 Failure to comply could result in death or serious injury.

W0904A

Removal

NOTE: Change the fuel water separator filter after the first 50 hours of operation, then after every 500 hours of operation.

1. Disconnect the water in fuel sensor wiring harness (1).

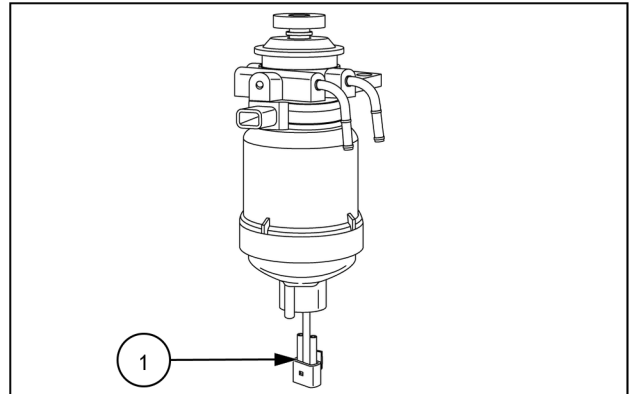

NHIL22CT00422AA 1

2. Place a suitable container below the fuel water separator filter drain.
3. Remove the fuel filter sensor (1) and allow fuel to drain.

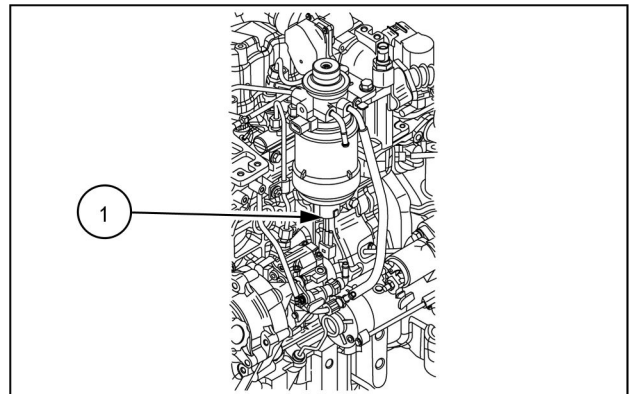

NHIL22CT00432AA 2

4. Turn the housing (1) counter-clockwise to remove the filter assembly from the filter flange (2).

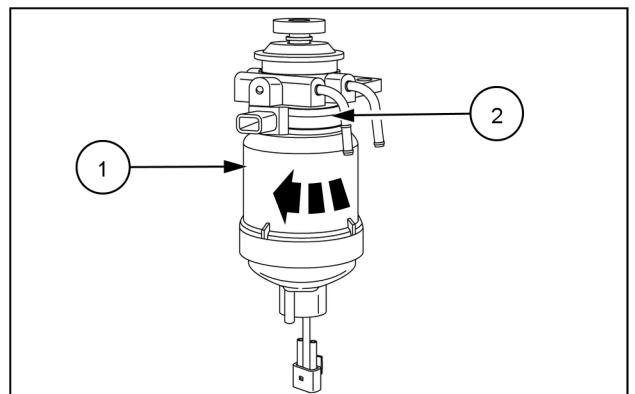

NHIL22CT00422AA 3

5. Unscrew the canister bottom (1) from the filter housing (2), and then remove the filter (3).

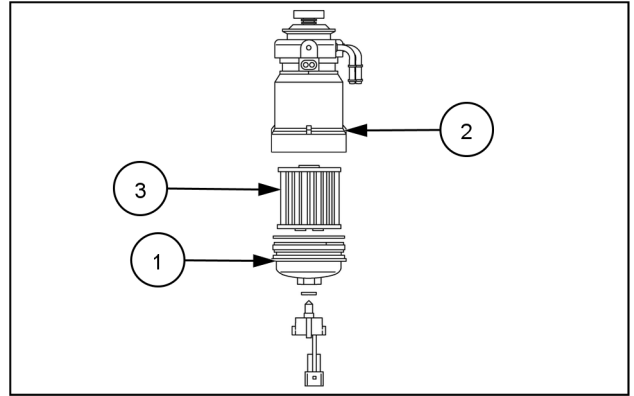

NHIL22CT00423AA 4

Installation

NOTICE: During assembly replace the filter (1), the gasket (2), and the O-ring (3).

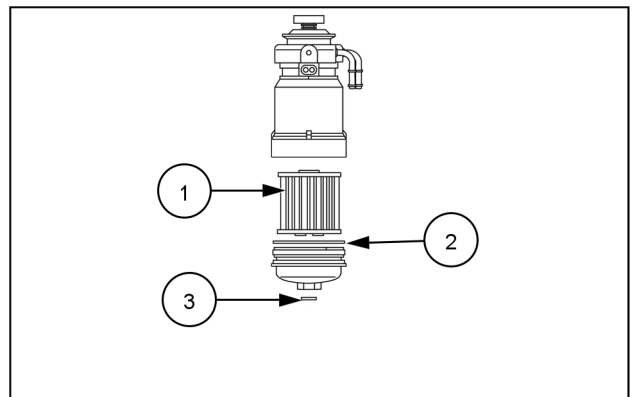

NHIL22CT00423AA 5

1. Apply clean diesel fuel to the gasket (1) that is between the canister bottom (2) and the filter housing (3).

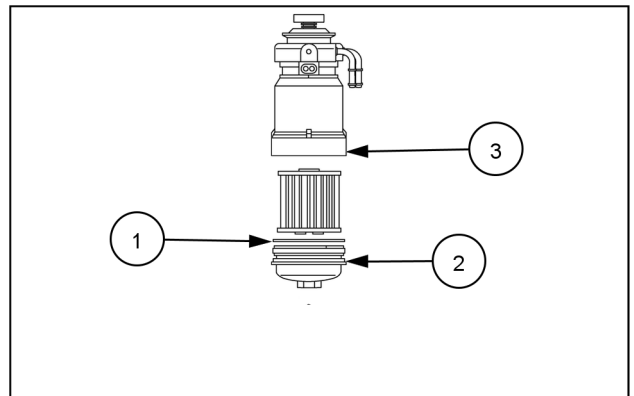

NHIL22CT00423AA 6

2. Install the filter element (1) into the filter housing (2), place the gasket (3) onto the canister bottom (4).

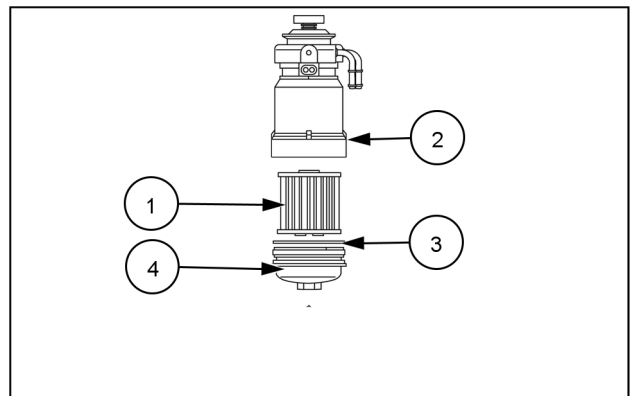

NHIL22CT00423AA 7

3. Install the canister bottom (4) into the filter housing by turning it in a clockwise direction.

NOTICE: Hand tighten the canister bottom (4).

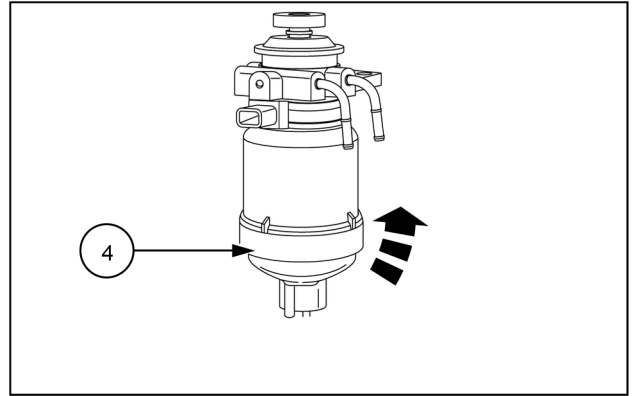

NHIL22CT00422AA 8

4. Replace the O-ring (1) on the water in fuel sensor (2).

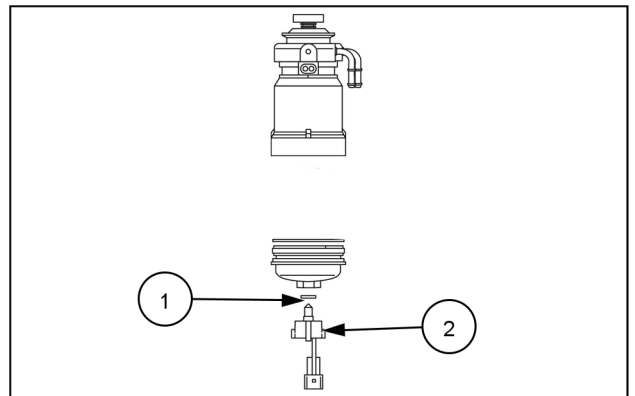

NHIL22CT00423AA 9

5. Screw the water in fuel sensor (1) into the canister bottom (2).

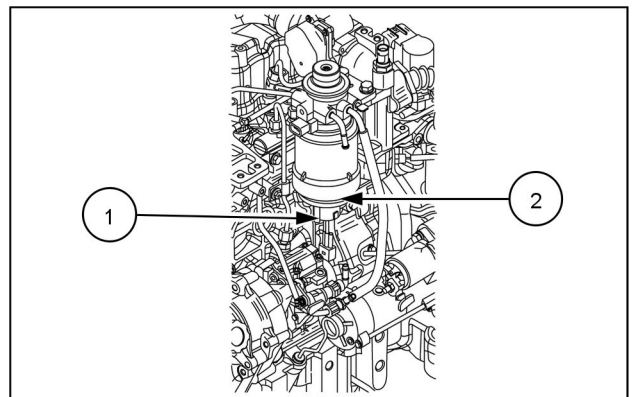

NHIL22CT00432AA 10

6. Connect the water in fuel wiring connector (1).

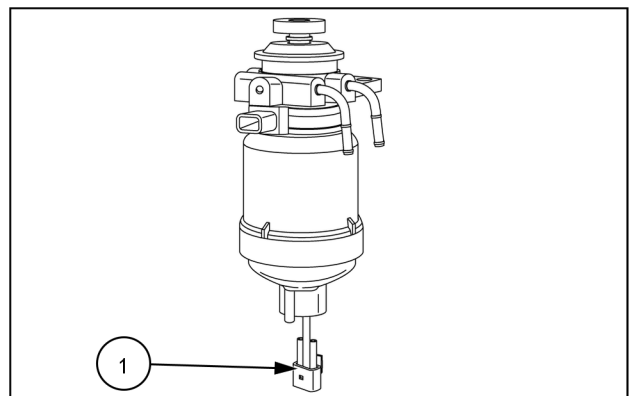

NHIL22CT00422AA 11

NOTE: Perform the bleed process. See **Fuel water separator filter - Bleed**.

Next operation:
Fuel water separator filter - Bleed

Every 600 hours

Front axle and differential fluid - Change

Changing front axle differential and final reduction gear case oil

NOTE: The front axle differential case and final reduction gear case oil should be changed after every 600 operating hours.

1. Place a suitable container beneath the oil plugs. With the oil at normal operating temperature, drain the oil by removing the drain plugs (1) After the oil has drained, reinstall the drain plugs and discard the used oil.

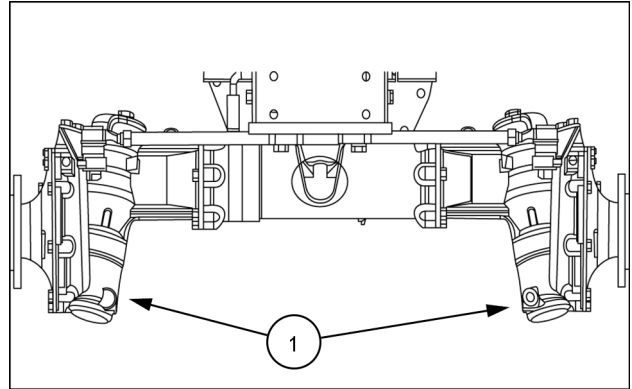

93100868 1

2. Remove the dipstick/filler plug (2)

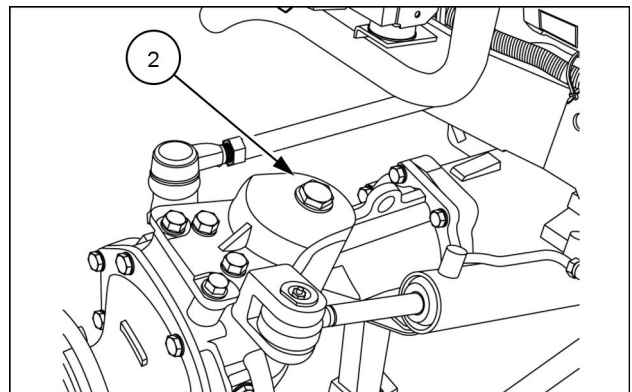

93100889 2

3. Fill the axle with **HYPOID GEAR OIL EP SAE 80W-90** oil until the oil level is between the upper mark (A), and the lower mark (B) of the dipstick. Reinstall the dipstick/filler plug.

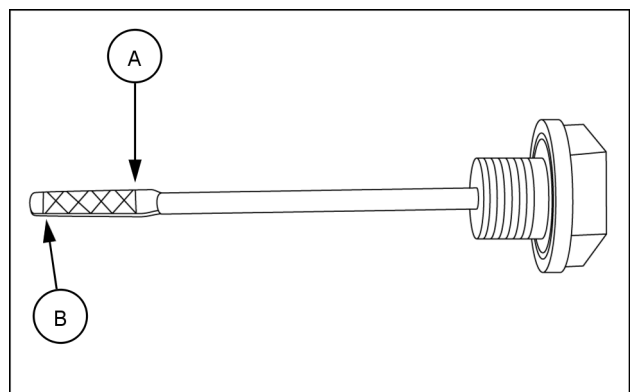

93100902 3

4. Raise the front axle until both wheels are off the ground.
5. Tilt axle until stops are contacted.

6. Slowly and momentarily remove plug **(3)** from the lower side final drive housing. This will allow any air that is trapped in the lower housing to escape, so that the correct oil level can be achieved. Reinstall plug and tilt axle the opposite direction. Repeat this procedure for the other final drive housing.
7. Lower axle back to the ground.
8. Recheck oil level at dipstick, add oil if needed until oil level is between the upper and lower marks of dipstick.
9. After correct oil level is achieved, tighten all plugs.

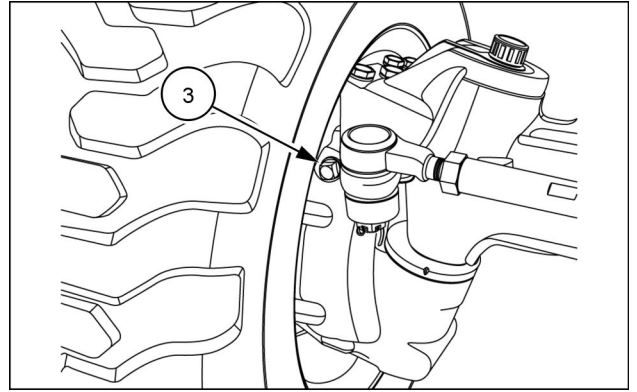

93110428 4

NOTE: Fluid capacity for the front axle housing see 7-10.

Transmission fluid - Change

Changing the transmission, rear axle and hydraulic system oil

NOTE: Change the transmission, rear axle, and hydraulic system oil after every 600 hours of operation.

NOTE: During cold weather operation, tractor hydraulic oil can be changed to **MULTI-SEASON HYDRAULIC TRANSMISSION OIL SAE 0W-20**. The **MULTI-SEASON HYDRAULIC TRANSMISSION OIL SAE 0W-20** oil is a multi-viscosity oil which has improved flow characteristics in low temperatures and can be used year round.

1. Place a suitable container beneath the transmission and rear axle drain plugs **(1)** (without Mid PTO) and **(2)** (With Mid PTO) to catch the used oil. With the oil at normal operating temperature, drain the system by removing the transmission and rear axle drain plugs. Reinstall the plugs once the oil has drained. Discard the used oil.

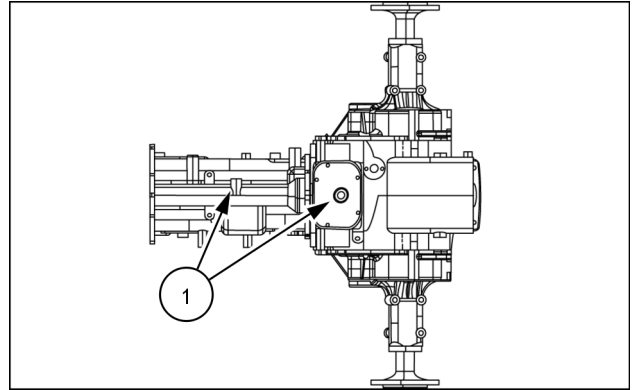

93100871 1

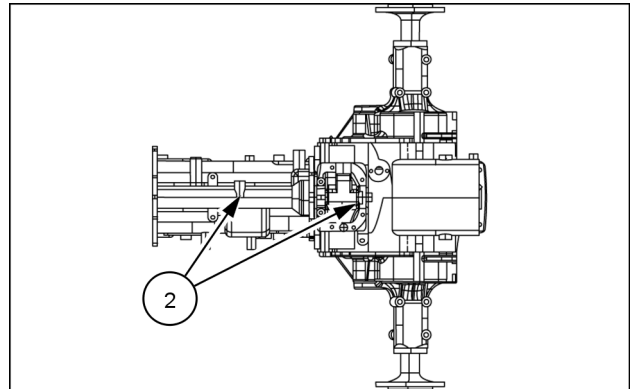

93100872 2

2. Remove the dipstick **(3)** and fill with **HYDRAULIC TRANSMISSION OIL - PREMIUM** hydraulic oil. The transmission is filled to the correct level when the oil registers between the two marks on the dipstick.

Capacity:

- Mechanical transmissionSee **7-10**
- HST transmissionSee **7-10**

3. Reinstall the dipstick .

NOTICE: There is a common sump for the transmission, rear axle, and hydraulic system. Therefore, extra care should be taken to keep the oil clean

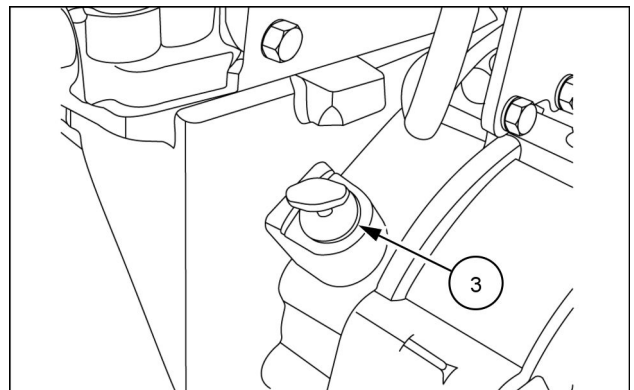

93099360 3

Every 1000 hours**Air cleaner inner element - Replace****⚠ WARNING**

Rotating parts!
Do not start the engine while you perform this procedure.
Failure to comply could result in death or serious injury.

W1374A

NOTE: For maximum engine protection and air cleaner service life, install a new inner safety element every third primary element change or after every 1000 hours of operation, whichever comes first.

Do not clean the air cleaner inner safety element (1). Replace the inner safety element when it becomes partially clogged. A clogged element will cause an air restriction resulting in a loss of engine power or excessive black exhaust smoke.

NOTE: Conduct a visual inspection of the inner safety element by placing a light inside the element. Little or no light will shine through the element if it is partially clogged.

To remove the inner safety element, pull it out of the canister body.

To install the new element, push it into the canister until seated.

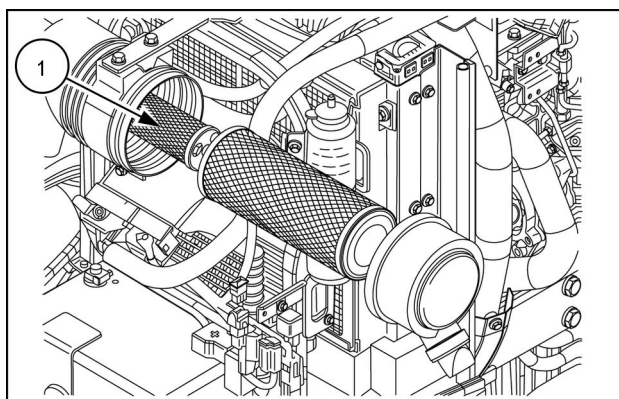

NHIL16CT00464AA 1

NOTICE: Clean any dirt from the canister before installing the inner safety element. Check element inner diameter seals for damage and replace the safety element if seal damage is present.

NOTICE: Failure to obtain a good seal between the filter and canister may cause major engine damage.

Every 1500 hours**Engine coolant - Draining and flushing****⚠ WARNING**

Hot liquid under pressure!
Never remove the filler cap or the recovery tank cap while the engine is running or the coolant is hot.
Let the system cool. Turn the filler cap to the first notch and allow any pressure to escape, and then remove the filler cap. Loosen the recovery tank cap slowly to allow any pressure to escape.
Failure to comply could result in death or serious injury.

W0296A

Draining and flushing the cooling system

NOTE: Drain and flush the radiator and engine block every 1500 hours of usage or 24 months, whichever comes first. Refill with a 50/50 mixture of permanent antifreeze and water. Change the coolant to **EXTENDED LIFE OAT COOLANT/ANTIFREEZE** see 7-7 .

To drain the cooling system:

1. Use a suitable receptacle to catch the used coolant. Remove the radiator cap and open the drain valve (1) on the left- side of radiator to drain the radiator and drain plug (2) on the left side of the engine block to drain engine block.
2. After the coolant has drained, place a water hose in the radiator filler neck and run water through the system. Start the engine when water flows from the block drain plug port. When the water flowing from the block port is free from coloration and sediment, stop the engine and remove the hose. Allow all water to drain from the system through the radiator drain valve and block port.
3. Close the radiator drain valve and reinstall the block drain plug. Slowly refill the system with a 50/50 solution of ethylene glycol antifreeze and water. Fill until the coolant level is approximately 4 cm (1.6 in) below the bottom of the filler neck. Do not fill beyond this level.
4. Clean the radiator cap, and cap seal, and install the cap.

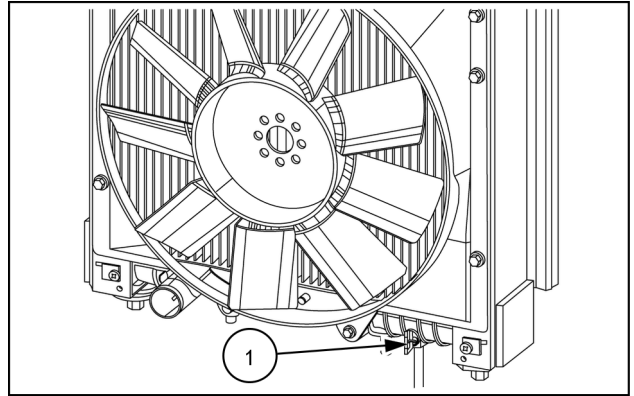

NHIL16CT00465AA 1

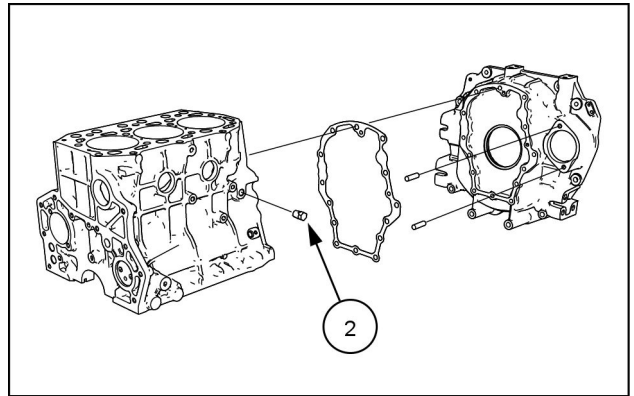

NHIL16CT00505AA 2

5. Add coolant to the coolant reservoir (3) until fluid level is between the “LOW” and “HIGH” lines on the side of the reservoir.
6. Normal operating temperature will be reached, then stop the engine. Check the coolant level when the engine is cold and add additional coolant as necessary.

NOTICE: Never run the engine when the cooling system is empty. Do not add cold water or cold antifreeze solution if the engine is hot.

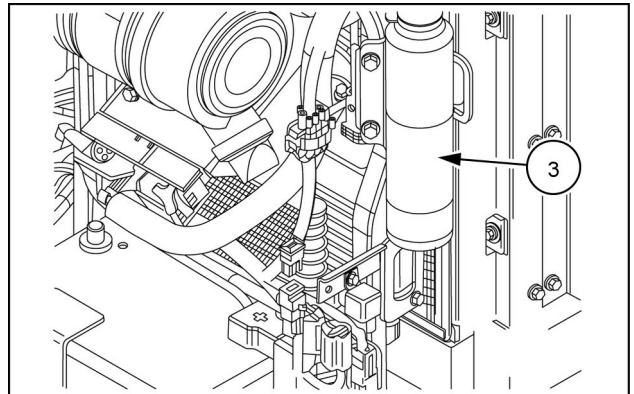

NHIL16CT00474AA 3

NOTE: Cooling system capacity see 7-10.

General maintenance

Hydrostatic transmission (HST) neutral adjustment - Check

1. See 7-27

Engine belts - Adjust

⚠ WARNING

Rotating parts!
Do not start the engine while you perform this procedure.
Failure to comply could result in death or serious injury.

W1374A

Fan and alternator belt

The belt (1) that drives the cooling fan and alternator is located at the front of the engine.

When **98 N (22 lb)** of pressure is applied midway between the belt pulleys, a correctly tightened belt will deflect **10 – 15 mm (0.4 – 0.6 in)** at point (A).

If the fan belt is slipping, fan efficiency is lowered, resulting in the engine running too hot. Or the alternator not charging. If the belt is too tight, the life of the alternator bearing will be shortened. If the fan belt shows signs of cracking or fraying, install a new one.

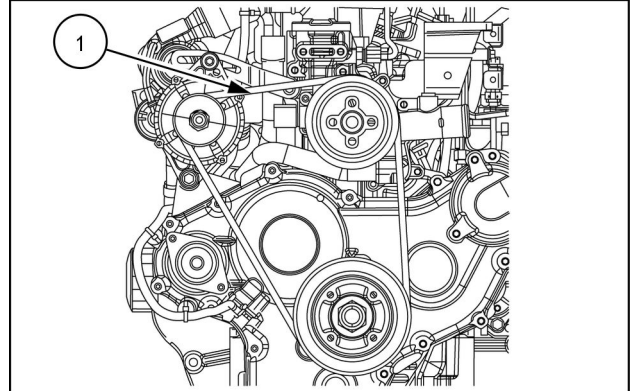

NHIL16CT00458AA 1

To adjust fan and alternator belt tension:

1. Loosen the two bolts (2) on the alternator, using a prybar; pull the alternator away from the engine to apply tension to belt.
2. When you achieve the proper belt tension, tighten the two alternator bolts.

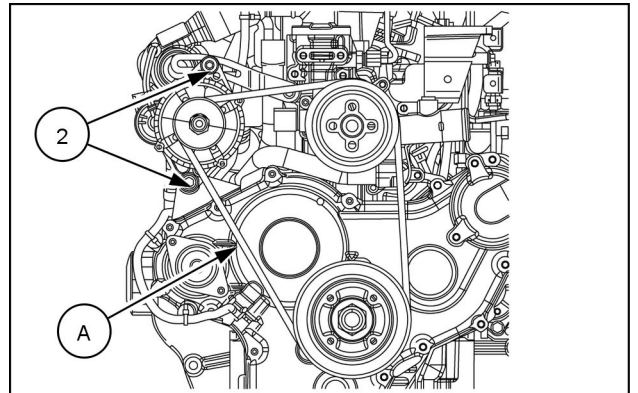

NHIL16CT00458AA 2

Roll Over Protective Structure (ROPS) - Replace - Possible damage

If the unit has rolled over or the ROPS has been in some other type of accident (such as hitting an overhead object during transport), the ROPS must be replaced to retain the best protection.

Following an accident, check the ROPS, the operator's seat, and the seat belt and seat belt mountings for possible damage. Before operating the machine, replace all damaged parts.

NOTICE: *Do not attempt to weld or straighten the ROPS.*

Battery

⚠ WARNING

Battery acid causes burns. Batteries contain sulfuric acid.

Battery electrolyte contains sulfuric acid. Contact with skin and eyes could result in severe irritation and burns. Always wear splash-proof goggles and protective clothing (gloves and aprons). Wash hands after handling.

Failure to comply could result in death or serious injury.

W0120A

The tractor is equipped with a BCI group 34, **12 V** battery (1) with a minimum cold cranking ability of **660 A** at **-18 °C (0 °F)**.

Make sure the battery connections are tight and free of corrosion. Use a solution of baking soda and water to wash the outside surface and terminals of the battery when necessary. However, make sure the solution does not get inside the battery. After cleaning, wash the battery with clean water, and then apply a small amount of petroleum jelly to the terminals to prevent corrosion. Maintain a good battery charge in freezing temperatures. If the battery discharges or becomes run down, the electrolyte becomes weak and may freeze, causing damage to the case.

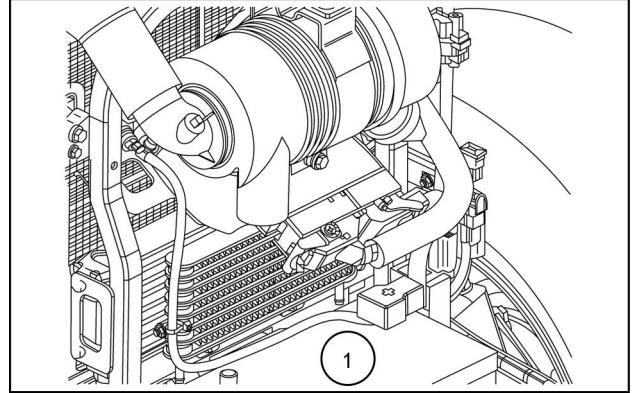

NHIL16CT00470AA 1

Alternator

The tractor's **70 A** alternator is belt-driven from the engine crankshaft pulley. Belt slippage will affect the charging system. Make sure that belt slippage does not occur. To adjust the belt, see **7-47**.

Other than belt adjustment, the only alternator maintenance required is a periodic inspection of the terminals to ensure they are clean and tight. Clean the alternator-cooling fan periodically.

When working on or checking the alternator, adhere to following precautions or alternator damage may occur:

- Do not **UNDER ANY CIRCUMSTANCES** short the field terminal of the alternator to ground.
- Do not disconnect the alternator output lead or battery cables while the alternator is operating.
- Do not remove the alternator from the tractor without first disconnecting the negative (-) battery cable. When removing the battery, disconnect the negative (-) cable first.
- To install a battery, **MAKE SURE** that you connect the positive (+) cable first, and that you connect the negative terminal to ground. Reverse polarity will destroy the rectifier diodes in the alternator.

If the battery charge warning light illuminates, indicating that the alternator is not charging the battery, check the fan belt and the wiring connections. If these items are in satisfactory condition and the warning light continues to indicate no charge, consult your **NEW HOLLAND Dealer**

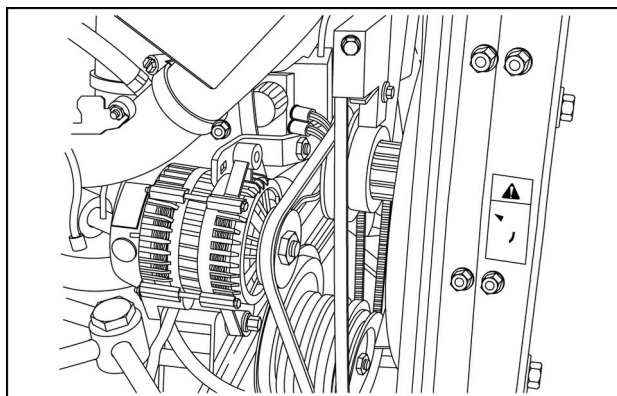

NHIL16CT00482AA 1

Headlight bulb - Replace

If head lamps, fail to operate, the bulb must be replaced.
To change the bulb:

1. Open the tractor hood.
2. Bulb Removal:
 - Work **(1)** and Road lights **(2)**. Turn bulb assembly $\frac{1}{4}$ turn and remove bulb from holder.
3. Bulb Replacement:
 - Road and Work lights: Insert bulb assembly into slots and turn $\frac{1}{4}$ turn clockwise to secure.
4. Rotate the socket counter-clockwise a quarter turn and remove the socket from the housing.
5. Remove the bulb assembly from the harness.
6. Place a new bulb in the socket, and then install the socket in the housing.

NOTICE: Be careful not to touch the bulb with bare fingers. Oil from the fingers can shorten the life of bulb. Use protective cloth or glove when installing bulb.

NOTE: Replacement bulbs are:

Work lights (upper): Bulb size, **27 W**, Halogen (Grille).

Work lights (upper): Bulb size, **37.5 W**, Halogen (Cab).

Work lights (upper): Bulb size, **27 W**, Halogen ROPS.

Road lights (lower): Bulb size, **55 W**, Halogen.

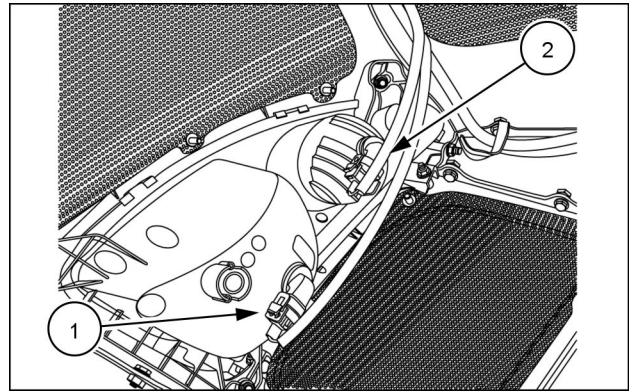

93100884 1

Turn signal/Hazard light bulb replacement

To replace a taillight bulb:

1. Remove the two screws (1) retaining the taillight lens and remove the lens.

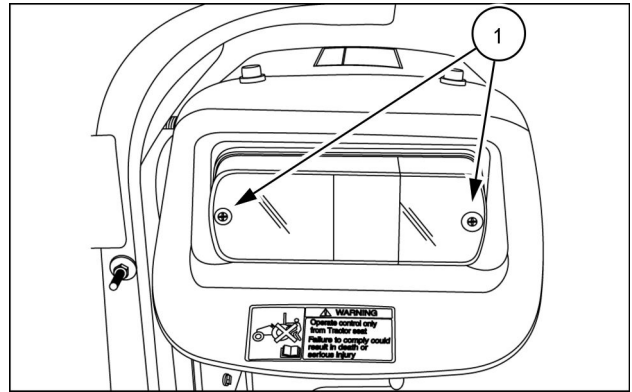

93100887 1

2. Push in on the brake/tail light bulb (2) or turn signal bulb (3) and rotate counter-clockwise in the socket to remove the old bulb.
3. Insert the new bulb into the socket and turn the bulb in a clockwise direction until tightened.

NOTE: Replace brake/tail bulb with a P21/5 watt bulb. and turn signal bulb with a R10 watt bulb

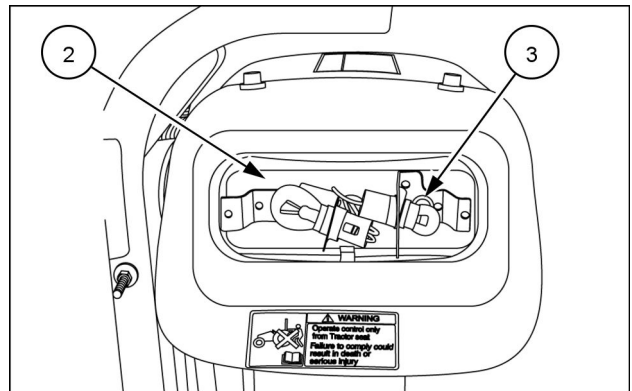

93100888 2

Flasher unit bulb - Replace

To replace the top flasher light bulb:

1. Remove the two screws (1) retaining the top flasher light lenses and remove the lenses.

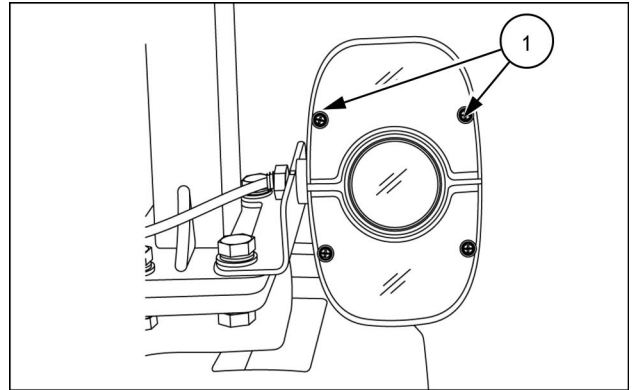

93100885 1

2. Push in on the bulb (2) and rotate bulb counter-clockwise in socket to remove.

NOTE: Replace with a P21 watt bulb.

3. Insert the new bulb into the socket and turn it clockwise until the bulb locks into place.
4. Install lenses and retaining screws.

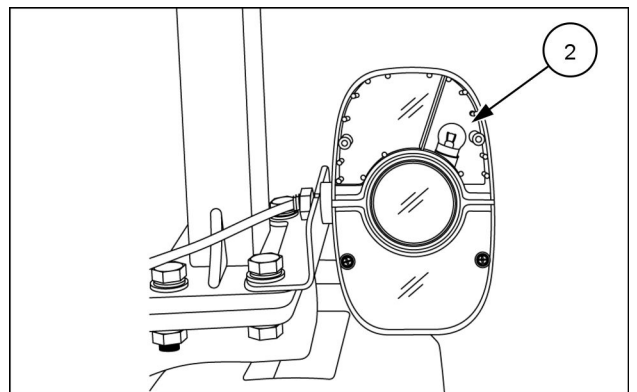

93100894 2

To replace the bottom flasher light bulb:

5. Remove the two screws (3) retaining the top flasher light lenses and remove the lenses.

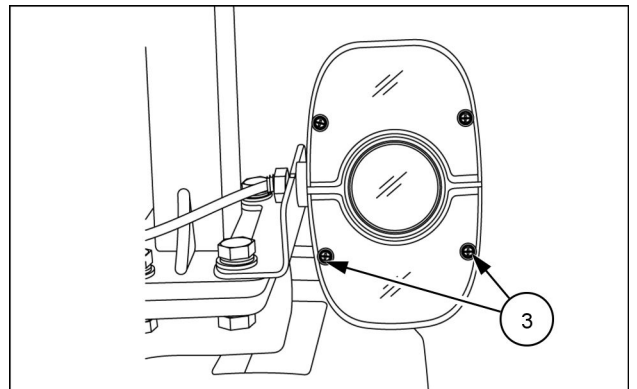

93100885 3

6. Push in on the bulb (4) and rotate bulb counter-clockwise in socket to remove.

NOTE: Replace with a R10 watt bulb.

7. Insert the new bulb into the socket and turn it clockwise until the bulb locks into place.
8. Install lenses and retaining screws.

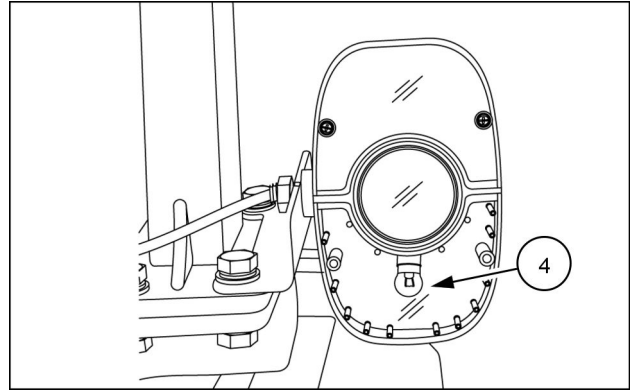

93100886 4

Wheels - Bolts and Nuts - Tighten

1. See 7-20

Front wheel toe-in - Adjust

If toe-in is not correct, adjust as follows:

1. Loosen the tie rod locknuts (1).
2. Adjust the tie rod tube assembly (2) as required to give **0 – 5 mm (0 – 0.2 in)** toe-in.
3. After the correct toe-in is obtained, tighten the tie rod locknuts.

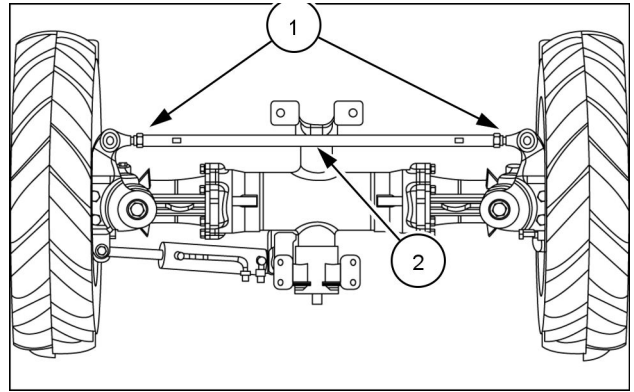

93100867 1

Brake pedal free play - Adjust

1. See 7-26

Clutch pedal free play - Adjust

1. See 7-25

Fuse and relay locations

Fuse and relay locations

Main fuse panel

The chassis fuse block (2) and relay center (1) are located on the left-hand side of the steering column, underneath the shrouding.

NOTICE: Always replace blown fuses with the size specified for that circuit.

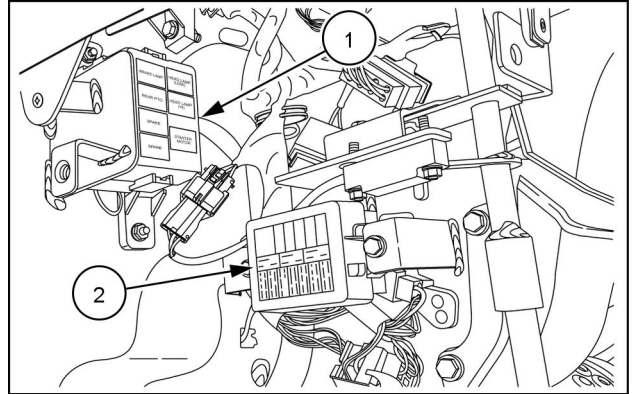

NHIL17CT00421AA 1

From top to bottom, the fuse block contains the following fuses:

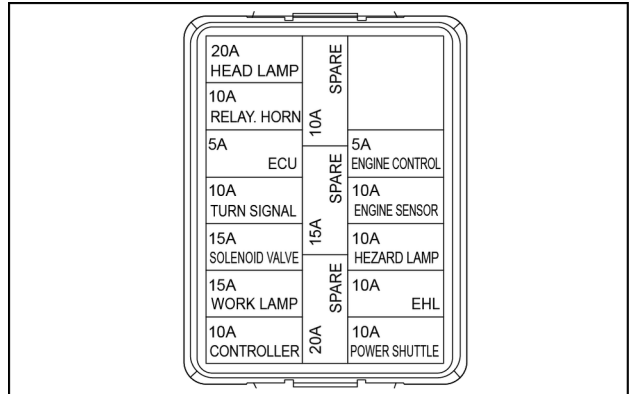

NHIL16CT00477AA 2

F-use #	F-use Size	Circuit	Circuits protected
1	20 A	Head lamp	Combination switch, head lamp relay, brake lamp relay, brake switch
2	10 A	Horn relay	Alternator, hazard switch, horn switch, Forward Neutral Reverse (FNR) switch, diesel particulate filter (DPF) switch, Engine Speed Management (ESM) switch
3	5 A	Engine control unit (ECU)	Engine control unit (ECU)
4	10 A	Turn signals	Hazard switch, Combination Switch
5	15 A	Solenoid valve	Rear Power Take Off (PTO) switch, rear PTO solenoid
6	15 A	Work lamps	Front corner lamp switch, 7 pin trailer connector
7	10 A	Controller	Cluster, Vehicle Control Unit (VCU), brake latch switch, seat switch

F-use #	F-use Size	Circuit	Circuits protected
8	10 A	Engine Control	Fuel heater relay, glow plug relay, starter motor relay,
9	10 A	Engine sensor	Cam position sensor, inlet metering valve, air mass flow sensor
10	10 A	Hazard lights	Hazard switch, cluster, diagnostic connector, main relay, engine, parking brake switch
11	10 A	EHL (Not used)	N/A
12	10 A	Power shuttle (Not used)	N/A

NOTE: The three fuses located in the center of the fuse block are spare fuses.

Engine Control Unit (ECU) main fuse

The ECU fuse is a **40 A fuse (1)** located beside the battery positive (+) terminal. This fuse protects the tractor's Engine Control Unit (ECU) system.

NOTICE: Always replace this fuse with a **40 A fuse**; DO NOT increase amperage rating.

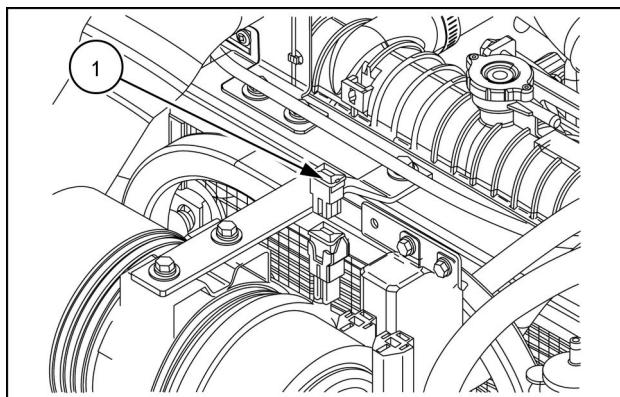

NHIL16CT00473AA 3

Storage

Tractor storage

Below is a list of protective measures which should be taken if your tractor is to be stored for an extended period of time:

1. Thoroughly clean the tractor. Use touch up paint where necessary to prevent rust.
2. Check the tractor for worn or damaged parts. Install new parts as required.
3. Raise the lift arms hydraulically to their fullest raised position so that the lift piston is in a fully extended position. This fills the cylinder with oil and protects the cylinder wall surfaces from corrosion.
4. Lubricate the tractor.
5. Fill the fuel tank with No. 1 diesel fuel.

NOTICE: Do not use No. 2 diesel fuel for winter storage because of wax separation and setting at low temperature.

6. Open the drain valve of the radiator and engine block. Flush the system, close the drain valves, and fill with a 50/50 solution of permanent antifreeze and clear water.
7. Remove the battery and clean it thoroughly. Be sure that it is fully charged and that the electrolyte is at the proper level. Store the battery in a cool, dry place above freezing temperature, and charge it periodically during storage.
8. Place blocking under the tractor axles to remove the weight from the tires.
9. Cover the exhaust pipe opening.

10. Depress the clutch pedal, engage the latch (1) with the pin (2) located on the clutch pedal. When the clutch pedal is locked in this position, the clutch disc will be separated from the flywheel.

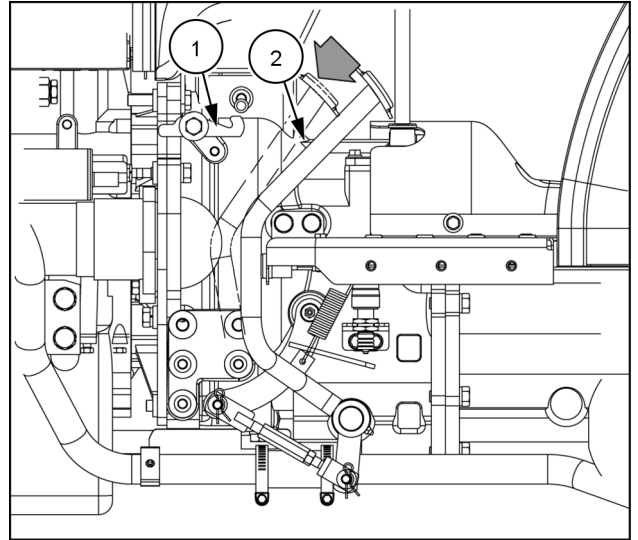

NHIL12CT00828AA 1

Removal of tractor from storage

Tractors which have been placed in storage should be completely serviced in the following manner before using:

1. Inflate the tires to the recommended pressures and remove the blocking.
2. Check the oil level in the engine crankcase, power steering reservoir, the common sump (for the hydraulic lift, transmission, and rear axle), and the optional front-wheel drive axle.
3. Install a fully charged battery and remove the exhaust cover if other than a rain cap.
4. Check the cooling system for the proper level (50/50 solution of antifreeze and clear water).
5. Start the engine and allow it to idle a few minutes. Ensure the engine is receiving lubrication and that each control is functioning correctly.
6. Drive the tractor without a load and check to make sure it is operating satisfactorily.

Touch-up paint

The following New Holland paints are recommended for touch-up paint repairs.

Color	Part No.	Amount
New Holland Bright Blue	86109144-DS	16 oz Spray
	86109141-DS	1 US qt
CNH Dark Gray	B96104	16 oz Spray
	B96105	1 US qt
Bianco White (Wheels)	9624698-DS	16 oz Spray
	9624699-DS	1 US qt
Med Gloss Black	94792-DS	16 oz Spray
	9624700-DS	1 US qt

8 - TROUBLESHOOTING

Symptom(s)

Engine - Troubleshooting

Problem	Possible Cause	Correction
The start motor does not rotate with the key switch in the (START) position.	Low battery charge	Charge or replace
	Loose battery or starter cable terminals	Tighten the terminal
	Key switch faulty	Repair or replace switch
	Safety start switch not completing circuit	Depress clutch pedal fully
	PTO safety switch is not in "OFF" position	Place PTO switch in "OFF" position
The start motor rotates but the engine does not start	Starter motor faulty	Repair or replace starter motor
	Low battery charge	Charge or replace battery
Engine speed is irregular	Air in fuel system	Bleed out the air
	Fuel filter clogged	Clean or replace the filter
	Injection nozzle clogged	Repair or replace nozzle
Engine stops suddenly during operation	Fuel leakage	Repair fuel system
	Fuel shortage	Add fuel and bleed air from fuel system
	Faulty fuel injector	Repair or replace injector
	Internal parts of engine seized due to lack of lubrication	Repair engine as needed
Engine stops suddenly during operation	Fuel shortage	Add fuel and bleed air from fuel system
	Faulty fuel injector	Repair or replace injector
	Internal parts of engine seized due to lack of lubrication	Repair engine as needed
Engine overheating	Lack of coolant	Add coolant as needed
	Fan belt slipping or belt is broken	Adjust belt tension or replace belt
	Dirt attached to the radiator or prescreen	Clean radiator fins or screen as needed
The color of exhaust smoke is white	Low engine operating temperature	Allow engine to obtain higher operating temperature
	Engine burning engine oil	Repair engine as needed
	Engine coolant entering engine exhaust	Repair engine as needed
The color of exhaust gas is black.	Air filter clogged	Clean or replace engine air filter
	Excessive fuel supply	Contact authorized dealer
	Faulty fuel injector	Contact authorized dealer
Low engine power	Fuel injector nozzle clogged	Repair injector as needed
	Carbon accumulation on valve seat	Repair valve and seats as needed
	Incorrect valve gap adjustment	Adjust valve gap to correct amount
	Lack of fuel supply	Check fuel system for restriction
	Air filter clogged	Clean or replace air filter
Instrument panel engine oil pressure indicator light is "ON" during operation.	Lack of engine oil	Add engine oil as needed
	Low viscosity of engine oil	Replace oil with proper viscosity type
	Faulty pressure switch	Replace switch
	Faulty engine oil pump	Repair oil pump as needed
Instrument panel battery charging indicator is "ON" during operation.	Engine oil filter clogged	Replace the filter
	Bad electrical connection	Check battery terminals, ground, and repair as needed

Problem	Possible Cause	Correction
	Faulty alternator	Repair or replace alternator as needed
	Faulty battery	Replace battery
	Incorrect fan belt tension or belt broken	Adjust belt tension or replace belt
Diesel Particulate Filter (DPF) not functioning properly	Excessive soot build up in (DPF)	Start regeneration of (DPF) system
	Engine Control Unit (ECU) not functioning properly	Contact authorized dealer for electronic diagnosis
Engine will only run for approximately thirty seconds	Excessive soot load in Diesel Particulate Filter (DPF)	Contact authorized dealer

Hydraulic Lift System - Troubleshooting

Problem	Possible Cause	Correction
The three-point linkage will not raise	Lack of transmission / hydraulic oil	Add oil as needed
	Air in the hydraulic suction pipe	Tighten the hydraulic filter and check all hydraulic suction connections
	Hydraulic filter clogged	Replace hydraulic filter
	Faulty hydraulic pump	Check pump for proper flow replace pump if needed
	Faulty control valve	Check hydraulic control valve and linkage for proper operation repair as needed
	Faulty hydraulic lift cylinder	Repair lift cylinder as needed
	Faulty hydraulic relief valve	Check hydraulic system for correct pressure setting, repair as needed
Oil leakage	Connecting part loosened	Tighten
	Oil seal damaged	Replace
	Pipe cracked	Replace
The three-point linkage does not move down when control handle is moved to down position.	Down speed control valve locked in closed position	Turn the knob counterclockwise, to open valve
	Control valve failure	Repair or replace valve
	Hydraulic lift cylinder damaged	Repair cylinder as needed
	Lift shaft moving parts damaged	Repair or replace lift shaft parts as needed

Steering - Troubleshooting

Problem	Possible Cause	Correction
Hydraulic steering system does not work	Faulty power steering pump	Replace pump if needed
	Steering unit damaged or worn	Repair or replace unit as needed
	Steering cylinder piston seal damaged or worn	Repair cylinder as needed
	External oil leakage of oil tubes or hoses	Repair or replace tubes or hoses as needed
Excessive steering wheel effort	Steering unit: Spline and column spline does not align	Check mounted condition of steering unit and column
	Steering unit: Spool and sleeve damaged by foreign material	Replace steering unit
	Steering unit: Excessive tightening torque of end cap bolt	Apply proper torque of end cap hardware
	Pump: Low flow	Increase engine RPM, to increase pump flow
	Faulty power steering pump	Check pump , repair or replace if needed
	Power steering relief valve: pressure setting low	Check power steering relief valve pressure adjust to proper pressure setting

Problem	Possible Cause	Correction
Cylinder movement not as smooth as steering wheel	Air in steering line if not used for a long time	Bleed air in steering system
	Air in suction tube	Check suction tube, repair as needed
	Cylinder piston seal damaged	Repair cylinder as needed
Front wheels turn the opposite direction to the steering wheel direction	Incorrect assembly of steering gear	Repair steering gear as needed
	Incorrect assembly of steering hoses	Assemble steering hoses correctly
Oil leakage of steering pump, steering unit, cylinder	Seal damaged	Replace seal
Abnormal noise	Lack of oil	Add oil as needed
	Restriction of oil flow in suction line	Replace filter
	Air in system	Bleed air from system

Hydrostatic transmission - Troubleshooting

Problem	Possible Cause	Correction
When operating HST pedal, tractor does not move.	HST high pressure relief valve pressure setting low	Check HST pressure and repair as needed
	HST charge pressure valve faulty	Check HST charge pressure and repair as needed
	HST Filter clogged	Replace HST filter
	HST pump faulty	Repair or replace HST pump
	HST control linkage worn or damaged	Repair or replace linkage as needed
Tractor is still moving when HST pedal is in neutral position	Incorrect neutral adjustment of HST linkage	Adjust neutral position of HST linkage
	HST pedal linkage damaged	Replace damaged linkage parts as needed
	HST control arm clamp bolt loose	Tighten control arm clamp bolt
HST power is low	Oil shortage	Add transmission oil as needed
	Air in HST circuit	Check and repair the hydraulic suction line
	Transmission oil temperature is too high	Shut down tractor to cool the transmission oil, and restart after oil temperature has been reduced
	HST internal parts worn	Repair HST transmission as needed
	HST filter clogged	Replace the HST filter
Abnormal noise	Engine speed is too low	Set engine speed over 1500 RPM
	Oil temperature is too low	Run engine to warm up the oil
	HST oil filter clogged	Replace the HST filter
	Oil shortage	Add transmission oil as needed

Electrical system - Troubleshooting

Problem	Possible Cause	Correction
Battery does not charge	Incorrect wiring	Check battery terminals and ground for corrosion
	Faulty Alternator	Test alternator repair or replace as needed
	Incorrect fan belt tension or broken belt	Adjust fan belt tension or replace belt
	Faulty battery	Replace battery
Headlights are dim	Battery charge is low	Charge or replace battery
	Faulty headlight wiring or faulty ground connection	Check and repair wiring as needed
Headlights will not illuminate	Light bulb burnt out	Replace bulb as needed
	Blown Fuse	Check the cause and replace fuse with correct size

8 - TROUBLESHOOTING

Problem	Possible Cause	Correction
	Faulty wiring connection	Check headlight wiring connection, repair as needed
	Faulty light switch	Check switch for proper function and replace if needed
Turn signal lights do not work	Light bulb burnt out	Replace bulb, with correct size
	Faulty wiring connection	Check wiring connections, repair as needed
	Blown fuse	Check the cause, replace fuse with correct size
	Faulty turn signal switch	Check switch for proper function, replace switch if needed
Cold start aid not working	Faulty connection of glow plug wiring	Check and repair glow plug wiring as needed.
	Blown fuse	Check for cause and replace fuse with correct size .
	Glow plug relay or safety controller faulty	Check relay and controller for proper function, replace as needed
	Faulty glow plugs	Check and replace glow plugs as needed.

9 - SPECIFICATIONS

Tire inflation pressures

Tire pressure must be considered when adding weights, implements, or attachments to the tractor or damage to the tractor may occur.

The chart below outlines tire inflation pressures.

FRONT TIRE INFLATION PRESSURES			
Tire Type	Tire Size	Recommended air pressure	Maximum load capacity at (Minimum inflation pressure)
Agricultural (R1)	7-14, 4PR, R1	41 – 248 kPa (6 – 36 psi)	160 kg (353 lb)
Turf (R3)	25 x 8.50-14, 10PR, R3	34 – 303 kPa (5 – 44 psi)	848 kg (1870 lb)
Industrial (R4)	25 x 8.50-14, 6PR, R4	207 – 345 kPa (30 – 50 psi)	716 kg (1579 lb)

REAR TIRE INFLATION PRESSURES			
Tire Type	Tire Size	Recommended air pressure	Maximum load capacity at (Minimum inflation pressure)
Agricultural (R1)	11.2-24, 4PR, R1	83 – 124 kPa (12 – 18 psi)	454 kg (1001 lb)
Turf (R3)	41 x 14.00-20, 4PR, R3	69 – 172 kPa (10 – 25 psi)	825 kg (1819 lb)
Industrial (R4)	43 x16-20, 4PR, R4	138 kPa (20 psi)	NA

NOTE: Do not under inflate or overinflate tires. Do not exceed maximum inflation pressure listed.

Rear wheel liquid ballast

Rear tire liquid

Ballast Weights (Per Tire) 600 g/5 lb Gal Solution/CaCl₂.

Tire Type	Tire Size	Approximate Added Weight
Agricultural	11.2-24, 4PR, R1	115 kg (254 lb)
Turf	41 x 14.00-20, 10PR, R3	157 kg (346 lb)
Industrial (R4)	43 x 16-20, 4PR, R4	234 kg (515 lb)

General specification

	Model Workmaster 35 Hydrostatic/Mechanical	Model Workmaster 40 Hydrostatic/Mechanical
Engine		
Type	Diesel	Diesel
Model	L3C19 - T5	L3C19 - T4
Emission level (tier)	Tier 4B (final)	Tier 4B (final)
Aspiration	Turbo	Turbo
Engine gross horsepower	26 kW (35 Hp)	29.8 kW (40.0 Hp)
Cylinders	3	3
Bore	88 mm (3 in) x	88 mm (3 in) x
Stroke	103 mm (4 in)	103 mm (4 in)
Displacement	1.879 L (114.6 in³)	1.879 L (114.6 in³)
Compression ratio	17.0:1	17.0:1
Firing order	1-3-2	1-3-2
Low idle speed	950 RPM	950 RPM
High Idle	2800 RPM	2800 RPM
Rated	2600 RPM	2600 RPM
Block type:		
	Cast iron	Cast iron
Lubrication:		
	Pressure Feed w/ trochoid Pump	Pressure Feed w/ trochoid Pump
Cooling system		
Type	Pressurized liquid with recirculating bypass	Pressurized liquid with recirculating bypass
Water pump:		
Type	Centrifugal	Centrifugal
Drive	V-Belt	V-Belt
Belt deflection	10 – 13 mm (0.4 – 0.5 in) when 10 kg (22 lb) pressure is applied midway between belt pulleys	10 – 13 mm (0.4 – 0.5 in) when 10 kg (22 lb) pressure is applied midway between belt pulleys
Fan diameter	380 mm (15.0 in)	380 mm (15.0 in)
Thermostat:		
Start to open	82 °C (179.6 °F)	82 °C (179.6 °F)
Fully Open	95 °C (203 °F)	95 °C (203 °F)
Radiator cap	90 kPa (12.8 psi)	90 kPa (12.8 psi)
Electrical system		
Alternator	12 V, Heavy duty, 70 A	12 V, Heavy duty, 70 A
Battery	12 V, w/ negative ground, 80 AH / 660 cca BCI Group 34	12 V, w/ negative ground, 80 AH / 660 cca BCI Group 34
Starting motor	Solenoid pre-engaged reduction	Solenoid pre-engaged reduction
Cold - start aid		
	Glow plug	Glow plug
Fuel system		
Fuel type	Diesel	Diesel
Type of fuel to use if above -7 °C (19 °F)	No. 2-Diesel, Cetane rating: minimum 40	No. 2-Diesel, Cetane rating: minimum 40
Type of fuel to use if below -7 °C (19 °F)	No. 1-Diesel, Cetane rating: minimum 40	No. 1-Diesel, Cetane rating: minimum 40
Sulphur content (Maximum) :	No. 1-Diesel	0.3%
Sulphur content (Maximum) :	No. 2-Diesel	0.3%

9 - SPECIFICATIONS

	Model Workmaster 35 Hydrostatic/Mechanical	Model Workmaster 40 Hydrostatic/Mechanical
Injection pump :		
Type	High pressure common rail	High pressure common rail
Timing	Varies:ECU controlled	Varies:ECU controlled
Mechanical Transmission		
Clutch		
Type	Dry disc	Dry disc
Number of clutches	1	1
Number of plates	1	1
Material	Organic	Organic
Plate diameter	240 mm (9.4 in) Transmission 12x12 Trans	240 mm (9.4 in) Transmission 12x12 Trans
Plate surface area	25133 mm ² (39 in ²)	25133 mm ² (39 in ²)
Method of operation	Foot-Mechanical	Foot-Mechanical
Pedal : Free-travel	20 – 30 mm (0.79 – 1.2 in)	20 – 30 mm (0.79 – 1.2 in)
HST Transmission		
Number of range gears and speeds	3	3
Range synchronization	None	None
Number of gear levers	1	1
Cruise control offering	STD	STD
Cruise control type	Mechanical latch	Mechanical latch
High pressure relief valve setting	39224 kPa (5689 psi)	39224 kPa (5689 psi)
Trans/rear axle oil capacity	32 L (8.5 US gal)	32 L (8.5 US gal)
Service brake		
Type	Wet disc	Wet disc
Actuation	Mechanical	Mechanical
Number of plates - per axle	2	2
Total number pf Plates	4	4
Disc lining diameter OD	223 mm (8.78 in)	223 mm (8.78 in)
Disc lining diameter ID	174 mm (6.85 in)	174 mm (6.85 in)
Lining type (Material)	Paper	Paper
Service brake pedal parking lock	Yes	Yes
Parking brake		
Type	Latch	Latch
Location	Pedal linkage	Pedal linkage
Actuation	Mechanical	Mechanical
Number of plates	4	4
Steering		
Type	Power	Power
Turns lock-to-lock:		
FWD	3.92 L to R 3.30 R to L	3.92 L to R 3.30 R to L
Front wheel		
Toe-in	0 – 5 mm (0 – 0.20 in)	0 – 5 mm (0 – 0.20 in)
Turning radius w/o brakes:		
FWD	3121 mm (123 in) Left turn 3137 mm (124 in) Right turn	3121 mm (123 in) Left turn 3137 mm (124 in) Right turn
Steering system relief valve setting	120 Kg/cm ² (1707 psi)	120 Kg/cm ² (1707 psi)

9 - SPECIFICATIONS

	Model Workmaster 35 Hydrostatic/Mechanical	Model Workmaster 40 Hydrostatic/Mechanical
Maximum pump flow:	18.2 L/min (4.8 US gpm) Mechanical, 18.2 L/min (4.8 US gpm) HST	18.2 L/min (4.8 US gpm) Mechanical ,18.2 L/min (4.8 US gpm) HST
Power Take - Off (Rear)		
Type	Independent	Independent
Clutch type	Wet disc	Wet disc
Clutch material, asbestos free (Yes or No)	Yes	Yes
Number of plates	6	6
Plate diameter	90.0 mm (3.5 in)	90.0 mm (3.5 in)
Plate surface area	3145.0 mm² (4.9 in²)	3145.0 mm² (4.9 in²)
Actuation	Switch	Switch
Number of splines	6	6
Shaft size:	35.0 mm (1.4 in)	35.0 mm (1.4 in)
Engine speed for 540 RPM rear PTO operation	2509 RPM - HST 2509 RPM - Mechanical	2509 RPM - HST 2509 RPM - Mechanical
PTO Horsepower observed	19.2 kW (25.7 Hp) - HST 20.4 kW (27.4 Hp) - Mechanical	21.6 kW (29.0 Hp) - HST 23.0 kW (30.8 Hp) Mechanical
Mid PTO (optional)		
Type	Independent	Independent
Clutch type	Wet disc	Wet disc
Number of plates	6	6
Actuation	Manual lever	Manual lever
Direction of rotation (As viewed from rear of tractor)	Clockwise	Clockwise
Number of splines	15	15
Shaft size:	25.4 mm (1 in)	25.4 mm (1 in)
Engine Speed for 2000 RPM mid PTO operation	2545 RPM - HST Transmission 2545 RPM - Mechanical Transmission	2545 RPM - HST Transmission 2545 RPM - Mechanical Transmission
Hydraulic lift system		
Type	Open center	Open center
Pump type	Gear	Gear
Pump capacity	31.2 L (8.2 US gal)	31.2 L (8.2 US gal)
System relief valve setting	16671 kPa (2418 psi)	16671 kPa (2418 psi)
Transmission speeds (Hydrostatic)		
	(2600 RPM Engine rated speed with 11.2-24 Rear tires)	(2600 RPM Engine rated speed with 11.2-24 Rear tires)
Gear position:		
Low	0 – 5.23 km/h (0 – 3.251 mph)	0 – 5.23 km/h (0 – 3.251 mph)
Mid	0 – 10.69 km/h (0 – 6.64 mph)	0 – 10.69 km/h (0 – 6.64 mph)
High	0 – 24.07 km/h (0 – 14.96 mph)	0 – 24.07 km/h (0 – 14.96 mph)
Reverse low	0 – 5.23 km/h (0 – 3.25 mph)	0 – 5.23 km/h (0 – 3.25 mph)
Reverse mid	0 – 10.69 km/h (0 – 6.64 mph)	0 – 10.69 km/h (0 – 6.64 mph)
Reverse high	0 – 24.07 km/h (0 – 14.96 mph)	0 – 24.07 km/h (0 – 14.96 mph)
Transmission speeds (Mechanical)		
	(2600 RPM Engine rated speed with 11.2-24 Rear tires)	(2600 RPM Engine rated speed with 11.2-24 Rear tires)
Gear position: forward		
Range Low, 1st gear	1.19 km/h (0.74 mph)	1.19 km/h (0.74 mph)

9 - SPECIFICATIONS

	Model Workmaster 35 Hydrostatic/Mechanical	Model Workmaster 40 Hydrostatic/Mechanical
Range Low, 2nd gear	1.73 km/h (1.07 mph)	1.73 km/h (1.07 mph)
Range Low, 3rd gear	2.24 km/h (1.39 mph)	2.24 km/h (1.39 mph)
Range Low, 4th gear	2.76 km/h (1.72 mph)	2.76 km/h (1.72 mph)
Range Mid, 1st gear	3.23 km/h (2.01 mph)	3.23 km/h (2.01 mph)
Range Mid, 2nd gear	4.71 km/h (2.93 mph)	4.71 km/h (2.93 mph)
Range Mid, 3rd gear	6.12 km/h (3.80 mph)	6.12 km/h (3.80 mph)
Range Mid, 4th gear	7.54 km/h (4.68 mph)	7.54 km/h (4.68 mph)
Range High 1st gear	9.39 km/h (6.14 mph)	9.39 km/h (6.14 mph)
Range High, 2nd gear	14.42 km/h (8.95 mph)	14.42 km/h (8.95 mph)
Range High, 3rd gear	18.71 km/h (11.61 mph)	18.71 km/h (11.61 mph)
Range High, 4th gear	23.07 km/h (14.33 mph)	23.07 km/h (14.33 mph)
Gear position: reverse		
Range Low, 1st gear	1.13 km/h (0.70 mph)	1.13 km/h (0.70 mph)
Range Low, 2nd gear	1.64 km/h (1.02 mph)	1.13 km/h (0.70 mph)
Range Low, 3rd gear	2.13 km/h (1.32 mph)	2.13 km/h (1.32 mph)
Range Low, 4th gear	2.63 km/h (1.63 mph)	2.63 km/h (1.63 mph)
Range Mid, 1st gear	3.07 km/h (1.91 mph)	3.07 km/h (1.91 mph)
Range Mid, 2nd gear	4.48 km/h (2.78 mph)	4.48 km/h (2.78 mph)
Range Mid, 3rd gear	5.81 km/h (3.61 mph)	5.81 km/h (3.61 mph)
Range Mid, 4th gear	7.17 km/h (4.46 mph)	7.17 km/h (4.46 mph)
Range High 1st gear	9.40 km/h (5.84 mph)	9.40 km/h (5.84 mph)
Range High, 2nd gear	13.71 km/h (8.52 mph)	13.71 km/h (8.52 mph)
Range High, 3rd gear	17.78 km/h (11.05 mph)	17.78 km/h (11.05 mph)
Range High, 4th gear	21.93 km/h (13.63 mph)	21.93 km/h (13.63 mph)
Cast iron weights		
Front end:		
With weight extension bracket installed	(5) weights @ 26 kg (60 lb) each	(5) weights @ 26 kg (60 lb) each
With weight extension bracket installed	Optional (3) weights @ 45 kg (100 lb) each	Optional (3) weights @ 45 kg (100 lb) each
Rear wheel:		
R-4 Tires	NA	NA
Turf Tires	NA	NA
Ag. Tires	NA	NA
Drawbars		
Adjustable	Standard	Standard
Tires		
Front :		
Agricultural:	7-14, 6PR, R1	7-14, 6PR, R1
Turf:	25 x 8.50-14, 10PR, R4	25 x 8.50-14, 10PR, R4
Industrial:	25 x 8.50-14, 6PR, R4	25 x 8.50-14, 6PR, R4
Rear :		
Agricultural	11.2-24, 4PR, R1	11.2-24, 4PR, R1
Turf	41 x 14.00-20, 4PR, R3	41 x 14.00-20, 4PR, R3
Industrial	43 x 16-20, 4PR, R4	43 x 16-20, 4PR, R4
Wheel bolt torques		
Front wheel --- disc-to-hub:		
FWD	176 – 196 N·m (130 – 145 lb ft)	176 – 196 N·m (130 – 145 lb ft)

9 - SPECIFICATIONS

	Model Workmaster 35 Hydrostatic/Mechanical	Model Workmaster 40 Hydrostatic/Mechanical
Rear wheel --- disc-to axle	176 – 196 N·m (130 – 145 lb ft)	176 – 196 N·m (130 – 145 lb ft)
ROPS attaching bolt torques		
ROPS to rear axle	147 N·m (108 lb ft)	147 N·m (108 lb ft)
Seat belt	54 N·m (40 lb ft)	54 N·m (40 lb ft)

Dimensions

	Workmaster 35	Workmaster 40
(1) - MINIMUM GROUND CLEARANCE (under drawbar):		
Ind. Tires: 43 x 16-20	336 mm (13 in)	336 mm (13 in)
WHEEL TREAD SETTINGS:		
(2)-FRONT:		
Ind. Tires: 25 x 8.50-14 6 PR (Dished In Only)	1115 mm (44 in)	1115 mm (44 in)
(3)-REAR:		
Ind. Tires 43 x 16-20 (Dished In Only)	1091 mm (43 in)	1091 mm (43 in)
(4) - WIDTH (Maximum) :		
Rear Axle - Outside to Outside of rear tire:		
Ind. Tires: 43 x 16-20		
Dished In (Only)	1374 mm (54 in)	1374 mm (54 in)
(5) - Top of ROPS - Folding: Up position		
Ind. Tires: 43 x 16-20		
Up Position	2252 mm (89 in)	2252 mm (89 in)
(6) - WHEEL BASE:		
FWD	1754 mm (69 in)	1754 mm (69 in)
(7) - LENGTH:		
FWD:	3401 mm (134 in)	3401 mm (134 in)
WEIGHT With ROPS / less tires:		
HST (FWD)	1089 kg (2400 lb)	1089 kg (2400 lb)
Mechanical (FWD)	1084 kg (2390 lb)	1084 kg (2390 lb)

9 - SPECIFICATIONS

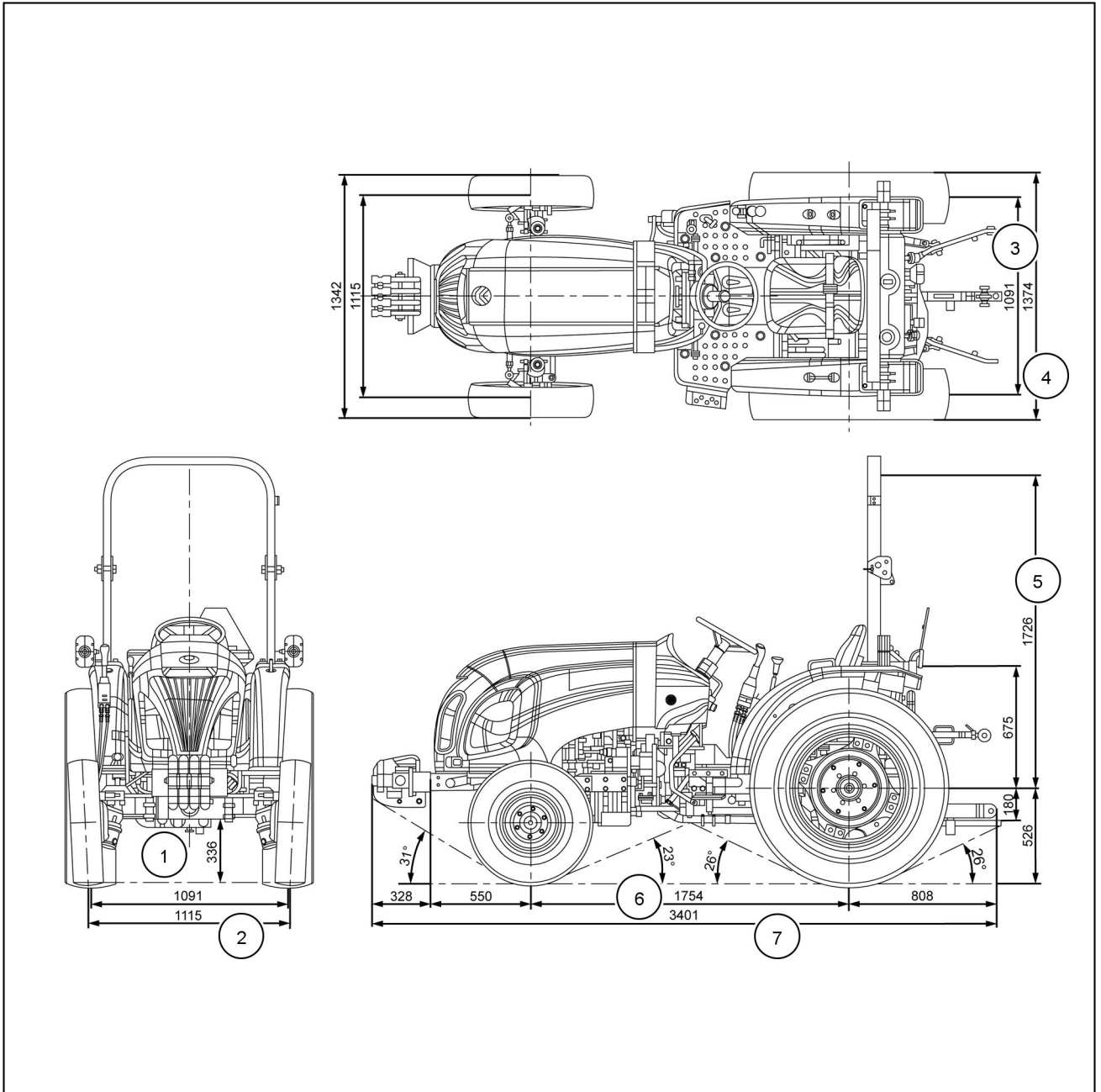

NHIL23CT00443GA 1

10 - ACCESSORIES

Accessories

Grille guard

An optional pivoting front grille guard provides protection to the front of the tractor. The grille guard is compatible with a front end loader or a maximum of three **45 kg (100 lb)** weights with front weight bracket.

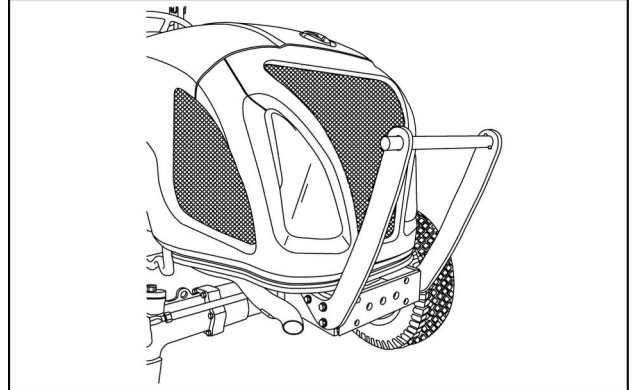

NHIL15CT00377AA 1

11 - FORMS AND DECLARATIONS

Delivery report - owner copy

Check and adjust as required

Workmaster™ 35/40

Inoperative service checks

1. Tire pressure
2. Air cleaner element & hose connections
3. Radiator coolant level
4. Engine belts tension
5. Battery charge
6. Engine oil level
7. Transmission & rear axle oil level
8. Front axle oil level
9. Hydraulic lift control drop rate adjustment
10. Top link (present)
11. Brake pedal adjustment
12. Wheel bolt torque -
 Front and Rear **176 – 196 N·m (130 – 145 lb ft)**
13. Front wheels toe-in
14. Fuel level

Safety items check

- 1. _____ Seat Belts Installed
- 2. _____ PTO shield installed
- 3. _____ SMV emblem installed
- 4. _____ Safety decals installed
- 5. _____ Neutral start switches operation
- 6. _____ Park brake operation
- 7. _____ Hazard lights/tail lights operation
- 8. _____ Front and cab lights operation
- 9. _____ Operator's Manual (present)

Operative service checks

Perform all operating checks with the tractor at normal operating temperature.

- 1. _____ Lights and instruments for proper operation and Fuel Shut Down with Key Switch Off
- 2. _____ Fluid and oil leaks
- 3. _____ Maximum no-load high and idle speeds:
(Max: 2800 RPM, Idle: 850RPM)
- 4. _____ PTO engagement and disengagement
- 5. _____ Three point hitch operation
- 6. _____ FWD- operation
- 7. _____ Hydrostatic transmission (HST) operation
- 8. _____ Explain safe operation of (DPF) emission system
- 9. _____ Operation of air conditioning / heating system

Dealer Representative's Signature _____ Date _____

"I have been instructed in the operation, maintenance, and safety features of this machine as detailed in the operator's manual."

Owner's Signature _____ Date _____

Delivery report - dealer copy

Check and adjust as required

Workmaster™ 35/40

Inoperative service checks

1. Tire pressure
2. Air cleaner element & hose connections
3. Radiator coolant level
4. Engine belts tension
5. Battery charge
6. Engine oil level
7. Transmission & rear axle oil level
8. Front axle oil level
9. Hydraulic lift control drop rate adjustment
10. Top link (present)
11. Brake pedal adjustment
12. Wheel bolt torque -
 Front and Rear **176 – 196 N·m (130 – 145 lb ft)**
13. Front wheels toe-in
14. Fuel level
15. Perform a forced regeneration (See **Diesel Particulate (DPF) regeneration** to perform this operation.)

Safety items check

1. Seat Belts Installed
2. PTO shield installed
3. SMV emblem installed
4. Safety decals installed
5. Neutral start switches operation
6. Park brake operation
7. Hazard lights/tail lights operation
8. Front and cab lights operation
9. Operator's Manual (present)

Operative service checks

Perform all operating checks with tractor at normal operating temperature.

1. _____ Lights and instruments for proper operation and Fuel Shut Down with Key Switch Off
2. _____ Fluid and oil leaks
3. _____ Maximum no-load high and idle speeds:
(Max: 2800 RPM, Idle: 850 RPM)
4. _____ PTO engagement and disengagement
5. _____ Three point hitch operation
6. _____ FWD- operation
7. _____ Hydrostatic transmission (HST) operation
8. _____ Explain safe operation of (DPF) emission system
9. _____ Operation of air conditioning / heating system

Dealer Representative's Signature _____ Date _____

"I have been instructed in the operation, maintenance, and safety features of this machine as detailed in the operator's manual."

Owner's Signature _____ Date _____

Index

A

Accessories	10-1
Access to operator's platform	3-1
Air cleaner - Clean - Primary element	7-33
Air cleaner inner element - Replace	7-45
Air cleaner primary element - Replace	7-38
Alternator	7-50
Attaching three-point equipment	4-11

B

Ballast	6-1
Ballast weight requirements	6-2
Battery	7-49
Brake pedal	3-19
Brake pedal free play - Adjust	7-26, 7-57
Brakes	4-28
Brakes and controls - Driving	5-6
Brakes and controls - Towing	5-7

C

Capacities	7-10
Change engine coolant to Organic Acid Technology (OAT) coolant	7-7
Clutch pedal	3-18
Clutch pedal free play - Adjust	7-25, 7-58

D

Delivery report - dealer copy	11-3
Delivery report - owner copy	11-1
Diesel Particulate Filter (DPF) regeneration	4-2
Differential lock lever - Operating	3-25
Dimensions	9-8
Do not operate tag	2-9
DPF switch	3-30
Drawbar - Operating	4-14
Drop rate control valve	4-16

E

Ecology and the environment	2-11
Electrical system - Troubleshooting	8-3
Electromagnetic Compatibility (EMC)	1-4
Emergency stopping the engine	4-27
Emissions overview	1-10
Engine belts - Adjust	7-47
Engine break-in procedure	4-1
Engine coolant - Draining and flushing	7-45
Engine cooling system - Check	7-14
Engine fault code display	3-9
Engine oil and oil filter - Change	7-15, 7-34
Engine oil level - Check	7-12
Engine speed management	4-7
Engine Speed Management (ESM) switch	3-28
Engine Speed Management (ESM) Up/Down switch	3-29
Engine - Troubleshooting	8-1
External lighting	5-1

F

Flasher unit bulb - Replace	7-53
---------------------------------------	------

Fluids and lubricants	7-9
Foot throttle pedal	3-20
Four-Wheel Drive(4WD) lever	3-33
Front axle and differential fluid - Change	7-42
Front axle and differential oil level - Check	7-32
Front wheel toe-in - Adjust	7-56
Fuel filter - Drain	7-34
Fuel filter water separator - Replace.	7-39
Fuel water seperator filter - Replace.	7-21
Fuse and relay locations	7-59
G	
General information	7-1
General specification	9-3
General specification - Biodiesel fuels	7-4
General specification - Diesel fuel	7-3
Glow plugs - Cold start aid	4-18
Grease fittings - Lubricate	7-22
H	
Hand throttle lever	3-21
Headlight bulb - Replace.	7-51
Hood release latch	3-41
Horn switch (optional)	3-22
Hydraulic Lift System - Troubleshooting	8-2
Hydraulic oil filter - Replace	7-17
Hydraulic Power Lift (HPL)	3-35
Hydrostatic transmission (HST) neutral adjustment - Check	7-46
Hydrostatic Transmission (HST) neutral position - Check and Adjust.	7-27
Hydrostatic Transmission (HST) oil filter - Replace - HST system	7-36
Hydrostatic transmission oil filter - Replace.	7-18
Hydrostatic transmission - Operate	3-16
Hydrostatic transmission - Operation	4-33
Hydrostatic transmission pedal - Operating.	3-26
Hydrostatic transmission - Troubleshooting.	8-3
I	
Instructional signs	2-27
Instrument panel	3-5
Intended use	1-2
K	
Key switch	3-24
Key switch - Operating	4-17
L	
Liquid ballast.	6-4
M	
Machine orientation	1-9
Maintenance chart	7-11
Mechanically - adjusted operator seat	3-2
Mechanical transmission external controls - Operation.	4-35
Mechanical transmission lever	3-40
Mid-mount control valve	3-38
Mid Power Take-Off (PTO) (optional)	3-34
Multifunction light switch	3-28
N	
Note to the owner.	1-1
O	
Oil filter - Replace.	7-35
Operator's manual storage.	1-8

P

Park brake	3-32
Parking the tractor	4-37
Power Take-Off (PTO) operation	4-8
Power Take-Off (PTO) switch	3-23
Product Identification Number (PIN) (ROPS)	1-7
Product identification plate	1-5

R

Rear remote control valve(s) - optional	3-36
Rear wheel liquid ballast	9-2
Refueling the tractor	7-6
Removal of tractor from storage	7-61
Road lights - Operation	5-4
Roll Over Protective Structure (ROPS)	3-3
Roll Over Protective Structure (ROPS) - Check	7-19
Roll Over Protective Structure (ROPS) frame - Personal safety	2-10
Roll Over Protective Structure (ROPS) - Replace - Possible damage	7-48

S

Safety features	2-35
Safety rules	2-2
Safety rules and signal word definitions	2-1
Safety signs	2-12
Seat belt	3-1
Shuttle lever	3-17
Starting the engine (Hydrostatic transmission)	4-22
Starting the engine (Mechanical)	4-19
Starting the engine with jumper cables	4-25
Steering - Operation	4-31
Steering - Troubleshooting	8-2
Steering wheel - Adjust	4-30
Stopping the engine	4-26

T

Three-point hitch	4-10
Tilt steering lever - Operating	3-27
Tire inflation pressure - Check	7-30
Tire inflation pressures	9-1
Top link installation	4-15
Tractor storage	7-60
Transmission fluid - Change	7-44
Transmission fluid level - Check	7-24
Transmission range lever	3-31
Transmission - Warm-up	4-32
Transporting by truck or trailer	5-7
Turn signal/Hazard light bulb replacement	7-52
Turn signal / Hazard lights - Identification	5-2
Turn signal / Hazard lights - Operation	5-3

W

Wheel bolts and nuts - Check	7-37
Wheels - Bolts and Nuts - Tighten	7-20, 7-55
Work lights - Operation	5-5

Dealer's stamp

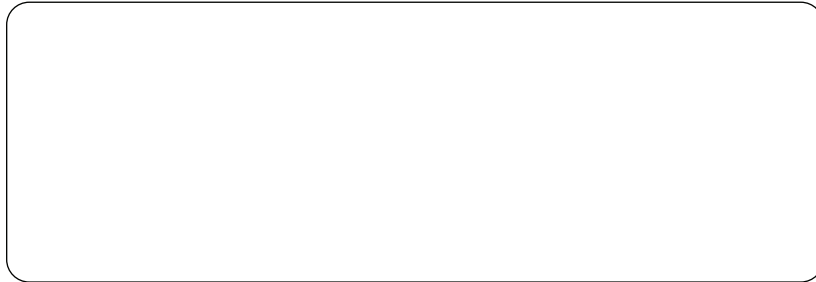

CNH Industrial America LLC reserves the right to make improvements in design and changes in specifications at any time without notice and without incurring any obligation to install them on units previously sold.

Specifications, descriptions, and illustrative material herein are as accurate as known at time of publication, but are subject to change without notice.

Availability of some models and equipment builds varies according to the country in which the equipment is being used. For exact information about any particular product, please consult your New Holland dealer.



© 2023 CNH Industrial America LLC. All Rights Reserved.

New Holland is a trademark registered in the United States and many other countries, owned or licensed to CNH Industrial N.V., its subsidiaries or affiliates.

Any trademarks referred to herein, in association with goods and/or services of companies, other than owned by or licensed to CNH Industrial N.V., its subsidiaries or affiliates, are the property of those respective companies.