



ENGINE

Model	FPT F5B FL413D*C001
Emissions Certification	Tier 4 Final
Type	Diesel, Turbo – Direct Injection
Cylinders	4
Bore/Stroke	3.9 x 4.3 in (99 x 110 mm)
Displacement	207 in ³ (3.4 L)
Fuel injection	Direct, high pressure common rail – HPCR
Fuel	#2 Diesel
Fuel filter:	
Pre-filter	Beta (30) = 200/spin-on
Main filter	Beta (4) = 20/spin-on
Air intake	Turbocharged w/ waste gate and external cooled EGR
Exhaust aftertreatment	Selective Catalytic Reduction – SCR
Cooling	Liquid
Engine speeds	RPM
High idle – no load	2500 +/- 25
Rated – full load	2500
Low idle	1150 +/- 25
Horsepower @ 2500 RPM – SAE J1349:	
Gross	90 hp (67 kW)
Net	84 hp (63 kW)
Peak torque @ 1400 RPM	282 lb-ft (383 N·m)
Radiator:	
Core type	Aluminum bar and plate
Core size area	2.21 ft ² (0.206 m ²)
Rows of tubes	21
Cap pressure	16 +/- 2 psi (1.10 +/- 0.14 bar)
Fan:	
Diameter	22 in (560 mm)
Ratio	1.1:1
Water pump:	
Style	Centrifugal
Flow	47.8 gpm (181 L/min)
Engine lubrication pump	Rotor pump w/ deep sump pan, plate cooler and pressurized under-piston nozzles
Pump operating angle ratings:	
Side to side	45°
Bucket up	35°
Bucket Down	45°

LIFT GEOMETRY

Vertical Lift

DRIVETRAIN

Drive pump controls	Servo-assist mechanical
Pump to engine ratio	1:1
Displacement	2.81 in ³ (46 cm ³)
Flow @ rated engine RPM:	
@ 97% efficiency	29.4 gpm (111 L/min)
Charge pressure	360 psi (24.5 bar)
System relief pressure	5,220 psi (360 bar)

Drive pump controls	Electro-hydraulic
Pump to engine ratio	1:1
Displacement	2.75 in ³ (45 cm ³)
Flow @ rated engine RPM:	
@ 97% efficiency	28.8 gpm (109 L/min)
Charge pressure	362 psi (25 bar)
System relief pressure	5,220 psi (360 bar)

Drive motors:	
Max. displacement	28.7 in ³ (470 cm ³)
Displacement:	
High speed	17.2 in ³ (282 cm ³)
Motor RPM @ high idle and 97% efficiency:	
2-speed	355
Motor torque @ max. displacement and relief pressure, calculated @ 5,220 psi (360 bar):	1,987 lb-ft (2 694 N·m)

Travel speed:	
Low range	7.7 mph (12.4 kph)
High range	11.5 mph (18.5 kph)

Final drive	Single-reduction chain drive
-------------	------------------------------

Drive chain:	
Size	ASA #100
Tensile strength	30,000 lb (133.4 kN)

Axles:	
Torque @ max. displacement and relief pressure	5,957 lb-ft (8 077 N·m)
Diameter	2.44 in (62 mm)
Length	15.6 in (396 mm)

Parking brake:	
Type	Spring-applied, hydraulic release multiple disc.
Engagement	Depress on/off brake button on handle or instrument panel, raise seat bar, get off seat or stop engine.

ELECTRICAL

Alternator	160 amp
Starter	4.29 hp (3.2 kW)
Battery	12-volt low-maintenance 1,000 cold-cranking amps @ 0° F (-18° C°)

OPERATOR ENVIRONMENT

ROPS/FOPS Level 1 canopy w/ side screens;
Keyed start ignition; Tilt ROPS/FOPS; Rear
window w/ emergency escape; Deluxe cloth,
suspension seat, w/ 2 in (51 mm) retractable 3
point lap seat belt, w/ heater and lumbar support;
Hand and foot throttle; Alarm package – back-up

and horn; Rearview mirror; Headliner; Dome
Light; Top window; Cup holder; 12V Power plug
socket; Foot rest; Seat Pocket; Padded seat bar
w/ integral armrests; Loader control lockout
system; Electric parking brake control; Operator's
compartment floor cleanout; Proportional
auxiliary hydraulic control – on joystick; Advanced
Instrument Cluster w/ digital hour meter,
tachometer, fuel level LCD bar graph w/ alarm,
DEF Level, diagnostic features and security lockout;
Mechanical hand controls.

Warning lights with alarms:
Engine coolant temperature; Engine oil pressure;
Engine malfunction; Hydraulic charge pressure;
Hydraulic filter restriction; Hydraulic oil
temperature: Critical system stop, Engine
system, Hydraulic system, Electrical and
diagnostic system.

Warning alarms:
Battery voltage – plus display; Diesel Exhaust
Fluid – DEF; Oil service.

Indicator light:
Engine preheat; Parking brake;
Seat bar reminder.

OPERATING WEIGHT

Unit equipped w/ open cab; 165 lb operator; 78 in Heavy-Duty bucket; full of fuel; 14 x 17.5 tires:	9,100 lb (4 136 kg)
Shipping weight	8,557 lb (3 890 kg)

Add-on weights:	
Side cab glass	47 lb (21.3 kg)
Polycarbonate cab door	75 lb (34.0 kg)
Glass cab door w/ wiper	75 lb (34.0 kg)
Suspension seat	22 lb (10.0 kg)
Additional counterweight	300 lb (136.0 kg)

HYDRAULICS

Implement pump type	Gear
Displacement:	
Standard aux.	2.23 in ³ (36.6 cm ³)
High-flow aux.	1.42 in ³ (23.3 cm ³)

Standard flow @ rated engine RPM: @ 100% efficiency	24.2 gpm (91.5 L/min)
--	-----------------------

Optional high-flow @ rated engine RPM: @ 100% efficiency	38.7 gpm (146.5 L/min)
---	------------------------

Enhanced high-flow @ rated engine RPM: @ 100% efficiency	35.0 gpm (132.5 L/min)
---	------------------------

Loader control valve:	
Type	3 spool/open center/series - series
Relief pressure	3,450 psi (238 bar)

Port relief pressures:	
Loader raise	3,625 psi (250 bar)
Bucket curl	3,916 psi (270 bar)
Bucket dump	3,625 psi (250 bar)

Hydraulic lines:	
Tubing	ORFS + 37° JIC Flare
Loop hoses	SAE 100 R19

HYDRAULICS CONT.

Hydraulic oil cooler:

Number of fins	10 per inch (3.94 per cm)
Number of tube rows x columns	9 bar/plate
Area	138.7 in ² (890 cm ²)

Hydraulic filter Beta (4) = 75/spin-on

Lift cylinders:

Bore diameter	2.75 in (69.85 mm)
Rod diameter	2.0 in (50.8 mm)
Stroke	34.9 in (886.5 mm)
Closed length	47.4 in (1 205 mm)

Bucket cylinders:

Bore diameter	3.0 in (76.2 mm)
Rod diameter	1.5 in (38.1 mm)
Stroke	15.7 in (398 mm)
Closed length	24.0 in (610 mm)

SERVICE CAPACITIES

Fuel tank 25.5 gal (96.5 L)

Engine oil w/ filter 8.9 qt (8.5 L)

Hydraulic system:

Reservoir	6.0 gal (22.7 L)
Total	12.0 gal (45.4 L)

Chain tanks – per side 5.9 gal (22.2 L)

Diesel Exhaust Fluid (DEF) Tank 2.8 gal (10.7 L)

PERFORMANCE SPECS

Rated operating capacity – ROC*:

50% of tipping load	3,400 lb (1 545 kg)
w/ additional counterweight	3,650 lb (1 656 kg)

Tipping load* 6,800 lb (3 090 kg)

Breakout forces @ 3,150 psi (217 bar)*:

Bucket cylinders	9,531 lb (42.4 kN)
Lift cylinders – tip limit	6,816 lb (30.3 kN)

Cycle times:

Raise	4.6 sec
Lower	3.5 sec
Dump	2.6 sec
Roll back	2.0 sec

NOTE: *Measured using 78 in (1.98 m) dirt and foundry bucket.

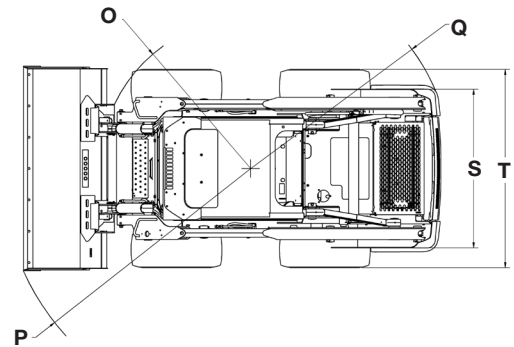
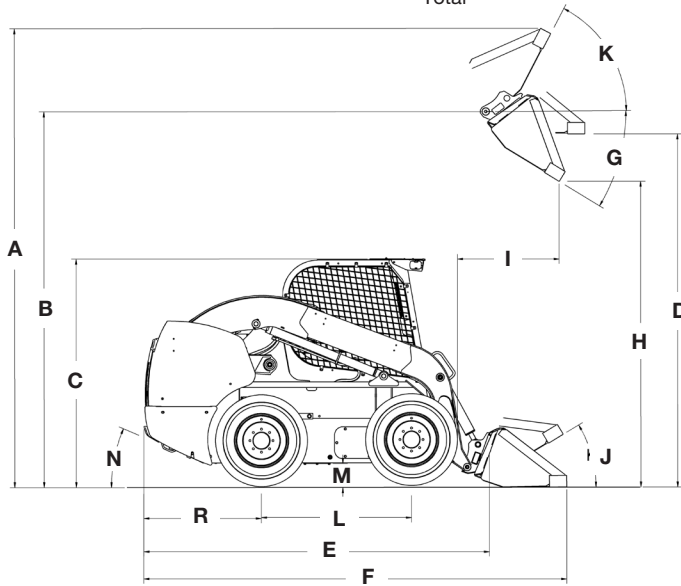

Line drawings are for illustrative purpose only and may not be exact representation of unit.

DIMENSIONS

A. Overall operating height:

with foundry/excavating bucket	161.9 in (4.11 m)
with low profile bucket	166.2 in (4.22 m)
with low profile extended bucket	171.0 in (4.34 m)

Height to:

B. Bucket hinge pin	131.6 in (3.34 m)
C. Top of ROPS	80.4 in (2.04 m)
D. Bottom of level bucket, fully raised	124.8 in (3.17 m)

Overall length:

E. without attachment with coupler	119.1 in (3.02 m)
F. with foundry/excavating bucket on ground	144.3 in (3.67 m)
with low profile bucket	148.5 in (3.77 m)
with low profile extended bucket	153.4 in (3.89 m)

G. Maximum dump angle

46.7°

H. Dump height:

with foundry/excavating bucket	105.2 in (2.67 m) @ 45°
with low profile bucket	102.2 in (2.59 m) @ 45°

I. Dump reach at maximum height with low profile bucket

27.2 in (0.69 m) @ 45°

Maximum attachment rollback:

J. Bucket on ground	35.0°
K. Bucket at full height	86.2°

L. Wheelbase

52.0 in (1.32 m)

M. Ground clearance – bottom of belly pan

9.6 in (0.24 m)

N. Angle of departure

26.5°

Clearance circle:

O. without bucket	56.4 in (1.43 m)
P. with 72 in (1.83 m) foundry/excavating bucket in carry position	85.2 in (2.17 m)
with 72 in (1.83 m) low profile bucket on ground	89.0 in (2.26 m)
with 72 in (1.83 m) extended low profile on ground	93.4 in (2.37 m)

Q. Clearance circle rear

71.2 in (1.80 m)

R. Rear axle to bumper

42.4 in (1.08 m)

S. Tread over gauge with spec tires

60.2 in (1.53 m)

T. Over the tire width spec tires

73.8 in (1.88 m)

OPTIONAL BUCKETS

Type	Width	Weight	Heaped Capacity
Dirt & Foundry	72 in (1.83 m)	420 lb (190 kg)	16.2 ft ³ (0.46 m ³)
	78 in (1.98 m)	440 lb (200 kg)	17.7 ft ³ (0.50 m ³)
Low Profile	72 in (1.83 m)	480 lb (218 kg)	14.8 ft ³ (0.42 m ³)
Low Profile Extended	72 in (1.83 m)	510 lb (232 kg)	17.7 ft ³ (0.50 m ³)
	78 in (1.98 m)	540 lb (245 kg)	19.1 ft ³ (0.54 m ³)
	84 in (2.13 m)	575 lb (262 kg)	20.5 ft ³ (0.58 m ³)
Light Material	72 in (1.83 m)	475 lb (216 kg)	23.3 ft ³ (0.66 m ³)
	84 in (2.13 m)	540 lb (245 kg)	27.5 ft ³ (0.78 m ³)
Manure & Slurry	72 in (1.83 m)	480 lb (218 kg)	19.1 ft ³ (0.54 m ³)
Heavy-Duty	72 in (1.83 m)	510 lb (230 kg)	14.1 ft ³ (0.40 m ³)
	78 in (1.98 m)	530 lb (240 kg)	15.5 ft ³ (0.44 m ³)
	84 in (2.13 m)	550 lb (250 kg)	17.0 ft ³ (0.48 m ³)
Heavy-Duty Extended with SmartFit Teeth	72 in (1.83 m)	667 lb (303 kg)	17.4 ft ³ (0.49 m ³)
	78 in (1.98 m)	697 lb (316 kg)	18.9 ft ³ (0.54 m ³)
	84 in (2.13 m)	728 lb (330 kg)	20.5 ft ³ (0.58 m ³)

STANDARD EQUIPMENT

OPERATOR ENVIRONMENT

See page 1

ENGINE

Charged Air Cooler (CAC)
Dual element air cleaner
Organic Acid Technology (OAT)
Anti-freeze solution to -34° F
Fuel tank – 25.5 gal (U.S.)
Over and under radiator and oil cooler
3-stack after cooler/radiator/oil cooler configuration
Glow plugs
Integral engine oil cooler
Fuel filter with water trap
1,000 CCA 12V battery
Master electrical disconnect
Jump start terminal

DRIVETRAIN

2-speed hydrostatic four wheel drive
ASA #100HS drive chain
SAHR disc parking brake

OPTIONAL EQUIPMENT

OPERATOR ENVIRONMENT

Enclosed cab:
Fully sealed and pressurized – FSP
Glass door with wiper and washer
Sliding side windows – removable
Heater and air conditioner
AM/FM Bluetooth radio with 2 speakers
Keyless start ignition
8 in Color LCD Display
Economy Mode (auto idle shutdown)
Auto Engine Protection Shutdown
Electro-hydraulic controls:
For drive/steering, loader functions
Switchable between H and ISO patterns
Adjustable sensitivity of controls
Hand and foot controls:
Hand controls the loader drive function
and foot controls the bucket and boom
Air ride seat
Demolition cab door with polycarbonate
Ignition Timeout
Machine Settings User Access Levels
Operator Security Codes
Auto Idle setting

HYDRAULICS

Auxiliary hydraulics:
@ 3,450 psi (238 bar) – 24.2 gpm
(91.5 L/min)
6 micron oil filtration system
3-spool loader control valve
Auxiliary hydraulic disconnects, ISO
flat-face – connect-under-pressure
with case drain
Hydraulic circuit pedal lock
Auxiliary function lockout override
Loader lift lockout override
Heavy-duty hydraulic oil cooler
Loader arm float position
Connect under pressure auxiliary
hydraulic disconnects

LOADER

Auxiliary front electric control
Heavy duty hydraulic attachment coupler
Vertical lift geometry
Loader lift arm support strut
In-cab loader lock

HYDRAULICS

High-flow auxiliary hydraulics – combined:
@ 3,450 psi (238 bar) – 38.7 gpm
(146.5 L/min)
Enhanced High-Flow auxiliary hydraulics – EHF:
@ 4,000 psi (276 bar) – 35.0 gpm
(132.5 L/min)
Second auxiliary hydraulics
Hydraulic one-way self-leveling
Ride control

LOADER

Hydraulic attachment coupler

DRIVETRAIN

Creep Speed Mode (on EH machines only)

OTHER

Language decals
Buckets – see page 3
Bolt-on bucket cutting edges
Special paint
Offsite service arrangement

TIRES

14 X 17.5 Heavy duty

OTHER STANDARD FEATURES

LED lights – 2 front, 2 side, 2 rear flood
Pre-wired for rotating beacon
Lockable service access hood
Single-point daily service
Rear tail lights
Remote oil and fuel filters
Block heater
Debris ingress sealing
Mounting points for add-on counterweights
Deluxe cloth, air suspension seat

TELEMATICS

CASE SiteWatch™ Telematics – includes
hardware and a 5-yr data subscription
SiteConnect Module providing remote
diagnostics capability

FACTORY SUPPLIED ATTACHMENTS

Rotating beacon
Four point lift hook
48 in (1.22 m) pallet forks

SERVICE PARTS

Add-on counterweights
Road lights
Four-corner LED strobe
Single point lift hook
Aspirator
Precleaner
3 inch (76.2 mm) retractable seat belt
Bolt-on heavy-duty bucket teeth

CaseCE.com

©2023 CNH Industrial America LLC. All rights reserved. CASE is a trademark registered in the United States and many other countries, owned by or licensed to CNH Industrial N.V., its subsidiaries or affiliates. CNH Industrial Capital is a trademark in the United States and many other countries, owned by or licensed to CNH Industrial N.V., its subsidiaries or affiliates. Printed in U.S.A. Contains 10% post-consumer fiber.

IMPORTANT: CASE Construction Equipment Inc. reserves the right to change these specifications without notice and without incurring any obligation relating to such change. Availability of some models and equipment builds vary according to the country in which the equipment is used. The illustrations and text may include optional equipment and accessories and may not include all standard equipment. Your CASE dealer/distributor will be able to give you details of the products and their specifications available in your area.



CASE Construction Equipment is biodiesel-friendly. NOTE: All engines meet current EPA emissions regulations. All specifications are stated in accordance with SAE Standards or Recommended Practices, where applicable.



Always read the Operator's Manual before operating any equipment. Inspect equipment before using it, and be sure it is operating properly. Follow the product safety signs and use any safety features provided.

Form No. CCE202310SV340B
Replaces Form No. CCE202009SV340B

SV340B

4 of 4