

M-SERIES CRAWLER DOZERS
2050M

CASE
CONSTRUCTION



TECHNOLOGY
THAT PAYS

caseCE.com
EXPERTS FOR THE REAL WORLD
SINCE 1842

CASE CRAWLER DOZERS MILESTONES



EXPERTS FOR THE REAL WORLD SINCE 1842

- 1842** Case is founded.
- 1946** Allis-Chalmers is the first manufacturer to introduce a torque converter on dozers. In the 30s they had invented permanently lubricated track rollers and sealed and lubricated tracks.
- 1951** First Case Dozer made in cooperation with ATC and promoted under Terratrack brand.
- 1956** Case acquires ATC and is the first manufacturer to introduce tracks counterrotation on the 1000 Series Terratrack Dozer.
- 1974** FIAT acquires Allis-Chalmers and in the 70s introduces the exclusive “Equistatic” geometry on bulldozer machines. In the late 90s Case launches its exclusive “CASE Extended Life Track” undercarriage.
- 2008** Case introduces the “Dual Path” hydrostatic transmission on the “K” Series.
- 2013** Case is the first to introduce SCR technology on the “M” Series dozer for regulated countries.
- 2014** Case started to build L-Series Dozers in Belo Horizonte plant for not regulated countries.

BOOST YOUR PRODUCTIVITY

POWER AND EFFICIENCY

Drawbar pulling leadership: the hydrostatic transmission and the common rail engine deliver best-in-class pulling capacity and controllability. All the working parameters can be customized by the driver for excellent machine controllability and faster cycle times. Productivity boosting electronics: the new cab controls offer a wide choice of electronic settings and automated functions that make the driver's job easier. Together with the lowest noise level in the market, they minimise fatigue on long working days. Customise your dozer: the M-Series offers a wider choice of attachments such as blades, tracks, rippers, or winches. You can easily specify the configuration that perfectly meets your needs. Quick maintenance: the fully openable side panels enable you to service the M-Series from the ground, while the wide belly plates provide perfect accessibility for extraordinary maintenance.

NEXT GENERATION ENGINE

The state of the art common rail engine delivers top performance in load response, max torque, power and fuel economy. The combustion is optimised for maximum efficiency, occurring at high temperatures and using 100% fresh, cool air, as the air intake is separated from the exhaust.

The turbocharged engine with an Air-to-Air intercooler relies on well proven multi injection technology to maximize torque back-up and fuel efficiency with reduced engine noise and vibrations.



NEVER ENDING POWER

The powerful FPT Industrial engine ensures high torque back-up under load. When the tractive effort grows and the rpm tends to drop, the engine power grows up to 16% till 1800 rpm. The result is constant performance and higher pulling capacity. In addition, the ability to work with high torque at lower engine rpm reduces engine wear.



DRAWBAR PULLING LEADERSHIP

DUAL PATH HYDROSTATIC TRANSMISSION

The entirely re-engineered transmission offers best-in-class pulling capacity combined with the typical manoeuvrability of the hydrostatic solution. The triple reduction final drives ensure high torque on the ground, reducing the working pressure of the entire system and improving its overall efficiency.



“V” SHAPE COOLING PACKAGE

The cooling package of the 2050M has been redesigned and fitted with a hydrostatic reversible fan. In the new design, the radiators are mounted with no overlap, so that each radiator receives fresh air, maintaining constant fluid temperatures. The hydrostatic fan continuously adapts its speed to match the real cooling demand, reducing power absorption. The reversing mode reduces maintenance needs and lengthens cleaning intervals.

CASE EXTENDED LIFE TRACKS

The CASE Lubricated Track (CLT), standard on 2050M, is sealed and lubricated with an oil reservoir in each pin. For long wear life, pins and bushings are sealed to keep the contamination out while maintaining lubrication. In abrasive soil conditions, the exclusive CASE Extended Life Track (CELT) provides outstanding durability. CELT uses a second, hardened bushing that is free to rotate on the standard bushing, allowing wear to be distributed over the entire circumference of the outer bushing. In addition the sprocket is made with 40% more material, extending the life of its teeth. When you consider that maintenance of the undercarriage represents on average 50% of a dozer’s maintenance costs, the Case solution brings a clear benefit for the most demanding customers.



PRODUCTIVITY BOOSTING ELECTRONICS



AGILE AND STRONG

The operator has full control of the massive power of the M-Series Dozer. The electrohydraulic joystick allows to customize the reversing and steering sensitivity for faster and more efficient cycles. The decelerator pedal can be used either to reduce the travel speed only or travel and engine speed.



AUTOMATIC BLADE FUNCTIONS

The advanced electronics functions enable the operator to specific functions in addition to the standard blade movements. The on-board computer can be set directly from the joystick; the blade reaction can be set choosing from 3 levels of sensitivity; the grading button immediately reduces the speed of the blade by 50% for more accurate soil contour; the shaking mode enables the operator to shed material quickly, especially when working with sticky soil.



UNMATCHED VISIBILITY

The M-Series cab is engineered for operator performance, comfort and safety. The new positioning, further forward on the machine, ensures complete blade visibility. The operator can work with confidence and more productively in every operation. The air suspended seat is easy to adjust, providing every operator with a perfect working position. The powerful air conditioning system combined with the best-in-class noise level provide an excellent working environment, reducing operator stress during long working days.

CUSTOMIZE YOUR DOZER

FULLY INTEGRATED BLADE CONTROL

The M-Series is ready to work with the most common blade controls available on the market. The machine can be prepared in the factory for a specific configuration, ensuring perfect wire layout, visibility and component integration, guaranteeing the high standards of reliability of every Case product are maintained.



READY FOR EVERY TASK

A wide offering of implements and equipments can be installed on the new CASE Dozers:

- Drawbar
- 3 shanks parallel ripper
- Front cab protections and grids
- Winches predisposition

Two blades are available for optimum dozing performance:

- PAT (Power Angle Tilt)
- Bulldozer Semi-U

All Case Bulldozers offer the patented «Equistatic» system that increases the tilting capability, while reducing the efforts on the pushbeams, increasing the overall frame reliability and reducing the overall wear of components.



***EASY ACCESS
WITH THE TILTABLE SEAT***



SIMPLE AND EASY

The hydrostatic transmission brings less complexity and lower maintenance requirements than a traditional one. Belly plates on the bottom of the machine provide excellent access to controls and transmission components. The final drive installation on the main dozer frame enables dismounting while leaving the hydrostatic components in place. The transmission can even be reached through the cab floor, so it can be serviced directly on the jobsite.



FAST REFUELING

The refueling points (Fuel/Hydraulic Oil) are conveniently placed on the rear of the cab in a well-protected place. The daily maintenance can be done quickly thanks to dedicated steps that make the access easier and safer.



GROUND ACCESS FOR SERVICING

The new single piece main frame enables you to service the main controls easily from the ground, simply opening the wide lateral shieldings. Oil levels, battery status, electric components, filters and the emergency cut-off switch are rationally grouped and clearly identified with colour coding. With the M-Series, you can quickly get ready for your working day.



M-SERIES CRAWLER DOZERS

ENGINE

Model	FPT Industrial Engine F4HFA613N Tier 2 regulations
Cylinders	6
Displacement	6,7 L
Fuel injection	Direct common rail
Fuel filter	Scr-on, with screen
Air in take	Cross-flow
Cooling	Liquid
Engine speeds	RPM
High idle - no load	2200 +/- 50
Rated - full load	2200
Low idle	800 +/- 25

Horsepower SAE J1349

Net	214 hp (160 kW) @ 2200 rpm
Gross	232 hp (173 kW) @ 2200 rpm

Engine lubrication

Pump	Deep sump plate cooler w/ pressurized under-piston nozzles
------	---

Pump operating angle ratings

Side-to-side	35°
Fore and aft	45°

Radiator

Core size area	0.33 m ²
Rows of tubes	2

Fan

Diameter	700 mm
Ratio	hydraulically driven

TRANSMISSION COOLING

Type	Oil to air
Core size	0.31 m ²

ELECTRICAL SYSTEM

Alternator	120 amps
Batteries(2)	12 Volt, low maintenance 1000 cold-cranking amps @ -18°C

POWER TRAIN

Dual path hydrostatic

Pump	Variable axial piston
Motor	Variable bent axis piston
Max. drawbar pull	360 kN
Transmission	Single lever control electronic straight tracking
Oil filter	4 micron, spin-on, replaceable

Travel speeds

Forward	0 - 9.3 km/h
Reverse	0 - 9.3 km/h

Parking brakes Heavy-duty
(Spring Applied Hydraulically Released)

Steering brakes	Hydrostatic
-----------------	-------------

Final drive	2 helical gear reductions to planetary
-------------	---

Ratio	48.75:1
-------	---------

BLADE

Variable blade pitch - adjustable	55° +/- 5°
Lift speed - per second	483 mm
Cutting edge	Reversible, replaceable
Width (PAT)	254 mm
Width (Bulldozer HSU)	200 mm
Thickness	20 m

RIPPER

Max. penetration	581 mm
Width	2159 mm
Cut width	1938 mm
Max. ground clearance	518 mm
Max. number of shanks	3
Tooth spacing w/3 teeth	930 mm
Hydraulic cylinder	Double-acting
Diameter	133.4 mm
Stroke	597 mm
Rod	70 mm

OPERATOR ENVIRONMENT

ROPS/FOPS cab - pneumatically suspended seat - w/ back adjustment - seat belt - adjustable armrests - foot rests - tool storage area - headliner floor mat - tilting seat platform - noise level 78dbA.

Warning lights - air filter - alternator - diagnostic fault indicator - engine coolant temperature - engine oil pressure - hydraulic filter - low fuel level - park brake engaged - service soon indicator - transmission filter - transmission charge pressure.

Gauges

Battery voltage - digital hour meter/tachometer diagnostic/service reminder - fuel level - transmission oil temperature - transmission speed indicator - water temperature.

Audible warnings - engine coolant temperature - engine oil pressure - low fuel level - transmission charge pressure - transmission/hydraulic temperature.

HYDRAULICS

Pump flow @ 2200 RPM	153 L/min
Max pressure	248 bar
Lift cylinder PAT	nr.2
Bore diameter	114 mm
Rod diameter	63.5 mm
Stroke	428.8 mm
Angle cylinder PAT	nr.2
Bore diameter	114.3 mm
Rod diameter	63.5 mm
Stroke	502.7 mm
Tilt cylinder PAT	nr.1
Bore diameter	127 mm
Rod diameter	63.5 mm
Stroke	148.4 mm

Lift cylinder Bull Dozer

Bore diameter	82.6 mm
Rod diameter	50.8 mm
Stroke	1000 mm

Tilt cylinder Bull Dozer

Bore diameter	114.3 mm
Rod diameter	63.5 mm
Stroke	126 mm

TRACK AND SHOE OPTIONS

XLT (EXTRA LONG TRACKS)

610 mm	closed grousers and CLT
610 mm	open grousers and CELT

SERVICE CAPACITY

Fuel Tank	405 L
Engine oil w/ filter	16.4 L
Engine oil w/o filter	15.6 L
Engine cooling system	30.28 L
Hydraulic reservoir	210 L
Final drive - per side	25 L
Track rollers - each	0.275 L
Front idlers - each	0.225 L
Carrier rollers - each	0.334 L

OPERATING WEIGHT

Operating weight includes:

Cab	Front pull hook
Full fuel tank	Rear retrieval hitch
Hydraulic tanks	Track guides
Operator	170 lb (77 kg)
CLT chain	Horn
Lights	Track shoe
C - frame	Blade width as noted

WEIGHT (KG)

Extra Long Tracks	20599 kg PAT 20592 kg Semi-U
-------------------	---------------------------------

ADD-ON WEIGHTS

Drawbar	66
Ripper (3 shank)	1355
Winch	2500

CELT CHAIN - PER TRACK

24" (610 mm)	1789
Additional weight vs CLT - per track	43
Center rock guard	306
Sweeps	63

UNDERCARRIAGE

Track adjustment	Grease injection
Frame	Oscillating equalizer beam suspension and pivot shaft

Track link pitch

CLT track	202.8 mm
CELT track	202.8 mm
Track shoe height	73 mm
Pin diameter	44.5 mm

Bushing diameter

CLT track	72.7 mm
CELT track	93 mm

Track shoes per side

CLT/CELT track	45
Track rollers per side	8
Carrier rollers per side	2
Track roller rail diameter	187.6 mm

TRACK ON GROUND

Shoe area	
610mm	39979 cm ²

SPECIFICATIONS

2050M

GENERAL DIMENSIONS

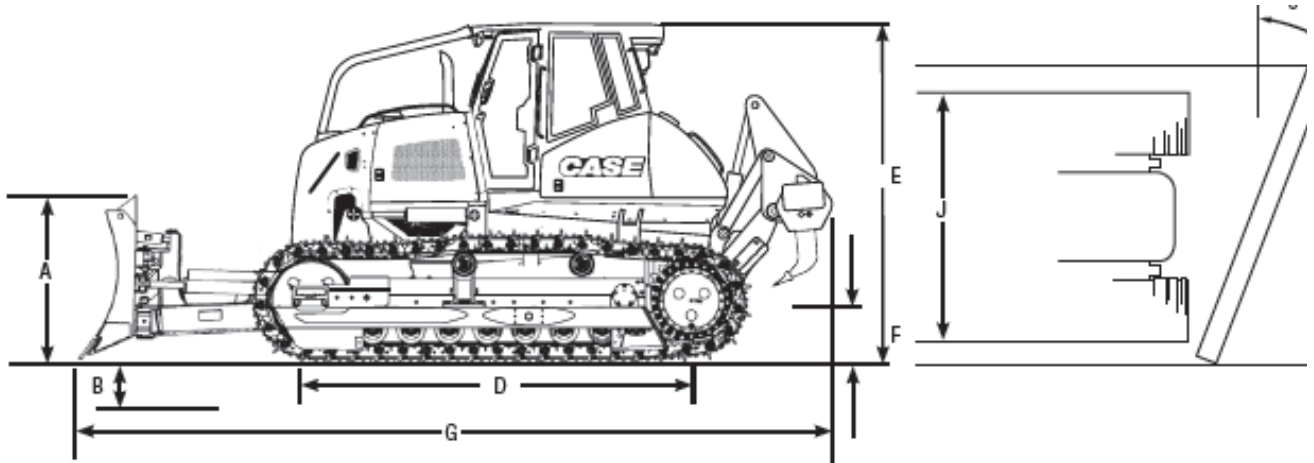

Line drawings are for illustrative purpose only and may not be exact representation of unit.

XLT (extra-long track)

TRACKS

Track gauge	1940 mm
Max shoe width	610 mm
D. Track on ground	3277 mm
Area of track of ground	4,0 m ²
Ground pressure	0.51 kg/cm ²

DIMENSIONS

E. Height to top of cab	3103 mm
F. Ground of clearance	362 mm
G. Length	
Blade straight with drawbar	5902 mm PAT 5387 mm Semi-U
Blade straight with ripper	7383 mm PAT 6869 mm Semi-U

BLADE DIMENSIONS

	SEMI - U	PAT
Blade Capacity SAE J1265	5.60 m ³	4.83 m ³
Undercarriage available	XLT	XLT
H. Blade width	3426 mm	3606 mm
Blade width in transport position	3426 mm	3287 mm
A. Blade height	1425 mm	1369 mm
Max. Tilt	+/- 433 mm	+/- 550 mm
Max. Pitch	+/- 5°	+/- 5°
C. Max. Angle	-	+/- 28°
B. Digging depth	583 mm	590 mm
Max lift above ground	1244 mm	1130 mm
M. Cast reach	438 mm	576 mm
N. Cut reach	438 mm	146 mm
J. Over track	2550 mm width 610 mm shoes	2550 mm width 610 mm shoes

NOTE: Ground clearance and overall height dimensions are with the grousers fully penetrated. Add 52.5 mm if unit is on solid surface.

STANDARD AND OPTIONAL

STANDARD

ENGINE

FPT Industrial engine NEF Family
Integral engine oil cooling
Fuel filter
Dual element radial seal air cleaner
120 amp alternator
2 x 12 V batteries
Engine side panels

BLADE

50° - 60° variable pitch with integral adjustment tool
Single lever electro-hydraulic control for blade lift, angle, or tilt "Equistatic" device for bull dozer version

POWER TRAIN

Dual path infinitely variable, single-lever
Controlled hydrostatic drive with electronic straight tracking and counter-rotation
Forward/reverse ratio control
3 pre-selectable steering sensitivities
3 reversing sensitivities
3 blades sensitivities
Blade Shaking Mode
Fine grading mode
Triple reduction final drive: helical gear/planetary
Decelerator with hydrostatic drive retardation
Automatic spring applied parking brake

UNDERCARRIAGE

Hydraulic track adjusters
Case Lubricated Track (CLT) Chain
Permanently lubricated track and carrier rollers/idlers
Track adjuster guard
Track guides - front and rear

OPERATOR ENVIRONMENT

Cab with heater, A/C, defroster, windshield wiper and lights
Seat belt
76 mm Internal mirror

OTHER

Backup alarm
Horn
Lights: 2 front 1 rear
Master disconnect switch
Mirror
Rear transmission guard

OPTIONS

REAR MOUNTED EQUIPMENT

Ripper - 5 position with 3 shanks
Rear tow hook
Rear drawbar

HYDRAULICS

4 spool hydraulic valve for field-installed ripper
3 spool hydraulic valve without plugs for field-installed ripper
3 spool hydraulic valve with plugs

GUARDS

CAB canopy brush guard
Center rockguard
Sweeps

BLADES

PAT 3.60 m
Semi-U 3.42 m

SCREENS

Cab rear screen
Radiator brush screen

OPERATOR ENVIRONMENT

Environmental drain
Case Extended Life Track Chain
Grid heater
Additional work lights
Front pull hook
Blade guidance ready for: Leica/Topcon/Trimble
Rearview mirror
Rear wiper for cab
Radio

Standard and optional equipment shown can vary by country.

CaseCe.com
EXPERTS FOR THE REAL WORLD
SINCE 1842

CASE
CONSTRUCTION



PARTS

Wide network of customer support across the world. No matter where you work, we're here to support and protect your investment and exceed your expectations. You can count on Case and your Case dealer for full-service solutions-productive equipment, expert advice, flexible financing, genuine Case parts and fast service. We're here to provide you with the ultimate ownership experience. To locate a Case dealer or learn more about Case equipment or customer service, go to www.casece.com

NOTE: CASE provides specific outfits for various countries and many optional fittings (OPT). The illustrations on this or other leaflets may relate to standard or optional fittings. Please consult your CASE dealer for any information in this regard and any possible updating on components. CNH Industrial reserves the right to modify machine specifications without incurring any obligation relating to such changes.

