



ENGINE

Model	FPT F5BFL413B*B
Emissions Certification	Tier 4 Final
Type	Diesel 4-stroke, Turbocharged
Cylinders	4
Bore/Stroke	3.90 x 4.33 in (99 x 110 mm)
Displacement	207 in ³ (3.4 L)
Fuel injection	Direct, high pressure common rail – HPCR
Fuel	Diesel
Engine speeds*	RPM
Rated speed – full load	2200
Low idle	900 – 1000
High idle – no load	2330 – 2430
Horsepower @ 2200 RPM:	
Gross	97 hp (72 kW)
Net	95 hp (71 kW)
Maximum torque @ 1400 RPM:	
Gross	334 lb-ft (453 N-m)
Net	333 lb-ft (452 N-m)
Torque rise at rated speed	45% +/- 5%
Radiator:	
Core type	Square wave
Core size area	486 in ² (3 145 cm ²)
Rows of tubes	4
39° fan:	
Style	9 blade suction
Diameter	19.65 in (499 mm)
Ratio**	1.4:1
Pump operating angle ratings:	
Side to side	Rated 35°
Fore and aft	Rated 35°
Oil filtration	Replaceable, full flow cartridge

NOTE: *Engine speeds w/ standard transmission.
Meets federal emission regulations.
**Viscous fan.

DRIVETRAIN

Transmission – standard:
4F-4R Power Shuttle Synchromesh Transmission
manual gear shift, fully synchronized

Specifications below apply to the Power Shuttle
transmission.

Gear ratios	Forward/Reverse
1st	5.603/4.643
2nd	3.481/2.884
3rd	1.584/1.313
4th	0.793/0.657

Travel speeds – Standard Power Shuttle

Transmission	Forward mph (kph)	Reverse mph (kph)
1st	3.4 (5.5)	4.1 (6.6)
2nd	5.5 (8.9)	6.6 (10.7)
3rd	11.8 (19)	14.2 (22.8)
4th	22.5 (36.2)	27 (43.4)

Transmission – optional:
Powershift H-Type, 4F-3R hydraulic clutch
shifting w/ auto shift mode

Gear ratios	Forward/Reverse
1st	5.533/4.549
2nd	3.359/2.762
3rd	1.533/1.260
4th	0.811/—

Travel speeds – Optional H-Type Powershift

Transmission:	Forward mph (kph)	Reverse mph (kph)
1st	3.5 (5.6)	4.2 (6.7)
2nd	5.7 (9.1)	6.8 (10.9)
3rd	12.1 (19.4)	14.5 (23.3)
4th	22.1 (35.5)	—

Torque converter ratio	2.38
------------------------	------

Differential-lock:
On-the-go push-button activation

Front/Rear axle:	
Differential ratio	2.29/2.75
Planetary hub ratio	6.0/6.4
Total reduction ratio	13.7/17.6

Service brakes:
Individually applied, power assisted,
hydraulically actuated, maintenance-free,
self-adjusting, outboard mounted, wet disc,
2 per side.
Total disc area 384 in² (0.25 m²)

Parking brakes	Trans Mounted spring-applied hydraulic release – SAHR
----------------	--

NOTE: Travel speeds w/ 19.5 L x 24.0 tires.

ELECTRICAL

Voltage	12 Volts, negative ground
Alternator	160 amp
Single Battery	900 amp
Power plugs – 1	20 amp

OPERATOR ENVIRONMENT

ROPS/FOPS certified protective cab; 2 door w/
heat, A/C, defroster, floor mat, Bluetooth radio,
front and rear wiper; Interior rearview convex
mirror; Mechanical suspension deluxe seat; 2 in
(50 mm) retractable seat belt; Cup holder and
storage trays positioned on the right side; and
enclosed storage compartment on left side.

Gauges:
Engine coolant temperature; Converter oil
temperature; Fuel level; Tachometer/
hourmeter; DEF level.

Warning lights:
Air cleaner restriction; Alternator; A/C high
pressure; Cold start; Engine oil pressure;
Hydraulic oil filter bypass; Parking brake
engagement; Low fuel; Water in fuel; Low DEF.

Audible alarms w/ diagnostics:
Coolant temperature; Engine oil pressure;
Parking brake engagement; Converter oil
temperature; Shuttle engagement/seat
position; Backup alarm; Low DEF.

Horn	Dual switched front and rear
------	------------------------------

OPERATING WEIGHT

Configuration 1:

Cab, HVAC, 15' in-line cylinder backhoe w/
Extendahoe, 4 in 1 loader bucket with cutting
edge, medium counterweight, 24" HD backhoe
bucket, Front Wheels 14 x 17.5 Rear Wheels
21L x 24, ride control and operator.
18,717 lb (8 490 kg)

Configuration 2:

Cab, HVAC, 14' overlapping cylinder backhoe
w/ Extendahoe, 6 in 1 loader bucket with
cutting edge, large counterweight, 24" HD
backhoe bucket, Front Wheels 14 x 17.5, Rear
Wheels 21L x 24, ride control and operator.
19,600 lb (8 890 kg)

HYDRAULICS

Pump:

Sauer Danfoss Variable Displacement Axial Piston Pump	
Flow Ratings	36 gpm @ 2,973 psi (136 L/min @ 205 bar)

Main relief pressure:

2,973 +/- 44 psi (205 +/- 3 bar)

Filtration:

7-micron, full flow replaceable cartridge on return line, condition indicator light for filter.

Oil cooler	Heavy-duty
------------	------------

Loader control valve:

Two or three spool sectional valve. The two spool valve has single lever control for lift and tilt. The three spool valve has a pilot controlled clam valve. The lift lever has positive hold "float" position and "return to dig" feature. Valve is post compensated with flow sharing. Valve allows simultaneous operation of loader lift and loader bucket.

Backhoe flow @ 2200 RPM:

Maximum backhoe flow for 1-way hydraulics:
36 gpm @ 2,973 psi
(136 L/min @ 205 bar)

Pilot backhoe control valve:

Six, seven, or eight spool sectional closed center control valve. Basic control valve is closed center, w/ circuits in parallel w/ a post-compensated, flow sharing feature for simultaneous operation of all circuits.

1-way flow auxiliary hydraulics:

1-way flow hydraulic valve is equipped with a variable flow feature adjustable at the valve.

Actuation:

Pilot controls – left-hand joystick/pedal.

2-way flow auxiliary hydraulics:

2-way flow hydraulic valve.

Actuation:

Left-hand joystick.

Combined auxiliary hydraulics:

Combined 1-way/2-way auxiliary hydraulics.

SERVICE CAPACITIES

Fuel tank	34.6 gal (131 L)
-----------	------------------

DEF tank	3.5 gal (13.2 L)
----------	------------------

Hydraulic system:

Total	37 gal (142 L)
-------	----------------

Transmission – total system:

4WD Standard	22 qt (20.8 L)
--------------	----------------

Standard front axle:

4WD Differential	1.7 gal (6.5 L)
------------------	-----------------

Rear axle:

Differential and planetaries	5.6 gal (21.2 L)
------------------------------	------------------

Engine oil w/ filter	8.5 qt (8.0 L)
----------------------	----------------

OTHER SPECIFICATIONS

Front tires:

14 L x 17.5, 10-ply rating
12.5/80 x 18.0 10-ply rating

Rear tires:

19.5 L x 24.0, 10-ply rating
16.9 L x 28.0, 10-ply rating
21 L x 24.0, 10-ply rating

Turning radius: Curb to Curb:

4WD – disengaged*:

Turning Right	14 ft 7 in (4.44 m)
Turning Left	15 ft 5 in (4.70 m)

NOTE: *Turning radius dimensions curb to curb w/ 12.5/80 x 18.0 front tires and 18.4 x 26.0 R4 rear tires.

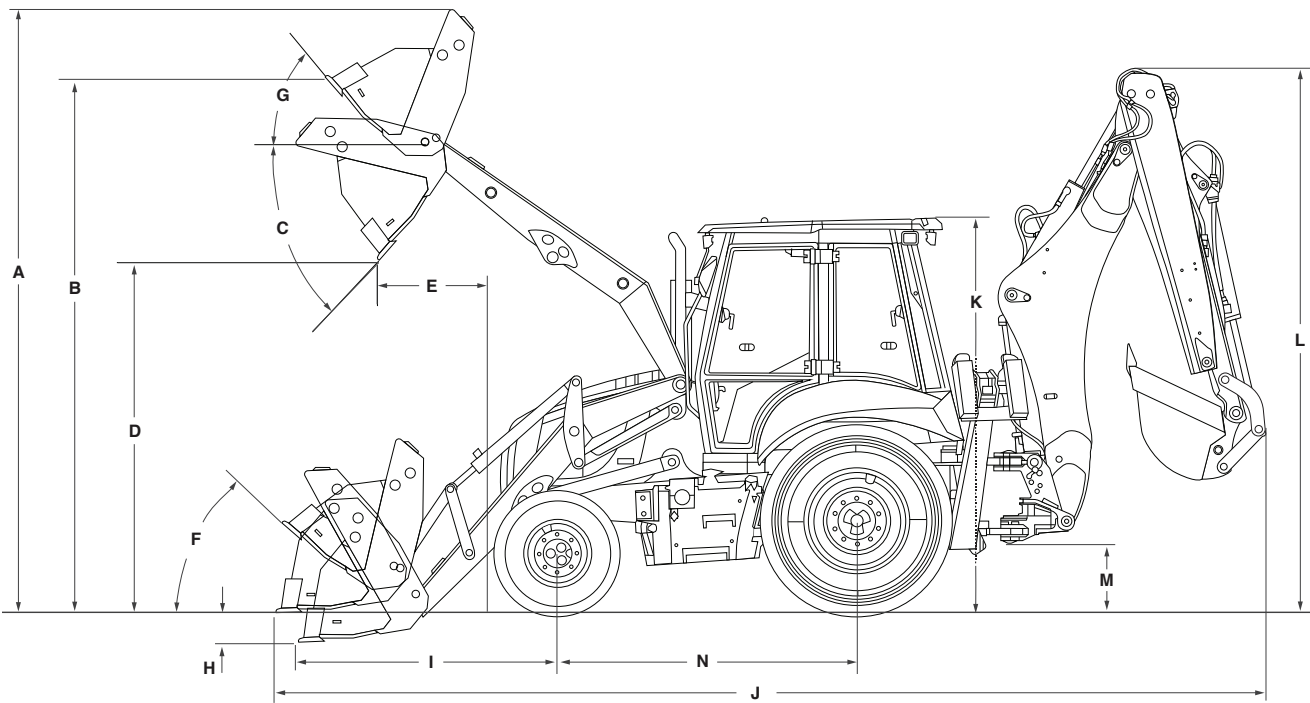

Line drawings are for illustrative purpose only and may not be exact representation of unit.

LOADER DIMENSIONS

	Heavy Duty Bucket	4 IN 1® Bucket
A. Overall operating height – fully raised	13 ft 11 in (4.25 m)	14 ft 5 in (4.38 m)
Height to:		
B. Bucket hinge pin fully raised	11 ft 1 in (3.38 m)	11 ft 1 in (3.38 m)
C. Dump angle at full height	47°	47°
D. Dump clearance at full height, 45° dump: Bucket	10 ft 7 in (3.22 m)	8 ft 4 in (2.55 m)
E. Dump reach at full height, 45° dump – from bumper: Bucket	2 ft 9 in (829 mm)	2 ft 8 in (824 mm)
Bucket rollback:		
F. @ Groundline	42°	42°
G. @ Full height	50°	50°
H. Digging depth below grade: Bucket flat	5.0 in (120 mm)	8.6 in (219 mm)
I. Reach from front axle centerline – bucket on ground	–	6 ft 10 in (2.07 m)
Lift capacity to full height – calculated values	7,606 lb (3 450 kg)	7,044 lb (3 195 kg)
Breakout force:		
Lift cylinders	8,014 lbf (3 565 daN)	8,041 lbf (3 577 daN)
Dump cylinders	14,711 lbf (6 544 daN)	14,950 lbf (6 650 daN)
Raising time to full height	3.4 sec	3.4 sec
Bucket dumping time	2.3 sec	2.3 sec
Lowering time:		
Power down	2.8 sec	2.8 sec
Clam:		
Open time	–	1.9 sec
Close time	–	1.4 sec

NOTE: Loader dimensions taken with 4WD, 14 x 17.5 front tires and 16.9 L x 28.0 rear tires.

DIMENSIONS

	Center Pivot Backhoe with 16.9 L x 28.0 tires
J. Overall transport length: Heavy Duty bucket	23 ft 7 in (7.19 m)
Overall transport width	8 ft 2 in (2.48 m)
Height:	
K. To top of cab	9 ft 5 in (2.86 m)
L. Transport	13 ft 0 in (3.96 m)
M. Ground clearance at backhoe frame	13.4 in (341 mm)
Angle of departure	25°
N. Wheelbase: 16.9 x 28.0 tires	7 ft 2 in (2.18 m)

AXLE RATINGS

	Rear	Front – 4WD
Maximum static	–	46,367 lbf (20 625 daN)
Dynamic operating	16,861 lbf (7 500 daN)	18,546 lbf (8 250 daN)
Static operating	42,152 lbf (18 750 daN)	46,367 lbf (20 625 daN)
Oscillation – front axle	–	22° total – 11° side to side

LOADER BUCKET SIZES

Type	Width	Weight	Struck	Heaped Capacity
Heavy Duty Bucket with bolt-on edge	89 in (2.30 m)	1,042 lb (473 kg)	1.05 yd ³ (0.80 m ³)	1.30 yd ³ (1.00 m ³)
4 IN 1® Bucket with bolt-on edge	89 in (2.30 m)	1,721 lb* (781 kg)	1.05 yd ³ (0.80 m ³)	1.30 yd ³ (1.00 m ³)

NOTE: *Weight of 4 IN 1® bucket includes cylinders and hoses.

BACKHOE BUCKET SIZES

Type	Width	Weight	Heaped Capacity
Heavy Duty	12 in (305 mm)	245 lb (111 kg)	2.8 ft ³ (0.08 m ³)
	18 in (457 mm)	302 lb (137 kg)	4.2 ft ³ (0.12 m ³)
	24 in (610 mm)	348 lb (158 kg)	6.0 ft ³ (0.17 m ³)
	30 in (762 mm)	388 lb (176 kg)	8.1 ft ³ (0.23 m ³)
	36 in (914 mm)	439 lb (199 kg)	9.9 ft ³ (0.28 m ³)
High Capacity Bucket	24 in (610 mm)	388 lb (176 kg)	7.1 ft ³ (0.20 m ³)

BACKHOE LIFT CAPACITIES

In-Line Cylinder Standard Backhoe		In-Line Cylinder Backhoe with Extendahoe®			
		Retracted		Extended	
		14 ft Backhoe	15 ft Backhoe	14 ft Backhoe	15 ft Backhoe
Boom Lift	Lift Capacity lb (kg)	Lift Capacity lb (kg)	Lift Capacity lb (kg)	Lift Capacity lb (kg)	Lift Capacity lb (kg)
+16 ft (4.87 m)	3,574 (1 624)	3,055 (1 389)	3,168 (1 440)	1,844 (838)	2,409 (1 095)
+14 ft (4.27 m)	4,023 (1 829)	3,516 (1 598)	3,729 (1 695)	2,513 (1 142)	2,607 (1 185)
+12 ft (3.66 m)	4,139 (1 881)	3,597 (1 635)	3,828 (1 740)	2,582 (1 174)	2,673 (1 215)
+10 ft (3.05 m)	4,069 (1 850)	3,539 (1 609)	3,784 (1 720)	2,594 (1 179)	2,706 (1 230)
+8 ft (2.44 m)	3,954 (1 797)	3,424 (1 556)	3,454 (1 570)	2,571 (1 169)	2,673 (1 215)
+6 ft (1.83 m)	3,816 (1 734)	3,309 (1 504)	3,245 (1 475)	2,536 (1 153)	2,563 (1 165)
+4 ft (1.22 m)	3,689 (1 677)	3,193 (1 451)	3,135 (1 425)	2,490 (1 132)	2,497 (1 135)
+2 ft (0.61 m)	3,574 (1 624)	3,078 (1 399)	3,080 (1 400)	2,455 (1 116)	2,464 (1 120)
Ground Level	3,470 (1 577)	2,986 (1 357)	3,102 (1 410)	2,409 (1 095)	2,464 (1 120)
-2 ft (0.61 m)	3,366 (1 530)	2,894 (1 315)	3,179 (1 445)	2,375 (1 079)	2,508 (1 140)
-4 ft (1.22 m)	3,297 (1 499)	2,813 (1 279)	3,113 (1 415)	2,352 (1 069)	2,530 (1 150)
-6 ft (1.83 m)	3,239 (1 472)	2,755 (1 252)	3,069 (1 395)	2,329 (1 058)	2,519 (1 145)
-8 ft (2.44 m)	3,228 (1 467)	2,732 (1 242)	3,047 (1 385)	2,329 (1 058)	2,530 (1 150)
-10 ft (3.05 m)	3,343 (1 520)	2,801 (1 273)	3,113 (1 415)	2,363 (1 074)	2,563 (1 165)
-12 ft (3.66 m)	3,574 (1 624)	3,090 (1 404)	3,586 (1 630)	2,467 (1 121)	2,662 (1 210)
-14 ft (4.27 m)	—	—	—	2,859 (1 300)	2,915 (1 325)
Dipper Lift					
+14 ft (4.27 m)	—	—	—	3,613 (1 642)	3,388 (1 540)
+12 ft (3.66 m)	5,545 (2 520)	4,948 (2 249)	4,312 (1 960)	3,935 (1 789)	3,311 (1 505)
+10 ft (3.05 m)	5,330 (2 423)	5,819 (2 645)	4,158 (1 890)	3,875 (1 762)	3,267 (1 485)
+8 ft (2.44 m)	5,437 (2 472)	5,819 (2 645)	4,202 (1 910)	3,923 (1 783)	3,300 (1 500)
+6 ft (1.83 m)	5,962 (2 710)	5,819 (2 645)	4,488 (2 040)	4,102 (1 864)	3,410 (1 550)
+4 ft (1.22 m)	—	5,819 (2 645)	5,324 (2 420)	4,495 (2 043)	3,685 (1 675)
+2 ft (0.61 m)	—	—	—	5,390 (2 450)	4,191 (1 905)

NOTE: Boom and Dipper Lift Capacities are rated per SAE J31 and are 87% of the maximum hydraulic lift force available with the specified options.

BACKHOE OPERATIONAL DATA

	In-Line Cylinder 14 ft Standard Backhoe	In-Line Cylinder 15 ft Backhoe with Extendahoe®		Overlapping 14 ft Backhoe with Extendahoe®	
		Retracted	Extended	Retracted	Extended
Digging depth:					
Maximum	14 ft 5 in (4.40 m)	15 ft 1 in (4.60 m)	18 ft 6 in (5.63 m)	14 ft 7 in (4.49 m)	18 ft 1 in (5.51 m)
2 ft (610 mm) flat bottom	14 ft 3 in (4.34 m)	14 ft 11 in (4.55 m)	18 ft 4 in (5.58 m)	14 ft 6 in (4.42 m)	18 ft 0 in (5.48 m)
8 ft (2.44 m) flat bottom	13 ft 1 in (3.99 m)	13 ft 9 in (4.19 m)	17 ft 5 in (5.30 m)	13 ft 4 in (4.07 m)	17 ft 1 in (5.21 m)
Overall reach from swing pivot	18 ft 4 in (5.58 m)	17 ft 6 in (5.32 m)	20 ft 9 in (6.31 m)	18 ft 7 in (5.66 m)	22 ft 0 in (6.67 m)
Loading height	11 ft 9 in (3.57 m)	12 ft 1 in (3.68 m)	14 ft 2 in (4.32 m)	12 ft 8 in (3.86 m)	15 ft 7 in (4.75 m)
Loading reach	6 ft 9 in (2.05 m)	7 ft 0 in (2.13 m)	9 ft 9 in (2.98 m)	2 ft 10 in (0.88 m)	4 ft 8 in (1.43 m)
Swing arc	180°	180°	180°	180°	180°
Bucket rotation – speed hole	204°	204°	204°	198°	198°
Digging force:					
Bucket cylinder – SAE rated 3,050 psi	12,933 lb (5 755 daN)	12,933 lb (5 755 daN)	12,933 lb (5 755 daN)	11,968 lb (5 326 daN)	11,968 lb (5 326 daN)
Dipper cylinder – SAE rated 3,050 psi	8,588 lb (3 822 daN)	8,100 lb (3 605 daN)	5,782 lb (2 573 daN)	7,218 lb (3 362 daN)	5,337 lb (2 420 daN)

NOTE: Lift capacities apply straight to the rear of prime mover. 4WD with 14 x 17.5 front tires, 16.9 x 28 rear tires, and equipped with 24 in (610 mm) heavy-duty bucket except as noted.

STANDARD EQUIPMENT

OPERATOR ENVIRONMENT

See page 1

ENGINE

FPT F5 diesel
Selective Catalytic Reduction – SCR
Full flow engine oil filter
Aspirated air cleaner – replaceable dual element dry type with radial seal
Fuel filter with water trap
Radiator with de-aeration bottle
Antifreeze to -34° F (-37° C)
Electronic throttles – foot and rotary hand
Self-adjusting belt
High Pressure Common Rail computer controlled injection with diagnostic features
ECO Power Mode
Auto Engine Idle
Auto Engine Shutdown
Auto Protection Shutdown
Electronic Fuel Priming
Glow Plugs

TELEMATICS

CASE SiteWatch™ Telematics includes:
Hardware and 5-yr advanced data subscription

OPTIONAL EQUIPMENT

OPERATOR ENVIRONMENT

Speed selectable Auto Ride Control
ROPS/FOPS certified protective canopy

DRIVETRAIN

H-Type Powershift transmission, 4F-3R, hydraulic clutch shifting, kick down, transmission disconnect and FNR switch in loader control lever, includes auto shift mode

LOADER

Auxiliary hydraulics for loader-mounted equipment with thumb-operated proportional control
Hydraulic front quick coupler
Tool portfolio of additional attachments
Buckets – see page 2

DRIVETRAIN

Power Shuttle 4F-4R synchromesh transmission
Front axle:
4WD mechanically driven front axle
Rear axle:
4WD heavy-duty outboard planetary drive
Torque converter – 11.8 in (300 mm)
On-the-go electric 4WD control
Electric F/R shuttle control
Electric differential lock control, push-button
Park brake, spring-applied, hydraulic release – SAHR

HYDRAULICS

Load Sensing Closed Center with Variable Volume Pump
Heavy-duty hydraulic oil cooler
7-micron, spin on oil filter

LOADER

Tool carrier loader arms with parallel lift in both directions and return to dig; Single lever 4-function loader control: lift, dump, clutch cut-out, differential lock

BACKHOE

Center Pivot Backhoe
In-line cylinder curved boom backhoe design
ProControl System
Cleated dirt stabilizer pads
Mechanical Transport Lock

OTHER

Forward tilt engine hood
Front/Rear tie downs
Reflective logos
Signal Lights – cab and canopy:
2 rear tail/stop
2 front flashers/turn
2 rear flashers/turn
Working/Driving Lights – cab and canopy:
Adjustable halogen work lights – 55 W:
4 front
4 rear
Master disconnect switch and remote jump-start terminals
Hydrostatic steering
Backup alarm
Vertical spin-on engine oil, fuel and hydraulic filters
Tool Box

WARRANTY

1-Year/Unlimited-Hour Full-Coverage Base Limited Warranty
2-Year/2,000-Hour Extended Engine and Drivetrain Warranty

BACKHOE

Overlapping Cylinder Boom with Extendahoe®
1-way auxiliary hydraulics
2-way auxiliary hydraulics
Combined 1-way/2-way auxiliary hydraulics
Backhoe Booms:
14 ft Standard Boom
14 ft Extendahoe®
15 ft Extendahoe®
Pilot operated control system:
Thumb-operated proportional Electro-Hydraulic Extendahoe® control
Thumb-operated horn button
Thumb-operated auxiliary hydraulic control
Infinitely adjustable towers
In-cab switchable “excavator to backhoe” control pattern change
Flip over stabilizer pads
Bucket quick coupler
Hydraulic transport lock
Buckets – see page 2

OTHER

LED Working/Driving Light Package:
4 front
4 rear
Dual 12 volt batteries
Cold Weather Lubricants

SERVICE PARTS

3 inch seat belt
N Series compatible backhoe coupler for in-line cylinder backhoe

CaseCE.com

©2024 CNH Industrial America LLC. All rights reserved. CASE is a trademark registered in the United States and many other countries, owned by or licensed to CNH Industrial N.V., its subsidiaries or affiliates. CNH Industrial Capital is a trademark in the United States and many other countries, owned by or licensed to CNH Industrial N.V., its subsidiaries or affiliates. Printed in U.S.A. Contains 10% post-consumer fiber.

IMPORTANT: CASE Construction Equipment Inc. reserves the right to change these specifications without notice and without incurring any obligation relating to such change. Availability of some models and equipment builds vary according to the country in which the equipment is used. The illustrations and text may include optional equipment and accessories and may not include all standard equipment. Your CASE dealer/distributor will be able to give you details of the products and their specifications available in your area.



CASE Construction Equipment is biodiesel-friendly. NOTE: All engines meet current EPA emissions regulations. All specifications are stated in accordance with SAE Standards or Recommended Practices, where applicable.



Always read the Operator's Manual before operating any equipment. Inspect equipment before using it, and be sure it is operating properly. Follow the product safety signs and use any safety features provided.