

MAXXUM

MAXXUM

TRACTORS FROM
115 - 150 HP



CASE IH

CASE IH

THE MAXXUM SERIES

ADVANTAGE REDEFINED



From the latest FPT engines – more frugal, cleaner and with greater power outputs than before – to new operating feature updates designed to make your life easier: everywhere you look you’ll find improvements.

MAXXUM CVXDRIVE

4 MODELS FROM 125 TO 150 HP WITH CVXDRIVE CONTINUOUSLY VARIABLE TRANSMISSION

- CVXDrive continuously-variable transmission with high mechanical efficiency (2x1)
- APM engine/transmission management for optimal fuel efficiency
- EcoDrive split throttle: whether transporting, baling or mowing – you’re always working at the ideal and most fuel-efficient rpm
- Hydraulic pumps with up to 150 l/min flowrate
- AccuTurn Pro – automatic turning at the headland with GPS-based triggers of headland sequences

MAXXUM MULTICONTROLLER

4 MODELS FROM 125 TO 150 HP WITH ACTIVE DRIVE 8 TRANSMISSION

- ActiveDrive 8 – semi powershift transmission
- Proven Multicontroller armrest for excellent ease of operation
- Up to 4 (mech.) or 4 (electr.) rear remote valves
- Headland Management Control II (HMC II) and ISOBUS III
- 540/540E/1,000 rear PTO speeds
- Hydraulic pumps with up to 150 l/min flowrate

MAXXUM

5 MODELS FROM 116 TO 150 HP WITH ACTIVE DRIVE 4 TRANSMISSION

- ActiveDrive 4 – semi powershift transmission
- Option of high or low roof
- Up to 4 mechanical rear remote valves and up to 3 electrical mid-mounted remote valves
- 540/540E/1,000 rear PTO speeds with optional ground drive
- Hydraulic pumps with up to 121 l/min flowrate

GOOD REASONS TO BUY.....	4 – 5
A MACHINE TO HARNESS YOUR FULL POTENTIAL	6 – 7
ONE STANDARD THREE PACKAGES	8 – 9
CAB	10 – 15
ENGINE, TRANSMISSION, DRIVELINE	16 – 25
PTO, HYDRAULICS AND L FRONT LOADER	26 – 33
AFS, AFS CONNECT AND HMC II	34 – 41
SERVICE	42 – 43
TECHNICAL DATA	44 – 47

GOOD REASONS TO BUY

The Case IH Maxxum series was made for a great variety of tasks: front axles for standard or heavy loader works, steering assistance and simply more comfort inside the cab to make you more productive.

EFFICIENCY

POWERED BY CASE IH

Increase fuel efficiency with the Maxxum series, the leader in the mid-power range.

- FPT engine: 6-cylinder with 6.7 l capacity or 4-cylinder with 4.5 l
- Max. torque up to 650 Nm at 1,500 rpm
- Speed: 50 kph at 1,700 rpm
- Maintenance: every 750 hrs
- Power reserve: 40 % torque rise



PRECISION

EXACTLY AS YOU IMAGINE

Maximise your accuracy with correction guidance, turn assistance and more.

- AccuGuide: 1.5 cm accuracy
- HMC II: record and run functions
- AFS AccuTurn Pro: turning automation
- Adaptive Steering Control (ASC): customisable wheel rotation

COMFORT

FEELS LIKE COMING HOME

Easily access to whatever you need. Adjust settings on the go.

- Cab: integrated cooling box, heated/ventilated seat, noise 69 dB(A) only
- View: low mounted front wiper, 40,000 lumens of LED light, 4 cameras
- Ride: cab and front axle suspension
- AFS Pro 700 Plus: 12.1" high resolution screen, offers a 20 % bigger screen and higher resolution for best readability



AFS CONNECT

WORK SMARTER, NOT HARDER

Manage farm, fleet and data exchanges to smarten up your work on and off fields.

- Farm: fields, applications, agronomic data
- Fleet: machine locations & parameters
- Data: agronomic data sharing
- 3 years SAFEGUARD CONNECT package* available. It includes
 - 3-year extended warranty
 - 3 years of AFS Connect™ services
 - 24/7 MAXService
 - Pre-season check
 - Operator training by the dealer

*) ask your dealer for the availability, terms and conditions of Safeguard Connect in your country

SAFETY

PROTECT WHAT MATTERS

Take care of yourself and your Maxxum with our advanced safety features.

- Advanced trailer brake: trailer automatically slows down when necessary
- Active hold control: prevents the Maxxum CVXDrive from rolling backwards
- Parking brake: automated brake when machine is parked
- Automatic 4WD and differential lock systems



A MACHINE TO HARNESS YOUR FULL POTENTIAL.

Sustainable power designed for your needs.

The Maxxum is a universal powerhouse. Whether on the farm, road or in the field, with its powerful 4 or 6-cylinder engine from 116 to 150 hp, the Maxxum manages every task with ease. With the Maxxum 150, Case IH offers something no other manufacturer can provide: the lightest, smallest tractor in the industry with a six-cylinder engine of this power output.

MAXXUM CVXDRIVE – 4 MODELS FROM 125 TO 150 HP

As an innovator in continuously variable transmission technology, Case IH remains at the forefront of CVT design and implementation, creating systems that offer the ultimate in efficiency yet are intuitive to operate. The Case IH CVXDrive transmission suits all operators, from full-time staff to occasional drivers.

MAXXUM MULTICONTROLLER – 4 MODELS FROM 125 TO 150 HP

Intuitive operation is the hallmark of every Case IH Multicontroller-equipped tractor, with all the benefits of higher productivity and greater efficiency. Now, with the 24F/24R ActiveDrive 8 eight-speed powershift transmission featuring automatic shifting, Maxxum Multicontroller models are even easier to operate.

MAXXUM – 5 MODELS FROM 116 TO 150 HP

Standard Maxxum models incorporate everything necessary for modern-day farming. Maxxum owners benefit from the ActiveDrive 4 transmission with 16F/16R 40 kph four-speed powershift, a comfortable cab, up to four mechanical remote valves and the same implement-handling capabilities as every Maxxum model.

MODELS	Rated power ECE R120 ¹⁾ @ 2,200 rpm (kW/hp(CV))	Maximum power ECE R120 ¹⁾ with Power Management ²⁾ @ 1,800 - 1,900 rpm (kW/hp(CV))	Number of cylinders / Capacity (cm ³)	Max. pump flow rate Standard (Optional) (l/min)	Max. lift capacity (kg)
Maxxum 150 CVXDrive / Maxxum 150 Multicontroller / Maxxum 150	110 / 150	129 / 175	6 / 6,728	150 (-) / 86 (150) / 86 (121)	7,864
Maxxum 145 CVXDrive / Maxxum 145 Multicontroller / Maxxum 145	107 / 145	129 / 175	4 / 4,485	150 (-) / 86 (150) / 86 (121)	7,864
Maxxum 135 CVXDrive / Maxxum 135 Multicontroller / Maxxum 135	99 / 135	124 / 169	4 / 4,485	150 (-) / 86 (150) / 86 (121)	7,864
Maxxum 125 CVXDrive / Maxxum 125 Multicontroller / Maxxum 125	92 / 125	114 / 155	4 / 4,485	150 (-) / 86 (150) / 86 (121)	7,864
Maxxum 115	85 / 116	107 / 150	4 / 4,485	86 (121)	7,864

¹⁾ ECE R120 correspond to ISO 14396 and 97 / 68 / EC ²⁾ Power Management is only available during mobile PTO and haulage applications



1

DESIGN

- Attractive bonnet design with large air vents for improved air intake
- Powerful LED lights integrated into the cooler grill – perfectly lighting your working area

2

DRIVING COMFORT AND SAFETY

- Suspended and braked front axle available as an option
- Cab suspension available for all Maxxum models
- Premium driver's seat with active suspension (Maxxum CVXDrive and Maxxum Multicontroller)
- Patented trailer brake system – Advanced Trailer Brake for Maxxum CVXDrive
- Active Steering Control to improve manoeuvrability

3

ENGINE

- 4- or 6-cylinder 4.5 l / 6.7 l FPT turbodiesel with intercooler and wastegate turbocharger
- An eye on the environment: all Maxxum models meet strict Euro Stage V emissions standards
- State-of-the-art combustion process – no EGR needed
- Engine power management provides up to 24 hp extra boost
- 750 hour service interval

4

FRONT MOUNT SPACE

- Integrated front hitch with optional front hitch management and automatic PTO
- Optional Adaptive Steering Control (ASC) and programmable steering wheel revolutions
- Electrical joystick – quickly switch between rear and front remote valves

5

HYDRAULICS

- CCLS hydraulic pumps with flow rates of 86 l/min up to 150 l/min at 210 bar pressure
- Up to 7,864 kg rear lifting capacity and 3,100 kg front hydraulic lifting capacity
- Up to 4 mechanical or 4 electrical rear remote valves (Maxxum CVXDrive and Maxxum Multicontroller)
- Up to 4 mechanical rear remote valves (Maxxum)
- Up to 3 electrical mid mounted remote valves and Power Beyond connections (load sensing) optional

6

A CHOICE OF TRANSMISSIONS

- CVXDrive continuously-variable transmission from 0 – 50 kph with active hold control
- ActiveDrive 4 or ActiveDrive 8 semi powershift transmission with automatic gear changes and programmable powershuttle
- Electronic parking brake
- All transmission versions reach 40 kph at low engine speed (40 kph ECO)

ONE STANDARD – THREE PACKAGES

The choice is yours



Your machine, your choice of comfort. Choose from our packages to tailor your Maxxum to your specific needs: Cover your essential needs with Selection, expand your capabilities with Advanced or make use of the full potential our Maxxum series offers with Professional.

The equipment packages can be changed by Case IH without prior notification. Please contact your local dealer for the latest configuration.

PROFESSIONAL

UNLOCK THE FULL POTENTIAL OF THE TRACTOR.

MAXXUM CVXDRIVE

- CVXDrive transmission with custom driveline settings
- Electro-hydraulic remotes and 150 l/min hydraulic pump
- 3-speed PTO (540 / 540E / 1,000 or 540E / 1,000 / 1,000E)
- High roof cab with air conditioning, passenger seat & cab suspension
- Front axle suspension
- Front linkage with front hitch management & hydraulic top link
- Advanced headland management (HMC I) & AFS AutoGuide option on AFS Pro 700™ Plus touchscreen monitor is standard
- Isobus Class II or III

MAXXUM MULTICONTROLLER

- Highly productive ActiveDrive 8 transmission with 24x24 gears, 8-speed Powershift and double clutch technology
- Electro-hydraulic remotes and 150 l/min hydraulic pump
- Engine speed management & 3-speed PTO (540 / 540E / 1,000 or 540E / 1,000 / 1,000E)
- High roof cab with air conditioning, passenger seat & cab suspension
- APM (Automatic Productivity Management)
- Front axle suspension
- Front linkage with front hitch management & hydraulic top link
- Advanced headland management (HMC II) & Autoguidance ready on AFS Pro 700™ Plus touchscreen monitor
- Isobus Class II or III

ADVANCED

ADVANCED FEATURES FOR DAILY OPERATIONS.

MAXXUM CVXDRIVE

- CVXDrive transmission with custom driveline settings
- Electro-hydraulic remotes and 150 l/min hydraulic pump
- 3-speed PTO (540 / 540E / 1,000 or 540E / 1,000 / 1,000E)
- High or low roof cab with air conditioning, passenger seat & cab suspension
- Front axle suspension
- Optional advanced headland management (HMC II) & Auto-guidance options on AFS Pro 700™ Plus touchscreen monitor
- Isobus Class II optional

MAXXUM MULTICONTROLLER

- Highly productive ActiveDrive 8 transmission with 24x24 gears, 8-speed Powershift and double clutch technology
- Electro-hydraulic remotes and 150 l/min hydraulic pump
- Engine speed management & 3-speed PTO (540 / 540E / 1,000 or 540E / 1,000 / 1,000E)
- High or low roof cab with air conditioning, passenger seat & cab suspension
- Front axle suspension
- Optional advanced headland management (HMC II) & Auto-guidance options on AFS Pro 700™ Plus touchscreen monitor
- Isobus Class II optional

MAXXUM

- Proven & efficient Active-Drive 4 transmission with 16x16 gears and 4-speed Powershift
- Mechanical remotes and 121 l/min hydraulic pump
- Engine Speed Management & 3-speed PTO (540 / 540E / 1,000 or 540E / 1,000 / 1,000E)
- High or low roof cab with air conditioning, passenger seat & cab suspension
- Front axle suspension
- Optional headland management (HMC)

SELECTION

ESSENTIAL SELECTION OF OPTIONS TO COVER CUSTOMER NEEDS.

MAXXUM MULTICONTROLLER

- Highly productive ActiveDrive 8 transmission with 24x24 gears, 8-speed Powershift and double clutch technology
- Mechanical remotes and 86 l/min hydraulic pump (150 l/min optional)
- 3-speed PTO (540 / 540E / 1,000 or 540E / 1,000 / 1,000E)
- High or low roof cab with air conditioning, passenger seat & cab suspension
- Optional front axle suspension

MAXXUM

- Proven & efficient Active-Drive 4 transmission with 16x16 gears and 4-speed Powershift
- Mechanical remotes and 86l/min hydraulic pump (121 l/min optional)
- 3-speed PTO (540 / 540E / 1,000 or 540E / 1,000 / 1,000E)
- High or low roof cab with air conditioning, passenger seat & optional cab suspension
- Optional front axle suspension



MORE THAN A GOOD FEELING

Discover next level comfort.

Early starts and late finishes are part and parcel of farming. That's why Case IH designed a workplace to ensure the operator remains comfortable hour after hour, day after day.

ALL AROUND – WELL THOUGHT-OUT

Case IH ergonomic engineers have put every operating feature at your fingertips, whatever the level of tractor specification. Maxxum tractors are simple to control, nimble to manoeuvre and can be equipped with joystick controls which are a perfect cab fit.

COOL STORAGE

This newly-designed cooling box provides enough space for food and drinks even for the longest working days. With ergonomics in mind, the box is placed in easy reach of the driver without impeding the view out the front.

LET THERE BE LIGHT

Case IH gives you even more illumination with the latest generation of Maxxum tractors. Front working lights and roof styling incorporate a full 360-degree lighting package to ensure you can see not just what's ahead of you and how things are performing to the rear, but out to the extremities of your implement as well.



ASCEND YOUR HEATED AND VENTILATED SEAT!

The Maximo Evolution leather seat with active suspension and integrated heating and ventilation offers the ultimate level of comfort for Maxxum Multicontroller and Maxxum CVXDrive.



NEW

LOW MOUNTED WIPER INCREASES THE SWEEPED COVERAGE AREA BY 60% COMPARED TO PREVIOUS MODEL.

THE MAXXUM CONTROL CENTER

Everytime. Everything. Under control.

DESIGNED LIKE A TOOL BELT

If you've operated a Maxxum Multicontroller or Maxxum CVXDrive before, you'll know how intuitive its controls are; if you haven't, take a seat and find out! These are tractors designed by people who understand tractors – people who understand farming. Whether your requirement is for a standard spec machine or one with the most advanced technology package, there is a level of Maxxum to suit, each as simple to operate as the others.

GET SOME PERSPECTIVE

The tractor performance monitor is thoughtfully located on the right-hand A-pillar and, combined with the AFS Pro 700™ Plus touchscreen monitor, the Maxxum Multicontroller and Maxxum CVXDrive instrument layout provides you with a clean, comprehensive overview.

- 1 AFS PRO 700™ PLUS TOUCHSCREEN
- 2 ADVANCED JOYSTICK WITH SHUTTLE FUNCTION
- 3 MULTICONTROLLER
- 4 UP TO 4 ELEC. REMOTES POSSIBLE
- 5 ICP – INTUITIVE CONTROL PANEL
- 6 FRONT/REAR PTO ON/OFF
- 7 HYDRAULIC AND HITCH SETTINGS
- 8 TRACTOR- AND PERFORMANCE-MONITOR LOCATED IN THE RIGHT-HAND A-POST

AFS PRO 700 PLUS: ONE MONITOR, INFINITE POSSIBILITIES

Look to the future!



CUSTOMISABLE FOR YOUR NEEDS

The AFS Pro 700™ Plus monitor provides an overview of all tractor functions. Choose up to 12 important Maxxum parameters and store them in this quick access menu to be recalled when you need them.

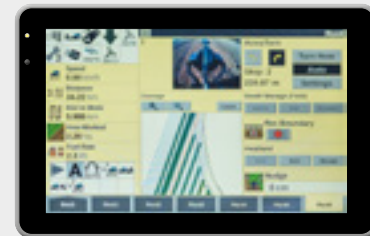

KEEPING AN EYE ON WHAT'S IMPORTANT

The AFS Pro 700™ Plus can show up to three live videos from cameras at the rear of the tractor, or the rear of large implements. This makes backing up with implements such as large trailers or balers easier than ever.

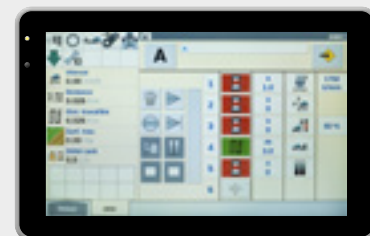

AUTOMATED HEADLAND MANAGEMENT

The Case IH Headland Management Control II system (HMC II) can increase automation at the headland and reduce repetitive tasks, ensuring a consistent workflow. Two processes can be recorded in real time while you work, or by inputting commands on the The AFS Pro 700™ Plus. Triggers can include time or distance travelled, depending on the settings.



INTERFACE WITH YOUR TRACTOR AND AFS CONNECT

The new AFS Pro 700™ Plus monitor is the main mode of operating and supervising your Maxxum. The latest connectivity package allows real time information and universal data transfer. Leverage your data faster with enhanced multi task capabilities to run advanced Case IH Smart Farming applications such as Case IH Accuguide, Section and Rate Control, or exchange data from your monitor to your MyCase IH AFS Connect telematics portal.

AFS Pro 700™ Plus further enhances your productivity with AEF ISOBUS certification and 4 video inputs, so you can keep an eye on everything.

The larger size and higher resolution of the screen itself gives a high-tech, high spec impression, while the construction takes into account the need for robust, hard-wearing farm technology. The full glass surface has an anti-fingerprint coating to prevent smudges. As you'd expect from Case IH, the AFS Pro 700™ Plus is a modern, innovative monitor, built to last for your requirements.

INTEGRATED AEF CERTIFIED ISOBUS IMPLEMENT CONTROL

ISOBUS is a modern tractor/implement interface allowing implement operation on the AFS Pro 700™ Plus. This can reduce the need for a second display in the cab. Connect via the 9-pin ISOBUS plug at the rear or front of the Maxxum. Maxxum Multicontroller and Maxxum CVXDrive are also compatible with ISOBUS III, which allows the implement to control tractor functions such as the remote valves, PTO, rear hitch and ground speed.



CLEAR PERFORMANCE MONITORING

You can view all the critical Maxxum performance values such as oil pressure and coolant temperature on the The AFS Pro 700™ Plus. Regular monitoring and easy-to-understand data ensure your Maxxum is ready for work when you need it. For further analysis, you can choose to transfer your data from the The AFS Pro 700™ Plus directly to your MyCase IH platform to analyze and improve uptime in the field, without having to record it in a notebook.



AUTOMATED STEERING AND TURNING

AFS AccuGuide and AFS AccuTurn Pro work together to provide fully automatic steering and headland turning. Combined, they can improve machine uptime in the field and reduce input costs by reducing overlaps. With AFS AccuTurn Pro, you can automate headland processes and integrate HMC II tractor and implement functions into the turning process.

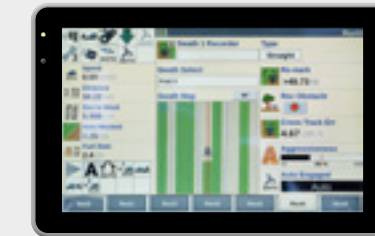

AN ENGINE BUILT WITH PASSION

When know-how generates real added value

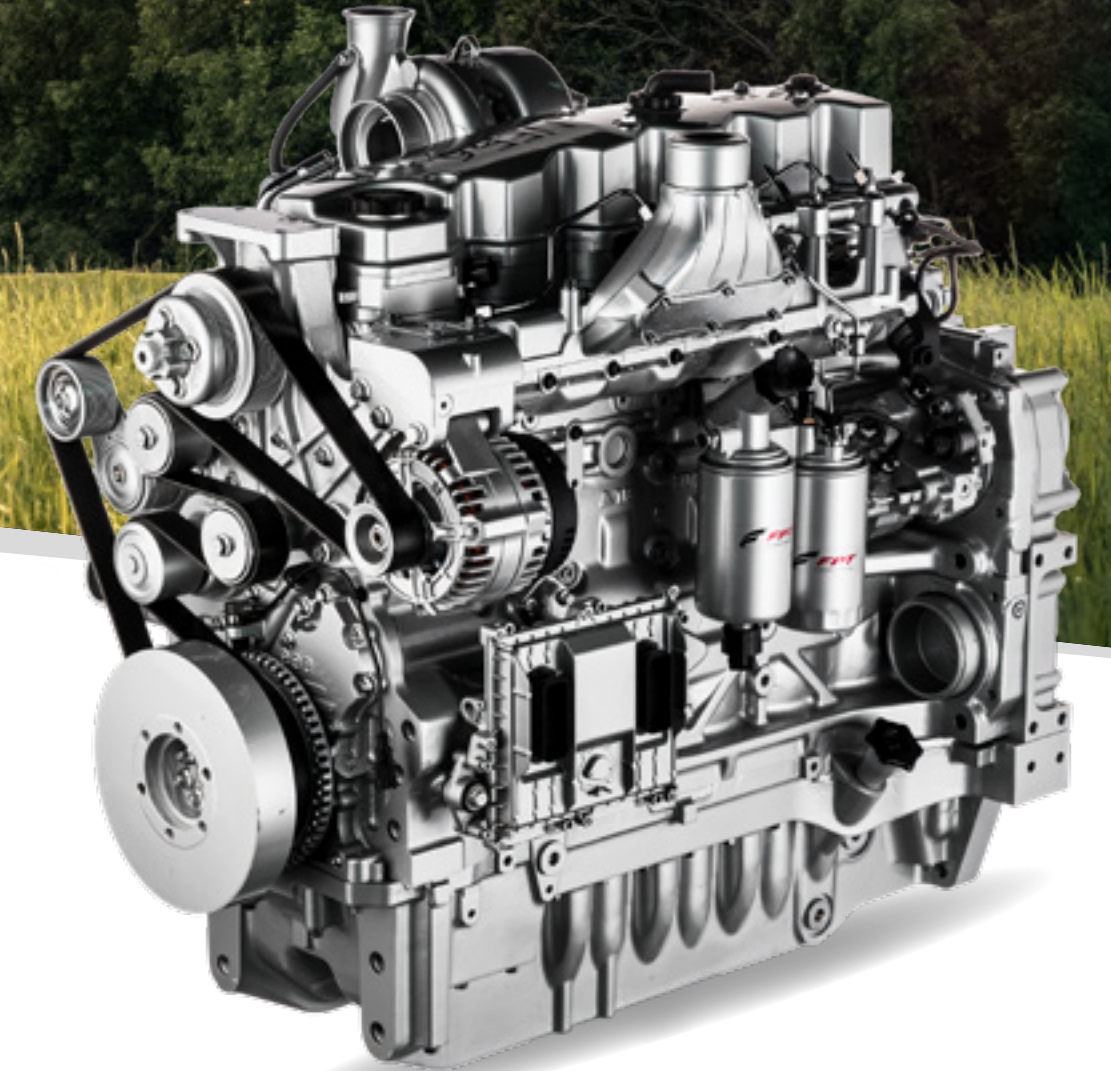

Capable of cutting any task down to size, the heart of every Maxxum tractor is the industry's most modern, frugal, and productive engine produced by our sister company, FPT Industrial, a renowned global leader in engines.

POWER WHEN YOU NEED IT MOST

All our Maxxum models are equipped with FPT engines. Starting from the Maxxum 115 with 4 cylinders (116 hp) to the flagship model Maxxum 150 with 6 cylinders (150 hp). An Engine Power Management boost for PTO, hydraulic and transport work takes those figures from 145 to 175 hp.

PROTECTING OUR PLANET

All engines are fully Stage V compliant, courtesy of HI-eSCR2 exhaust after-treatment, without impact on the engine's performance. The system is fully automatic, requiring no operator action, so you can breathe easy as you work hard.

TIME-EFFICIENT. COST-EFFICIENT.

Daily maintenance is easily managed thanks to the bonnet which lifts open in one piece. And with 750-hour service intervals, Maxxum tractors require the minimum of regular scheduled care. Maxxums spend less time in the yard and more where it matters – in the field, returning the investment you've made in them.

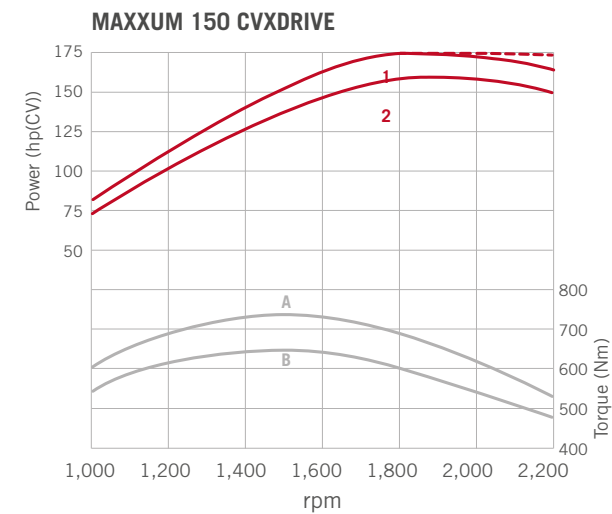

Curves 1 and A with Power Management / Curves 2 and B without Power Management

ADVANTAGES

- Up to 24 additional hp(cv)
- Four- or six-cylinder options at 145 hp
- Approved to use HVO (Hydro-Treated Vegetable Oil, a synthetic fuel)
- Automatic Productivity Management (APM) and ECO drive help to cut fuel consumption on Maxxum CVXDrive models
- Up to 250 litres of fuel tank capacity
- Industry leading 750-hour service interval



YOUR CHOICE FOR MAXIMUM SUCCESS

Four-speed or eight-speed semi-powershift transmissions

Case IH recognizes that no two farm businesses have the same demands of their tractors. **Maxxum**, one of the most versatile tractor ranges in the Case IH line, is available with two semi-powershift transmission options to meet your specific requirements.

ACTIVEDRIVE 4 – CLASSIC EFFICIENCY

The proven 16F/16R four-speed Powershift transmission is the economical entry to the Maxxum series. A 17F/6R semi-Powershift with a top speed of 40 kph at a reduced engine rpm or a top speed of 50 kph are also available. The 40 kph Eco version reaches its top speed at a fuel-saving 1,850 rpm.

ACTIVEDRIVE 8 – THE NEW BENCHMARK

ActiveDrive 8 is a three-range, eight-speed powershift transmission from Case IH, providing a total of 24 speeds to cover all your bases. Range one (from 0 - 10.7 kph) is

specifically designed for heavier draft work at low speed. Range two, the main working range, covers nearly 90 % of all field, grassland and loader applications, allowing you to work under full load without any torque disruption, between 4.3 - 18.1 kph. For road travel, the transmission is designed to start in range three, and a skip-shift function allows you to quickly progress through the powershift speeds.

	Standard features	Optional automatic features
Smart Range Shift	●	●
Memory Shuttle	●	●
Smooth Shift	●	●
Pedal Kick Down		●
Auto-Functions		●
ActiveClutch II		●

ACTIVEDRIVE 8 ADVANTAGES

- Eight-speed powershift in three ranges, 24x24 gears
- 40 kph, 40 kph ECO at reduced engine speed or 50 kph
- Selectable transmission automation
- Creeper speeds available down to 190 m/h

1 ActiveDrive 4 transmission controls in Maxxum models

2 Advanced armrest control in Maxxum Multicontroller™ tractors equipped with ActiveDrive 8 transmission.

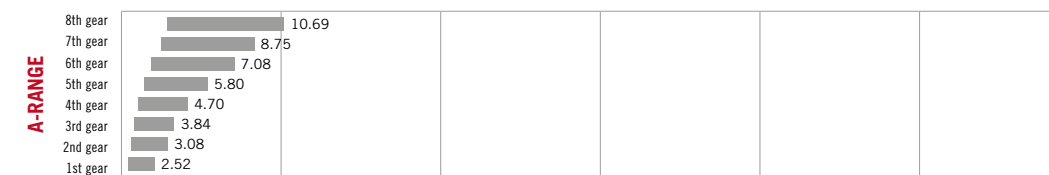
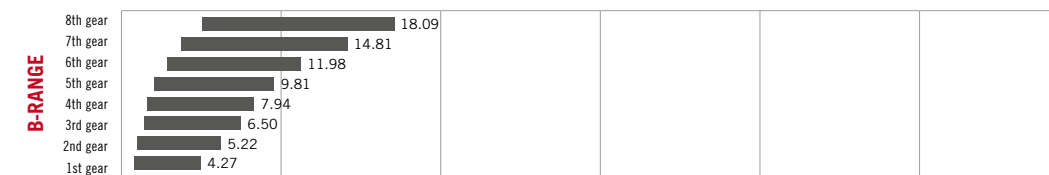
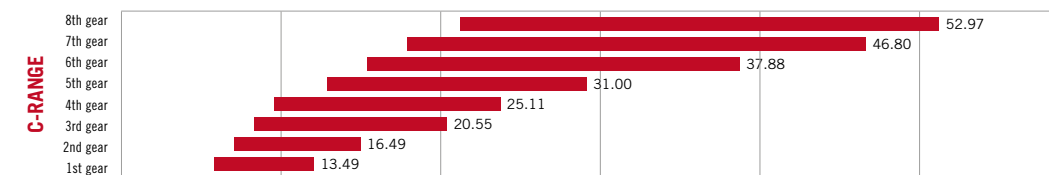

ActiveDrive 8 - 24F x 24R gears, 8-speed Powershift transmission [kph]



CVXDRIVE TRANSMISSION – SEAMLESS ACCELERATION BETWEEN 0-50 KPH

SUMMING PLANETARY TRANSMISSION – COMBINES DRIVE SPEEDS OF THE ENGINE AND HYDROSTAT UNIT FOR ACTIVE HOLD CONTROL

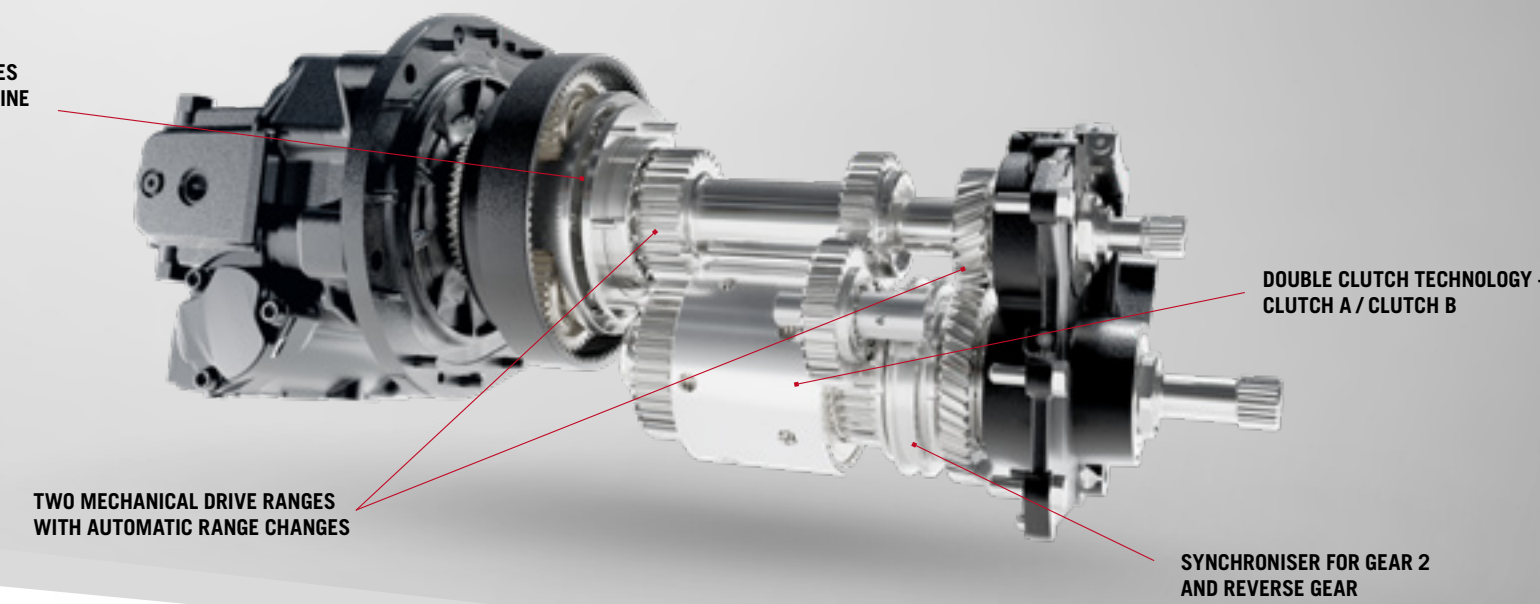

TWO MECHANICAL DRIVE RANGES WITH AUTOMATIC RANGE CHANGES

DOUBLE CLUTCH TECHNOLOGY - CLUTCH A / CLUTCH B

SYNCHRONISER FOR GEAR 2 AND REVERSE GEAR

CONTINUOUSLY VARIABLE – PERMANENTLY EFFICIENT

Perfect interaction between engine and transmission saves fuel

The CVXDrive continuously-variable transmission is built to simply deliver the exact speed for your operation without compromise.

THE POWER OF EXPERIENCE

Seamless range changes, from standstill to 40 or 50 kph, and infinite control in key working speeds with double clutch technology – the CVXDrive transmission offers all this plus active hold control.

THE POWER OF CONTROL

Automatic, manual or Eco Draft, there is a driving mode to suit your operation. In automatic mode the CVXDrive can easily be driven by the foot throttle or Multicontroller, Manual mode allows the CVXDrive to operate in a conventional manner, while Eco Draft puts you in control of draft performance – ensuring power is delivered efficiently at key working speeds.

ECODRIVE SPLIT THROTTLE

The ECODRIVE manual throttle allows the driver to preselect minimum and maximum engine speeds, adjusting engine speed range to the work at hand. This helps you to save fuel.

A NEW DRIVING EXPERIENCE WITH CUSTOMISABLE TRANSMISSION SETTINGS

Case IH software engineers have enhanced the performance and driveability of the CVXDrive with new CVT control features that deliver smoother and more responsive characteristics, increasing uptime in the field. Drivers can change the settings easily and quickly via the AFS Pro 700™ Plus display.

- Acceleration / deceleration
- Shuttling speed
- Drive pedal behaviour



**SIMPLE TO OPERATE
SET THE SPEED –
APM TAKES CARE OF THE REST**

FUEL EFFICIENCY THANKS TO APM, NO MATTER THE JOB

The APM automatically controls the tractor's speed depending on the optimal engine speed and gear ratio to maximise performance and reduce running costs. The driver need only move the Multicontroller or step on the foot throttle, APM takes care of the rest. For even greater fuel economy, top speed is achieved at just 1,550 rpm – perfect for transport work.

NO TERRAIN TOO TOUGH

Blazing new paths

With excellent power to weight ratios, Maxxum tractors offer the ultimate combination of muscle and agility.



1 **MECHANICAL CAB SUSPENSION: ENJOY LESS BACK STRAIN AND MORE COMFORT**

MAXIMUM TRACTION EVERY SECOND

Depending on the model, Maxxum is equipped with a self-locking differential or an electrohydraulic differential with optional 4WD and differential lock management. Maxxum Multicontroller and Maxxum CVXDrive models benefit from automatic 4WD and differential lock dis/engagement.

COMFORT OF THE HIGHEST STANDARD

The suspended front axle provides a more comfortable ride, increases traction and boosts fuel efficiency. The addition of a second accumulator on Maxxum provides greater comfort both in the field and on the road, with an additional bonus of improved traction. The standard Ride Control system reduces pitching movements and improves mounted implement transport stability.

EXCELLENT MANOEUVRABILITY FOR HIGHEST FLEXIBILITY

Thanks to their compact design, Maxxum tractors have a turning circle of just 4.6 m. The dynamic fenders turn with the wheels up to 30°, keeping you agile when you need it.



ADVANTAGES

- Stable construction – high payload thanks to increased maximum permissible total weight of up to 10,500 kg
- Optional engine block side frame increases the stability of the driveline
- Braked and suspended class 3.5 front axle with 105 mm travel
- Maximum permissible front axle load of 4,900 kg
- Four high-performance brake discs on the rear axle ensure for security
- Rear tire size up to 710/60 R38 and front tires up to 600/60 R38



FRONT AXLE SUSPENSION WORKS IN BOTH DIRECTIONS: MORE COMFORT, BETTER TRACTION AND SAFETY.



OUR TOP PRIORITY: YOUR SAFETY

Innovation made to protect your health

USEFUL TOOLS FOR EVERYDAY

Heavy duty, maintenance-free, oil-immersed disc brakes are standard, whilst 50 kph models are fitted with front axle brakes for additional braking power. Trailer braking systems (air or hydraulic) are optional. All Maxxum CVXDrive models also feature an automatic parking brake. It activates automatically after 90 seconds or if the driver leaves his or her seat for more than 5 seconds.

PATENTED BRAKING SAFETY

The Advanced Trailer Brake equipped on Case IH Maxxum CVXDrive tractors enhances safety in tricky situations. The patented system actively recognizes the current driving situation as well as changes to the load on the flywheel and stabilizes the tractor by means of pulsed activation of the pneumatic trailer brakes. The system keeps tractor and trailer combination in line when decelerating either by pulling back on the Multicontroller or using the brake pedal.

EXHAUST BRAKE FOR EVEN MORE BRAKING POWER

An engine back-pressure brake is available as an option on all Maxxum models. It can reduce use of the service brake by up to 30 %, saving wear on tractor and implement brakes.

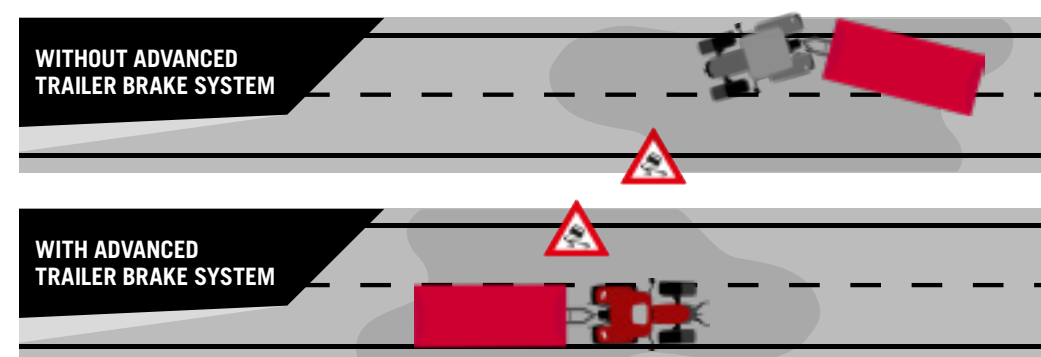

THE ADVANCED TRAILER BRAKE SYSTEM ACTIVELY RECOGNISES THE CURRENT DRIVING SITUATION AND STABILISES THE TRACTOR AND TRAILER COMBINATION BY USING THE TRAILER'S BRAKES.



NEXT LEVEL PTO

Succeed at whatever you do

Whether mowing, tedding or baling, spreading, spraying or drilling, different PTO-powered implements place different demands on a tractor's power take-off.

That's why Maxxum tractors can be specified to offer up to three PTO speeds at the rear – 540, 540E, 1,000 rpm or 540E, 1,000, 1,000E rpm. Standard speeds provide power for tough tasks such as power harrow operation, while 'E' economy speeds allow full shaft speed to be attained at lower engine rpm, reducing fuel consumption on lighter jobs. The 540E economy PTO, for example, operates at an engine speed of just 1,546 rpm.

READY TO HANDLE EVERY SITUATION

A hydraulic brake ensures implement operation stops immediately once the PTO is switched off. On Maxxum Multicontroller and Maxxum CVXDrive tractors, a PTO management system switches the PTO on mounted implements on and off at the headlands according to its rear hitch position, completely automating the dis/engagement process. There is also a ground speed PTO for special trailed equipment.

THE SPEED YOU NEED – SIMPLY SET

The constant speed memory simplifies PTO work. The AFS Pro 700™ Plus monitor lets you pre-set a suitable engine speed for the implement, which is activated by pressing a button or by the Headland Management HMC II. This saves valuable time and fuel.

ADVANTAGES

- Three PTO speeds at the rear for all Maxxum models as standard
- ECO PTO speeds for better fuel economy (540E or 1,000E at below 1,600 engine rpm)
- 1,000 rpm front PTO with wet clutch and optional front hitch management

COMPATIBILITY IS A QUESTION OF ATTITUDE

Handling every implement with ease

Whether asked to handle heavyweight cultivation kit or to power oil-thirsty implements, the implement connections on Maxxum tractors make them more than capable of supporting machines of every description.



AT-A-GLANCE OVERVIEW OF FLOWRATE AND TIMER SETTINGS ON THE AFS PRO 700™ PLUS MONITOR.

WHETHER FRONT OR REAR – PERFORMANCE IS GUARANTEED

With a lift capacity of up to 7,115 kg (on tractors with an 86 l/min hydraulic pump) or 7,864 kg (on tractors with a 121/150 l/min pump), Maxxum models are more than capable of handling what's hitched up to them, whilst a 3,100 kg front linkage is optional. Electronic Hitch Control is standard on all Maxxums, with full electronic draft control sensing and Hitch Ride Control.

HYDRAULICS YOU REALLY NEED

Depending on the configuration, the Maxxum offers a fixed displacement pump with up to 86 l/min of oil flow, whilst a high capacity, pressure flow compensating, variable displacement piston pump is optional on Maxxum and Maxxum Multicontroller models and standard on

Maxxum CVXDrive tractors (from 121 up to 150 l/min of oil). Maxxum models also feature up to four rear and two mid-mounted mechanical remote valves, while Maxxum Multicontroller and Maxxum CVXDrive tractors offer up to four rear and three mid-mounted electronic remote valves.

EXTENSIVE CUSTOMISABILITY TO FIT YOUR EXPECTATIONS

If your Maxxum is equipped with HMC II, any remote valve can be assigned to the Multicontroller. With flowrate control, you can adjust the flowrate of hydraulic oil to perfectly match the implement – either from the AFS Pro 700™ Plus monitor or via the dial encoder under the armrest cover. Timing and prioritizing the remote valves is another standard function.

ADVANTAGES

- Rear lift capacity of up to 7,864 kg
- Optional 3,100 kg front linkage
- 86/121/150 l/min hydraulic pump
- Electronic Hitch Control with full electronic draft control sensing and Hitch Ride Control
- Up to four rear and three mid-mount remote valves available
- New rear remote design and colour coding make hitching up easier

1 ISOBUS is available as an option for implements that use this function. Working with the AFS Pro 700™ Plus you can control implements with ease from one monitor.

2 Hitching up to implements is easy thanks to a logical layout.

3 Cat II-III lower link with automatic stabilisers

4 Exterior buttons for hitch, electrical remote and PTO on/off

EXPAND YOUR CAPABILITIES

The new Case IH L loader series

Benefit from maximum precision, rapid response, and next level capacities for a remarkable ease of handling.

Maxxum tractors are available loader-ready and designed to operate as a system with three new Case IH L loader ranges – the T-, U - and A-range.

Three ranges with 12 models in total were developed so that you can find your perfect match according to your individual requirements. You just choose and we take care of the rest, just as usual.

RANGES	T	U	A
SHOCK ELIMINATOR System®	Standard		
MACH System®	Standard		
FITLOCK 2+ System®	Standard		–
FITLOCK_M System®	–		Standard
MACH 2 System®	Standard		Option
FAST-LOCK System®	Option	Option	–
AUTO-UNLOAD System®	Option	–	–

T RANGE



PREMIUM DESIGN – MAXIMUM OUTPUT

THE T RANGE

The flagship T series is a premium specification range including hydraulic self-levelling as standard to increase the lifting power by 35 %.

This unique system automatically maintains the implement angle by using two perfectly integrated compensation rams, constantly connected to the dumping rams.

- 5 models available
- Maximum lift heights from 4.21 up to 4.57 m
- Maximum lift capacities from 2,366 up to 3,076 kg

U RANGE



VERSATILE AND DURABLE

THE U RANGE

The robust U front loader range with mechanical self-levelling is ideal for everyday handling tasks. They are easy to operate and are offered with the FITLOCK 2+ System® for automatic locking and unlocking.

- 6 models available
- Maximum lift heights from 4.21 up to 4.57 m
- Maximum lift capacities from 2,561 up to 2,825 kg

A RANGE



THE BASIS OF SUCCESS

THE A RANGE

These efficient front loaders are equipped with mechanical self-levelling as standard, and the FITLOCK 2M System® for fast loader hitching/unhitching. To handle a wide range of attachments, loaders series A offer a third hydraulic function.

- 1 model available
- Maximum lift height 4.04 m
- Maximum lift capacity 2,480 kg

L FRONT LOADERS

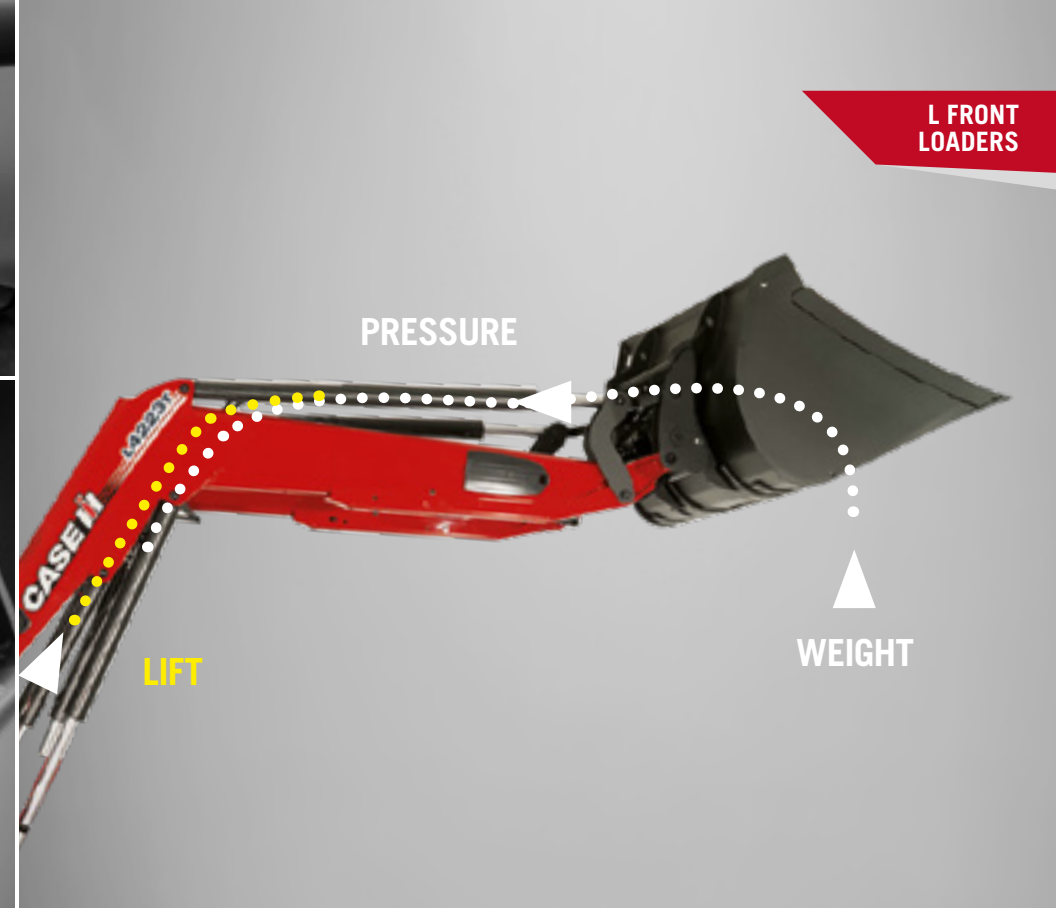

HIGH-SPECS FOR HIGHEST DEMANDS

Simply accomplish more – in less time

STRONG CONCEPTS. BIG IMPACT.

The loader bracket is optimally positioned near the tractor's center of gravity, reducing stress on the front axle and distributing the weight of the load for greater stability. Perfect lifting capacity is ensured by a vertical lifting curve which provides a constant lifting force from the bottom upwards.

- Bracket position close to center of gravity
- Exceptional forward reach for discharge and a convenient position to load a trailer or a mixer
- The design ensures a vertical lifting curve which provides a constant lifting force from the bottom upwards

ANYTIME. MORE THAN READY.

U and T range loaders are fitted with the FITLOCK 2+ premium system, allowing automatic locking of the loader. The MACH multicoupler allows quick coupling and uncoupling of all hydraulic and electric loader functions with ease, even under pressure.

LOADERS FULL OF ENDLESS POSSIBILITIES

The Case IH L loader series are designed with a modular implement carrier (MX or EURO implement carrier) which can handle more than 35 types of attachments. Depending on the model chosen, you can electro-hydraulically hitch and unhitch implements without leaving your seat – a new dimension of convenience with the FAST-LOCK system®. In addition to hydraulic locking, the MACH 2 system allows the connection of the third and fourth function with a single movement, even under pressure. Mixed up connections have become a thing of the past.

PCH (ONLY ON T SERIES)

NUMBERS SPEAK LOUDER THAN WORDS: 35% MORE POWER

The T range is equipped with the PCH hydraulic self-levelling linkage. This unique feature automatically maintains the implement angle by using two perfectly integrated compensation rams, constantly connected to the dumping rams. The PCH system also increases lifting power by up to 35%. The weight of the loaded attachment generates pressure in the tilt rams which is transferred to the PCH rams and supports the lifting process.



SMART, COST-EFFICIENT AND ECO-FRIENDLY



Case IH Advanced Farming Systems (AFS)

As one of the leading agricultural manufacturers of precision farming technology, Case IH helps you to enhance your output and to be fit for the future.



Therefore, we offer a wide range of applications that combine information input and the unique AFS Connect™ telematics portal into a goal-oriented data management system for registered machines. Of course, this also includes full ISOBUS compability and the HMC II headland management system.



Get ready for repeatable accuracy, reduced overlaps, lower operating costs and maximisation of profits – get ready for advanced farming!



 Slip **3 %**
 % kW
 Engine Power **91 %**

Machine ID	Operator	Field	Start Time	End Time	Ground Speed (km/h)	Engine Power (% kW)	Fuel Rate (l/h)	Covers Area (ha)
001	John	Field A	08:00	09:30	6.0	54	89.3	26.3
002	Mary	Field B	09:00	10:30	5.5	52	85.0	24.5
003	David	Field C	10:00	11:30	6.2	56	90.0	27.0
004	Emily	Field D	11:00	12:30	5.8	53	87.0	25.5

 Ground Speed **6.0 km/h**
 % kW
 Engine Power **54 %**

 Fuel Rate **89.3 l/h**
 Covers Area **26.3 ha**

WORK SMARTER, NOT HARDER: CASE IH AFS

Take advantage of maximum precision – day in and day out

Everything you need to maximise your profitability: Achieve repeatable accuracy down to 1.5 cm, reduce overlaps, and cut operating costs. Case IH Advanced Farming Systems (AFS™) have been at the forefront of precision farming for more than a decade.

ALWAYS ON TRACK WITH ACCUGUIDE

Customise your Maxxum with the fully-integrated AFS AccuGuide guidance system, the AFS Pro 700™ Plus touchscreen monitor and steering position sensors.

Or equip your Maxxum with one of the AFS guidance solution available at your dealership. Using our Case IH AFS RTK+ signal gives you track-to-track accuracy of 1.5 cm. Even when there are signal gaps, the system bridges connection failures or signal dropouts of up to 20 minutes thanks to the xFill feature.

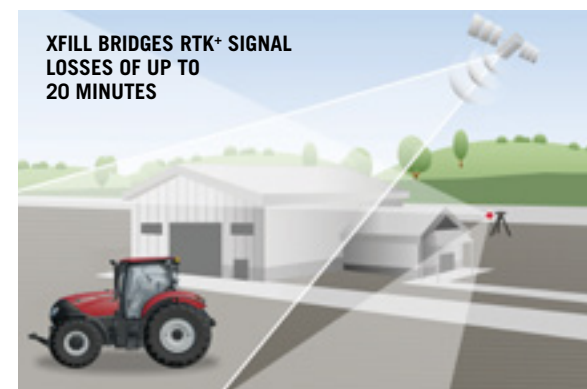

ADVANTAGES

- Range of signal accuracies available
- Receivers use Galileo, GPS and GLONASS signals
- Low cost RTX signal solution
- Optional high accuracy Case IH AFS RTK+ signal with accuracy levels close to 1.5 cm
- Integrated automatic AccuGuide guidance
- xFill bridges RTK+ signal gaps of up to 20 minutes

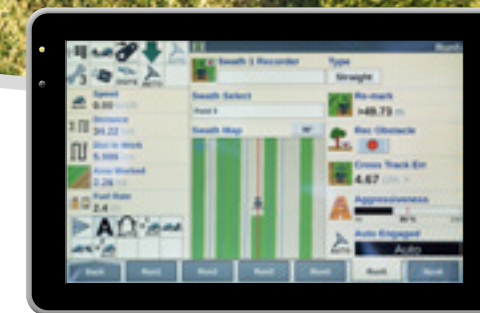

**AUTOMATED GUIDANCE
WITH AFS ACCUGUIDE**



AFS CONNECT

Manage your farm, fleet and data remotely

AFS Connect lets you remotely monitor and manage your farm, fleet and data, allowing you to optimise your performance, productivity and flexibility. Efficiently visualise your equipment with little to no idle time. With all the information at your fingertips, you can successfully manage your operations anytime, anywhere!



USER-FRIENDLY INTERFACE

- New, intuitive and redesigned interface with all information at your disposal
- Ergonomic platform divided into 3 sections: fleet, farm & data

TIME-SAVING MANAGEMENT

- Visualisation of data from multiple machines in one field
- Manage your activity & transfer data from your office to machines and vice versa

MAXIMUM PRODUCTIVITY-ENHANCING DECISION MAKING

- Notifications & visualisation of critical operating parameters
- Connect and share securely with Application Programming Interface (API) with third party partners

RECEIVE UPDATES ON YOUR DAILY OPERATIONS

- See, share and manage data on the go, in real time, from any device
- View updated machine telematic data and fault codes remotely

THE ULTIMATE SOLUTION FOR WHEN YOU'RE ON THE MOVE

- Live vehicle map lets you find machines' locations and get driving directions
- Share vehicle info, location and directions with various apps (e.g. WhatsApp) on your phone



YOUR ALL-NEW DESTINATION FOR CASE IH PRODUCT SUPPORT

MYCASEIH is a new free cloud-based platform which gives you a single place to log in for access to everything related to your Case IH farm equipment. Find an overview of all your machine and equipment, manage your users and access a support knowledge section with operator manuals, support documents, parts catalogues and more. The platform is available on all devices: smartphone (Apple & Android), tablet and desktop.

VISIT US AT
MY.CASEIH.COM



FARM MANAGEMENT

GET MORE DONE EACH DAY
OPTIMISE YOUR TIME BY EASILY ORGANISING YOUR FIELDS, APPLICATIONS AND AGRONOMIC DATA

MANAGE YOUR COMPANY

Managing your fields and your data can be time-consuming. AFS Connect optimises your time by easily organising your fields, applications and agronomic data.

With a wealth of information at your fingertips, you can boost your operation's performance.

Data visualisation: access agronomic data in near real-time for all your seeding, application and yield activities. Included: topographic, weather, equipment, or prescriptions information.

Reporting: capture all of your critical farming information on the go or directly from your equipment. Plan upcoming activities, manage logistics, share data with your trusted advisors and make informed decisions.

Usability: Keeping track of everything going on in your operation has never been easier. Whether you're on the road, in the field or at the office, the intuitive user interface keeps you informed.



FLEET MANAGEMENT

TRACK, MONITOR & MANAGE YOUR ENTIRE FLEET
EFFICIENTLY TRACK YOUR EQUIPMENT'S LOCATION & VIEW MACHINE PARAMETERS IN REAL TIME

MANAGE YOUR PRODUCTIVITY

When all your equipment operates efficiently with little to no idle time, you have the peace of mind that comes with working smarter and knowing that you're doing all you can to make the most of each growing season.

Fleet overview: access key information with detailed performance values for each machine by vehicle type. The map overview allows visualisation of connected equipment to more efficiently execute infield operations and coordinate the fleet.

Vehicle details page: access recent machine operations and get a 7 day report of the vehicle status by hours and fuel usage.

Alerts history and notifications: view and filter the faults shown to the operator on the in-cab displays. Configure and setup notifications such as vehicle speeds, oil temperature, engine load or fuel level and receive them via web or via text messages.



DATA MANAGEMENT

CONNECT AND SHARE DATA
SECURELY SHARE YOUR FARM DATA WITH TRUSTED PARTNERS, ANYTIME, ANYWHERE

MANAGE YOUR DATA EXCHANGE

Seamlessly manage, share and move data – all while ensuring you stay in complete control with your preferred trusted business partners.

Secure data sharing: Securely share selected data with trusted partners while keeping complete control over who can access each piece of generated data.

Third-party partners: wirelessly transfer two-way data between AFS Connect and trusted third-party suppliers (Trimble®, MyEasy Farm, Farmers Edge, Cropwise, CropScan Ag) to make the most of agronomic data and drive daily management decisions.

Solution for mixed fleets: Case IH customers benefit from a comprehensive solution for sharing data thanks to a recent partnership:

- DataConnect is a new cloud-to-cloud interface, in partnership with CLAAS, 365FarmNet, John Deere and New Holland. Mixed-brand fleets owners can look forward to easier data exchange and management without compatibility issues.



MACHINE OF THE YEAR
©garheute 2020 traction



CAB

PRESS CONTROLLER

Round baler loading control algorithm (software)

ISOBUS CLASS III



TRACTOR CONTROLLER

Speed adjustments made based on relevant signals from the baler



AEF Certified

ISOBUS

www.aef-isobus-database.org



HMC II / ACCUTURN PRO / ISOBUS



ISOBUS FUNCTIONS CAN BE CONFIGURED ONTO EXISTING CONTROLLERS SUCH AS THE MULTICONTROLLER, JOYSTICK AND CONTROL LEVERS.

AUTOMATED OPERATING SEQUENCES FOR INCREASED PRODUCTIVITY

Work productively, accurately, and in comfort with the headland management system, AccuTurn Pro, and integrated ISOBUS compatibility

The monitor integrated into the operator's seat armrest gives the operator full control over all the tractor's automatic functions and connecting the reversing camera.

HMC II

All Maxxum CVXDrive and Multicontroller models feature Headland Management Control II, which is designed to assist the driver when turning at the headland. Each step can be programmed either by time or distance travelled. In addition, triggers for various other automated functions can be set, such as lowering the engine speed after lifting the implement.

A headland sequence can be recorded while driving or programmed on the stand. The sequence can be played back manually or automatically via the Multicontroller, the ICP control panel in the armrest, or the AFS PRO 700™ Plus monitor.

ISOBUS III FOR BEST EFFICIENCY

In addition with ISOBUS basic standards, which suggest implement settings via the AFS Pro 700™ Plus monitor (Class I) and control implements (Class II), the Maxxum CVXDrive also offers ISOBUS Class III. With ISOBUS III, the implement automatically controls aspects of the Maxxum CVXDrive. The tractor will automatically adjust forward speed, steering (option), hitch position and PTO speed, as well as operating remote valves depending on the implement's needs. The result is perfect cooperation and improved efficiency of the implement and tractor.

AUTOMATED TURNING PROCESS

Our brand new AFS AccuTurn Pro technology combines headland management and headland steering processes. Turning radius, speed, and implement control when turning on headlands are automated and optimised, resulting in increased efficiency and improved comfort.



SERVICE SOLUTIONS

PARTS AND SERVICES

Solutions for your farming

Our professional dealer network backed up by local Case IH teams, industry-leading Case IH support tools, modern training methods, best-in-class replacement parts, support and logistics performance. All you need for an excellent all-encompassing after-sales service to keep you farming.

GENUINE PARTS

THE IDEAL CHOICE

Our wide range of top quality genuine parts can help maintain the full potential of your machine, season after season, guaranteeing top performance, utmost productivity and high residual value.

REMAN PARTS

REMANUFACTURED

Cutting-edge technology, tailored tooling, equipment and stringent quality testing allow us to remanufacture essential components of your machine to the highest standards, ensuring the same performance as new parts.

ACCESSORIES LINE

BUSINESS SOLUTIONS

Our engineers also develop solutions to cover every one of your individual demands, packaged into kits and designed to help improve business efficiency. Your Case IH dealer offers a host of partner-branded tools, small parts and accessories provided by selected partner suppliers.

MAX SERVICE

AROUND THE CLOCK. AROUND THE COUNTRY.

The Case IH support operates around the clock in high season, in close partnership with the dealer network, to minimise any downtime you might experience. Your dealer, together with Case IH Parts & Service team, has the main goal of getting you back to work as quickly as possible. Solutions may come through the priority shipment of needed parts (24/7), the support on field of Case IH technicians, courtesy units wherever applicable.

SAFEGUARD WARRANTY

PROTECT YOUR INVESTMENT

The Case IH Extended Warranty program under the same condition as the first year. SAFEGUARD WARRANTY allows you to protect your investment from exposure to risk of unexpected repair cost, farm with peace of mind, keep operating costs under control and, at same time, increase machine resale value.

SAFEGUARD CONNECT

ENHANCE YOUR PRODUCTIVITY

SAFEGUARD CONNECT™ is the combination of the best Case IH Services into one unique comprehensive package. A set of added-value services included in your new connected flagship machine*, for long-lasting protection of your investment and maximum productivity of your farming. SAFEGUARD CONNECT may include: Safe-guard Warranty, Max Service, Preseason checks, Operator training, and all the AFS Connect features and services such as the Proactive Remote Support from our control rooms, Telematics, Fleet management, Maintenance Reminders and machine history reports.



OPTIMAL FINANCING SOLUTION FOR EVERY INVESTMENT

CNH Industrial Capital is the financing company for Case IH. Our employees are financial experts and have many years of experience in agriculture. We not only know about Case IH products and the market – we also understand the individual requirements of your operations. Therefore we are always able to offer you a financial solution for your new investments that is tailored specifically to your operational requirements. Our most important goal is improving the profitability of your investments!

MODELS	MAXXUM 150 CVXDRIVE	MAXXUM 145 CVXDRIVE	MAXXUM 135 CVXDRIVE	MAXXUM 125 CVXDRIVE
ENGINE	FPT			
Number of cylinders / Capacity [cm ³]	6 / 6,728	4 / 4,485		
Type / Emission level	Common Rail Diesel engine, turbocharger and HI-eSCR2 only exhaust after treatment / Stage V			
Maximum power ECE R120 ³¹ Power Management ³² [kW/hp(CV)]	129 / 175	129 / 175	124 / 169	114 / 155
Maximum power ECE R120 ³¹ [kW/hp(CV)]	116 / 158	114 / 155	107 / 145	99 / 135
... at engine speed [rpm]	1,800 - 1,900			
Rated power ECE R120 ³¹ Power Management ³² in Field / Road mode [kW/hp(CV)]	121 / 165 / 128 / 174	118 / 160 / 128 / 174	114 / 155 / 123 / 167	103 / 140 / 113 / 154
Rated power ECE R120 ³¹ [kW/hp(CV)]	110 / 150	107 / 145	99 / 135	92 / 125
... at engine speed [rpm]	2,200			
Maximum torque Power Management ³² [Nm @ 1,500 rpm]	740	700	700	637
Maximum torque [Nm @ 1,500 rpm]	650	650	605	560
Torque rise standard / Power Management ³² [%]	40 / 40	40 / 37	40 / 42	40 / 43
Fuel tank, diesel Standard (Option) / urea [litres]	250 (210) / 39.5			
TRANSMISSION				
CVXDrive - Continuously variable transmission 50 kph ECO or 40 kph ECO	●			
Powershuttle	●			
Rear axle diff-lock type	Multi disc wet plate with management system			
Service brake	Hydraulically operated multiple wet disc brake, self adjusting			
POWER TAKE OFF				
Type	Shiftable with progressive electro-hydraulic engagement. Auto-PTO optional			
Speeds Standard (Option)	540 / 540E / 1,000 (540E / 1,000 / 1,000E) with optional ground drive			
... at engine speeds Standard (Option) [rpm]	1,969 / 1,546 / 1,893 (1,592 / 1,893 / 1,621)			
Shaft type	1 3/8" 21 splines			
FRONT PTO AND FRONT HITCH				
Front PTO 1,000 speed @ 1,895 rpm	○			
Front hitch max. lift capacity [kg]	3,100			
FOUR-WHEEL DRIVE AND STEERING (DRIVELINE)				
Type	Electro-hydraulic with Auto 4WD and Auto Differential lock*			
Front axle suspension	○			
Min. turning radius ³³ track setting 1,830 mm [m]	4.6			
HYDRAULIC SYSTEM				
System type	Variable displacement, pressure flow compensated pump			
Max. pump flow rate / system pressure [l/min / bar]	150 / 210			
Control type	Electronic Hitch Control (EHC) with cushion ride control			
Max. lift capacity [kg]	7,864			
OECD lift capacity through range @ 610 mm [kg]	5,284			
Max. number of rear remote valves Standard (Option)	Up to 4 electrical remote valves, power beyond (up to 4 mechanical remote valves, power beyond)			
Max. number of mid mount valves with electronic joystick	3 electr.			
Remote valve timer control	0 - 30 seconds on all models			
Category type	Cat II / III			
Slip control	○			
STANDARD TYRES ⁴⁾				
Front	480/65 R28			
Rear	600/65 R38			
WEIGHT / DIMENSIONS ³⁾				
Approximate shipping weight standard / suspended front axle [kg]	5,020 / 5,320	4,890 / 5,190		
Permissible total weight Class 4 [kg]	9,500 / 10,500			
A: Max. length with front and rear lower links down standard / suspended front axle [mm]	5,137 / 5,189			
B: Total height (low roof / standard cab / suspended cab) [mm]	2,887 / 3,005 / 3,025			
C: Total width across rear fenders with 150 mm extension [mm]	2,470			
D: Wheel base standard / suspended front axle [mm]	2,642 / 2,684			
E: Height at centre of rear axle, highest point low roof / standard cab / suspended cab [mm]	2,012 / 2,130 / 2,150			
F: Track setting front / rear [mm]	1,580-2,256 / 1,430-2,134			

● Standard Equipment ○ Optional Equipment

³¹ECE R120 correspond to ISO 14396 and 97 / 68 / EC

³²Power Management is only available during mobile PTO and haulage applications

³³With standard tyres

⁴⁾Other tyres on request

MODELS	MAXXUM 150 MULTICONTROLLER	MAXXUM 145 MULTICONTROLLER	MAXXUM 135 MULTICONTROLLER	MAXXUM 125 MULTICONTROLLER
ENGINE	FPT			
Number of cylinders / Capacity [cm ³]	6 / 6,728	4 / 4,485		
Type / Emission level	Common Rail Diesel engine, turbocharger and HI-eSCR2 only exhaust after treatment / Stage V			
Maximum power ECE R120 ³¹ Power Management ³² [kW/hp(CV)]	129 / 175	129 / 175	124 / 169	114 / 155
Maximum power ECE R120 ³¹ [kW/hp(CV)]	116 / 158	114 / 155	107 / 145	99 / 135
... at engine speed [rpm]	1,800 - 1,900			
Rated power ECE R120 ³¹ Power Management ³² in Field / Road mode [kW/hp(CV)]	121 / 165 / 128 / 174	118 / 160 / 128 / 174	114 / 155 / 123 / 167	103 / 140 / 113 / 154
Rated power ECE R120 ³¹ [kW/hp(CV)]	110 / 150	107 / 145	99 / 135	92 / 125
... at engine speed [rpm]	2,200			
Maximum torque Power Management ³² [Nm @ 1,500 rpm]	740	700	700	637
Maximum torque [Nm @ 1,500 rpm]	650	650	605	560
Torque rise standard / Power Management ³² [%]	40 / 40	40 / 37	40 / 42	40 / 43
Fuel tank, diesel Standard (Option) / urea [litres]	250 (210) / 39.5			
TRANSMISSION				
ActiveDrive 8 - 24x24 8-speed Powershift (40 kph / Economy 40 kph / 50 kph)	● / ○ / ○			
ActiveDrive 8 - 48x48 8-speed Powershift with creeper (40 kph / Economy 40 kph / 50 kph)	○ / ○ / ○			
Powershuttle	●			
Rear axle diff-lock type	Multi disc wet plate with management system			
Service brake	Hydraulically operated multiple wet disc brake, self adjusting			
POWER TAKE OFF				
Type	Shiftable with progressive electro-hydraulic engagement. Auto-PTO optional			
Speeds Standard (Option)	540 / 540E / 1,000 (540E / 1,000 / 1,000E) with optional ground drive			
... at engine speeds Standard (Option) [rpm]	1,969 / 1,546 / 1,893 (1,592 / 1,893 / 1,621)			
Shaft type	1 3/8" 21 splines			
FRONT PTO AND FRONT HITCH				
Front PTO 1,000 speed @ 1,895 rpm	○			
Front hitch max. lift capacity with 86 l/min / 150 l/min pump [kg]	2,800 / 3,100			
FOUR-WHEEL DRIVE AND STEERING (DRIVELINE)				
Type	Electro-hydraulic with Auto 4WD and Auto Differential lock*			
Front axle suspension	○			
Min. turning radius ³³ track setting 1,830 mm [m]	4.6			
HYDRAULIC SYSTEM				
System type Standard (Optional)	Fix displacement pump (Variable displacement, pressure flow compensated pump)			
Max. pump flow rate / system pressure Standard (Optional) [l/min / bar]	86 / 190 (150 / 210)			
Control type	Electronic Hitch Control (EHC) with cushion ride control			
Max. lift capacity 86 l/min / 150 l/min pump [kg]	7,115 / 7,864			
OECD lift capacity through range @ 610 mm 86 l/min / 150 l/min pump [kg]	4,781 / 5,284			
Max. number of rear remote valves Standard (Option)	Up to 4 electrical remote valves, power beyond (up to 4 mechanical remote valves, power beyond)			
Max. number of mid mount valves with electronic joystick Standard (Option)	3 electr. (2 mechan.)			
Remote valve timer control	0 - 30 seconds on all models			
Category type	Cat II / III			
Slip control	●			
STANDARD TYRES ⁴⁾				
Front	480/65 R28			
Rear	600/65 R38			
WEIGHT / DIMENSIONS ³⁾				
Approximate shipping weight standard / suspended front axle [kg]	5,020 / 5,320	4,890 / 5,190		
Permissible total weight Class 4 [kg]	9,500 / 10,500			
A: Max. length with front and rear lower links down standard / suspended front axle [mm]	5,137 / 5,189			
B: Total height (low roof / standard cab / suspended cab) [mm]	2,887 / 3,005 / 3,025			
C: Total width across rear fenders with 150 mm extension [mm]	2,470			
D: Wheel base standard / suspended front axle [mm]	2,642 / 2,684			
E: Height at centre of rear axle, highest point low roof / standard cab / suspended cab [mm]	2,012 / 2,130 / 2,150			
F: Track setting front / rear [mm]	1,580-2,256 / 1,430-2,134,500			

● Standard Equipment ○ Optional Equipment

³¹ECE R120 correspond to ISO 14396 and 97 / 68 / EC

³²Power Management is only available during mobile PTO and haulage applications

³³With standard tyres

⁴⁾Other tyres on request

MODELS	MAXXUM 150	MAXXUM 145	MAXXUM 135	MAXXUM 125	MAXXUM 115
ENGINE	FPT				
Number of cylinders / Capacity [cm ³]	6 / 6,728		4 / 4,485		
Type / Emission level	Common Rail Diesel engine, turbocharger and HI-eSCR2 only exhaust after treatment / Stage V				
Maximum power ECE R120 ³⁾ Power Management ²⁾ [kW/hp(CV)]	129 / 175	129 / 175	124 / 169	114 / 155	107 / 145
Maximum power ECE R120 ³⁾ [kW/hp(CV)]	116 / 158	114 / 155	107 / 145	99 / 135	92 / 125
... at engine speed [rpm]	1,800 - 1,900				
Rated power ECE R120 ³⁾ Power Management ²⁾ [kW/hp(CV)]	121 / 165	118 / 160	114 / 155	103 / 140	96 / 131
Rated power ECE R120 ³⁾ [kW/hp(CV)]	110 / 150	107 / 145	99 / 135	92 / 125	85 / 116
... at engine speed [rpm]	2,200				
Maximum torque Power Management ²⁾ [Nm @ 1,500 rpm]	740	700	700	637	590
Maximum torque [Nm @ 1,500 rpm]	650	650	605	560	528
Torque rise standard / Power Management ²⁾ [%]	40 / 40	40 / 37	40 / 42	40 / 43	41 / 42
Fuel tank, diesel Standard (Option) / urea [litres]	210 (250) / 39.5				
TRANSMISSION					
ActiveDrive 4 - 16x16 4-speed Powershift (40 kph)	● / ○				
ActiveDrive 4 - 32x32 4-speed Powershift with creeper (40 kph)	○				
ActiveDrive 4 - 17x16 4-speed Powershift (Economy 40 kph or 50 kph)	●				
Powershuttle	●				
Rear axle diff-lock type	Multi disc wet plate with management system				
Service brake	Hydraulically operated multiple wet disc brake, self adjusting				
POWER TAKE OFF					
Type	Shiftable with progressive electro-hydraulic engagement. Auto-PTO optional				
Speeds Standard (Option)	540 / 540E / 1,000 (540E / 1,000 / 1,000E) with optional ground drive				
... at engine speeds Standard (Option) [rpm]	1,969 / 1,546 / 1,893 (1,592 / 1,893 / 1,621)				
Shaft type	1 3/8" 21 splines				
FRONT PTO AND FRONT HITCH					
Front PTO 1,000 speed @ 1,895 rpm	○				
Front hitch max. lift capacity with 86 l/min / 121 l/min pump [kg]	2,800 / 3,100				
FOUR-WHEEL DRIVE AND STEERING (DRIVELINE)					
Type	Electro-hydraulic with management system, differential lock as standard				
Front axle suspension	○				
Min. turning radius ³⁾ track setting 1,830 mm [m]	4.6				
HYDRAULIC SYSTEM					
System type Standard (Optional)	Fix displacement pump (Variable displacement, pressure flow compensated pump)				
Max. pump flow rate / System pressure Standard (Optional) [l/min / bar]	86 / 190 (121 / 210)				
Control type	Electronic Hitch Control (EHC) with cushion ride control				
Max. lift capacity 86 l/min / 121 l/min pump [kg]	7,115 / 7,864				
OECD lift capacity through range @ 610 mm, with 86 l/min / 121 l/min pump [kg]	4,781 / 5,284				
Max. number of rear remote valves	Up to 4 mechanical remote valves, power beyond				
Max. number of mid mount valves with electronic joystick	2 mechan.				
Category type	Cat II / III				
Slip control	○				
STANDARD TYRES ⁴⁾					
Front	480/65 R28				
Rear	600/65 R38				
WEIGHT / DIMENSIONS ³⁾					
Approximate shipping weight standard / suspended front axle [kg]	5,020 / 5,320		4,890 / 5,190		
Permissible total weight Class 4 [kg]	9,500 / 10,500				
A: Max. length with front and rear lower links down standard / suspended front axle [mm]	5,137 / 5,189				
B: Total height (low roof / standard cab / suspended cab) [mm]	2,887 / 3,005 / 3,025				
C: Total width across rear fenders with 150 mm extension [mm]	2,470				
D: Wheel base standard / suspended front axle [mm]	2,642 / 2,684				
E: Height at centre of rear axle, highest point low roof / standard cab / suspended cab [mm]	2,012 / 2,130 / 2,150				
F: Track setting front / rear [mm]	1,580-2,256 / 1,430-2,134				

● Standard Equipment ○ Optional Equipment - Not available

¹⁾ ECE R120 correspond to ISO 14396 and 97 / 68 / EC

²⁾ Power Management is only available during mobile PTO and haulage applications

³⁾ With standard tyres

⁴⁾ Other tyres on request

⁵⁾ According to ASABE S301.5

⁶⁾ Factory installed or with front loader option for dealer installation

MODELS	T RANGE				
	MAXXUM 115 - 150	MAXXUM 115 - 150	MAXXUM 115 - 150	MAXXUM 115 - 150	MAXXUM 115 - 150
	L4522T	L4225T	L4223T	L4023T	L4020T
Self-levelling type	Hydraulic self-levelling	Hydraulic self-levelling	Hydraulic self-levelling	Hydraulic self-levelling	Hydraulic self-levelling
Loader working pressure [bar]	210	210	210	210	210
LIFT HEIGHTS					
A1: Maximum lift height at implement pivot pin ⁵⁾ [mm]	4,566	4,129	4,129	4,021	4,021
B1: Maximum lift height under horizontal bucket ⁶⁾ [mm]	4,284	3,847	3,847	3,739	3,739
C1: Clearance under dumped bucket at max dumped angle [mm]	3,678	3,241	3,241	3,133	3,133
D1: Maximum reach at lift height / tyres (bucket at 45° dumped position) [mm]	604	960	960	1,042	1,042
WORKING ANGLES					
E1: Maximum dumped angle ⁵⁾ [°]	56	56	56	56	56
F1: Reach with bucket on ground ⁵⁾ [mm]	2,631	2,533	2,533	2,397	2,397
G1: Maximum rollback angle ⁵⁾ at ground level [mm]	50	51	51	51	51
DIGGING DEPTH					
H1: Digging depth ⁵⁾ [mm]	209	232	232	206	206
LIFTING CAPACITY					
Lift capacity to maximum height - at implement pivot ⁵⁾ [kg]	2,565	3,076	2,666	2,757	2,366
Lift capacity to 1.5 m height - at pivot point ⁵⁾ [kg]	2,708	3,324	2,895	3,026	2,610
Breakout force at pivot pin ⁵⁾ [kg]	2,861	3,583	3,119	3,296	2,842
Bucket rollback force at maximum height ⁵⁾ [kg]	2,399	2,532	2,532	2,578	2,093
Bucket rollback force at ground level ⁵⁾ [kg]	2,891	2,839	2,839	2,765	2,247
CYCLE TIME					
Raising time [sec.]	6.4	7.0	6.2	6.2	5.4
Lowering time [sec.]	4.1	4.8	4.0	4.0	3.2
Bucket dumped time from crowded position at max height [sec.]	3.3	3.3	3.3	2.7	2.7
Bucket rollback time at ground level [sec.]	2.5	2.5	2.5	2.5	1.9
FEATURES					
Loader ready frame ⁶⁾	●	●	●	●	●
3rd hydraulic function	●	●	●	●	●
MACH 2 [®] (for 3rd function implement coupling)	●	●	●	●	●
4th hydraulic function	○	○	○	○	○
MACH 2 [®] (for 4th function implement coupling)	○	○	○	○	○
SHOCK ELIMINATOR [®] System	●	●	●	●	●
Electrical On / Off switch Shock Eliminator	○	○	○	○	○
MACH System [®]	●	●	●	●	●
FITLOCK 2+ System [®]	●	●	●	●	●
EURO QUICK ATTACH IMPLEMENT CARRIER	●	●	●	●	●
MX QUICK ATTACH IMPLEMENT CARRIER	○	○	○	○	○
OTHER QUICK OPTIONS: MX – EURO, EURO – SMS, MX – FAUCHEUX WHITE, EURO – TENNAS, EURO – SIGMA 4	○	○	○	○	○
FAST-LOCK System [®] (for EURO or MX QUICK ATTACH)	○	○	○	○	○
AUTO-UNLOAD System [®]	○	○	○	○	○
PCH SYSTEM [®] - Hydraulic self-levelling system	●	●	●	●	●
Mechanic self-levelling (MSL)	-	-	-	-	-

MODELS	U RANGE					
	MAXXUM CVXDrive 100 - 130	MAXXUM CVXDrive 100 - 130	MAXXUM CVXDrive 100 - 130	MAXXUM CVXDrive 100 - 130	MAXXUM CVXDrive 100 - 130	MAXXUM CVXDrive 100 - 130
	L4522U	L4222U	L4219U	L4022U	L4018U	L4015U
Self-levelling type	Mechanical self-levelling	Mechanical self-levelling	Mechanical self-levelling	Mechanical self-levelling	Mechanical self-levelling	Non-self-levelling
Loader working pressure [bar]	210	210	210	210	210	210
LIFT HEIGHTS						
A1: Maximum lift height at implement pivot pin ⁵⁾ [mm]	4,566	4,127	4,127	4,021	4,021	4,021
B1: Maximum lift height under horizontal bucket ⁶⁾ [mm]	4,284	3,845	3,845	3,739	3,739	3,739
C1: Clearance under dumped bucket at max dumped angle [mm]	3,678	3,239	3,239	3,133	3,133	3,133
D1: Maximum reach at lift height / tyres (bucket at 45° dumped position) [mm]	604	964	964	1,043	1,043	1,043
WORKING ANGLES						
E1: Maximum dumped angle ⁵⁾ [°]	56	56	56	56	56	56
F1: Reach with bucket on ground ⁵⁾ [mm]	2,631	2,533	2,533	2,397	2,397	2,397
G1: Maximum rollback angle ⁵⁾ at ground level [mm]	50	51	51	51	51	51
DIGGING DEPTH						
H1: Digging depth ⁵⁾ [mm]	209	232	232	206	206	206
LIFTING CAPACITY						
Lift capacity to maximum height - at implement pivot ⁵⁾ [kg]	2,825	2,882	2,485	2,951	2,547	2,561
Lift capacity to 1.5 m height - at pivot point ⁵⁾ [kg]	2,714	2,957	2,541	3,092	2,662	2,676
Breakout force at pivot pin ⁵⁾ [kg]	2,881	3,194	2,745	3,377	2,906	2,922
Bucket rollback force at maximum height ⁵⁾ [kg]	2,394	2,722	2,211	2,670	2,168	2,093
Bucket rollback force at ground level ⁵⁾ [kg]	2,598	2,780	2,258	2,628	2,134	2,247
CYCLE TIME						
Raising time [sec.]	6.4	6.2	5.4	6.2	5.4	5.4
Lowering time [sec.]	4.1	4.0	3.2	4.0	3.2	3.2
Bucket dumped time from crowded position at max height [sec.]	1.0	0.9	0.7	0.9	0.8	1.3
Bucket rollback time at ground level [sec.]	1.3	1.2	1.0	1.3	1.1	2.0
FEATURES						
Loader ready frame ⁶⁾	●	●	●	●	●	●
3rd hydraulic function	●	●	●	●	●	●
MACH 2 [®] (for 3rd function implement coupling)	●	●	●	●	●	●
4th hydraulic function	○	○	○	○	○	○
MACH 2 [®] (for 4th function implement coupling)	○	○	○	○	○	○
SHOCK ELIMINATOR [®] System	●	●	●	●	●	●
Electrical On / Off switch Shock Eliminator	○	○	○	○	○	○
MACH System [®]	●	●	●	●	●	●
FITLOCK 2+ System [®]	●	●	●	●	●	●
EURO QUICK ATTACH IMPLEMENT CARRIER	●	●	●	●	●	●
MX QUICK ATTACH IMPLEMENT CARRIER	○	○	○	○	○	○
OTHER QUICK OPTIONS: MX – EURO, EURO – SMS, MX – FAUCHEUX WHITE, EURO – TENNAS, EURO – SIGMA 4	○	○	○	○	○	○
FAST-LOCK System [®] (for EURO or MX QUICK ATTACH)	○	○	○	○	○	○
AUTO-UNLOAD System [®]	-	-	-	-	-	-
PCH SYSTEM [®] - Hydraulic self-levelling system	●	●	●	●	●	●
Mechanic self-levelling (MSL)	-	-	-	-	-	-

	1	2	3
	Maxxum CVXDrive	Maxxum Multicontroller	Maxxum
CVXDrive Continuously Variable transmission	●	-	-
ActiveDrive 8 transmission	-	●	-
ActiveDrive 4 transmission	-	-	●
Mechanical remote valves	○	○	●
Electrical remote valves	●	●	-
86 l/min OCLS pump	-	●	●
121 l/min CCLS pump	-	-	○
150 l/min CCLS pump	-	●	-
Cab with low roof / standard roof	○ / ●	○ / ●	● / ○
Deluxe air suspension seat	●	●	●
Dual motion seat	○	○	○
Maximo Evolution alcantara leather seat	○	○	-
Multicontroller armrest	●	●	-
AFS AccuGuide / AFS AccuTurn Pro	○ / ○	○ / ○	-
Headland Management Control II (HMC II)	●	●	-
ISOBUS III	●	●	-
Advanced trailer brake	●	-	-

● Standard Equipment
○ Optional Equipment
- Not available

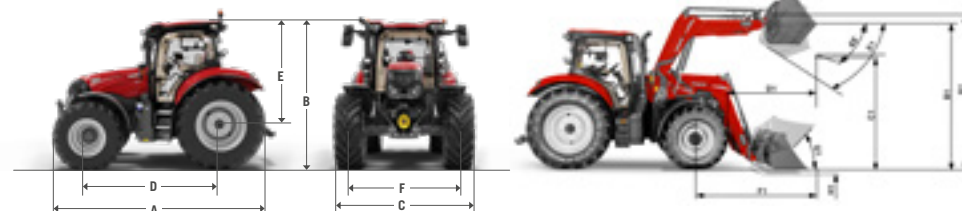
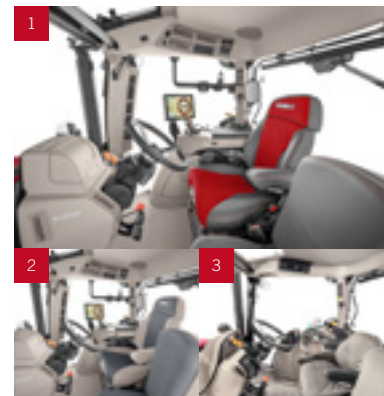



   
caseih.com

 Free phone: 00 800 22 73 44 00

Safety never hurts! Always read the Operator's Manual before working with any equipment. Inspect equipment before using it, and be sure it is operating properly. Follow the product safety signs, and use any safety features provided. This literature has been published for worldwide circulation. The standard and optional equipment and the availability of individual models may vary from one country to the next. Case IH reserves the right to undertake modifications without prior notice to the design and technical equipment at all times without this resulting in any obligation whatsoever to make such modifications to units already sold. Whilst every effort is made to ensure that the specifications, descriptions and illustrations in this brochure are correct at the time of going to press, these are also subject to change without prior notice. Illustrations may show optional equipment or may not show all standard equipment. Case IH recommends **AKCELA** lubricants.

TP01 / SM / 11.22 / Printed in Austria - Cod.No. 22C0013COMINB

CASE IH