

AXIAL-FLOW® 50 SERIES COMBINES

AXIAL-FLOW 50 SERIES COMBINES



CASE IH

CASE IH



AXIAL-FLOW 50 SERIES COMBINES

5 Models | 150 Series: Class 6, 7 | 250 Series: Class 7, 8, 9

HARVEST MORE OF WHAT YOU GROW

Case IH offers the industry's largest lineup of combines to meet the needs of any operation. From header to spreader, the Axial-Flow 50 series combines are designed to be reliable and preserve the quality of over 134 grain types, to simply harvest more of what you grow.

“Today, everything we touch, look at, or use costs more. And one thing that costs the most is time. These combines are important to our operation from an economic stance, in that we can effectively, gently harvest seed and popcorn in a timely fashion. That’s the bottom line—getting the crop from the field to the bin. And Case IH Axial-Flow combines help us to do that.”

Zack Tanner, Tanner Seed Farms



AXIAL-FLOW 50 SERIES COMBINES

Axial-Flow Family	4-5	Threshing and Separating	24-25
Find Your Perfect Flow	6-7	SCR Technology	26-27
Leading the Industry	8-9	150 Series Combines	28-33
Advanced Farming Systems (AFS)	10-11	250 Series Combines	34-41
AFS Harvest Command™	12-15	Residue Management	42-43
4400 Series Corn Heads	16-17	Heads	44-45
3100 Series II Draper Heads	18-19	PowerFlex Trax System	46-47
Operator Environment	20-21	Dimensions/Tires/Tracks	48-49
Proven Performance	22-23	Product Specifications	50-51



MEET THE INDUSTRY'S LARGEST SINGLE ROTOR LINEUP

Case IH provides **the broadest combine offering to meet the needs of any operation**, including two Class 7 models so producers can tailor a machine to their unique needs. From the hardworking, simple Class VI Axial-Flow 6150 with 411 peak horsepower all the way up to the powerful Class IX Axial-Flow 9250 that peaks at 625 horsepower, you will find an Axial-Flow combine perfectly suited for your operation's needs. From header to spreader, Axial-Flow series **systems are carefully matched to ensure efficiency and productivity**. The Axial-Flow line represents **simplicity and reliability** with the **fewest drive components** and **longest service intervals in the industry**. It also features one of the largest cleaning systems in the industry, the most innovative drive systems and the largest selection of heads.





CORE PRINCIPLES OF AXIAL-FLOW COMBINES:

SIMPLICITY

Axial-Flow combines are designed with **fewer moving parts** for unmatched reliability and easier serviceability.

CROP ADAPTABILITY

Designed to **harvest over 134 types of grains** in many conditions. The Axial-Flow combine is versatile enough to match your diverse harvesting needs.

MATCHED CAPACITY

Controlling crop flow is the key to harvesting success. The Axial-Flow feeder, rotor, grain handling, residue management and power systems are designed to **optimize crop flow and maximize productivity.**

GRAIN QUALITY

Gentle grain-on-grain threshing is the hallmark of the Axial-Flow design. From feeding to cleaning, the entire system is **designed to minimize grain damage.**

GRAIN SAVINGS

Axial-Flow combines pave the way for savings. Thorough threshing and efficient separation **put more grain in the tank** and more profits in your pocket.

RESALE VALUE

Case IH combines reward their owners with impressive resale value. A wide variety of kits are also available to enhance performance, upgrade technology, boost productivity and **maximize your investment.**

150 SERIES COMBINES



HARVEST MORE OF WHAT YOU GROW

At harvest, you have one goal: **ensuring an effortless flow of grain from the field to the bin.** Case IH Axial-Flow combines are engineered for matched capacity to deliver proven grain savings. The industry-leading single rotor design **ensures grain quality and increased productivity.** And the new AFS Harvest Command automation can even optimize harvest settings on the go to match your harvest conditions—further **enhancing productivity and reducing operator fatigue.**

KEEP EFFICIENCY FLOWING SMOOTHLY

Axial-Flow 150 and 250 series combines build on the Case IH legacy of high capacity and high efficiency, helping you to **maximize throughput, optimize grain quality** and harvest more of what you grow.

AXIAL-FLOW 150 SERIES COMBINES

Increase productivity and boost your yields during harvest season. Case IH Axial-Flow 150 series **combines feature legendary single rotor technology, Cross Flow™ cleaning system and increased grain handling capacity** to help you put more high-quality grain in the tank.

HIGH LEVEL SPECIFICATIONS

	6150	7150
Type - Tier 4b Final	Case IH - FPT	
Horsepower - Rated per SAE	348 hp (260 kW)	375 hp (280 kW)
Total Cleaning System Area Under Wind Control - sq. in.	8,556 - Fixed 8,370 - CrossFlow	
Fixed or Self Leveling Cleaning System	Both	
Grain Tank Capacity - Std	300 bu.	
Unloading Speed	3.2 bu./sec.	

250 SERIES COMBINES



AXIAL-FLOW 250 SERIES COMBINES

Case IH Axial-Flow 250 series combines are engineered to make the most of harvest — with advanced features such as **2-speed electric shift ground drive transmission, adjustable rotor cage vanes, improved feeder house design and optional AFS Harvest Command combine automation system.**

OPTIMIZE YOUR HARVEST WITH AFS HARVEST COMMAND

Harvest at peak efficiency with the AFS Harvest Command combine automation system, available in 250 series combines. This advanced technology **simplifies harvest by proactively sensing and optimizing machine settings** to maximize grain quality and grain savings, regardless of operator skill level.

	7250	8250	9250
Type - Tier 4b Final	Case IH - FPT		
Horsepower - Rated per SAE	402 hp (299 kW)	480 hp (358 kW)	550 hp (410 kW)
Total Cleaning System Area Under Wind Control - sq. in.	10,075		
Fixed or Self Leveling Cleaning System	Self Leveling		
Grain Tank Capacity - Std	315 bu.	410 bu.	
Unloading Speed	4.0 bu./sec.	4.5 bu./sec.	



SIMPLICITY IS AT THE HEART OF EVERY CASE IH ROTARY COMBINE

Axial-Flow single rotor technology has led the industry since 1977, providing a simple design that **produces superior grain quality and a better value than any other combine on the market.**

PRODUCTIVITY OF AXIAL FLOW COMBINES

The productivity of Axial-Flow combines is dependent on several variables: type of crop, crop conditions, timeliness of harvest, machine settings, and operator experience. Machine capacity may vary, depending on conditions. The average productivity difference between each Axial-Flow model ranges 10% to 20%.

The AFS Harvest Command combine automation system further increases productivity and simplifies your harvest by proactively sensing and optimizing machine settings to maximize grain quality and grain savings – regardless of operator skill level.

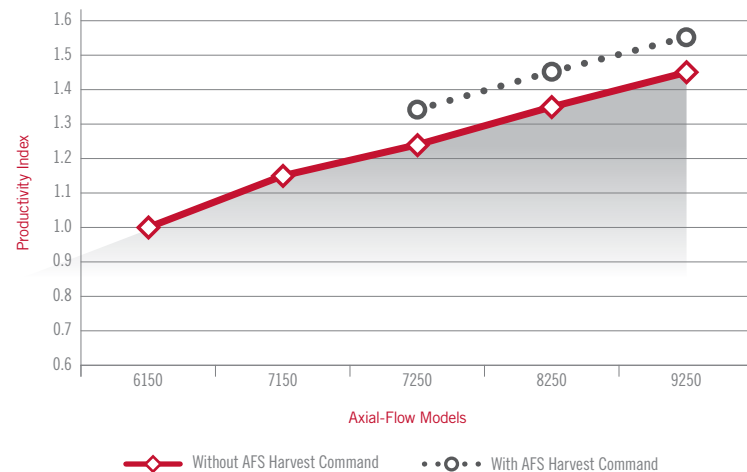

Chart based on 2019 field tests



MODEL	6150	7150	7250	8250	9250
CLASS SIZE	CLASS 6	CLASS 7	CLASS 7	CLASS 8	CLASS 9
Engine	Case IH – FPT 8.7 L		Case IH – FPT 11.1 L	Case IH – FPT 12.9 L	Case IH – FPT 16.0 L
Rated Power	348 hp	375 hp	402 hp	480 hp	550 hp
Peak Power	411 hp	442 hp	468 hp	555 hp	625 hp
Power Rise	63 hp	67 hp	66 hp	75 hp	
Feeder Width	45.5 in. (1.16 m)			54 in. (1.37 m)	
Concave Wrap	156.5°			180°	
Cleaning System	Fixed/Cross Flow™			Self-Leveling to 12.1%	
Cleaning Area	8,556 sq. in. (5.5 m²) Fixed / 8,370 sq. in. (5.4 m²) Cross Flow			10,075 sq. in. (6.9 m²)	
Grain Tank Size	300 bu.			410 bu.	
Unload Rate	3.2 bu./sec		4.0 bu./sec	4.5 bu./sec	
Rotor Drive	3.0 in. (76.2 mm) rotor belt			Power Plus CVT Drive	
AFS Pro 700					



FIELD SOLUTIONS

Monitor, map and evaluate your crop's performance to help maximize profit and yield. Compare yield and moisture data with prior yield maps to determine what factors or operations will maximize future yields. If you're not in the driver's seat during harvest, you can **monitor your harvesting data remotely through AFS Connect to help make recommendations to the team that will help maximize efficiencies.**

FIELD SOLUTIONS

- **AFS AccuSync** ensures all your operators are working together efficiently by sharing coverage maps and A/B guidance lines in real time.
- **Yield and Moisture** monitoring and mapping capabilities display harvest data in the cab. The detailed harvest data is recorded to help make decisions to **improve current yield and maximize future yield potential.**
- **AFS AccuGuide™ autoguidance** provides hands-free steering to achieve and **maintain accurate row positioning** in ever-changing harvest conditions and **ease operator fatigue** during long hours of operation. Case IH offers various guidance corrections from sub-meter to sub-inch tailored to your operation and farming practices.
- **AFS Variety Tracking** connects spring planting maps to the combine to **analyze seed variety performance** using data from planting in conjunction with **yield and moisture data tracked at harvest** — up to 30 different varieties per field.
- **Auto-Cut Width** adjusts combine cut width when traveling through **odd-shaped fields**, point rows or previously harvested areas to provide accurate yield reading and postharvest yield maps to give you the tools to best plan for next year's crop management programs.

AFS CONNECT

AFS Connect allows you to precisely manage your operation anywhere from a computer, phone or tablet.

- **Farm and Fleet Management:** Coordinate unloading, maintenance and refueling to make the most of tight harvesting windows. Efficiently plan your day by sharing guidance lines and field boundaries with multiple pieces of equipment.
- **Visualize Data:** Create and upload field boundaries with custom layers—from planting/seeding to harvesting. Aggregate data from multiple machines in one field and visualize actionable layers of agronomic data. Upload yield data direct from the field with a subscription or via USB with a free AFS Connect account, giving you flexibility to manage, share, and view your data.
- **Harvest Tracking:** enter scale ticket information to track grain from field to storage.

- **Harvest Summary:** provides varieties, average yield and total bushels harvested by field.
- **Layer reports:** view available map layers by field, including wet/dry yield and moisture.
- **Yield by Variety:** sort yield data by variety to quickly compare hybrid performance across your operation.
- **Geofence and Curfew Notifications:** Receive notifications straight to your mobile device to notify you when a machine enters or exits a field or is running outside of your designated operating hours.
- **Data Sharing:** Transfer harvesting data. Securely share information to farm managers, dealers or trusted partners as you choose.
- **AFS Connect Farm App:** View and monitor your equipment and field information in one place, all on your mobile device or tablet.

EQUIPMENT INFORMATION AT YOUR FINGERTIPS

When you have questions about Case IH equipment maintenance, there's no time to lose getting back in the field. My.CaseIH.com is your destination for Case IH product support, including free operators manual downloads, AFS training videos, how-to tutorials and maintenance tips to help you through questions or situations you encounter every day.

Create a free My.CaseIH.com account and use the same login credentials to access the features of the AFS Connect app today!



My **CASE IH**



AFS HARVEST COMMAND COMBINE AUTOMATION: THE FUTURE OF HARVESTING

Significant advancements in automation on the 250 series Axial-Flow combine lead the way in the future of harvesting technology. AFS Harvest Command automation proactively adjusts the combine as crop conditions change using exclusive, patent-pending technology to help inexperienced operators achieve the productivity of an expert operator. AFS Harvest Command automation is officially supported for the following crop types: **corn, soybeans, canola, barley, wheat and rice.**

ALWAYS OPTIMIZING FOR MAXIMUM PRODUCTIVITY

CHOOSE FROM FOUR MODES OF AUTOMATION TO FIT YOUR OPERATION

- **Performance:** Maximize grain savings and grain quality while optimizing throughput.
- **Grain quality:** Maximize grain quality while also saving grain and optimizing throughput.
- **Max throughput:** The operator can maximize throughput while automation adjusts combine settings to save grain.
- **Fixed throughput:** The operator can fix the machine throughput and the machine will adjust to save grain and maintain a quality sample.

MAKE EVERY DRIVER AN EXPERT OPERATOR

Fine-tuning harvest settings and adjustments can test even the most experienced operator. AFS Harvest Command automation helps refine the harvesting process by reducing the number of functions you need to monitor in the cab from twelve to three. **With AFS Harvest Command, you control concave clearance, header position, and grain tank unload while the automation system takes care of the rest.**



QUANTIFY YOUR PERFORMANCE

With AFS Harvest Command, further **dial in your machine with the new sensitivity adjustments.** For rotor, sieve, grain quality and material other than grain sensitivities, the operator can now **observe machine performance** to easily dial in machine sensitivities and machine performance while using AFS Harvest Command.



“Labor is important. Whether you’ve run a combine for 50 years or 50 minutes, this machine is super user-friendly. The fact you can grab someone off the street and get the same results as someone who has run one forever is extremely appealing to us.”

Mark Bartlett, Colby, Kansas
Running an Axial-Flow 8250 combine with 3162 draper head.

AVAILABLE ON
**250 SERIES
 COMBINES**

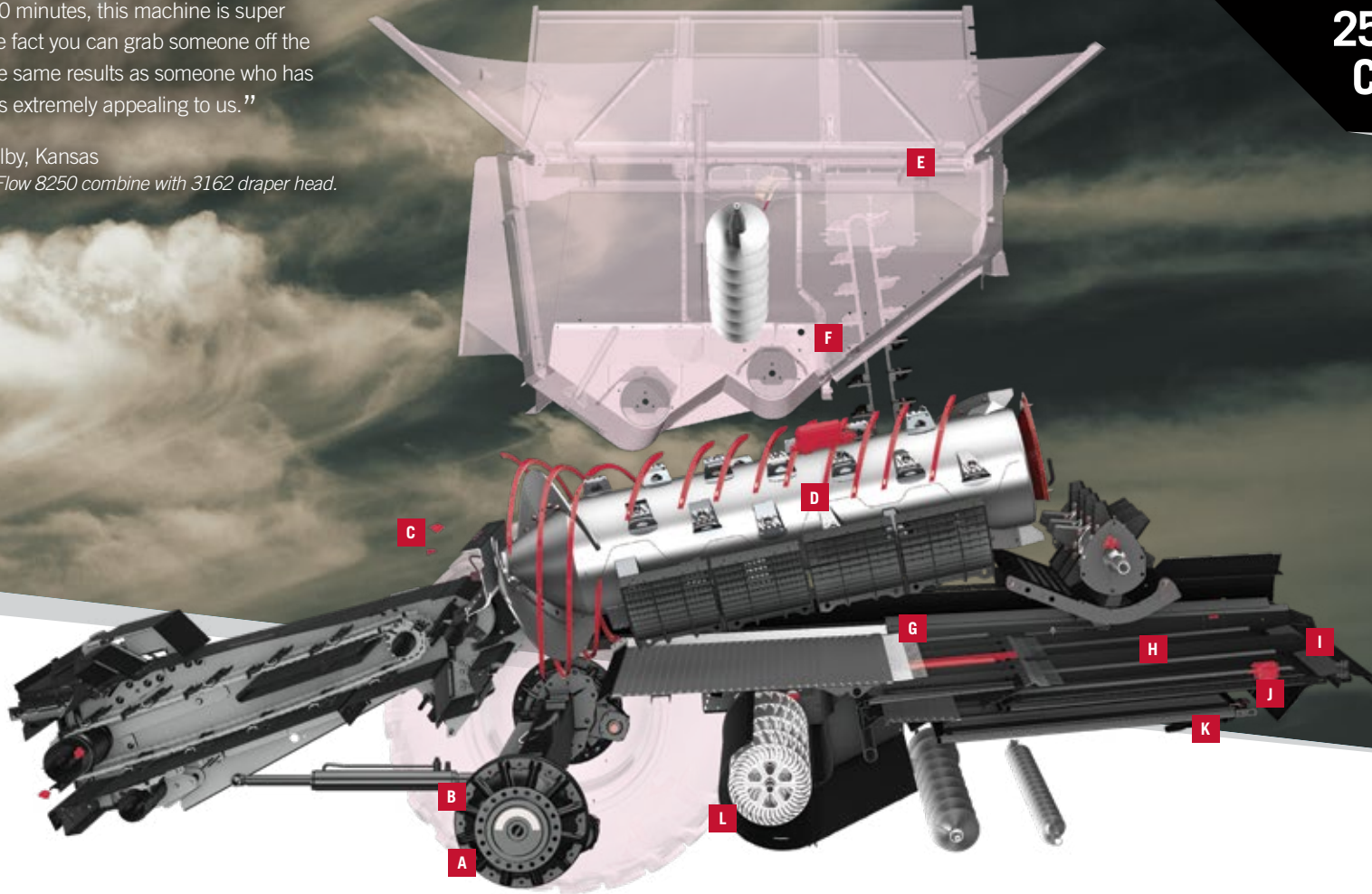

16 SENSORS MONITORED BY AFS HARVEST COMMAND

AFS Harvest Command **automatically adjusts seven machine settings** (ground speed, rotor speed, cleaning fan speed, presieve, upper sieve, lower sieve, cage vane angle) **based upon 16 sensor inputs and comprehensive algorithms to maximize productivity and grain quality and to minimize losses.**

- A** Ground Speed Sensor
- B** Ground Drive Pressure Sensor
- C** Inclination Sensor
- D** Cage Vane Position Sensor
- E** Flow/Yield Sensor
- F** Grain Camera
- G** Presieve Position Sensor
- H** Upper Sieve Position Sensor
- I** Sieve Loss Sensor
- J** Sieve Pressure Sensors
- K** Lower Sieve Position Sensor
- L** Fan Speed Sensor

Not shown:

- Engine Load Sensor
- Rotor Speed Sensor
- Rotor Loss Sensors
- Tailings Volume Sensor



AUTOMATION TO FIT YOUR OPERATION

Regardless of the time of day, crop conditions, or moisture levels, simply choose the appropriate AFS Harvest Command mode of automation to match your harvesting situation. Each automation mode prioritizes different harvesting outcomes — from grain quality to grain savings to throughput — and continually optimizes machine performance based on the operator's goals.

PERFORMANCE MODE

- **Situation:** the harvest season is progressing well. Conditions are nearly ideal, with no weather threats looming.
- **Goal:** maximize grain savings and grain quality while optimizing throughput.

GRAIN QUALITY MODE

- **Situation:** you want to earn premiums for food-grade grains or seed crops.
- **Goal:** achieve maximum grain quality in the tank while also saving grain and optimizing throughout.

MAX THROUGHPUT MODE

- **Situation:** the harvest is at a critical juncture and the forecast is a concern. You need to maximize the acres you harvest each day without sacrificing grain loss or quality.
- **Goal:** maximize the throughput, and the machine will adjust to save grain and maintain a quality sample.

FIXED THROUGHPUT MODE

- **Situation:** Steady progress wins the harvest. Your workforce includes less-experienced combine operators. Rather than asking those operators to fine-tune settings and operations—potentially leading to unacceptable grain loss or damage—set a consistent, steady pace and maximize your quality of work and optimize grain delivery to the dryer.
- **Goal:** fix the machine throughput, and the machine will adjust to save grain and maintain a quality sample.

FIRST-TIME USER REACTION:

Hear what influencers have to say about the Case IH 250 series Axial-Flow combine featuring AFS Harvest Command technology as they experience it first-hand in the field.

“So this combine’s got the new, I don’t even know what you call it. **It’s the auto everything mode. It’s the Millennial mode.** Must be a millennial mode combine. **It controls everything on the go by my understanding. Cause I’m not really having to do much here. It’s doing the work.** Looks like it will control the threshing speed and the clearances. It speeds up and slows down as we get to greener spots and tougher spots. Awesome.”

— Zach, Millennial Farmer

“**Watching this monitor here is pretty fun...** I’m going head on into the wind, but I was originally going completely with the wind, so it was blowing up the back of the combine. This thing had the fan cranked to almost 1,200 RPM. It was like 1,150, which I think is about full fan speed. And, now I turned around I’m heading north into the wind, it dropped the fan by about 100 RPM, maybe 150. My thoughts are, because the air from the wind was pressurizing the backside of the combine, it saw it needed more pressure to force the chaff out the back, versus driving into the wind, now all the sudden that pressure is not on the back of the combine, so it doesn’t need the fan cranked as much. **An operator probably wouldn’t do that, ‘cause they wouldn’t know what they’re changing when they do that. Very cool.**”

— Nick, Welker Farms

“...But I am actually cutting probably at least a mile to two mile an hour faster than him...see how I’m past him here? **And the only reason it’s doing that is because this combine can handle it because the automation.** He can’t go any faster because if he does he’s gonna throw grain out the back and his sample gonna get bad. And this is the thing that’s just really impressed us the most about this combine is **how much more this combine can cut** than those.”

— Nick, Welker Farms

“**That was our first experience with an automatic combine and we really like that.** That something that whatever combine we get next would have on. That and **the cab was really nice.** Seemed like it was a little quiet.”

— Brian, Brian’s Farming Videos



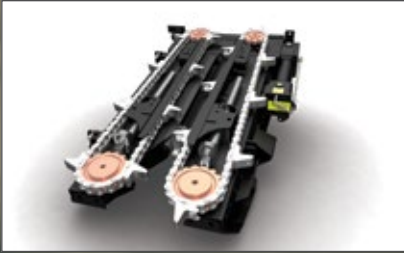

A large, open **front-gathering chain sprocket** sweeps stalks efficiently into rolls and helps harvest downed cornstalks.



Pinching stalk rolls power feed the cornstalk directly into the path of the chopping blade and consistently deliver a 3- to 6-inch chop length.



Grain-saving, **patented CornLouvers™** direct grain back toward the auger to ensure loose grain makes it into the combine.

SETTING THE HARVEST BENCHMARK AND PIONEERING COMPATIBILITY WITH 4400 SERIES CORN HEADS

Case IH headers set the **industry benchmark** for corn harvesting and provide the greatest **return on your investment**. The 4400 series corn heads are designed to harvest more efficiently, better matching today's higher-horsepower combines and **faster harvest speeds**. From the stalk roll spirals, to the diameter and length of the stalk rolls, to the speeds of the gathering chains and the gearboxes, the headers are carefully matched, allowing you to pick each kernel of corn at **faster ground speeds and in adverse conditions**.

CASE IH CORN HEADERS ARE DESIGNED TO PICK CLEANER

From the profile of the dividers and hoods to the length and speed of the stalk rolls, every aspect of the corn head is designed to cleanly pick and **gently move ears into the feeder house**.

- Pinching-style stalk rolls are designed to cleanly pull the stalks through the row unit and deck plates and gently snap the ear off the stalk to minimize grain loss.
- The deck plates gently curve downward, matching the ear's profile and significantly reduce yield loss due to shattered corn falling from the deck plate to the ground.
- The chrome alloy **pinching-style stalk rolls** precisely crimp the stalks to aid in material decomposition for better residue management. Optimum grain threshing is achieved with less material other than grain (MOG) processing through the combine.





Case IH offers folding corn heads in 8-row and 12-row configurations. Capable of **folding into transport mode in less than a minute**, folding heads dramatically improving transport efficiency, and, ultimately, field productivity.

Replaceable wear strips are easy to service, keeping you in the field during optimal harvest windows.

Heavy-duty drives with aluminum gear case housing reduce weight and increase strength by 20% for high-speed harvest.



CORN HEAD MODEL	4406	4408	4408 Folding	4412	4412 Narrow Row	4412 Folding	4416*	4416* Narrow Row	4418* Narrow Row
Spacing	30 in. (762 mm)/ 36 in. (914 mm)/38 in. (965 mm)		30 in. (762 mm)		20 in. (508 mm)/ 22 in. (559 mm)		30 in. (762 mm)		20 in. (508 mm)/ 22 in. (559 mm)
Configuration	Nonchopping/chopping								
Combine Model Compatibility	88, 130, 140, 150 series	88, 130, 140, 150, 10, 20, 230, 240, 250 series		6088, 7088, 6130, 7130, 6140, 6150, 7140, 7150, 10, 20, 230, 240, 250 series	10, 20, 230, 240, 250 series		8120, 9120, 8230, 9230, 8240, 8250, 9240, 9250 series		

*Requires heavy-duty feeder drive.



A **seed saver channel** along the bottom of the draper belt smoothly pulls grain into the combine, saving up to 3%.



The new **air bag suspension system** for the center section provides improved flotation and improved range of rotation. Torsion blocks enable the operator to adequately adjust cutterbar pressure for even the most adverse conditions, such as soft fields and wet harvest conditions.

HARVEST MORE OF WHAT YOU GROW WITH CASE IH DRAPER HEADS

The ability to cover more acres per day equals increased productivity. Get harvesting earlier and run later at night with increased speed with Case IH 3100 Series II TerraFlex™ draper headers. These headers are designed to provide **head-first feeding for smooth, consistent crop flow**, performing more efficiently in adverse, high-moisture harvest conditions. Case IH offers **rigid drapers for small grain harvesting** and **TerraFlex drapers for following ground contours**, both available in a wide range of cutting widths to match the capacity of your Axial-Flow combine.

- **Infeed improvements** include a rubber-covered drive roll for increased traction, “V” guide seals to prevent seeds from migrating inside the belt loop and a rock stripper on the back roll to prevent belt stalling.
- A standard **hydraulic fore and aft header tilt** allows the header to closely follow ground contours — even in changing field conditions. Changing header tilt and optimizing the guard angle is easily accomplished from the cab.
- The **stainless-steel infeed floor plate** improves feeding into the combine, including in heavy, damp harvest conditions.

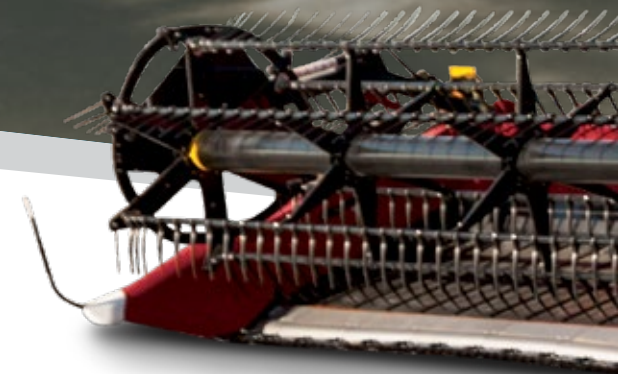



Knife heads, spline blocks, knife arms and hardware have been substantially beefed up to improve reliability and durability. More robust knife heads include a factory-assembled and lubed knife arm and head vertically mounted, allowing adjustments as required to obtain the proper gearbox-to-cutterbar spacing.

An industry-exclusive **low-speed transport system** (25 mph or less) allows the operator to deploy the transport package with the touch of a button, saving time when moving from field to field.



- **TerraFlex draper headers** feature a cutterbar capable of flexing up and down 3 inches for a 6-inch range of travel. This added flexibility improves access to beans lower in the canopy, increasing yield potential by as much as 10%.
- The PTO connection to the combine feeder output shaft now features a **21-tooth spline**, handling increased loads of larger capacity header models.
- Rigid drapers feature a shorter cutterbar-to-drafter distance than competitive headers for smooth, even delivery of crop onto the draper belts.



AXIAL-FLOW COMBINE CABS

Thanks to your input, Case IH has taken one of **the largest, most comfortable combine cabs** in the industry and made it even better, providing the ultimate in convenience, comfort and productivity for **your office in the field.**

COMFORT, CONTROL AND CONNECTABILITY

- Slide rail console.
- Standard AFS Pro 700 display.
- Cellphone cradle with **USB power port** — easy reach and readability.
- **Separate power outlet.**
- Optional cloth or redesigned highback leather seat with a comfort plus pad.

- **Auto Clean** helps the producer clean out the machine between crop types with a simple button press within the AFS Pro 700
- Standard Bluetooth® radio.
- **AFS Connect compatible modem and subscription come standard** to support machine and agronomic data transfer on new Axial-Flow combines.

REFINED MULTIFUNCTION HANDLE

- Moves with seat for **smooth operator control.**
- **Similar function grouping** at your fingertips.
- **Multiple settings** easily saved for future use.
- **Configurable** header raise and lower buttons.
- Optional cross auger control.

- Optional **pivoting spout.**
- Optional **feeder faceplate** fore/aft adjustment.

INSTRUCTIONAL SEAT WITH PORTABLE FRIDGE

- **Instructional seat** backrest flips down to create a work surface.
- Double duty — side seat serves as **work surface or lunch cooler.**
- Portable fridge **included in luxury cab package.**
- **Portable fridge can be removed** to take home to clean and repack for the next day.
- Fridge comes with **two power cords** — one for the vehicle and one for the combine.





HIGH-EFFICIENCY HARVEST STARTS HERE

The 150 and 250 series Axial Flow combines use industry-leading engineering design to give you more productivity with minimal loss and grain damage. It starts with the revolutionary single-rotor design, high-capacity cleaning system and easy serviceability so you can harvest more of what you grow.

ADVANCING SINGLE-ROTOR DESIGN

The AFX rotor features constant **pitch impellers that draw the crop and air into the rotor**. The AFX rotor can be set in many configurations, adapting to both crop and threshing conditions with the use of **straight bars, spiked rasp bars and helical kickers**. Competitive rotor and cage designs can reduce productivity and increase grain damage because of inefficient feeding and crop-control designs.

- **Adjustable cage vanes.** Available on the 250 series, optional **in-cab adjustable cage vanes** adapt the threshing system to changing loads and crop conditions. This helps **maximize throughput and optimize grain savings.**

CLEAN SAMPLES, MINIMAL LOSS

Axial-Flow combines lead the industry in cleaning area. In each class size, the Axial-Flow cleaning area is larger, delivering **cleaner samples with minimal losses** and matched capacity.

AUTOMATIC CROP SETTINGS

For 150 and 250 series models, Automatic Crop Settings provide up to **10 different machine settings and 80 factory crop presets**. Each crop type can contain multiple user-defined work conditions, all of which can be transferred between machines.

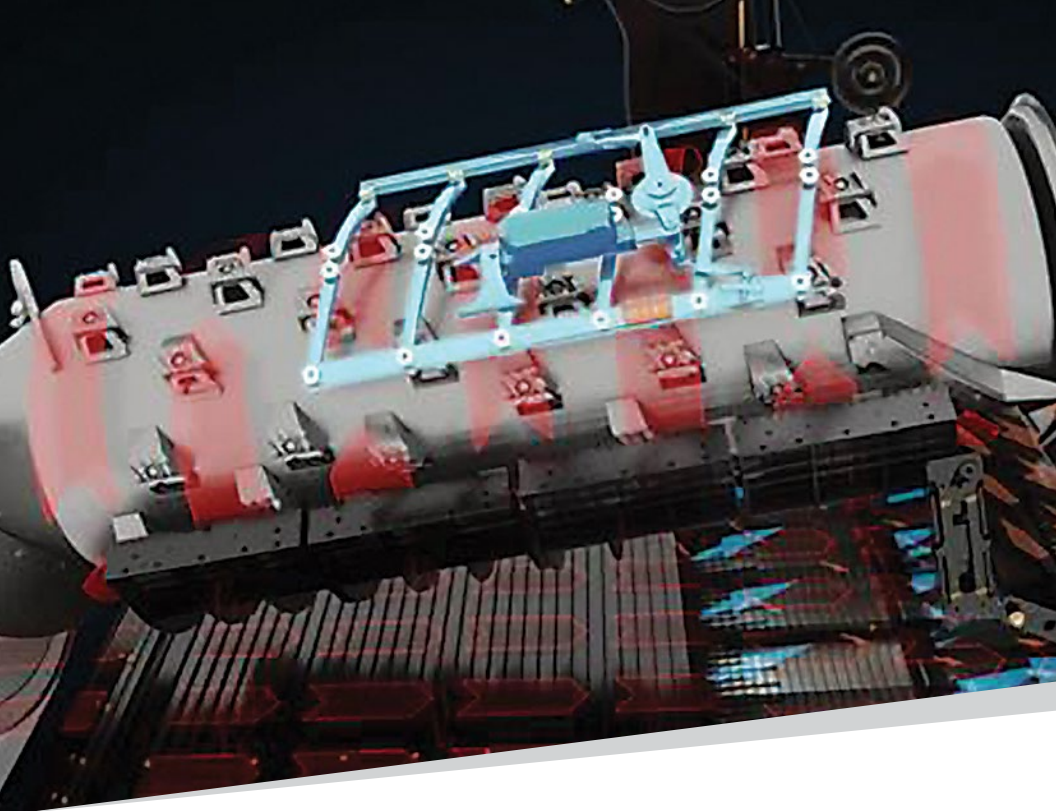

AUTO CLEANING FAN SYSTEM

- This new feature **automatically adjusts the fan RPM speed when the combine is operating on a slope** (uphill or downhill) to keep the grain from being lost out the back of the combine. Automatically adjusting the fan speed minimizes grain loss and maximizes combine productivity.

CLEANING SYSTEM SIZE

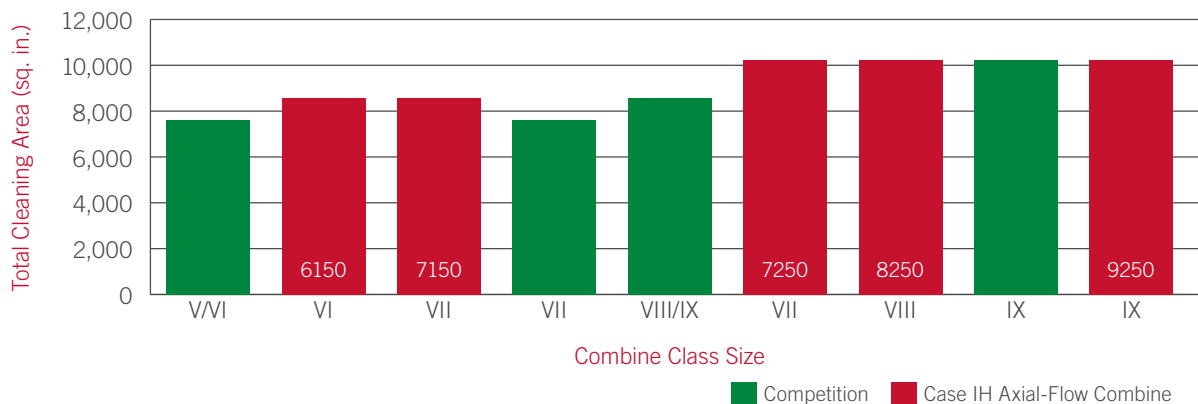

MAINTENANCE MADE EASY

With convenient access to essential areas like the hydraulics, batteries, filters, radiator and cooling system, minor maintenance can be performed quickly and easily. Thanks to the SCR-only engine technology, one oil is used for all hydraulic operations and only needs to be **changed every 600 hours**. There are fewer belts and chains to adjust and maintain, as well as convenient side inspection doors, handrails, service lights and nonskid surfaces on all platforms. The Power Plus™ CVT drives on the 250 series mean less routine maintenance thanks to only three drive chains and six belts on the entire machine.

INSIDE THE AXIAL-FLOW COMBINE

We pioneered rotor development back in the 1960s. Since then, refinements, enhancements and improvements have led to the pinnacle in rotor performance: the AFX rotor. It features constant pitch impellers that draw the crop and air into the rotor. The AFX rotor can be set into many configurations, adapting to both crop and threshing conditions with the use of straight bars, spiked rasp bars and helical kickers. Competitive rotor and cage designs can reduce productivity and increase grain damage because of inefficient feeding and crop-control designs.

TRANSITION CONE

- **Axial-Flow transition cone: the most patented feature.** The transition cone is the most patented feature of the Axial-Flow. Its simple geometry transitions crop from feeder to rotor. Crop is smoothly accelerated in a spiral motion from 5 mph to about 60 mph.
- **Feeder sizes to match combine capacity.** Axial-Flow feeders produce a thick crop mat and utilize rolled-slat feeder chains for aggressive feeding with minimal grain damage. The enhanced crop flow results in improved rotor performance and machine productivity.

THE CONCAVE/MODULE WRAP

- **The proof is in the grain tank.** Concave/module wrap is one of the most important elements affecting combine capacity. While other brands use longer rotors, Case IH uses the concave/module wrap to gain capacity. All Case IH combines use a 30-inch diameter rotor. The Axial-Flow 150 series uses 156 degrees of concave wrap while the 250 series utilize 180 degrees of module wrap.

AFX ROTOR

- **The most advanced rotor technology.** The single in-line AFX rotor coupled with a concentric rotor cage delivers gentle, multiple pass, grain-on-grain threshing and smoother crop flow – the hallmark of an Axial-Flow combine.

The AFX rotor uses constant pitch impellers, rasp bars and helical kickers to efficiently move crop through the machine for more complete threshing and greater productivity. The constant pitch impellers provide more capacity, using less horsepower and less fuel.
- **AFX rotor module options.** Different rotor modules on the Axial-Flow 250 series can be used to easily adapt to a variety of harvesting conditions. Rotor modules are composed of two sections, right and left, and are interchangeable front to back. The 40-lb. modules are secured with just two bolts and can easily be switched within minutes.

The small tube (ST) rotor is standard for rice and optional for small grain producers. This rotor provides increased productivity in tough harvest conditions where rice or tough green straw would be present.

CONCENTRIC ROTOR CAGE

- **Customized for peak performance.** Adjustable rotor vanes can be used to optimize crop flow and maximize productivity. Axial-Flow combines can be adjusted to provide uniform crop flow with more efficient use of power. Maintaining crop control also reduces peak horsepower demands and consumes less fuel.
- **Greater crop separation.** Concentric rotor cage provides positive crop control and is perforated to allow maximum crop separation (up to 360 degrees) from the centrifugal force of the innovative AFX rotor.

ACTIVE GRAIN PAN

- **Maximize your productivity.** Designed for extra capacity, an active grain pan is utilized on the Axial-Flow 250 series. The active grain pan helps stratify material, leaving the heavy seeds at the bottom of the pan and the lighter MOG (material other than grain) at the top. When the layers move onto the sieves, the grain falls and the MOG is lifted in the air by the Cross-Flow fan.

A The **transition cone** smoothly transitions crop from feeder to rotor.

B The **concentric rotor cage** provides positive crop control and allows maximum crop separation.

C **Adjustable rotor vanes** provide the ability to control crop flow in the rotor cage.

D The **Cross-Flow fan** provides superior air flow across the entire sieve.

E The **active grain pan** moves grain and material other than grain (MOG) to the cleaning system. The grain pan stratifies the grain from the MOG starting the separation process before it reaches the cleaning system.

F The **AFX rotor** efficiently moves crop through the machine.

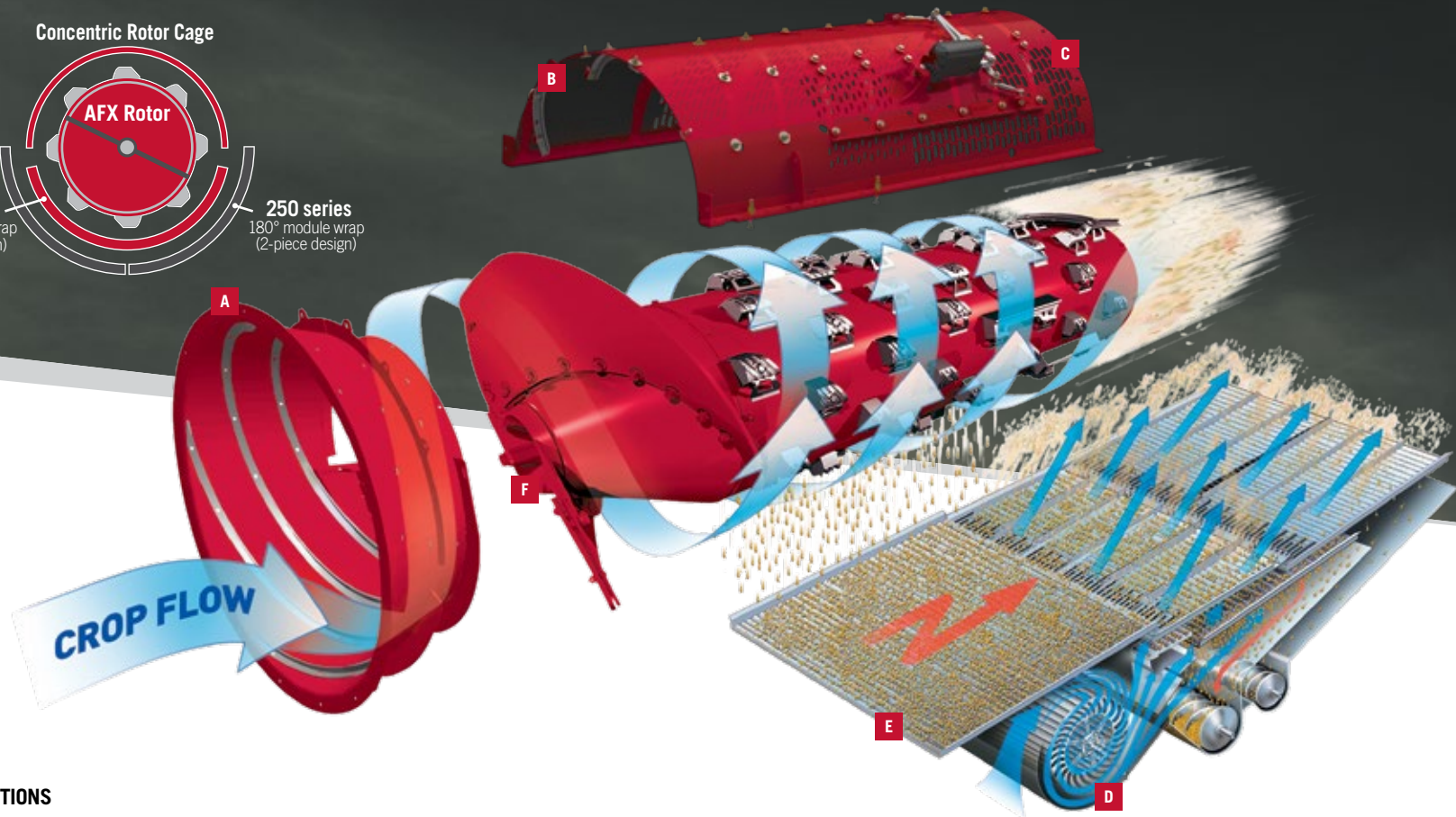
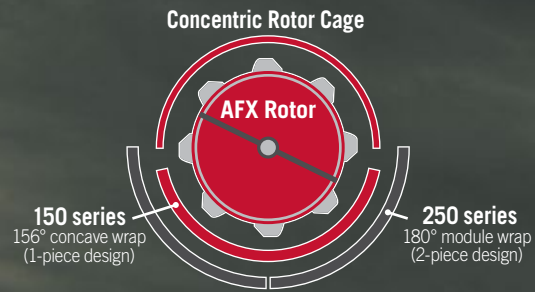

MODULE OPTIONS

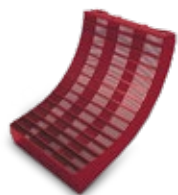

Small Wire
Small grain



Hard-to-Thresh Kit
Cereal grains



Large Wire
Corn, soybeans & rice



Slotted
Edible beans & sunflowers



Round Bar
High-moisture corn & rice
(16 mm std./25 mm opt.)



Large Skip Wire
Separating area



Solid Module
Easy threshing & separating

*Axial-Flow 250 series AFX rotor configuration shown with optional straight bars.

PATENTED CASE IH EMISSIONS SOLUTION

Case IH was the first to deliver innovative SCR-only technology. This patented technology lets Case IH achieve Tier 4 B/Final standards without adding Exhaust Gas Recirculation (EGR) and Diesel Particulate Filter (DPF) components to the engine system. Case IH chose SCR technology because it works outside engines and allows them to run at their best, without modification or compromise. Because it helps save diesel fuel and increase power. Because it means engines will last longer with less routine maintenance. It is the right solution, right from the start.



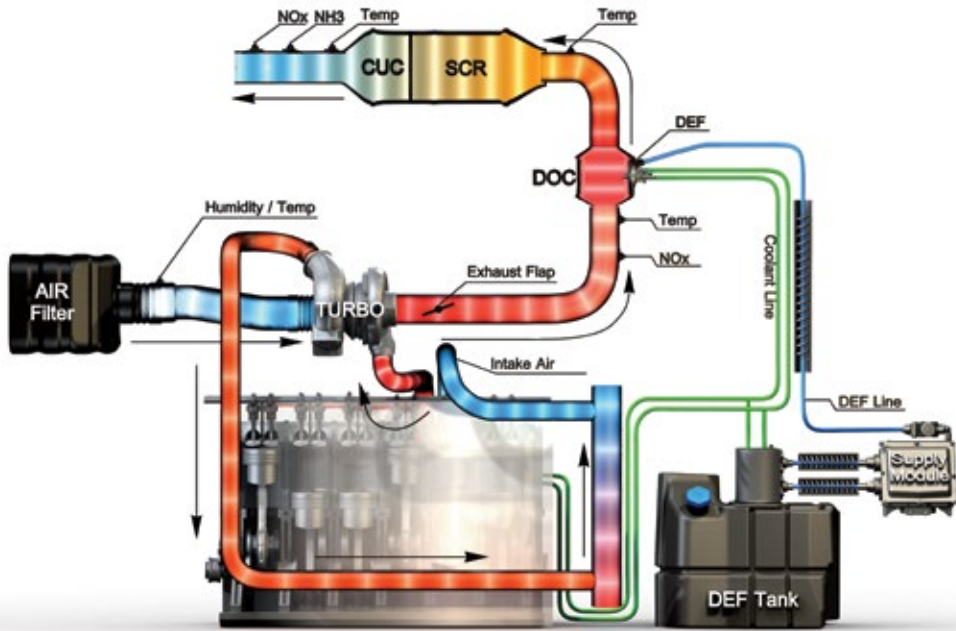

SCR-ONLY SOLUTION: CLEAN & SIMPLE

The Case IH Selective Catalytic Reduction (SCR) solution is a true exhaust after-treatment system, with all of the emissions components located on the exhaust.

- Single SCR-only solution does it all with class-leading power that does not compromise efficiency.
- Treats exhaust outside the engine, without added complexity.
- Service requirements and engine exposure to soot and carbon minimized.
- Easy to service with industry-leading 600-hour oil change.
- Patented SCR-only Tier 4 B/Final design delivers 95% NOx conversion efficiency vs. competitive systems that provide only 80% to 85% efficiency.
- Designed to optimize fuel efficiency.
- Case IH SCR-only patented engines have become the benchmark for engine technology in the agriculture industry.

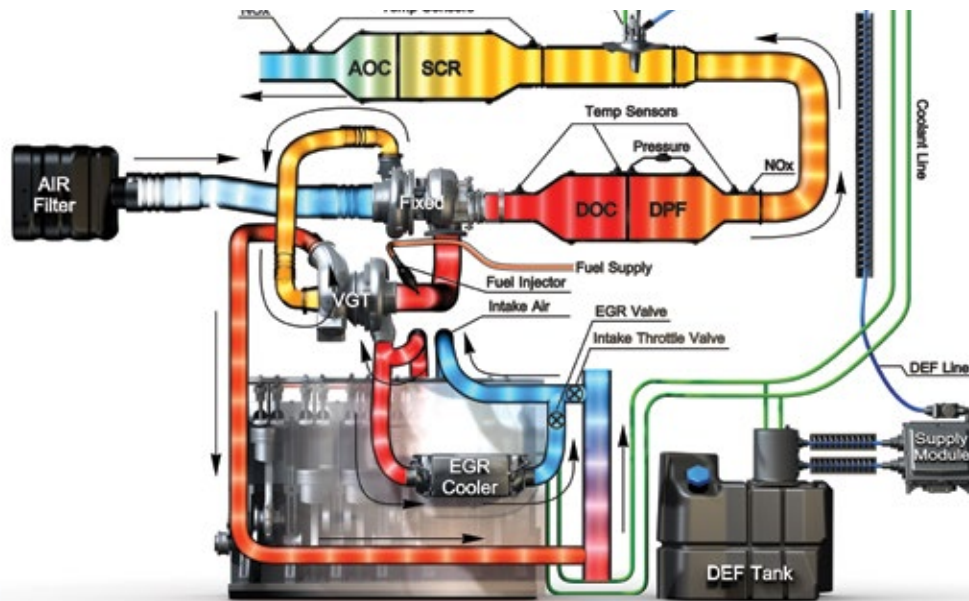

HYBRID SOLUTION: CLUTTERED & COMPLEX

If it looks a little cramped and cluttered in the engine compartment of a combine with a hybrid EGR/DPF/SCR emissions system, that's because it is.

- Competitive combines with hybrid systems are more complex, have more hardware and trap more trash and debris leading to compromised performance.
- Operating a hybrid system means compromised performance and more complexity (and heat) than ideal.
- Added engine parts throttle back power and performance.
- EGR valve means higher operating temperatures and fuel costs.
- More parts, more service, more maintenance expense.

150 SERIES AXIAL-FLOW COMBINES

Axial-Flow 150 series combines feature the legendary single-rotor technology, combined with the advancements made to the combine productivity, such as the Cross Flow cleaning system, the two-speed electric shift transmission, the increased grain-handling capacity, the hydraulically driven residue package and the option of a differential lock on the 2-speed transmission.



AXIAL-FLOW
150 SERIES

CLASS 6, 7 COMBINES



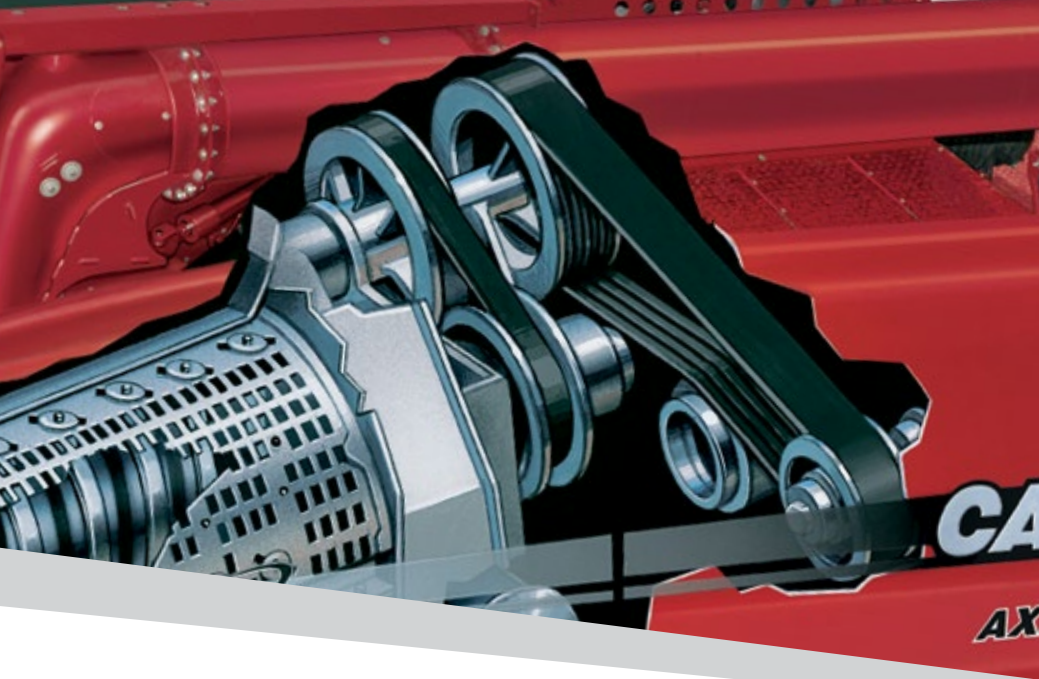

150 SERIES COMBINES HIGH-EFFICIENCY COMBINES WITH BUILT-IN ECONOMY

Perfect for owner operators and fleet operations, the 150 series Axial-Flow combines deliver **maximum peace of mind through a simple-to-operate, efficient and reliable design featuring a belt-driven rotor**. With proven Tier 4 B/Final emissions-certified 8.7-L engines, up to 375 engine horsepower at 2,100 engine RPMs and 300-bu. capacity, they give you the same superior grain quality, grain savings and value as the larger 250 series.

CROSS FLOW CLEANING SYSTEM

High-capacity combines need large, high-capacity cleaning systems. **The Cross Flow cleaning system increases productivity up to 20% and is the largest cleaning system in the industry for Class 6 to 7 combines.** Designed to

move grain more efficiently, the auger bed with six extended-wear augers helps deliver up to a maximum of 5,000 bushels per hour. The Cross-Flow fan uses its patented design to deliver consistently clean grain samples no matter the harvest condition. The Cross Flow cleaning system even compensates for hillsides—designed to maximize cleaning capacity up to 12 degrees—providing superior productivity, grain sample quality and savings regardless of the terrain.

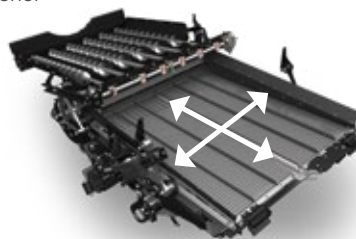

SIMPLICITY AND RELIABILITY

With extra large pulleys, the rotor drive features Kevlar™ belt technology on the 150 series combines. An exclusive **three-speed gearbox** provides maximum belt wrap while ensuring efficient power transfer from the engine to the rotor. The Axial-Flow 6150 and 7150 utilize a 3-inch. (76 mm) wide rotor drive belt. The three-speed gearbox also provides rotor speed overlap for improved belt life, while the three-speed ranges ensure optimal positioning for commonly used rotor speeds. This unique design results in less belt slippage, greater durability and increased life.



UNPARALLELED OPERATOR ENVIRONMENT

Thanks to more space and an ergonomic design, when you climb into the Case IH Axial-Flow cab, you'll get a **panoramic view** of what leadership really looks like. When the days are long and the nights are even longer, you'll come to really appreciate the **industry-leading comfort** of the Axial-Flow cab.

BIGGER TANKS

Axial-Flow 150 series combines feature large, 300 bu. (10572 L) grain tank capacities.

PIVOTING AUGER SPOUT

An **industry-exclusive pivoting spout** allows easier grain cart fill. From the comfort of the cab, the operator can reposition the unloading grain stream with a single button. The unloading spout can be positioned where needed, instead of moving the entire combine. Available on all Axial-Flow combine models.

FASTER UNLOAD RATES

Unload rates increase from **3 to 3.2 bushels** per second for the **6150 and 7150 combines**.

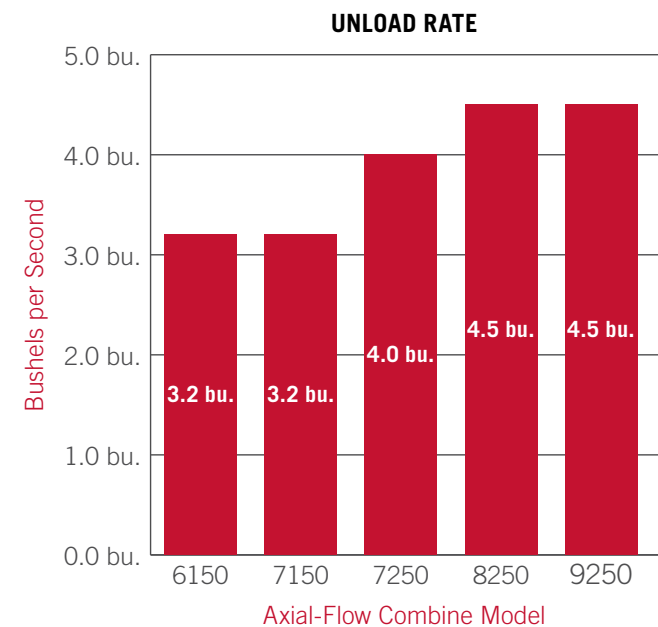

150 SERIES AXIAL-FLOW COMBINES: PROVEN PRODUCERS WITH BUILT-IN ECONOMY

Perfect for owner operators and fleet operations, the 150 series Axial-Flow combines deliver maximum peace of mind through a simple-to-operate, efficient and reliable design featuring a belt-driven rotor. With proven Tier 4 B/Final emissions-certified 6.7-L–8.7-L engines, up to **375 engine horsepower and up to 300 bushel capacity**, they give you the same superior grain quality, grain savings and value as the larger 250 series.



▲ Tall corn attachment

A 4400 SERIES CORN HEADS

- Nonchopping & chopping configurations
- New divider profile
- Optional spiral dividers and tall corn attachment
- Patented corn louvers
- Flip up hoods and dividers with hydraulic lift cylinders
- 20- to 22-in. narrow row configurations available

B FEEDER

- 3-chain/2-strand feeder chain
- Feeder drum with drum rings
- New hydraulic drive belt tensioner
- Feeder reinforcements

C 2WD STANDARD

- Optional power guide axle
- 8 single drive tire options
- 8 dual drive tire options

D DELUXE CAB

- 110 cu. ft. of space/62 sq. ft. glass
- Right-hand console groups controls by function
- AFS Pro 700 display provides operator to machine interface
- Convenient storage compartment integrated within the HVAC system provides heating/cooling for beverages

D LUXURY CAB

Includes all features of deluxe cab plus:

- Additional storage compartments
- Leather-wrapped steering wheel
- Electric/heated mirrors
- Standard portable fridge

E LIGHTING OPTIONS

- 3 available lighting packages to suit your needs
- Distance lighting package available





L AFX ROTOR

- Creates smooth crop flow
- Improves throughput
- Puts more high-quality grain in your tank
- 156 degrees of concave wrap
- New split concaves weigh 38 lb. each
- Adjustable cage vanes improve threshing and throughput

K 8,370-SQ. IN. CROSS FLOW CLEANING SYSTEM

Cross Flow cleaning system includes all of the features from the fixed cleaning system along with the following:

- Can increase productivity up to 20%
- Compensates for hillsides and is designed to maximize cleaning capacity up to 12 degrees
- Provides increased capacity even on level ground

F 300-BU. GRAIN TANK

- Standard manual fold extensions
- Optional in-cab folding extensions and covers
- Clean grain elevator can handle up to 5,000 bu. per hour

G FASTER UNLOADING AUGERS

- 6150 & 7150: 3.2 bu./sec
- Standard fixed spout, optional pivoting spout with grain saver door

H FPT TIER 4 B/FINAL SCR-ONLY ENGINES

- Responsive power and improved fuel economy
- Emissions treated in the exhaust

H RESIDUE MANAGEMENT SYSTEM

- Three chopper options: 3-bladed discharge beater; standard cut straw chopper; 6-row flail cut chopper
- Standard dual disc spreaders

J 8,556-SQ. IN. FIXED CLEANING SYSTEM

- Largest cleaning system in the industry for Class 6 through 7 combines
- Auger bed with six extended-wear augers
- Patented Cross-Flow fan (450–1,300 rpm fan range)

250 SERIES AXIAL-FLOW COMBINE — A LOOK TO THE FUTURE

With 250 series Axial-Flow combines, you get the latest advancements, without sacrifice. Case IH offers the industry's largest lineup of combines to meet the needs of any operation. From header to spreader, Axial-Flow series combines are designed to be reliable and preserve the quality of more than 134 grain types, so you can simply harvest more of what you grow.



AXIAL-FLOW
250 SERIES

CLASS 7, 8, 9 COMBINES



TECHNOLOGY TO MAKE YOUR HARVEST EASIER

The 250 series delivers superior performance and capacity. Spend less time under the unloading auger with high unload rates. Increase yield with superior grain sample quality and savings. Plus, with a large, quiet cab, you get maximum comfort and productivity engineered with agronomic and intuitive design.



FEEDER HOUSE

High-capacity features and heavy-duty feeding systems help ensure a smooth harvest. 250 series combines include optional advancements to the feeder house, such as a heavy-duty feeder lift capacity to handle up to 18-row narrow chopping corn heads, high-capacity feeder drive and fore/aft feeder faceplate tilt. Additional improvements include header height control software and improved feeder top-shaft reliability. The result is even smoother crop flow and greater durability.

Additional improvements:

- **Optional feeder faceplate fore/aft control** allows you to make adjustments from the cab.
- **Redesigned feeder top shaft drive coupler** features a crowned spline design for greatly improved durability and reliability.
- A simple **two-piece feeder floor design** reduces wear and increases durability and improves crop feeding.

2-SPEED ELECTRIC SHIFT GROUND DRIVE

- **Simplifies operation** so you can use first gear for harvest and second gear for roading.
- Delivers **wider speed ranges** for more power for climbing hills and check levies providing propulsion through challenging ground conditions.
- **Reduces the need to stop and shift** in field or on the road.
- Uses a high/low propulsion system to toggle between low and high ranges on the fly to **provide additional operator control when extra traction or change in speed is required.**
- Uses closed-loop sensing for **constant speed control** (like cruise control in a car).
- Provides **greater torque through a wider speed range** without shifting due to increased displacement of pumps and motors for challenging and wet field conditions.
- Improves traction and field performance with an **optional differential lock that is electrically actuated** and hydraulically engaged.
- Provides enhanced efficiency features to **improve fuel savings** in road mode during transport and auto-idle RPM in economy mode.

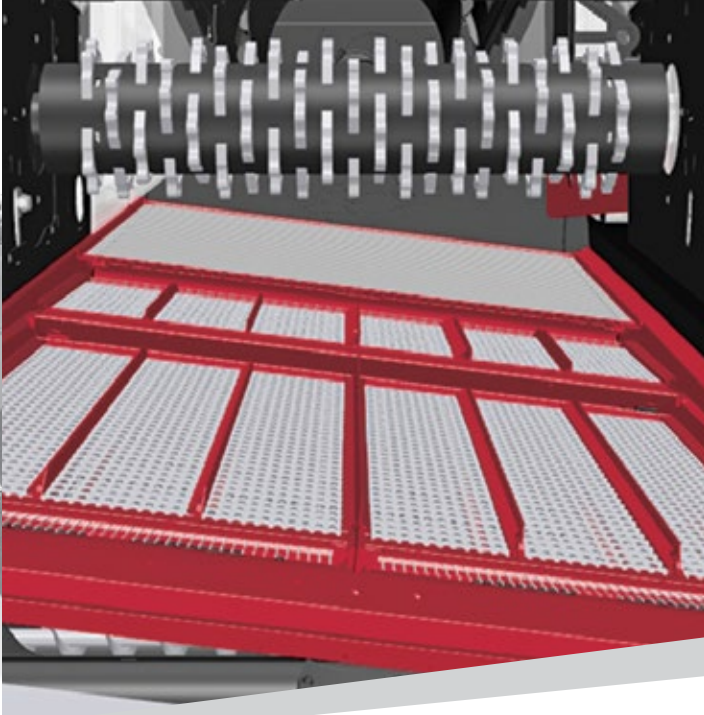

EXCLUSIVE POWER PLUS CVT COMBINE DRIVES

- The innovative Power Plus™ continuously variable transmission (CVT) combine drive features a belt-free, low-maintenance design with variable speed drives.
- An **exclusive in-cab rotor de-slug** accommodates high-volume, tough-threshing crops.
- Delivers the convenience of hydraulic variable control and the efficient power transfer of a mechanical system.
- Designed to meet the high-horsepower demands of our 250 series combines.

SELF-LEVELING CLEANING SYSTEM

- The self-leveling cleaning system (SLS), standard on Axial-Flow 250 series combines, saves grain and increases productivity on flat ground as well as on hills. The entire system (grain pan, top sieve, bottom sieve and fan) **levels itself for optimal cleaning efficiency** on flat fields or hills and banks on end row turns, minimizing potential grain loss.

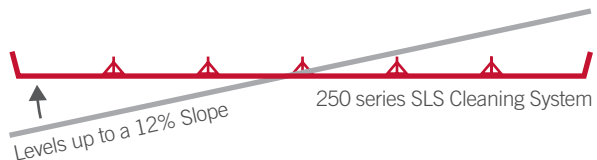

PIVOTING SPOUT AND FOLDING AUGER

- **Two folding auger options** on the 250 series provide easier transport and storage with an added benefit of a smaller footprint when opening up the field. Pivoting spout, available on all models, adjusts the flow of grain up to 3 feet without changing the position of the grain cart or combine.



A HARVEST LIKE YOU'VE NEVER SEEN

Premium LED lighting package

Every producer knows that a hard day's work on the farm isn't always from 9-to-5. That's why the new Axial-Flow 250 series combine is designed to operate whenever you need to, from the pre-dawn morning until long after the sun sets. With premium LED lighting offering better nighttime visibility and round-the-clock harvesting options, you'll be able to increase operator productivity while maximizing your harvest window.

SEE THE IMPROVEMENT

- **Stubble lights:** up to 300% light intensity improvement
- **Unload tube light:** average of 70% light intensity improvement
- **Rear work lights:** overall light intensity improvement of over 1000%
- **Common service areas:** average of 420% light intensity improvement





WATTAGE COMPARISON	MODEL YEAR 2021 (All halogen)	MODEL YEAR 2022 (All LED)
2 Stubble Lights, 1 Unload Tube, 2 Reverse	55W	50W
1 Grain Tank	16W	15W
4 Under Shield Lights, 1 Engine Deck Light	37.5W	15W
2 Sieve Lights	37.5W	15W
2 Mirror	40W LED	50W LED for increased light output
COMMON LIGHTS		
6 Main LED Headlight		36W
2 Distance/Center LED Headlight		24W
2 Distance LED		60W

250 SERIES AXIAL-FLOW COMBINES: POWER PLUS TECHNOLOGY

Producers with large acreages and crops of all types will appreciate the crop adaptability, grain quality and grain savings of the Class 7, 8 and 9 250 series Axial-Flow combines. They feature proven Tier 4 B/Final emissions-certified engines using SCR-only technology with 11.1-L, 12.9-L and industry-leading 15.9-L engines with up to **550 rated horsepower and 625 peak horsepower**. Couple that power with **410-bu. capacity** and an unload rate of up to 4.5 bu./second for the productivity you need. The 250 series includes extra features like a **self-leveling cleaning system, belt-free Power Plus CVT drive** with an in-cab de-slug feature and automatic crop settings for quick, push-button return to the machine settings you use most.



■ 3100 SERIES II DRAPER HEADS (not shown)

- Widest selection of draper heads in the industry
- 3152 rigid drapers: 25 ft. to 45 ft.
- 3162 TerraFlex™ drapers: 30 ft. to 45 ft.
- Cam action reel efficiently moves crops
- Heads-first feeding provides smooth even crop flow
- Patented CentraCut™ Knife Drive
- Wide in-line feed drapers provide extra capacity for today's wider heads and higher crop volumes
- Slow speed transport can be deployed from the cab
- Standard airbag suspension in the center section of the header further improves cutterbar floatation

■ 3162 TERRAFLEX CUTTERBAR (not shown)

- Flexes 3-in. up and 3-in. down
- Ground following capability captures low pod beans or down crop
- Simple mechanical torsion blocks provide more adjustability than conventional hydraulic systems
- TerraFlex fore/aft feeder tilt

■ A FEEDER HOUSE

- 4-chain/3-strand feeder chain
- Adjust the cutterbar to the optimum angle for feeding
- Improved feeder top shaft design for reliability and durability
- Improved design to increase crop flow and reduce wear

■ B LUXURY CAB

Includes all features of deluxe cab plus:

- Additional storage compartments
- Leather-wrapped steering wheel
- Electric/heated mirrors
- Standard portable fridge
- Optional leather seat with comfort plus pad

■ C 410-BU. GRAIN TANK

- Standard manual fold extensions
- Optional in-cab folding extensions and covers

■ D LIGHTING OPTIONS

Multiple lighting packages to suit your needs

- Optional distance lighting package available
- New premium LED lighting package



E UNLOADING AUGER LENGTH TO MATCH HEADER WIDTH

- 7250 and 8250: 4.0 bu./sec
- 8250 and 9250: 4.5 bu./sec
- Standard fixed spout, optional pivoting spout with grain saver door

F PTO GEARBOX

- Provides simple efficient power for combine and hydraulic systems
- Direct drive from engine

G CONTINUOUSLY VARIABLE TRANSMISSION DRIVES

- CVT rotor drive
- CVT feeder drive
- Patented feeder to ground speed control
- Exclusive in cab de-slug feature

H 10,075-SQ. IN. CLEANING SYSTEM

- One of the largest in the industry for Class 7 through 9 combines
- Self-leveling (up to 12%) cleaning system maximizes efficiency and grain savings
- Grain pan starts cleaning process and improves cleaning system efficiency

I RESIDUE OPTIONS

- Seven chopper and spreader options
- The 40 blade internal chopper with a new top bevel knife design cuts crop residue efficiently while promoting biological breakdown.

FPT TIER 4 B/FINAL SCR-ONLY ENGINES (not shown)

- Responsive power and improved fuel economy for demanding harvest conditions
- Emissions treated in the exhaust

AFX ROTOR (not shown)

- Available in both small-tube (27") and large-tube (30") rotor configurations
- Creates smooth crop flow
- Improves throughput
- Puts more high quality grain in your tank
- 180 degrees of concave wrap
- 7 threshing and separating module options
- Adjustable cage vanes improve threshing and throughput

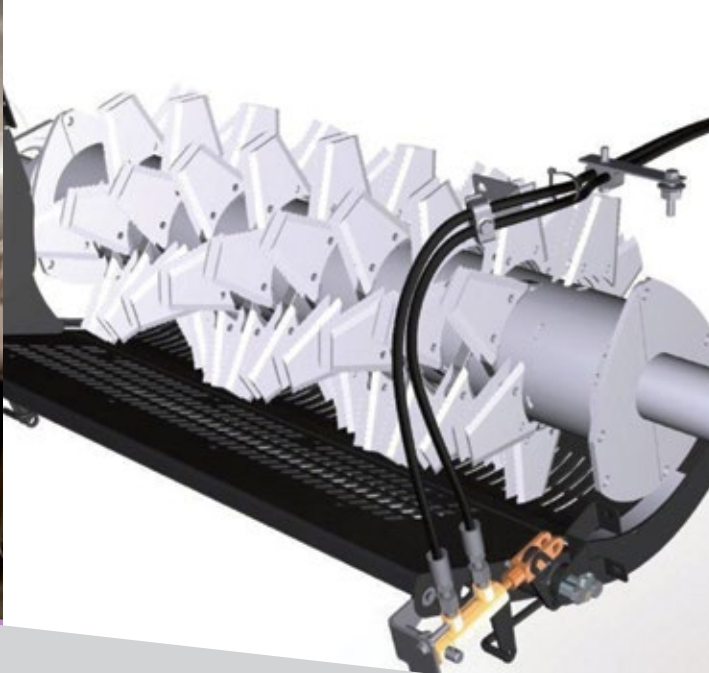

MANAGE RESIDUE EASILY AND EFFECTIVELY

The Case IH residue management system is built to handle the tough residue associated with new crop genetics. We offer the widest range of residue management features on the market to tailor residue to your tillage and livestock demands. The system delivers consistency across the larger head widths used on the Axial-Flow 250 series combines, helps prepare the ground for next year's crop and can create consistent windrow formations and long straw for baling.

AXIAL-FLOW CHOPPERS

Axial-Flow 7250, 8250 and 9250 model choppers deliver the right residue-handling system for any operation. Choose from **seven different residue packages** to match your residue requirements to your farming operation. Some packages provide the ability to switch between spreading chaff and windrowing straw – an industry first.

The optional hood-mounted external Xtra-Chop chopper on 8250 and 9250 models is fitted to the rear of the combine for fine chopping in certain small grains and cereal grain markets. Ninety-six knives and 12 fan blades chop and package the residue and spread it across the full required working width.

MAGNACUT CHOPPER

Axial-Flow 7250, 8250 and 9250 models offer the MagnaCut™ chopper option for unparalleled performance in the heaviest of crop conditions. The three-row helix design coupled with longer, more aggressive counter knives **produces the finest cut in residue** with superb adjustability to balance both cut and power consumption. The MagnaCut chopper is so unique that it was given the prestigious AE50 Award from the American Society of Agricultural and Biological Engineers.

MORE RESIDUE MANAGEMENT IMPROVEMENTS

If you're looking to enhance your field environment, uniform residue spreads are an important first step before seed, chemical and fertilizer placement. Axial-Flow 7250, 8250 and 9250 models offer spreader options with enhanced geometry for **increased width and even chaff spreading**. Easily adjust spread width with manual adjust linkage or with the option to adjust electronically from the cab on the go, so you can change residue patterns to offset crosswinds or to adjust to varying field conditions or future planting needs. A new center divider also adjusts to control the spread pattern behind the combine. In addition, the windrow opening is **45% larger** with an improved residue geometry to provide better windrow formation and material flow.

250 SERIES COMBINE RESIDUE OPTIONS

Beater/Chopper Configuration	Rotating Blades	Fixed Counter Knife Blades	Individual Counter Knife Protection	Spread Distribution	Windrow Door	Windrow Chute	Windrow Guards
MagnaCut Fine Cut		40	Standard	Manual adjust		Standard	
MagnaCut Fine Cut - Deluxe Spreader		40	Standard	In-cab electric		Standard	
MagnaCut Fine Cut - Deluxe Spreader*		40	Standard	Manual adjust		Standard	
MagnaCut Extra Fine Cut Deluxe*	120	40	Standard	In-cab electric		Standard	
MagnaCut Extra Fine Cut Deluxe	120	40	Standard	Manual adjust		Standard	
MagnaCut Fine Cut w/ Dual Disc Spreaders		40	Standard	Dual disc adjustable		N/A	
MagnaCut Fine Cut X-Tra Chop Rear Chopper		40	Standard	In-cab electric		Standard	

*Includes In-cab control of the Counter Knife bank, chopper speed and rotor discharge deflector.





THE GREATEST CHOICE OF HEADS TO GIVE YOU THE GREATEST YIELDS

Simple, reliable Case IH head designs deliver consistent performance and durability, regardless of crop or conditions. Just like the combines behind them, Case IH heads are simple to set and adjust, intuitive to operate and help you deliver more high-quality grain to the tank. With heads as wide as 45 feet, they deliver a steady stream of grain to match the high capacity of machines like the Axial-Flow 9250.



PICKUP HEAD

- **3016 Series II Pickup Head**
 - 12-, 15-ft. pickup widths
 - 1-piece belt (12-ft. width)
 - 3-piece belt (15-ft. width)
 - 88, 130, 140, 150, 10, 20, 230, 240, 250 series combine model compatibility



4400 SERIES CORN HEADS

- **4406**
 - 6-row, 30-, 36-, 38-in. spacing
 - Nonchopping/chopping configuration
 - 88, 130, 140, 150 series combine model compatibility
- **4408**
 - 8-row, 30-, 36-, 38-in. spacing
 - Nonchopping/chopping configuration
 - 88, 130, 140, 150, 10, 20, 230, 240, 250 series combine model compatibility
- **4412**
 - 12-row, 20-, 22-, 30-in. spacing
 - Nonchopping/chopping configuration
 - 6088, 7088, 6130, 7130, 6140, 6150, 7140, 7150, 10, 20, 230, 240, 250 series combine model compatibility
- **4416**
 - 16-row, 20-, 22-, 30-in. spacing
 - Nonchopping/chopping configuration
 - 8120, 9120, 8230, 9230, 8240, 8250, 9240, 9250 series combine model compatibility
- **4418**
 - 18-row, 20-, 22-in. spacing
 - Nonchopping/chopping configurations
 - 8120, 9120, 8230, 9230, 8240, 8250, 9240, 9250 series combine model compatibility



4400 SERIES FOLDING CORN HEADS

- **4408 Folding**
 - 8-row, 30-in. spacing
 - Nonchopping/chopping configuration
 - 88, 130, 140, 10, 20, 230, 240, 250 series combine model compatibility
- **4412 Folding**
 - 12-row, 30-in. spacing
 - Nonchopping/chopping configuration
 - 10, 20, 230, 240, 250 series combine model compatibility



3100 SERIES II DRAPER HEADS

- **3152 Rigid Draper Head**
 - 25-, 30-, 35-, 40-, 45-ft. cutting widths
 - CentraCut knife drive
 - 88, 130, 140, 150, 10, 20, 230, 240, 250 series combine model compatibility
- **TerraFlex 3162 Draper Head**
 - 30-, 35-, 40-, 45-ft. cutting widths
 - CentraCut knife drive
 - 88, 130, 140, 150, 10, 20, 230, 240, 250 series combine model compatibility



TERRAFLEX AUGER HEAD

- **3020 Flex Auger Head**
 - 20-, 25-, 30-, 35-ft. cutting widths
 - Single knife (20-, 25-, 30-, 35-ft. widths)
 - Double knife (30-, 35-ft. widths)
 - 88, 130, 140, 150, 10, 20, 230, 240, 250 series combine model compatibility



RIGID AUGER HEAD

- **2030 Rigid Auger Head**
 - 17-, 20-, 24-, 30-ft. cutting widths
 - Single knife
 - 88, 130, 140, 10, 20, 230, 250 series combine model compatibility



IMPROVED HARVEST PERFORMANCE IN ANY CONDITION

PowerFlex Trax™ combine systems deliver all the advantages of tracks with the added benefits of exceptional operator comfort, greater productivity and improved harvests in every condition – from wet, muddy fields and rocky soil to tight harvest windows and unforeseen challenges.

This fully suspended system allows you to access wet fields early and improve harvest speeds over rough terrain in unparalleled comfort. Vibration and shock reduction not only reduce operator fatigue, but also minimize system fatigue, downtime and soil compaction

FAST FACTS

- Speeds up to 25 mph*.
- Narrow transport width.
- Evenly distributed combine load.
- Minimal maintenance.

VIBRATION AND SHOCK REDUCTION

- Smooth, comfortable ride.
- Reduced operator fatigue.
- Lower repair costs.

TECHNICAL

- All wheels have shock isolation.
- Bogie wheels have roll compliance:
 - Provides additional shock absorption
 - Even load on belt during transport reduces heat buildup and traction lug wear
- Even load distribution among all wheels does not change with adjustments in vertical weight:
 - All wheels remain in contact with the ground, regardless of ground contour
 - Belt remains in line as it is held to the ground, resulting in minimal drive lug wear



PRODUCTIVITY IMPROVEMENT

- Increased harvest and transport speeds:
 - No need to slow down for ditches and washouts
 - Move at higher speeds in and around fields
- Improved harvest performance:
 - Minimal header bounce
 - High flotation over wet fields
 - Reduced compaction with larger footprint
 - Improved harvest quality with less grain shift
- Full transport speed:
 - No transport limited with folding head installed
 - No “tire hop” at full road speed
- Minimal maintenance:
 - No grease fittings
 - Visible wheel bearing oil bath level
 - Reduced debris buildup with open design
 - Belt remains in line, resulting in minimal drive lug wear
 - Reduced heat buildup and traction lug wear

SPECIFICATIONS

Track Module Capacity	42,000 lb. (19090 kg)
Track Module Weight	7,700 lb. (3500 kg)
Track Module Height	80 in. (2032 mm)
Track Module Length	110 in. (2794 mm)
Belt Width	36 in. (914 mm)
Belt Length	282 in. (7163 mm)
Ground Contact Width	36 in. (914 mm)
Ground Contact Area:	
Flat Plate	2,743 sq. in. (1.77 sq. m)
Top of Carcass	3,474 sq. in. (2.24 sq. m)
Travel Speed	Up to 25 mph (40 kph)

AVAILABLE TRACK VERSIONS

To help widen your harvest window, the front axle of the 250 series combines can be equipped with the rugged, **triangular Quadtrac® track system for greater flotation and less soil compaction**. The Quadtrac design uses two 30- or 36-inch-wide rubber tracks to reduce ground pressure by 50% to 60%. This results in minimal soil disturbance, a smooth and comfortable ride and less stress on your fields.

Axial-Flow combines now have the option for factory installed PowerFlex Trax™. The PowerFlex Trax system is fully suspended and delivers enhanced operator comfort as they float over fields on long harvest days. The tracks provide high flotation in wet fields, help reduce compaction with a larger footprint and require minimal maintenance. And, they have a maximum transport speed of 25 mph. Ask your Case IH dealer about track options and which solution is best for your operation.



8250 GROUND PRESSURE COMPARISON (2022 COMBINE MODEL)

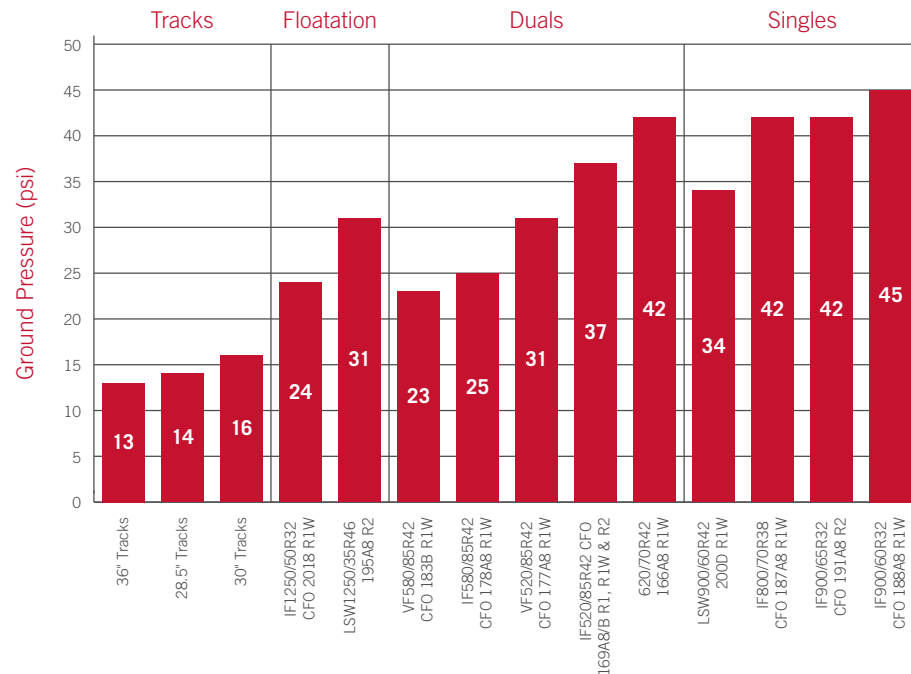

DIMENSIONS/TIRES/TRACKS

Axial-Flow combines are offered with a wide variety of tire and track options to meet the demands of North American producers, providing unmatched traction and flotation. Dimensions can vary depending on machine options, tire size, tire brand and tire pressure. If exact dimensions are required, measure the individual machine to validate those dimensions. Note: On 250 series combines with the folding auger option, the top of the auger becomes the highest point on the combine when left in the rigid position and the grain tank extensions are folded for transport.

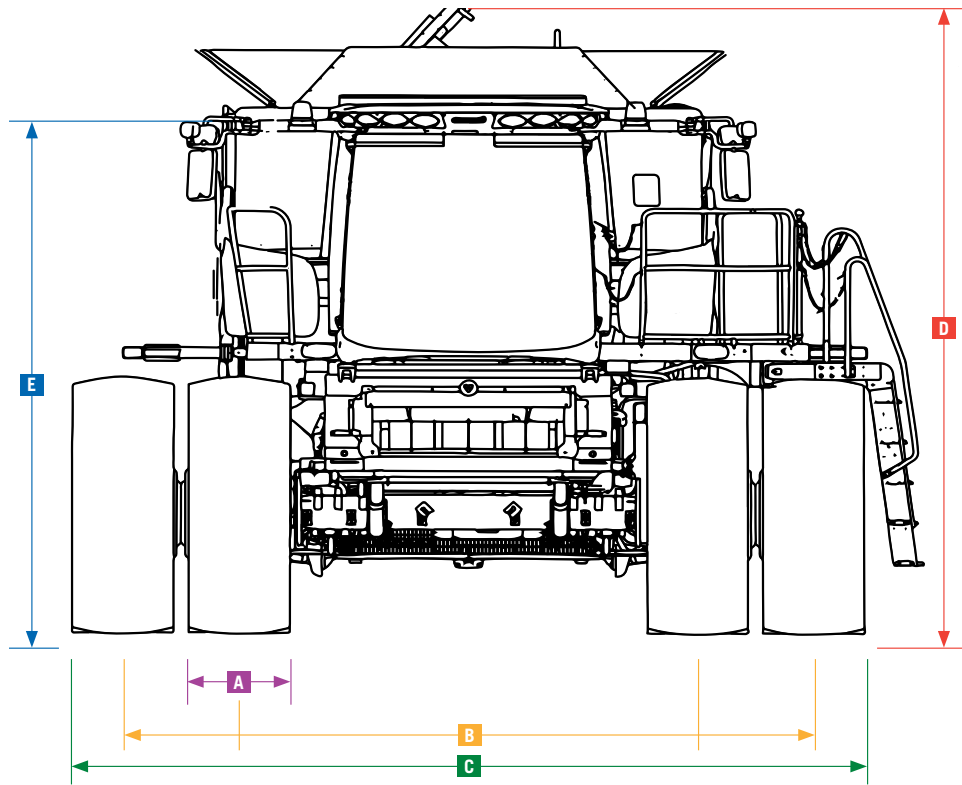

150 SERIES DIMENSIONS

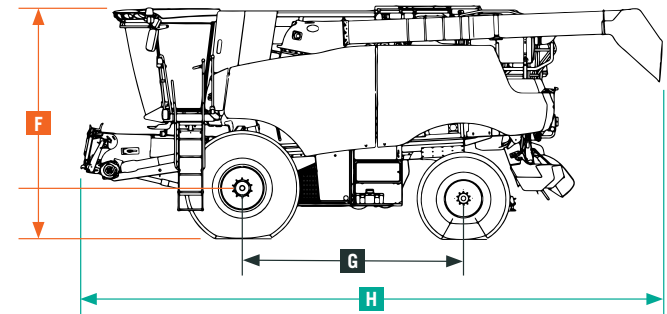

250 SERIES OVERALL LENGTH

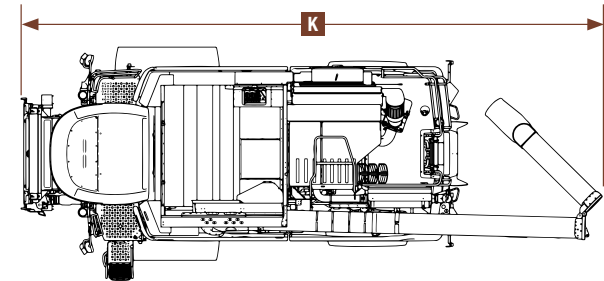

250 SERIES DIMENSIONS

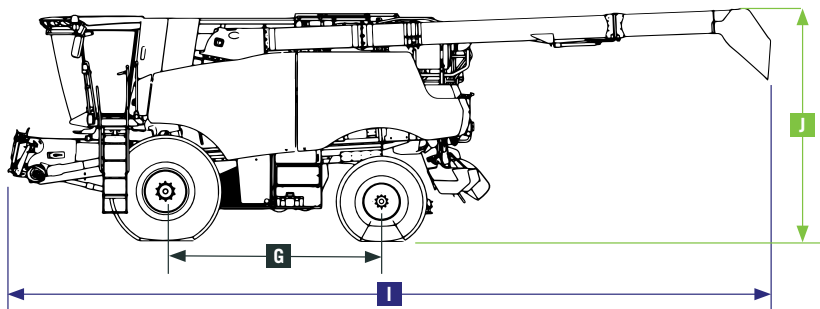

250 SERIES OVERALL LENGTH (auger folded)

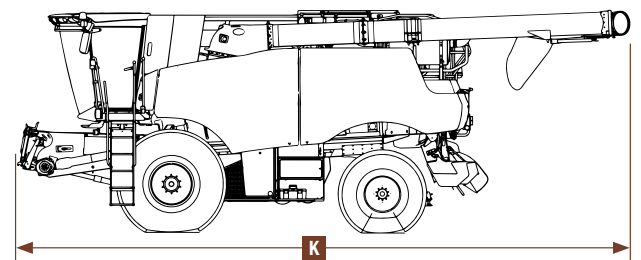

Drive Tires	Dished In or Dished Out	(A) Tire/Track Width	(B) Center/Center Tread Width	(C) Overall Width 150 Series	(C) Overall Width 250 Series	(D) Harvest Height 150 Series	(D) Harvest Height 250 Series	(E) Transport Height* 150 Series	(E) Transport Height 250 Series
Singles									
30.5L-32, LI 170 R1 (For 5150 only)	Dished In	33.1 in.	119.8 in.	152.9 in.	N/A	187.5 in.	N/A	150 in.	N/A
	Dished Out		134.4 in.	167.5 in.		187.5 in.		150 in.	
	Axle Ext Dished In		142.3 in.	175.3 in.		187.5 in.		150 in.	
800/65R32 172A8 (R1W)	Dished In	33.1 in.	119.8 in.	152.9 in.	N/A	188 in.	N/A	150.5 in.	N/A
	Dished Out		134.4 in.	167.5 in.		188 in.		150.5 in.	
	Axle Ext Dished In		142.3 in.	175.3 in.		188 in.		150.5 in.	
IF800/70R38 R1W	Dished In	33.1 in.	119.8 in.	N/A	N/A	N/A	N/A	N/A	N/A
	Dished Out		134.4 in.	167.5 in.		191 in.		153 in.	
	Axle Ext Dished In		142.3 in.	175.3 in.		191 in.		153 in.	
IF800/70R38 187 R1W TR Available in Transport Width: 14 ft. (168 in.)	Dished In	33.6 in.	120 in.	N/A	153.8 in.	N/A	187 in.	N/A	157.5 in.
	Dished Out		136.9 in.	N/A	170.7 in.	187 in.	157.5 in.		
	Axle Ext Dished In		144.9 in.	N/A	178.7 in.	187 in.	157.5 in.		
IF800/70R38 CFO 190A8 R1W	Dished In	33.6 in.	120 in.	N/A	153.8 in.	N/A	187 in.	N/A	157.5 in.
	Dished Out		136.9 in.	N/A	170.7 in.	187 in.	157.5 in.		
	Axle Ext Dished In		144.9 in.	N/A	178.7 in.	187 in.	157.5 in.		
900/60R32 176A8 (R1) (R1W)	Dished In	37.7 in.	119.8 in.	N/A	N/A	189 in.	N/A	151 in.	N/A
	Dished Out		134.4 in.	172.1 in.	189 in.	151 in.			
	Axle Ext Dished In		142.3 in.	179.9 in.	189 in.	151 in.			
IF900/60R32 CFO 188A8 R1W	Dished In	37.8 in.	120 in.	N/A	157.8 in.	N/A	188 in.	N/A	158.5 in.
	Dished Out		136.9 in.	N/A	174.7 in.	188 in.	158.5 in.		
	Axle Ext Dished In		144.9 in.	N/A	182.7 in.	188 in.	158.5 in.		
IF900/65R32 CFO 191A8 R2	Dished In	37 in.	120 in.	N/A	157 in.	N/A	189 in.	N/A	160 in.
	Dished Out		136.9 in.	N/A	174 in.	189 in.	160 in.		
	Axle Ext Dished In		144.9 in.	N/A	181.9 in.	189 in.	160 in.		
LSW900/60R42 CFO 200D R1W	Dished Out	36.9 in.	136.9 in.	N/A	173.9 in.	N/A	188 in.	N/A	158.5 in.
	Axle Ext Dished In		144.9 in.	N/A	181.8 in.	188 in.	158.5 in.		
Floaters									
IF1250/50R32 CFO 201B R1W	Axle Ext Dished In	53 in.	144.9 in.	N/A	197.9 in.	N/A	186 in.	N/A	155 in.
LSW1250/35R46 195B R2	Axle Ext Dished In	49.4 in.	144.9 in.	N/A	194.3 in.	N/A	188 in.	N/A	158 in.
Duals									
520/85 R42 (R1) (R1W)	Inner (30)	23.3 in.	120 in.	143.5 in.	N/A	188 in.	N/A	150.5 in.	N/A
	Outer (30)		180 in.	203.5 in.					
VF520/85R42 CFO 177A8 R1W	Inner (30)	21.4 in.	120 in.	N/A	141.4 in.	N/A	188.7 in.	N/A	159.5
	Outer (30)		180 in.	N/A	201.4 in.				
520/85 R42 157A8 (R2)	Inner (30)	21.7 in.	120 in.	141.9 in.	N/A	N/A	N/A	N/A	N/A
	Outer (30)		180 in.	201.9 in.					
IF520/85R42 CFO 169A8/B R2	Inner (30)	22.4 in.	120 in.	N/A	142.4 in.	N/A	190.2 in.	N/A	161 in.
	Outer (30)		180 in.	N/A	202.4 in.				
620/70R42 160A8 & 166A8 (R1W)	Inner (30)	26.6 in.	120 in.	146 in.	146.6 in.	191 in.	189.2 in.	152 in.	160 in.
	Outer (30)		180 in.	206 in.	206.6 in.				
VF580/85R42 CFO 183A8 R1W	Inner (30)	23.6 in.	120 in.	N/A	143.6 in.	N/A	191.9 in.	N/A	162.7 in.
	Outer (30)		180 in.	N/A	203.6 in.				
Tracks									
	N/A	30 in.	153.5 in.	N/A	183.5 in.	N/A	191 in.	N/A	170 in.
		36 in.			189.5 in.				

Axial-Flow Series Dimensions	(D) Vehicle Height Field	(F) Vehicle Height Transport	(G) Wheelbase	(H) Vehicle Length Feeder to Unloading Spout	(I) Vehicle Length Feeder to Unloading Spout	(J) Vehicle Height At Spout - Auger Fully Extended	(K) Vehicle Length Feeder to Unloading Auger Folded
150 Series							
With Base Unloader Tube	187 – 197 in.	154 – 160 in.	150 in.	346 in.	–	–	–
Base Tube With 36-in. Ext.	187 – 197 in.	154 – 160 in.	150 in.	382 in.	–	–	–
Base Tube With 52-in. Ext.	187 – 197 in.	154 – 160 in.	150 in.	398 in.	–	–	–
250 Series							
23.5-ft. Unloading Auger	187 – 197 in.	154 – 160 in.	148 in.	–	389 in.	157 in.	–
28.9-ft. Unloading Auger	187 – 197 in.	154 – 160 in.	148 in.	–	456 in.	161 in.	–
28.9-ft. Folding Auger	187 – 197 in.	154 – 160 in.	148 in.	–	456 in.	161 in.	368 in.
34-ft. Folding Auger	187 – 197 in.	154 – 160 in.	148 in.	–	522 in.	164 in.	430 in.

150 SERIES SPECIFICATIONS	AXIAL-FLOW 6150	AXIAL-FLOW 7150
Combine Class Size	Class 6	Class 7
ENGINE		
Type - Tier 4 B/Final	Case IH - FPT	
Displacement	8.7 L (531 cu. in.)	
Horsepower (Rated/Maximum)	348 hp (260 kW) / 411 hp (306 kW)	375 hp (280 kW) / 442 hp (330 kW)
Power Rise	63 hp (47 kW)	67 hp (50 kW)
Unload Boost - Power on Demand	34 hp (25 kW)	
Fuel Tank/DEF Tank Capacity	250 gal. (945 L) / 43 gal. (166 L)	
FEEDER		
Feeder Width	45.5 in. (1156 mm)	
Feeder Length w/o Rock Trap	45 in. (1143 mm)	
Feeder Drive Type	Belt	
Reverser System	Hydraulic	
Head Lift Cylinders Standard/Optional	3.15 in. (80 mm) / 3.35 in. (85 mm)	
Lateral Tilt Range Optional	+/- 5 degrees	
Stone Trap (Opt)	Beater/Sump	
THRESHING/SEPARATING		
Threshing Type	Rotary	
Rotor Drive Type/Rotor Diameter	Belt Drive / 30 in. (762 mm)	
Rotor Speeds	250 - 1150 rpm	
# of Concave/Modules	6	
Threshing/Separating Area Wrap	156.5° / 133°	
Separating Grates/Modules	3	
Discharge Beater Standard/Optional	Integral chopper/beater and chopper options available	
Auger Bed	Yes	
Active Grain Pan	No	
Grain Loss Monitor	Standard Equipment	
CLEANING SYSTEM		
Cleaning System Width	58 in. (1473 mm) fixed cleaning system / 56 in. (1422 mm) Cross Flow cleaning system	
Total Sieve Area	8,556 sq. in. (5.52 m ²) fixed cleaning system / 8,370 sq. in. (5.40 m ²) Cross Flow cleaning system	
Fixed or Self-leveling Cleaning System	Fixed or Cross Flow	
Cleaning Capability % Slope (Degrees)	N/A fixed / 12° Cross Flow	
Sieve Louver Adjustment (In-cab/Manual)	Standard/N/A	
Cleaning Fan Type/Drive	Cross-Flow fan/Belt Variator	
Fan Speed Range	450 - 1,300 rpm	
Fan Diameter	11.4 in. (290 mm)	
CONVEYING AND STORAGE		
Tailings Elevator	Tailings return to rotor	
Clean Grain Elevator (Dimensions/Capacity)	9 × 15.9 in. (229 × 404 mm) / 5,000 bu./hr.	
Grain Tank Capacity	300 bu. (10 570 L)	
Unloading Auger Length	25.8 ft. (7.86 m)	
Unloading Rate	3.2 bu. (113 L) per second	
DIMENSIONS		
Wheel Base - 2WD Axle / Pra Opt.	150.2 in. (3 815 mm) / 150.2 in. (3 815 mm) - PGA	
Width (Overall Single Tires 120-in. Tread)	150.9 in. (3 833 mm)	
Minimum Weight (2WD and Single Drive Tires)	34,130 lb. (15 481 kg)	34,850 lb. (15 808 kg)
Typical Weight (2WD and Dual Drive Tires)	37,130 lb. (16 842 kg)	37,850 lb. (17 168 kg)
Cab Height	153.8 in. (3 907 mm)	

250 SERIES SPECIFICATIONS	AXIAL-FLOW 7250	AXIAL-FLOW 8250	AXIAL-FLOW 9250
Combine Class Size	Class 7	Class 8	Class 9
ENGINE			
Type - Tier 4 B/Final	Case IH - FPT		
Displacement	11.1 L (677 cu. in.)	12.9 L (787 cu. in.)	16.0 L (970 cu. in.)
Horsepower (Rated/Maximum)	402 hp (299 kW)/468 hp (349 kW)	480 hp (358 kW)/555 hp (414 kW)	550 hp (410 kW)/625 hp (466 kW)
Power Rise	66 hp (49 kW)		75 hp (56 kW)
Unload Boost - Power on Demand	66 hp (49 kW)		75 hp (56 kW)
Fuel Tank/DEF Tank Capacity	297 gal. (1124 L)/43 gal. (166 L)		317 gal. (1200 L)/43 gal. (166 L)
FEEDER			
Feeder Width	54 in. (1372 mm)		
Feeder Length w/o Rock Trap	94 in. (2388 mm)		
Feeder Drive Type	CVT drive		
Reverser System	CVT hydraulic		
Head Lift Cylinders	2.95 in. (75 mm)/3.5 in. (90 mm)/3.7 in. (95 mm)		
Lateral Tilt Range Optional	+/- 5 degrees		
Fore/Aft Faceplate Tilt Optional	12 degrees		
Stone Trap (Opt)	Spiral Beater/Sump		
THRESHING/SEPARATING			
Threshing Type	Rotary		
Rotor Drive Type/Rotor Diameter	CVT Drive/30 in. (762 mm)		
Rotor Speeds	220–1180 rpm		
Number of Concave/Modules	2 pair		
Threshing/Separating Area Wrap	180°/180°		
Separating Grates/Modules	2 pair		
Discharge Beater Standard/Optional	Integral chopper/beater and chopper options available		
Auger Bed	No		
Active Grain Pan	Yes		
Grain Loss Monitor	Standard equipment		
Cage Vanes Standard/Optional	Manual adjust with turn buckle / In-cab adjustable		
CLEANING SYSTEM			
Cleaning System Width	62 in. (1575 mm)		
Total Sieve Area	10,075 sq. in. (6.9 m ²)		
Fixed or Self-leveling Cleaning System	Self-leveling		
Cleaning Capability % Slope (Degrees)	12.1% (7.0°)		
Sieve Louver Adjustment (In-cab/Manual)	Standard/N/A		
Cleaning Fan Type/Drive	Cross-Flow fan/hydraulic		
Fan Speed Range	300–1150 rpm		
Fan Diameter	15.4 in. (391 mm)		
CONVEYING AND STORAGE			
Tailings Elevator	Tri sweep crop processor		
Clean Grain Elevator (Dimensions/Capacity)	11.9×10.4 in. (302×264 mm)/6,500 bu/hr.		
Grain Tank Capacity Standard/Optional	315 bu. (11100 L) /410 bu. (14448L)	410 bu. (14448 L)	
Unloading Auger Length	28 ft. 9 in. (8.8 m)		
Unloading Rate	4.0 bu. (141 L) per second	4.5 bu. (159 L) per second	
DIMENSIONS			
Wheel Base - 2WD Axle / Pra Opt.	147.7 in. (3752 mm)/148.5 in. (3772 mm) - PGA		
Width (Overall Single Tires 120-in. Tread)	152 in. (3861 mm)	156 in. (3962 mm)	
Minimum Weight (2WD and Single Drive Tires)	42,245 lb. (19162 kg)	42,845 lb. (19434 kg)	43,790 lb. (19863 kg)
Typical Weight (2WD and Dual Drive Tires)	46,378 lb. (21037 kg)	46,979 lb. (21309 kg)	47,924 lb. (21738 kg)
Cab Height	153.5 in. (3899 mm)	153.7 in. (3904 mm)	
TECHNOLOGY			
AFS Connect Advanced With 2 Way File Transfer Combine Automation Standard/Optional	No automation / AFS Harvest Command		



caseih.com

SAFETY NEVER HURTS!™ Always read the Operators Manual before operating any equipment. Inspect equipment before using it, and be sure it is operating properly. Follow the product safety signs, and use any safety features provided. CNH Industrial America LLC reserves the right to make improvements in design and changes in specifications at any time without notice and without incurring any obligation to install them on units previously sold. Specifications, descriptions and illustrative material herein are as accurate as known at time of publication, but are subject to change without notice. Availability of some models and equipment builds varies according to the country in which the equipment is used.

©2022 CNH Industrial America LLC. All rights reserved. Case IH is a trademark registered in the United States and many other countries, owned by or licensed to CNH Industrial N.V., its subsidiaries or affiliates. Any trademarks referred to herein, in association with goods and/or services of companies other than CNH Industrial America LLC, are the property of those respective companies. Printed in U.S.A. www.caseih.com CIH22041802

CASE IH