

**HYDRAULIC ROCK BREAKER
CB62**

570T, 570ST, B80B, 770, 770EX, 770EX MAG., 851EX

CASE

CONSTRUCTION



**BREAKTHROUGH ANY
OBSTACLE WITH ROCK
BREAKER ATTACHMENT**

CaseCE.com
EXPERTS FOR THE REAL WORLD
SINCE 1842

Attachments.
BUSINESS SOLUTIONS

CASE
CONSTRUCTION

ROCK BREAKER CB62

INTRODUCTION

CASE Genuine Parts product range offers strong, reliable & productive hydraulic Rock Breaker for Loader Backhoes with a complete range of hammer tools for all the applications.

This offers customers the freedom to choose the best tool combination, according to machine requirement, which ensures maximum productivity.



To meet our mission of extending full product/parts support to our dealers and customers with a comprehensive solution for their requirements, CASE has launched its Rock Breaker. CASE Rock Breaker mounting accessories, brackets and hose kits are CASE engineered and designed, for maximum efficiency in all its applications. This also includes pin and bushing kits, hose kits and mounting brackets for all CASE machines.

CASE Rock Breaker are supported throughout India with spare parts, manuals and technical support at all times to minimize downtime and maintain application demand. CASE Rock Breaker installations are taken care by CASE After-Sales Support Team throughout India, and integrate the dealer and customer with its Attachment Product Training to sync into the CASE system.



FEATURES

- **Technology gives consistent performance on every blow**
- **Easy service and maintenance**
- **Low fatigue on base machines**
- **High Returns on investments**
- **Low running cost**
- **Ensured reliability**
- **Quality verified & approved by CASE engineering team**
- **CASE Rock Breaker with across the nation warranty**
- **High impact energy & Impact rate**

TYPE



- **CASE Rock Breaker provides optimized rotation angles & allows a wide range of work positions.**
- **Fully enclosed power cell for maximum component protection from work materials**
- **Sound absorbing elements inside housing, lower noise output for sound sensitive applications**

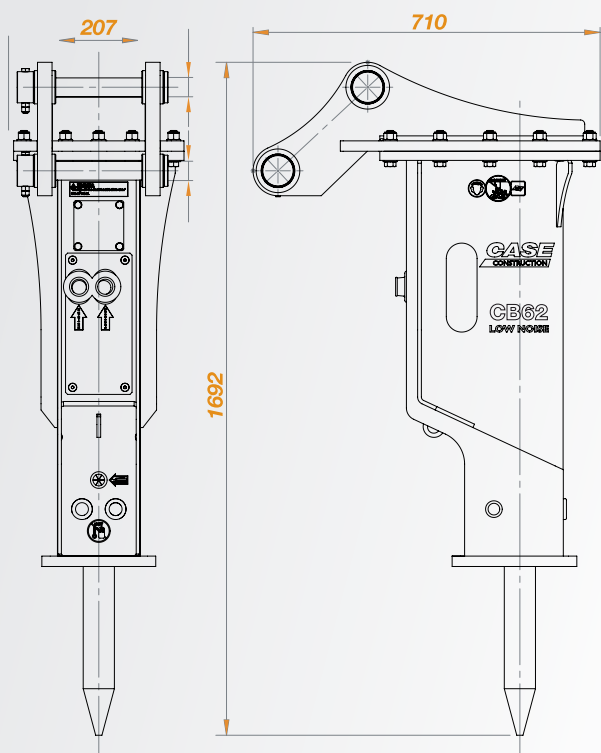

ROCK BREAKER CB62

TECHNICAL SPECIFICATIONS

Rock breaker type	Hybrid, top mounting, closed box type
Operating weight*	426 kg
Impact rate	380-900 bpm
Operating pressure	120-165 kg/cm ²
Port relief setting pressure**	175 kg/cm ²
Oil flow range	34-68 lpm
Tool diameter	75 mm
Carrier weight	4.5 - 8.0 Ton



Conventional tool	Application type				
	Primary breaking	Secondary breaking	Hard rock removal	Soft material & rock removal	Demolition
 Moil	●		●	●	●
 Chisel	○		○	●	●
 Blunt		●			○

Special tool	Application type		
	Asphalt removal	Compacting	Post driving
 Spade	●		
 Compacting		●	
 Elephant foot			●

Note:

* Operating weight includes breaker bracket with 2 pins, one work tool and two hydraulic hoses

** Guide for carrier port relief valve pressure setting

SMART DESIGN

HOUSING & POWER CELL

- Power cell floating system
- No metal to metal contact, bolt free
- Fully enclosed power cell

NOISE PROTECTOR

- Less noise (silenced type)

INTERNAL VALVE SYSTEM

- Energy efficient internal control valve system

RETURN LINE BACK PRESSURE

- Allowable up to 44 bar (highest in the industry)

LARGE CAPACITY ACCUMULATOR & DIAPHRAGM

- Protect carrier hydraulic components from peak pressure
- Accelerate striking speed
- Prevent cavitation and increase seal life time
- Extended diaphragm service life

BOTTOM PLATE (HARDOX/AR400)

- Protect housing structure
- Increase housing service life

TOOL

- Heat treated tool
- Longer wear life

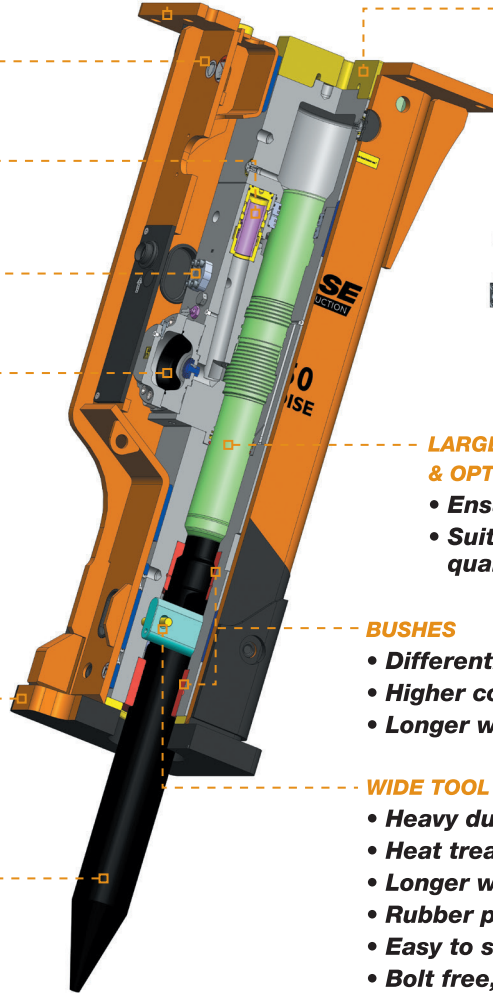

CUSHION DAMPER

- Absorb repercussion from hammering and increases carrier endurance

AUTO LUBRICATION SYSTEM

- Increase tool, tool pins, bush life time
- Vibrating type

LARGER GAS CHAMBER & OPTIMUM PISTON SIZE

- Ensure higher impact power and speed
- Suitable for secondary rock breaking quarry application

BUSHES

- Differentiated heat treatment
- Higher core hardness
- Longer wear life

WIDE TOOL PIN

- Heavy duty oval shape dual pins
- Heat treated pins
- Longer wear life
- Rubber plugged on all mounting holes
- Easy to service
- Bolt free, low maintenance cost

Corporate Identity Number: U29240MH1998PTC117183
CASE NEW HOLLAND CONSTRUCTION EQUIPMENT (INDIA) PRIVATE LIMITED
 B1-207, 2nd Floor, Boomerang, Chandivali Farm Road
 Near Chandivali Studio, Andheri (East)
 Mumbai - 400072, Maharashtra, India
 Email: caseindia@cnhind.com

NOTE: CASE provides specific outfits for various countries and many optional fittings (OPT). The illustrations on this or other leaflets may relate to standard or optional fittings. Please consult your CASE dealer for any information in this regard and any possible updating on components. CNH Industrial reserves the right to modify machine specifications without incurring any obligation relating to such changes.



CASE Customer Assistance
1800 4199 770