

V110D - VIBRATORY SOIL COMPACTOR



**POWER THAT
SHAPES THE GROUND**



DISCOVER THE COMPACTOR FEATURES.

MEET YOUR CHALLENGES HEAD-ON

Every jobsite demands resilience: uneven terrain, tight deadlines, unpredictable conditions. To stay productive, you need a machine that delivers consistent performance day after day. The New Holland VI10D soil compactor is engineered to help you meet those challenges head-on, combining power, efficiency and long-term reliability.

ENGINE & POWERTRAIN

- Turbocharged & after-cooled for efficient combustion
- High-mounted pre-cleaner for dusty environments
- Smooth hydrostatic drive with variable speed control

SERVICEABILITY

- Grouped daily service points
- Easy access to battery, filters and pumps
- Fast maintenance for reduced downtime





OPERATOR STATION

- Wide steps and strong grab handles
- Foldable canopy legs for easier transport
- Rubber-mounted operator platform
- Optional enclosed cab with A/C

VISIBILITY & CONTROLS

- Clear forward view to the drum
- Backlit gauges with key alerts
- Ergonomic control layout

VIBRATION & COMPACTION

- Variable-displacement pump for stable vibration output
- Optional high-torque drum drive for slopes
- Smooth drum or padfoot shell options
- Durable 25 or 32 mm drum shell

CHASSIS & STRUCTURE

- Reinforced drum support frame
- Rubber isolation mounts reduce vibration transfer
- $\pm 15^\circ$ drum oscillation and 37° steering angle

SOLID PERFORMANCE. UNMATCHED RELIABILITY.

ENGINE & POWERTRAIN

Reliable Power for Every Terrain

At the heart of the VI 10D is the FPT S8000 Tier III engine, delivering high torque and dependable performance in all soil conditions. Its turbocharged and after-cooled design ensures dense intake air, efficient combustion and reduced fuel consumption. A high-mounted pre-cleaner protects the engine in dusty environments, extending component life. The hydrostatic drive system provides smooth, infinitely variable speed control, allowing the operator to match machine pace precisely to compaction needs.



FPT S8000: proven technology!

CHASSIS & STRUCTURE

Built Strong to Last Longer

The VI 10D is built around a heavy-duty 4-pin articulation joint designed to withstand severe working conditions. Its reinforced drum support frame absorbs high vibration loads without compromising structural integrity. Rubber isolation mounts reduce vibration transfer to the machine and operator platform, protecting components and improving comfort. With $\pm 15^\circ$ drum oscillation and a 37° steering angle, the VI 10D delivers excellent maneuverability even in confined areas.



VIBRATION & COMPACTION

Faster Density, Consistent Results

The dual-stage vibration system adapts easily to different soil types, ensuring uniform compaction across the entire working width. A variable-displacement pump maintains stable vibration output, while the optional high-torque drum drive boosts traction on slopes and challenging terrain. Choose between a smooth drum for granular materials or a clamp-on padfoot shell for cohesive soils. The 32 mm drum shell ensures long-term durability and consistent performance.



VISIBILITY & CONTROLS

Clear Views, Confident Operation

The V110D offers excellent visibility thanks to its sloped engine hood and elevated operator position. Forward visibility to the drum is unobstructed, supporting precise compaction control. The instrument cluster features backlit gauges and clear alerts for key machine functions. Ergonomic control placement ensures intuitive operation and reduced fatigue throughout the workday.

OPERATOR STATION

Comfort That Keeps You Productive

The operator environment is designed for visibility, comfort and safety. A 90° rotating seat provides a clear view of both the front drum and rear wheel, improving pass accuracy and reducing fatigue. Wide steps and sturdy grab handles ensure safe access, while foldable canopy legs simplify transport. The operator platform is mounted on rubber dampers to minimise vibration exposure. For maximum comfort in all weather conditions, an enclosed cab with air-conditioning is available.

SERVICEABILITY

Easy Access, Less Downtime

Daily maintenance is fast and efficient. A one-piece tilting hood provides ground-level access to the battery, filters and service points. Key components are grouped for quick checks, and the engine layout is optimised for easy access to hydraulic and hydrostatic pumps. These features reduce downtime and simplify routine service, helping operators stay productive and lowering total operating costs.



VI10D

ENGINE		
Make		FPT
Model		S8000 - TIER III
Type		turbocharged & aftercooled
Cylinders		4
Bore/stroke		104 x 115
Displacement	l	3.9
Fuel injection		Direct
Fuel		High speed diesel
Fuel filter		Spin-on type
Air intake		Turbocharged with internal EGR
Air filter		Replaceable dry type with dual element & coupled with turbo pre-cleaner
Engine oil filter		Spin-on type
Cooling		Liquid
Engine speeds (no load)		
- Low:	rpm	950±50
- High:	rpm	2150±25
Horsepower @ 2300 rpm		
Gross power (ISO 14396)	kW	82
Imperial	hp	110
Metric	hp	112
Max. torque (ISO14396)	Nm@1400	430
VIBRATION SYSTEM		
Type		Variable displacement bi-directional axial piston pump with manual displacement control
Drive to vibration pump		Mechanical
Engine to pump ratio		Direct Drive 1:1
Vibration motor		Fixed displacement mounted on drum
STEERING		
Steering system		Hydraulic assisted articulated
Steering angle	°	37 on either side (74 between stop to stop)
Turning radius (inner radius)	m	3,42
Drum oscillation angle	°	15
Tyre size		23.1/26
ELECTRICAL SYSTEM		
Alternator output (with/without cab)		105 A/65 A
Battery		Exide, 12V/ 130Ah
ELECTRICAL SYSTEM		
Fuel tank	l	235
Hydraulic tank	l	70
Engine crank case	l	9.1
Engine coolant	l	15
PROPULSION		
Type		Infinitely variable hydrostatic drive with variable displacement pump
Drive pump		Mechanical
Engine to pump ratio		Direct drive 1:1
Type		Variable displacement bi-directional axial piston pump with manual displacement control
Displacement	cc/Rev	78
Flow @2200 RPM	l	171
Charge pressure	bar	22@1800rpm
Drive motors		
Type		High speed low torque, bentaxis, axial piston dual displacement motor connected to rear axle
Drum drive		Radial piston motor, fixed displacement mounted on drum
Hydraulic oil filter		Cartridge
Axle		Heavy duty with integrated parking brake mechanism and integrated differential unit along with out board planetary geared wheel hub
Parking brake		Spring applied hydraulically released
Engagement		Operate on /off parking brake switch on instrument panel, engine stop
Machine speed:		
- Working speed	km/h	0-5.5
- Travel speed	km/h	0-11.5
Gradeability:		
With drum drive	%	36
Intermittent	%	40
INSTRUMENTATION		
Gauges (Backlit with illuminated pointers)		
- Engine Coolant Temperature		
- Fuel level		
- Engine RPM		
Indicators (Buzzer & Visual)		

COMPONENTS	ALARM TYPE	
	BUZZER	VISUAL
Battery not charging	NO	YES
Turn Signal Left & Right	YES	YES
Two Speed travel Mode	NO	YES
Cold Start/Pre-heater	YES	YES
Neutral	NO	YES
Position Lamp	NO	YES
High Beam	NO	YES
Low Beam	NO	YES
Parking Brake Engagement	NO	YES
Engine Coolant Overheat	YES	YES
Low Lube oil Pressure	YES	YES
Hydraulic oil Filter Clog	YES	YES
Air Filter Clog	YES	YES

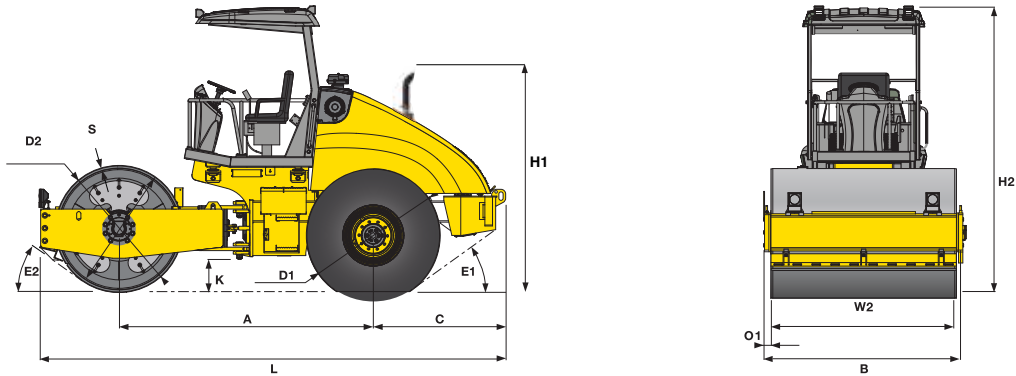

DIMENSIONS				V110D
A	Wheelbase	mm		3003
B	Overall width of the machine	mm		2324
C	Rear overhang	mm		1560
D1	Diametre of the rear tyres	mm		1560
D2	Diametre of the drum	mm		1500
H1	Height of silencer from ground level	mm		2561
H2	Overall height of the machine (with/without cab)	mm		3389/3373
K	Ground clearance	mm		382
L	Overall length of the machine	mm		5508
O1	Side overhang	mm		87
S	Drum shell thickness	mm		25 or 32
W2	Overall width of the drum	mm		2150
E1	Rear departure angle	mm		36
E2	Front departure angle	mm		32

Dimension may vary within $\pm 5\%$

OPERATING DATA		V110D-D				V110D-PD			
		NON ROPS Canopy	ROPS CAB	NON ROPS Canopy	ROPS CAB	NON ROPS Canopy (3shell 12thk)	ROPS CAB (3shell 12thk)	NON ROPS Canopy (3shell 6thk)	ROPS CAB (3shell 6thk)
Drum thickness		25 mm		32 mm		25 mm		32 mm	
Operating weight with operator	Kg	10630	10910	11100	11380	12399	12679	12390	12670
Front axle load	Kg	6000	6090	6470	6560	7769	7850	7760	7859
Rear axle load	Kg	4630	4820	4630	4820	4630	4820	4630	4820
Static linear load front	Kg/CM	28	28	30	30	-	-	-	-
Frequency (1st Vib. Stage)	Hz	31	31	31	31	31	31	-	-
Frequency (2nd Vib. Stage)	Hz	34	34	34	34	34	34	34	34
Amplitude LF-HF	mm	2.0-0.9	2.0-0.9	1.8-0.8	1.8-0.8	1.3-0.6	1.3-0.6	1.3-0.6	1.3-0.6
Centrifugal force (1st Vib. Stage)	Kg	26815	26815	26815	26815	26815	26815	-	-
Centrifugal force (2nd Vib. Stage)	Kg	14826	14826	14826	14826	14826	14826	14826	14826
Max. applied force (1st Vib. Stage)	Kg	33285	33375	33285	33375	34584	34674	-	-
Max. applied force (2nd Vib. Stage)	Kg	21296	21386	21296	21386	22595	22685	22586	22776



The New Holland dealer network is, in itself, the best guarantee of continued productivity for the machines it delivers to its customers. New Holland service technicians are fully equipped to resolve all maintenance and repair issues, with each and every service point providing the high standards of New Holland's stringent quality guidelines.

The New Holland global parts network ensures fast, reliable, replacement parts for less downtime, increased productivity and, of course, profitable operation for its customers.

Learn more at www.newholland.com

Printed on recycled paper
CoC-FSC 000010 CQ Mixed sources



AT YOUR OWN DEALERSHIP

The information contained in this brochure is intended to be of general nature only. The NEW HOLLAND CONSTRUCTION MACHINERY S.p.A. company may at any time and from time to time, for technical or other necessary reasons, modify any of the details or specifications of the product described in this brochure. Illustrations do not necessarily show products in standard conditions. The dimensions, weights and capacities shown herein, as well as any conversion data used, are approximate only and are subject to variations within normal manufacturing techniques.