

PUMA

PUMA

TRACTORS 140 - 155 HP



CASE IH

CASE IH

MODELS	PUMA 140	PUMA 155
ENGINE		
Number of cylinders / type	6 / turbocharged and intercooled	
Capacity (litres)	6.7	6.7
Bore x stroke mm	104 X 132	104 X 132
Rated power ECE R120 ¹⁾ (kW/hp(CV))	104 / 142	116 / 158
Rated power ECE R120 ¹⁾ Power Management ²⁾ (kW/hp(CV))	123 / 167	135 / 183
Rated engine speed (rpm)	2200	2200
Maximum power ECE R120 ¹⁾ (kW/hp(CV))	112 / 150	124 / 166
Maximum power ECE R120 ¹⁾ Power Management ²⁾ (kW/hp(CV))	131 / 178	142 / 193
... at engine speed (rpm)	1900 - 2000	1900 - 2000
Maximum torque (Nm/rpm)	643 / 1400	690 / 1400
Maximum torque - Power Management ²⁾ (Nm/rpm)	678 / 1600	748 / 1600
Torque rise Standard / Power Management ²⁾ (%)	42 / 27	37 / 28
Fuel tank (litres)	285	285
TRANSMISSION		
18x6 Semi- / Full Powershift 40 kph	○ / ●	○ / ●
19x6 Semi- / Full Powershift Economy 40 kph @ reduced rpm	○ / ○	○ / ○
19x6 Semi- / Full Powershift 50 kph	○ / ○	○ / ○
Creeper	○	○
Rear axle diff-lock type	Multi disc wet plate with management system	
Service brake	Hydraulically operated multiple wet disc brake, self adjusting	
FOUR-WHEEL DRIVE AND STEERING		
Type	Electro-hydraulic with management system	
Front axle suspension	○	○
Steering angle (°)	55	55
Min. turning radius ³⁾ track setting 1829 mm (m)	5.45	5.45
POWER TAKE OFF		
Type	Electro-hydraulic with Auto PTO control available	
Speeds Standard / Option	540/540E/1000 / -	
Engine speeds Standard / Option (rpm)	1969/1546/2120 / -	
Shaft type	1 3/8" 21 splines / 1 3/8" 6 splines	
	○	○
HYDRAULIC SYSTEM		
Pump flow and system type main hydraulic Stand/Optional (l/min)	113 PFC	113 PFC
System pressure (bar)	210	210
Control type	EHC with ride control	
Max. lift capacity (kg) Standard/Optional	6689 / 8259	6689 / 8259
Max. number of remote valves Standard / Optional	3 or 4 mechanical or 3 electrical	3 or 4 mechanical or 3 or 4 electrical
Max. number of mid mount valves with electronic joystick	2 electric	2 electric
Category type	Cat II / III	Cat II / III

MODELS	PUMA 140	PUMA 155
WEIGHT		
Minimum weight (kg)	5450	5650
Permissible total weight (kg)	10500	10500
Max. permissible weight front (kg)	4900	4900
Max. permissible weight rear (kg)	7300	7300
DIMENSIONS³⁾		
A: Total length (mm)	4672	4672
B: Total height (mm)	2995	2995
C: Total width (across rear fenders with 150 mm extension) (mm)	2682	2682
D: Wheel base (mm) Standard/with front axle suspension	2734 / 2789	2734 / 2789
E: Height at centre of rear axle / highest point (mm)	2239	2239
F: Track setting front (mm)	1560 - 2256	1560 - 2256
rear (mm)	1470 - 2294	1470 - 2294
STANDARD TYRES⁴⁾		
Front	480/70R28	480/70R28
Rear	580/70R38	580/70R38

● Standard Equipment ● Optional Equipment - Not available

¹⁾ ECE R120 correspond to ISO 14396 and 97 / 68 / EC

²⁾ Power Management is only available during mobile PTO and haulage applications

³⁾ With standard tyres

⁴⁾ Other tyres on request

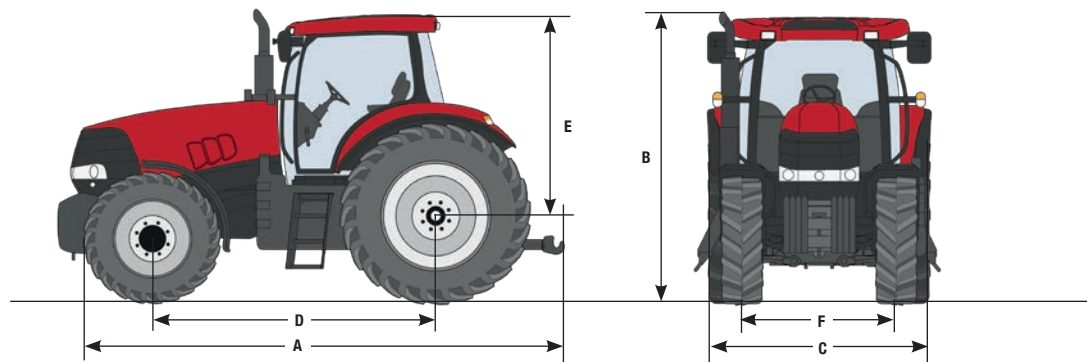



CNH Industrial, Middle East & Africa, Riva Paradiso, 14 - 6902 Paradiso-Lugano Switzerland

 Safety never hurts! Always read the Operator's Manual before working with any equipment. Inspect equipment before using it, and be sure it is operating properly. Follow the product safety signs, and use any safety features provided. This literature has been published for worldwide circulation. The standard and optional equipment and the availability of individual models may vary from one country to the next. Case IH reserves the right to undertake modifications without prior notice to the design and technical equipment at all times without this resulting in any obligation whatsoever to make such modifications to units already sold. Whilst every effort is made to ensure that the specifications, descriptions and illustrations in this brochure are correct at the time of going to press, these are also subject to change without prior notice. Illustrations may show optional equipment or may not show all standard equipment. Case IH recommends **ARCELA** lubricants. 24MEAPUMCOM002

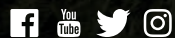

caseih.com

CASE IH