

AFTERSALES
PRODUCTS AND SERVICES

CASE
CONSTRUCTION

FAST, EFFICIENT & SAFE
WITH CASE



HOW CAN YOU BE FASTER, SAFER & MORE EFFICIENT? /

Optimizing performance and results requires concrete actions rather than vague promises. At CASE, this means prioritizing a 360° service offering based on high-quality parts and tailored support.

PARTS THAT PERFORM

To capitalize on your machinery, every CASE part is designed to exacting specifications, made from robust materials and tested to high standards. Our ranges are always expanding to better adapt to your jobsites and targets.

SERVICES THAT ADD VALUE

Drawing on dedicated teams, connected technologies and years of experience, CASE services seamlessly integrate into your daily life. So, you can be proactive in the way you manage your machinery and deal with any unexpected events.

For more productivity and peace of mind, every day.



CASE PARTS KEEPING YOUR MACHINERY PERFORMING AT ITS BEST /

We're constantly growing our parts offering with new product references and ranges, as well as high-precision machine control solutions, to meet your evolving needs. Whether your priority is price, sustainability or versatility, you have access to a wide range of parts built just for your Case machinery by our experts.

Lasting Quality / Maximum Uptime / Reliable Performance



Genuine Parts
HIGH PERFORMANCE

CASE
CONSTRUCTION

GENUINE PARTS MORE FROM YOUR MACHINES /

Purchasing machinery is a long-term investment. This is why it is so important to choose high-quality replacement parts that maintain your performance, day after day. All CASE parts have been designed by the same experts who made the originals with the same rigorous standards. So, you get more from your machines.

KNOW YOUR PARTS WILL LAST

Each CASE replacement part is **tested according to a wide range of stringent criteria**, the same we use for the original versions, to ensure maximum durability and safety. We believe in the quality of our parts, which is why you also get a **12-month warranty**, every time.

ADD VALUE TO YOUR MACHINE

Getting more from your machines also means regular maintenance from professionals who know each CASE model inside out. This not only **optimizes your performance** on a daily basis, but also **increases the residual value** of your machinery.

BENEFIT FROM CASE EXPERTISE

With years of experience looking after machinery like yours, CASE technicians are well placed to find the most efficient and appropriate solutions. So, you get back into action as quickly as possible.

GENUINE MAINTENANCE KIT DESIGNED TO MAXIMIZE YOUR EFFICIENCY

With a large range of **CASE service maintenance kits** for the most popular machines in the field

- + **Time and space savings**
All parts delivered together in one box
- + **Financial gain**
Reduce your TCO with preferential prices
- + **Enhanced efficiency**
Only one PN to identify and order



GET MORE FROM CASE



**ASK
TED!**

Join our expert TED in the workshop to benefit from:

- + **Specialist ADVICE**
- + **INFORMATION** about parts
- + **Maintenance TIPS**

Available on www.casece.com



AT EVERY STEP

Through our wide Service Network, CASE strives to support and guide you, from targeted special offers to specialist advice tailored to your needs.



REMAN

CHOOSING SUSTAINABLE QUALITY /

Reman • Parts
REMANUFACTURED

CASE
CONSTRUCTION

Committed to offering more choice and lowering your impact on the environment, we're constantly growing our line of remanufactured parts.

*Designed for CASE equipment of any age, the CASE REMAN range combines **quality, price and ecology** to ensure your machines are as efficient as brand-new units.*

3 GOOD REASONS TO OPT FOR REMAN

Using a rigorous disassembly, cleaning and re-engineering process, we have developed an ever-growing range REMAN parts for your every need.

THESE REMANUFACTURED PARTS ENABLE YOU TO:

1 MAKE SIGNIFICANT SAVINGS

REMAN parts **cost up to 50% less** than new ones and also reduce machine downtime as they can be fitted quickly as an alternative to complicated rebuilds.

2 ENJOY PEACE OF MIND

Each REMAN part is restored to the same stringent technical standards as Genuine parts. That's why you also get a **2-year warranty** on all Reman engines.

3 LIMIT YOUR ENVIRONMENTAL IMPACT

Based on a circular process, CASE REMAN parts help keep used components out of landfills, while also requiring **up to 80% less energy** to construct than new ones.



THE FLOW OF SUSTAINABILITY

Core reception



1- Disassembling and cleaning

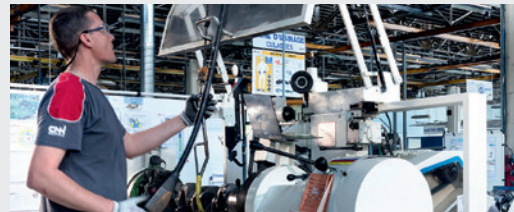

2- Industrial reconditioning



3- Assembly

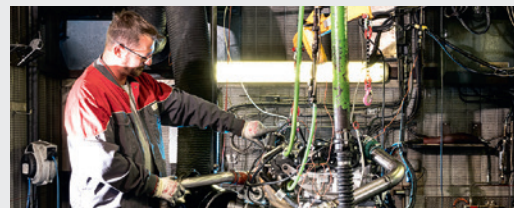

4- Testing

Finished remanufactured product

Ready for action,
just like new!



ALTERNATOR



TENSIONER

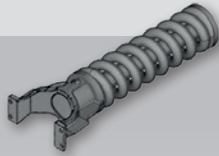

DRILLED SHOE



STARTER

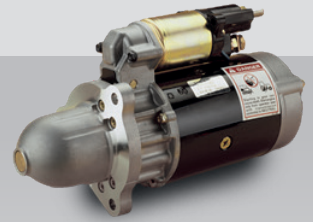

RUBBER TRACK



BOLT ON PAD

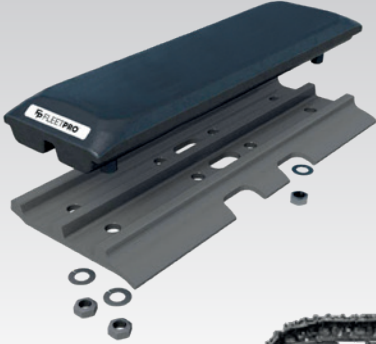

CHAIN ON PAD

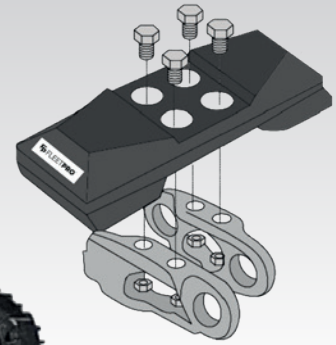

STEEL UNDERCARRIAGE

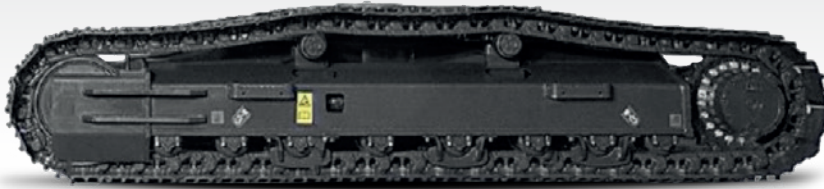

QUALITY & PERFORMANCE BEYOND WARRANTY /

It can be tempting to take short cuts with older machinery to reduce costs.

*To help you achieve high levels of performance while also managing your budget, we created FLEETPRO, a second-line range for older machines that are out of warranty. The ideal choice if you're looking to combine **quality and competitive pricing**.*

WHY CHOOSE FLEETPRO?

- + **Certified parts designed for tough conditions**
- + **Competitive prices and long-term savings**
- + **CASE expertise in our certified workshops**
- + **Compatible with all makes**





CASE SITECONTROL FASTER & MORE EFFICIENT/

Drawing on the latest technology, telecommunications and engineering, machine control helps you minimize rework by offering reliable, repeatable precision every time. Adapted to all kinds of earth-moving applications – CASE’s machine control solutions deliver faster, higher quality work.

FOR YOUR CONSTRUCTION SITE, THIS MEANS:

- 1 GRADING EFFICIENCY** Fewer passes, less wear, less fuel, reduced over and undercutting, constant results.
- 2 JOBSITE SAFETY** Less personnel required to check the grade means staff are less exposed to risks.
- 3 JOBSITE EFFICIENCY** Less stakes, less surveying needed during job, remotely modify job design or give assistance.
- 4 OPERATOR EFFICIENCY** More complex jobs for novice operators, less fatigue, more comfort & productivity.



ADD VALUE TO YOUR MACHINE

CASE Construction is expanding its offering to **Hemisphere GNSS** solutions, initially as a retrofit guidance system for excavators. Work is ongoing to expand the range to other product lines.

Also, by partnering with high-precision specialists **Leica Geosystems** and **Trimble**, CASE delivers the most flexible system on the market. Why not prepare your CASE machine with Hemisphere GNSS, Leica or Trimble predisposition and hire the 2D or 3D components you need when the job asks for it? Please refer to your local dealer for more information and options best fit for you.



Attachments.
BUSINESS SOLUTIONS

CASE
CONSTRUCTION

ATTACHMENTS

HIGH PERFORMANCE, HIGH VERSATILITY /

Getting more from your machines also means making them **more versatile**.
Designed for CASE machinery and tested by CASE engineers, each attachment enables you to take on a wider range of tasks, optimizing your performance across even the most demanding applications.

HYDRAULIC MULTIFIT "S" OILQUICK, CR, CS, CW and "G" TYPE QUICK COUPLER

Maximize safety, flexibility and performance

- + **Pick-up buckets from various brands and a wide variety of attachments including hammers**
- + **Hydraulic control from your cab, as well as compliance with all machinery directives & job site requirements**

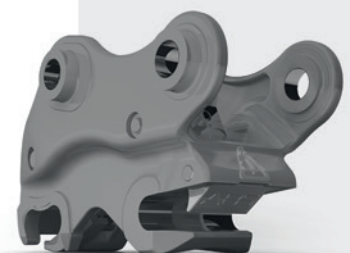

SMARTFIT

Be more efficient with our patented tooth system

- + **Hammerless fastener technology**
- + **Teeth that stay sharper for longer & penetrate deeper**



SILENT HAMMERS

Reduce operating costs with high-quality hammers for 1.2t to 80t machines

- + **Optimized weight/performance ratio and low-maintenance**
- + **Large tool diameter & fast tool replacement with simple and robust design**



WHEEL LOADERS & COMPACT WHEEL LOADERS

Fit the right bucket for each application

- + **Robust yet lightweight materials for a wide range of applications**
(rehandling, high-tip, & skeleton rock buckets, log grapples)

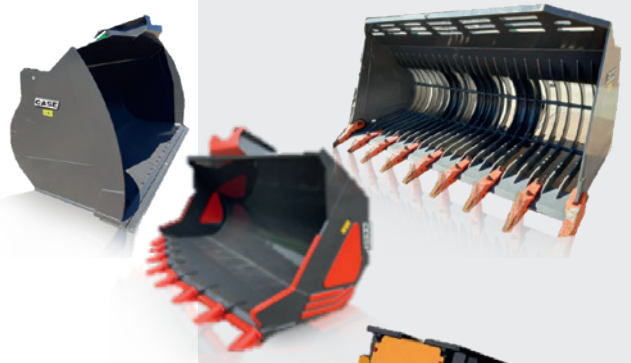

DEMOLITION LINE

Adapt to different phases with our plug and play kits for 1.7t to 80t machines

- + **Ideal for primary & secondary demolition phases**
(crusher, pulverizer, shear, selector & grapple)
- + **Available in multi-kit configuration**
(3 in 1 kit: crusher, pulverizer & shear)



ROAD LINE FOR SKID STEER LOADERS

Optimize your road construction & maintenance projects

- + **Cold planer version with integrated water tank, HF and EHF**
- + **Available within 15 working days and compatible with all-make machines using a universal control box**





CASE SERVICES SUPPORTING YOU AT EVERY STEP /

Our service offering is designed to provide support and expertise throughout your machine's lifespan. Whether focusing on maintenance, assistance or logistics, CASE services will help you minimize your downtime and maximize your performance.

Advanced assistance / Optimized maintenance / Efficient logistics

DISCOVER THE CASE SERVICE SOLUTIONS /

For maximum uptime and peace of mind, we've built an innovative 360° service package that covers every dimension of your machine maintenance and repair. With a proactive and preventive approach, you stay in full control.

CASE CARE

Maximize your machine's uptime and efficiency with this planned maintenance program.



CASE PROTECT

Avoid unexpected costs with this extended warranty program.



ServiceSolutions



CASE FLUID ANALYSIS

Ensure your machine's uptime with detailed fluid reporting.

myCASEConstruction

Boost your machine's profitability by tracking and managing your fleet's operating data.

CASE SITECONNECT

Connects your Dealer to your machine for remote support.





CASE CARE

YOUR PLANNED MAINTENANCE /

Designed for all CASE models, CASE Care provides proactive scheduled maintenance to anticipate your needs and prevent costly breakdowns. Your Authorized CASE dealer will regularly inspect and monitor your machine's condition, ensuring optimal performance with regular checkups and Genuine replacement parts, to stays ready to perform every day.

WHAT EXACTLY IS COVERED?

- 1 STANDARD MAINTENANCE**
and special application programs, with coverage of up to 10 years or 20,000 hours;
- 2 GENUINE PARTS AND CERTIFIED LUBRICANTS**
keeping your machine ready anytime
- 3 TECHNICAL EXPERTISE**
trained professionals and support you can rely on

WHY CHOOSE CASE CARE?

- + **MAXIMUM UPTIME** to keep your machine always in action with predictable operating costs
- + **PEACE OF MIND** planned maintenance and regular inspections reduce the risk of failure, ensure safer working conditions, and help comply with manufacturer warranty requirements
- + **HIGH PERFORMANCE** regular servicing maintains your machine's original performance, maximizing productivity on the job site
- + **HIGHER RESALE VALUE** a documented maintenance history ensures an increased resale value



CASE PROTECT YOUR EXTENDED WARRANTY /

Knowing your machinery is protected in the event of a breakdown, even beyond the standard warranty period, is both reassuring and cost-effective. That's why we developed CASE Protect warranty extensions that combine the benefits of Genuine CASE parts and trained technicians expertise directly in your local dealership.

HOW DO YOU BENEFIT FROM CASE PROTECT?

- 1 COMPREHENSIVE COVERAGE**
3 types of parts and labor coverage:
Powertrain, Powertrain Plus and Premier
- 2 FLEXIBLE ACTIVATION**
Order at machine delivery or up to
11 months from the start of your
base warranty
- 3 MAXIMUM PROTECTION**
Enjoy coverage for up to 60 months or 8,000
machine hours (including base warranty)

CASE PROTECT MORE FROM YOUR MACHINES

With Genuine replacement parts and expert repairs at your CASE dealership:

- + IMPROVED PROFITABILITY**
by keeping your machines working efficiently
- + HIGHER PERFORMANCE & RESIDUAL VALUE** over time
- + SAFER INVESTMENT** with protection against unexpected repair costs



CASE FLUID ANALYSIS

YOUR PREVENTIVE CARE /

The different fluids in your machine have an essential role to play in its performance and your safety. Contamination can lead to serious failures, shortening your equipment life and compromising progress on your work site.

By regularly checking your engine oil, transmission and hydraulic oils, coolant and axles, take action before any machine-stopping issues occur.

3 GOOD REASONS TO CHOOSE CASE FLUID ANALYSIS

1 PREVENT MACHINE FAILURE

quality checks reduce the risk of major breakdowns

2 MAXIMIZED RELIABILITY

by testing and detecting potential issues early

3 EXTENDED MACHINE LIFE

regular monitoring increases resale value

HOW DOES IT WORK?

- + Get your machine fluids checked by a case technician
- + Receive a detailed yet easy-to-read report
- + Carry out any preventive repairs at your CASE dealership

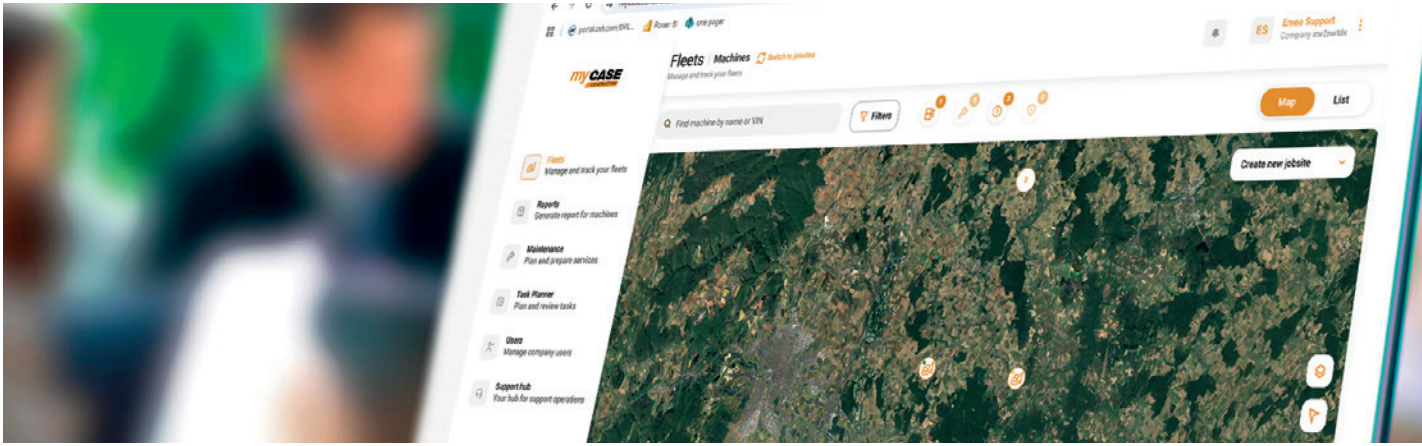

myCASEConstruction

YOUR PERSONAL ASSISTANT

myCASEConstruction puts all the benefits of centralized fleet control at your fingertips. The portal and app provides a comprehensive fleet overview, enabling quick action in case of anomalies, and giving you instruments to better organize your work, with jobsite management features, task assignment possibility and smart alerts.

WHY CHOOSE myCASEConstruction?

- 1 OPTIMIZE YOUR FLEET PERFORMANCE**
 Eliminate inefficiencies and low machine utilization, reduce fuel consumption with real-time information and optimize your jobsite efficiency thanks to the operator performance and tasks management.
- 2 CHALLENGE YOUR TCO**
 Increase uptime with better maintenance planning, compare fuel usage on machines and Return on Investment on different sites to make the right choices.
- 3 MORE SAFETY, LOWER INSURANCE PREMIUM**
 Prevent theft and unauthorized use with geo-fencing and curfew.

WHAT DOES myCASEConstruction MEAN FOR YOU?

- + Enhanced operations**
 Receive smart alerts to assist with jobsite planning and machine status monitoring.
- + Valuable planning**
 Identify performance trends, implement changes and monitor their impact
- + More profitability**
 Capitalize on the insights to recommend potential cost reductions

CASE SITECONNECT PROACTIVE SUPPORT & REMOTE ASSISTANCE

- Maximize machine uptime**
 Benefit from remote assistance & diagnostics from your dealer.
- Optimize service efficiency**
 Enable the dealer to investigate and resolve any issues quickly, including software updates.
- Lower Total Cost of Ownership**
 Predict your maintenance needs thanks to continuous monitoring systems that enable dealers to proactively plan and schedule maintenance.





LOGISTIC FOOTPRINT CAPABILITIES

PREMIUM SERVICE SUPPORT /

Keeping your machines running efficiently requires fast access to high-quality replacement parts. To reduce your downtime to a minimum, we've developed a vast European logistics network and tailored delivery options to meet all your requests as quickly as possible.

1 OPTIMIZED STOCK

With extensive stock in strategic warehouses and many more parts ready to be ordered, you're sure to find exactly what you need.

- **6 warehouses** across Europe
- **250,000 m²** of warehouse space
- **250,000 parts** permanently in stock
- **1 million parts** in our database
- Over **10 million items** dispatched each year

2 TIMELY DELIVERY

Thanks to an efficient integrated stock management system, you can get parts in record time with a wide choice of delivery methods including:

- **NEXT DAY DELIVERY** when you order before 6pm
- **DEDICATED SUPPORT** for 24/7 delivery
- **SELF PICK-UP** from the depot 2 hours after ordering

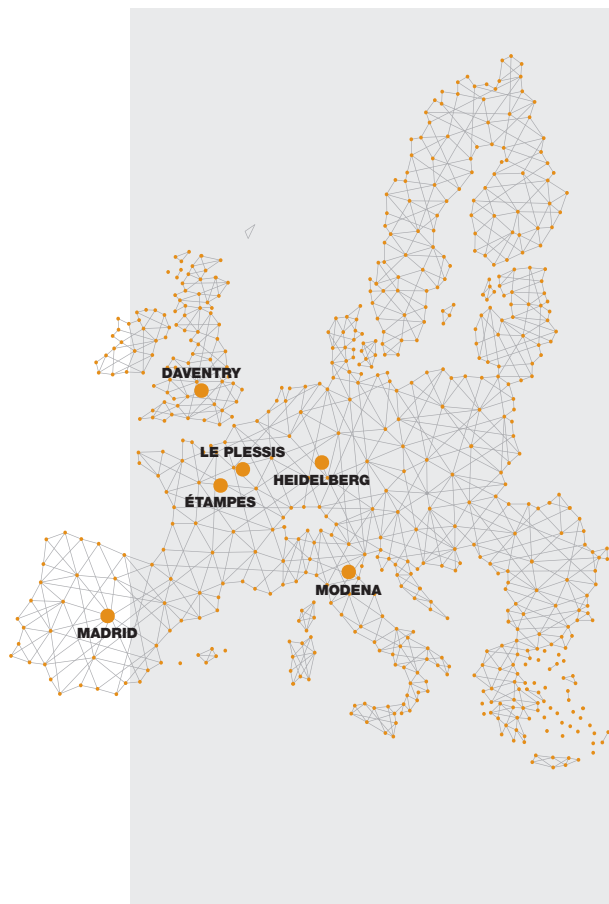

EFFICIENCY MAKES IT MIGHTY



Akcela[®]
At the true heart of your business

RECOMMENDED BY

CASE
CONSTRUCTION

AKCELA CASE is a wide range of lubricants and fluids designed for CASE Machinery. The range is the result of a technical, industrial and commercial partnership between Petronas and CASE:

- Testing in R&T to guarantee the release of international specs, to extend the life span of CASE machinery. The new products are developed to meet the Stage V emission limits;
- Original products to supply CASE plants for first fill, industrial equipment and aftermarket applications;
- Logistic and product distribution to ensure aftersales business activities and marketing actions.

AKCLEA CASE is the ideal solution for improving everyday performance and achieving top-class reliability and efficiency in construction industries.

CASE IH AGRICULTURE and CASE Construction Equipment are trademarks registered in the European Union and many other countries, owned by CNH Industrial N.V.

BUILDING A STRONG CASE.

Since 1842, at CASE Construction Equipment we have lived by an unwavering commitment to build practical, intuitive solutions that deliver both efficiency and productivity.

We continually strive to make it easier for our customers to implement emerging technologies and new compliance mandates.

Today, our global scale combined with our local expertise enables us to keep customers' real-world challenges at the center of our product development.

The vast CASE dealers' network is always ready to support and protect your investment and exceed your expectations, while also providing you with the ultimate ownership experience.

Our goal is to build both stronger machines-and stronger communities. At the end of the day, we do what's right for our customers and our communities so that they can count on CASE.

CNH Industrial
Deutschland GmbH
Case Baumaschinen
Benzstr. 1-3 - D-74076 Heilbronn
DEUTSCHLAND

CNH Industrial
Maquinaria Spain, S.A.
Avenida Aragón 402
28022 Madrid - ESPAÑA

CNH Industrial France, S.A.
16-18 Rue des Rochettes
91150 Morigny-Champigny
FRANCE

CNH Industrial Italia Spa
Lungo Stura Lazio 19
10156, Torino
ITALIA

CASE Construction Equipment
Cranes Farm Rd
Basildon - SS14 3AD
UNITED KINGDOM

NOTE: Standard and optional fittings can vary according to the demands and specific regulations of each country. The illustrations may include optional rather than standard fittings - consult your Case dealer. Furthermore, CNH Industrial reserves the right to modify machine specifications without incurring any obligation relating to such changes.

Conforms to directive 2006/42/EC

CASECE.COM
00800-2273-7373

The call is free from a land line.
Check in advance with your Mobile Operator if you will be charged. Toll free number not available from all calling areas.

