

ZOOM



GENUINE OIL FILTER EFFICIENCY & LONG LIFE

CASE IH MAKES THE DIFFERENCE.
LET'S SEE HOW.



GENUINEPARTS
HIGH PERFORMANCE

CASE IH

The key role of the oil filter.

Increasingly powerful diesel engines, increased power and torque, higher operating temperature and reduced fuel consumption; these engine constraints, together with longer oil change intervals, require increasingly enhanced lubricants. To ensure that the oil retains all its qualities over time, thereby guaranteeing the long life and performance of the engine, **the filtration system must be efficient and perfectly reliable.**

The primary function of the filter is to retain all the particles which have an abrasive effect on the mechanical rotating parts such as the crankshaft, the camshaft, the valves and the turbocharger.



Next, it is essential that the filter can store all the particles accumulated until the next oil change.

There are three types of particles which accumulate:



COMBUSTION RESIDUES



WEAR RESIDUES

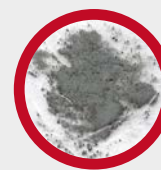

DUST



Why choose Genuine CASE IH oil filters?

ESSENTIAL PROPERTIES OF THE FILTER. A GENUINE CASE IH OIL FILTER OFFERS TWO KEY ADVANTAGES:

HIGH-QUALITY FILTRATION

CASE IH Genuine filters have a high-tech internal structure: **The multilayer medium.** Made from three layers of synthetic material, it offers a higher filtration capacity and resistance.

MULTILAYER MEDIUM

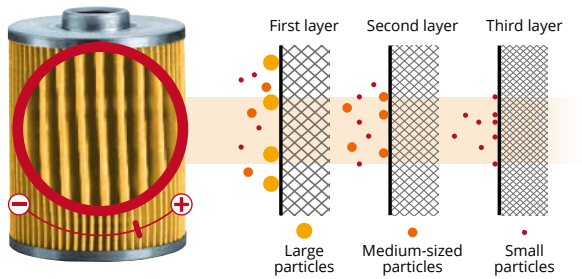

5X MORE EFFICIENT:

Genuine CASE IH oil filters have a retention efficiency percentage which is 5 times higher than standard filters.



OPTIMAL, LONG-LASTING LUBRICATION

For optimal, long-lasting lubrication with no premature wear to mechanical parts, the oil must be pure.

EXAMPLE OF OIL FLOWING THROUGH A CIRCUIT

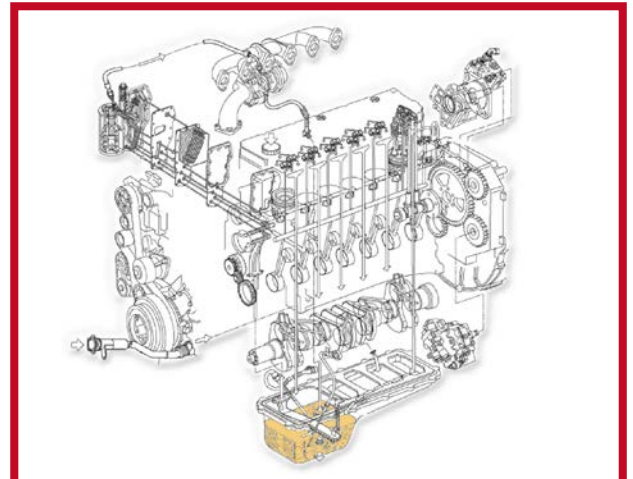

The retention efficiency and optimal flow rate of the oil also guarantee **IMPROVED COLD STARTING WHATEVER THE OUTSIDE TEMPERATURE.**

Outdoor temperature (in °C)

+30°

+15°

-10°



Oil flow rate capacity via oil filter (in %)

100%

100%

75%

Recommendations for use

MAINTENANCE INTERVALS.

TO GUARANTEE OPTIMUM ENGINE PERFORMANCE UNTIL THE NEXT MAINTENANCE SERVICE, YOU NEED:

SUPERIOR QUALITY OIL

AKCELA®

A GENUINE OIL FILTER



GENUINE OIL FILTERS ARE PERFECTLY SUITED TO THE MAINTENANCE INTERVALS DEFINED BY CASE IH:

PUMA 230 CVX TRACTOR



600 Hours*

AF9120 COMBINE HARVESTER



600 Hours*

QUADTRAC 620



600 Hours*

* Duration generally observed, please refer to your vehicle maintenance manual or the filter booklet for more information.

It is recommended to change the engine oil and replace the filter during each maintenance operation.

DEPENDING ON THE VEHICLE USE AND THE CONDITION OF THE OIL CHANGED, DO NOT HESITATE TO CHANGE THE OIL MORE FREQUENTLY.



caseih.com