

# MAGNUM





THE SUCCESS STORY .....	04 - 05
WALKAROUND .....	06 - 07
CAB AND CONTROLS .....	08 - 13
ENGINE .....	14 - 15
FULL-POWERSHIFT TRANSMISSION .....	16 - 17
CONTINUOUS VARIABLE TRANSMISSION .....	18 - 19
PTO .....	20 - 21

HYDRAULICS .....	22 - 23
DRIVELINE .....	24 - 25
ROWTRAC .....	26 - 29
ADVANCED FARMING SYSTEMS .....	30 - 33
SERVICE .....	34 - 35
SYSTEM SOLUTIONS .....	36 - 37
SPECIFICATIONS .....	38 - 41



# MAGNUM READY FOR THE CHALLENGES AHEAD WITH MORE POWER FOR TOUGH CONDITIONS.

**AFTER MORE THAN 170 YEARS WE REMAIN TRUE TO OUR VISION OF PROVIDING THE FARMERS OF TOMORROW WITH AGRICULTURAL MACHINERY THAT IS ALWAYS AN INNOVATIVE, RELIABLE AND PROFITABLE INVESTMENT**

Case IH has played a major role in shaping agriculture, with legendary brand names that include Case, International Harvester and David Brown. As the inventor of the Axial-Flow single rotor threshing and the hydraulic reversing gear, and as the pioneer of the continuously variable transmission, the Case IH heritage goes on. The pioneering vision of our forebears remains at the heart of every Case IH product to this day. It is with the same passion that we develop and produce agricultural machinery in Europe and across the world. More than 150,000 Case IH Magnum and Magnum CVX tractors in operation are testament to our dedication to meeting and exceeding the expectations of farmers across the world.

This wealth of experience has given us the opportunity to listen to you and design products that deliver precisely what you need. We demand of ourselves and our dealers the same high level of quality in the service we provide together to our customers. Our network of 391 dealers, 679 dealer branches and sub-dealers and 1,377 Case IH Service Centres in Europe is your guarantee of personalised and professional service. That is how we work and earn the trust of our customers.

**THE PROVEN MAGNUM SERIES, TRACTOR OF CHOICE OF LARGE SCALE FARMERS AND CONTRACTORS, CONSISTENTLY DELIVERS ON PRODUCTIVITY AND MAKES A PROFITABLE INVESTMENT.**

First launched in 1987, the Magnum Series has evolved over 27 years to become the first choice of large scale farmers and contractors who demand the best. The new Magnum powers through every task fast and efficiently, reliably delivering impressive productivity day after day. No day at the wheel will feel too long with the Magnum's luxuriously comfortable cab, intuitive controls ergonomically laid out, quiet operator environment and smooth ride. And when the working day stretches to well after dark, the powerful 360-degree LED lighting package turns night into day, so you can get the job done. The Magnum Rowtrac now provides even more infield performance with all the benefits of tracks, such as greater ground contact, increasing traction and reducing ground pressure whilst keeping the benefits of a conventional tractor with less ground disturbance when turning, power turns and differential lock.

MODELS	Rated power ECE R120 <sup>3)</sup> @ 2,000 rpm (kW/hp(CV))	Maximum power ECE R120 <sup>3)</sup> Power Management @ 1,800 rpm (kW/hp(CV))	Capacity (cm <sup>3</sup> )	Number of cylinders
Magnum 250 FPS / CVX	184 / 250	235 / 320	8,700	6
Magnum 280 FPS / CVX	206 / 280	258 / 351	8,700	6
Magnum 310 FPS / CVX / Rowtrac	229 / 311	281 / 382	8,700	6
Magnum 340 FPS / CVX / Rowtrac	250 / 340	301 / 409	8,700	6
Magnum 380 CVX / Rowtrac	279 / 379	320 / 435	8,700	6

<sup>3)</sup>ECE R120 correspond to ISO 14396 and 97 / 68 / EC or 2000 / 25 / EC

# 27 YEARS OF MAGNUM TRACTOR LEADERSHIP THE SUCCESS STORY

The success of Case IH is based upon a strong past. As a result of continuous growth and development, today we are the second largest manufacturer of agricultural machinery in the world. Thanks to continuous development and expansion of our range, Case IH now offers the widest ever portfolio of products to our clients.

**1987**

The first Magnum tractor series is launched, with horsepower ranging from 160 to 240 hp.



**1993**

The Magnum 7200 Series is launched and sets a new industry standard in farm power, technology, innovative-oriented customer convenience, quality and value.



**1998**

Launch of the MX Magnum tractors feature higher traction due to better weight distribution, a smoother ride and much better visibility all the way around.



**2004**

Acting as trendsetter once again, Case IH is first to introduce factory installed Guidance system on MX Magnum.



**2007**

Launch of Magnum models 225, 250, 280 and 310 with the first touchscreen display AFS Pro 600 and enhanced field and road autoshift functions.



**2009**

APM - Automatic Productivity Management feature is launched in the Magnum Series for best fuel efficiency.



**2012**

The Magnum celebrates its 25th anniversary.



**2014**

Case IH launches Magnum CVX models ranging from 250 hp to 380 hp and celebrates the milestone of 150,000 Magnums built.



**2015**

Case IH Magnum 380 CVX voted Tractor of the Year 2015 and launch of Magnum Rowtrac.





# THE MAGNUM RANGE PRODUCTIVITY DRIVES HIGH RETURNS

## EVERYTHING YOU WANT YOUR TRACTOR TO BE – AND MORE:

Big on power and efficiency, comfort and intuitive operation, the new Magnum drives productivity to new heights and slashes ownership costs. The new Magnum brings reliable technology to your business and a high return on your investment.



### SUPREME COMFORT

You won't feel tired after long working days on the Magnum, with the low noise levels, climate control and excellent visibility of your front and rear implements. The new split wide angle mirrors enable you to keep an eye on your trailer or grain cart in haulage applications. The 360-degree LED lighting package will enable you to carry on working after dark without slowing down. The 5-point suspension system (cab, seat, axle and front and rear linkage) will provide a remarkably smooth ride.



### INTUITIVE OPERATION PUTS YOU IN CONTROL

You have a clear overview of all your Magnum's functions: the Integrated Control Panel gives you all the key information at a glance and the AFS™ Pro 700 screen integrates the data from the tractor and implement. The new multi-function handle makes operation even easier; it has more pronounced tabs on the buttons so you can recognize them by touch, and they are backlit for night work. Your Magnum's controls are all at your fingertips.

### ADVANTAGES

- Best comfort thanks to 5-point suspension system
- 360° LED lighting package
- Full power to the ground with Magnum Rowtrac
- Fully integrated AFS AccuGuide autoguidance solution





### **POWERFUL EFFICIENCY UNDER THE BONNET**

The powerful 8.7 litre, 6-cylinder engine is designed to generate power and optimize fuel efficiency. The flatter torque curve of the new Magnum delivers maximum torque at a greater range of engine speeds. Stage IV emissions standards are achieved with our proprietary high efficiency Hi-eSCR after-treatment system that delivers extra power and fuel efficiency with an unbeatable rpm performance and no power losses.



### **POWERFUL IN THE FIELD AND ON THE ROAD**

You can choose the proven Full Powershift Transmission with Automatic Productivity Management (APM) that automatically reduces engine speed to match power requirements. Or you can opt for the Continuously Variable Transmission that makes the Magnum CVX the perfect all-rounder on the road and in the field, driving automatically from 0 to 50 kph.



### **BORN TO BE STRONG**

With the new Magnum you can count on a lift capacity of 10,927 kg, a fully integrated front linkage with a lift capacity of up to 5 tons, and you can also add an optional front PTO. If you need to operate big implements with your Magnum that require high hydraulic flow, you can opt for the twin-flow 282 litre hydraulic pump. You can have up to 6 electro-hydraulic remote valves.



### **PUTTING POWER WHERE YOU NEED IT**

Where traditional tyres simply aren't enough, Magnum™ Rowtrac provides better handling and ride, less rutting and berming, and full power on the ground in curves and turns. The Magnum Rowtrac turns like wheels, floats like tracks.



### **AFS: MAXIMISE RETURNS WITH PRECISION FARMING**

The integrated AFS™ Pro 700 touch screen gives you all the key data, from fuel consumption to engine and PTO power, at a glance. It also enables you to adjust the settings easily and quickly for different implements and working conditions. The Magnum is ISOBUS ready to control compatible implements. To maximise your efficiency, you can choose from a full range of guidance solutions, offering accuracy levels of up to 2.5 cm.



- A** LEFT-HAND CAB STORAGE AREA
- B** INSTRUCTIONAL SEAT
- C** LUXURY CARPETED FLOOR  
REDUCES NOISE LEVELS FROM  
TRANSMISSION/DRIVETRAIN
- D** HEATED AND VENTILATED  
SEAT WITH EXTENDABLE/  
RETRACTABLE LOWER  
SEAT CUSHION
- E** AFS PRO 700 TOUCH SCREEN
- F** MULTICONTROLLER ARMREST
- G** AIR FILTRATION AND AUTO  
CLIMATE CONTROL  
(NOT SHOWN)





Everything is easily adjustable to customize your own workstation.



Supreme comfort offered by Semi active red leather seat with positive response, heated and ventilated cushion and automatic seat suspension.

# COMFORTABLE AND QUIET FOR LONG DAYS

If you were to describe the cab of your dreams, we have no doubt that the Magnum Surveyor cab would fit the bill to perfection. As you step into the cab, prepare to be delighted: the luxurious feel of the quality leather upholstery, the ergonomic suspended seat, the controls strategically placed within easy reach... everything in the Surveyor cab is designed to give you the best feeling of supreme comfort behind the wheel. Put yourself first; choose the Magnum.

## A WORKSTATION TAILORED TO THE OPERATOR

Every element – steering wheel, seat and Multicontroller armrest – is easily adjustable so you can customize your workstation perfectly to give you the best and healthiest driving position.

## THE IDEAL WORKING ENVIRONMENT

The exceptionally low noise levels of just 67 dB(A) and automatic air conditioning create your ideal environment and internal climate. The carpeted floor in the optional Luxury cab adds to the feeling of comfort and further reduces noise levels. Days at the wheel of your Magnum will fly by as you get more work done than ever.

## SUPREME COMFORT

The semi-active heated and ventilated leather seat with adjustable cushion gives you the luxurious ride you would only expect from a premium saloon car. The automatic seat suspension reacts to the individual driver's weight to provide an optimally smooth ride on a rough drive. The passenger will also ride in comfort on a seat, also available in red leather, featuring a backrest and homologated safety belt.

## STAY CONNECTED

You can stay connected throughout the day with the new radio with Bluetooth and plug-in mobile connection.

# WORK LONGER AND STAY FRESHER 24/7 EFFICIENCY IN ANY CONDITIONS

## FOR WHEN YOU NEED TO WORK AT NIGHT

The cab's panoramic view provides excellent visibility all round, while the bonnet has been designed to guarantee a perfect view of all your implements. For those days when you need to carry on working after dark, you can turn on the bright LED lighting package that will illuminate perfectly 360 degrees around the tractor, giving you perfect visibility of your implements – even the outermost row units of your largest planter. With 34,400 lumen lighting power, you will be working in clear light conditions – anything you need to do to get the job done efficiently.

## SMOOTH RIDE – 5 POINT SUSPENSION SYSTEM

The Magnum has pulled out all the stops with its full suspension package; the suspensions on the seat, cab, axle, and front and rear linkage are adjusted to perfection. The suspended front axle design on the Magnum tractors isolates the driver from shocks. When you sit at the wheel of a Magnum, you will experience the smoothest ride of your life.

## TYRES TO THE GROUND

The Magnum's front axle suspension keeps all your wheels on the ground, so that you enjoy the best stability, traction and control over rough terrain. Whether you are riding over uneven ground or at high speed, this simple design ensures you don't have a bouncing and jarring ride and delivers all the power to the ground. It also has the added advantage of requiring less maintenance than other systems because of its solid construction. With this suspension, the Magnum will take you wherever you need to go – comfortably and safely.





The suspended cab provides you a smoother ride whether on the road or in uneven terrain.



Full stability, a smooth ride and full power to the ground thanks to the front suspension.



All information on the tractors performance at a glance.

# INTUITIVE OPERATION PUTS YOU IN CONTROL

We know how busy you and your operators are, so we make sure you don't waste time getting used to a new control layout when you switch tractors: in every Case IH tractor, from a Maxxum to a Quadtrac, you will find the same control layout. The moment you sit in the cab, you know where everything is, you have all the information you need at a glance on the A-Post display and all the controls at your fingertips on the Multicontroller armrest. Comfort and control – no time wasting.

## CONTROL STATION

Multicontroller featuring drive logic, the ICP intuitive control panel and the AFS Pro 700™ touch screen monitor integrate all the tractor's functions into the armrest, putting all the controls at your fingertips: speed selection, direction changes, throttle, AccuGuide engage, Headland Management Control, electronic remote valves, rear hitch controls, PTO, joystick ... everything is in one place within easy reach. Operation is so intuitive that a novice driver would have no problem working at his best from day one.

## OPTIMISE YOUR PERFORMANCE

The AFS Pro 700 gives you all the information you need on the tractor's performance, from fuel consumption to engine and PTO power, at a glance. The touch screen interface is easy to use and you can quickly adjust the settings for different implements and working conditions. To make it even more intuitive, you can customise the different screens to display the information most important to you.

## EVERYTHING UNDER CONTROL

The ICP performance instrumentation cluster on the A-Pillar tells you everything you need to know about the tractor – engine speed, transmission target speeds, actual ground speed, brake position and drive direction, everything is clearly displayed in one place so you have everything under control.



- A AFS PRO 700 TOUCHSCREEN
- B MULTICONTROLLER
- C REMOTE VALVE CONTROLS INCL. JOYSTICK
- D ICP – INTUITIVE CONTROL PANEL
- E FRONT-/REAR PTO ON/OFF
- F HYDRAULIC CONTROLS

# FIELD LEADING POWER AND PERFORMANCE

At the wheel of a Magnum tractor you enjoy the full benefit of the high efficiency, low emissions engine technology knowhow of our in-house engine specialist, FPT Industrial. They bring to bear the experience developed on thousands of engines running around the world in on- and off-road applications in the development and production of engines that meet the specific requirements of agricultural tractors. All Magnum models meet Stage IV emissions regulations with the patented high efficiency Selective Catalytic Reduction (Hi-eSCR) technology developed by FPT Industrial for Case IH. This is an evolution of the proven Stage IIIB solution and delivers class-leading power with no compromise on efficiency. As a result, Magnum tractors develop more horsepower with less fuel, are more responsive and reliable – all with the extremely low Stage IV emissions levels.

## POWERFUL IN ALL OPERATIONS

The Magnum's 8.7 litre, 6 cylinder common rail turbocharged intercooled engines are designed to deliver massive power efficiently. Engine power management gives you the power you need when you need it – with frugal fuel consumption: 10% power growth at 1,800 engine rpm and, if under load engine rpm drops, Engine Power Management unleashes up to 36 more horsepower, giving you the boost you need to deal with the most difficult conditions.

## POWER BOOST TO MATCH THE CONDITIONS

The Magnum 280, 310, 340 and 380 feature an electronically variable geometry turbocharger, which adjusts the aspect ratio, optimising it according to the changing conditions. The variable geometry turbocharger adapts, reducing the aspect ratio at low engine speeds so that it is able to produce a boost at lower speeds, and increasing the aspect ratio at high speeds, so that the turbo doesn't choke and power output is delivered efficiently.

## POWERFUL FUEL EFFICIENCY

In addition to the fuel efficiency deriving from our Hi-eSCR technology, the Magnum 380 delivers best-in-class 1,850 Nm maximum torque – more than any other tractor on the market. The flatter torque curves mean that the new Magnum delivers maximum torque at a wider range of engine speeds, from 1,300 to 1,400 rpm. This results in further fuel economy, as the engine delivers more power on lower engine rpms – and optimal transmission of power is guaranteed.





- ADVANTAGES**
- FPT engine technology from 250 to 379 hp (rated) all Stage IV compliant
  - Engine Power Management boosts power from 320 to 435 hp
  - APM Automatic Productivity Management and ECO Drive helps to cut fuel consumption
  - 600 hour service interval



Perfect integration of engine and transmission – FPT Industrial in house engines.

MAGNUM 380 CVX

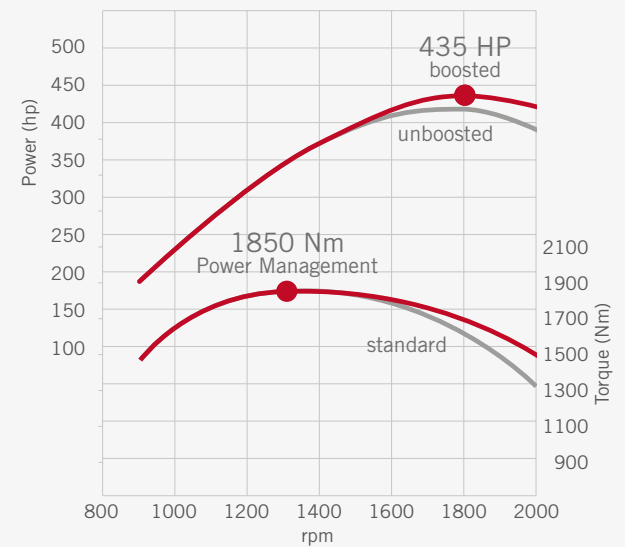

36 HP additional with Power Boost.

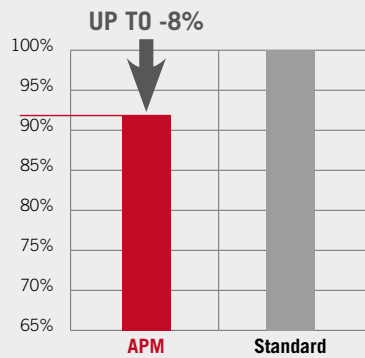

Auto Road: reduced fuel consumption by using this mode.

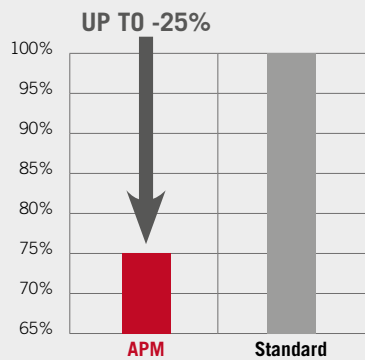

Auto Field: increases productivity.



23x6 Full Powershift Transmission with creeper.







**ADVANTAGES**

- 19x4 Full Powershift transmission 50 kph
- 23 x 6 Full Powershift with creeper
- Diesel Saver™ Automatic Productivity Management (APM) system optimising tractor efficiency

# FULL POWERSHIFT TRANSMISSION: TRANSMIT EFFICIENT POWER IN YOUR FIELDS

The automatic shift of the Magnum's Full Powershift transmission ensures you shift seamlessly from zero to 50 kph. When you have jobs to do at slow speed, you can choose the optional creeper transmission with 5 forward and 2 reverse speeds, and it does it with exceptional fuel efficiency, as the Diesel Saver™ Automatic Productivity Management (APM) system automatically adjusts gear setting and engine speed to the most fuel-efficient mode.

**OPTIMAL EFFICIENCY – THANKS TO APM**

On a Magnum tractor, you can keep your focus on your work while the APM takes care of optimising efficiency by shifting up and throttling back automatically to minimise fuel consumption.

You can select Road or Field mode, so that the APM will continuously optimise the tractor's efficiency according to the conditions. When working in the field, you can set a fixed speed at up to 23 kph with the throttle lever and Auto Field function will shift up or down and change engine speed, continuously adjusting according to the job and terrain.

On the road, you can set a variable forward speed within a range (1.2 kph to 50 kph) and the Auto Road function will adjust engine speed and change gears to maintain the best fuel efficiency at all times.

19x4 Full Powershift transmission 50 kph

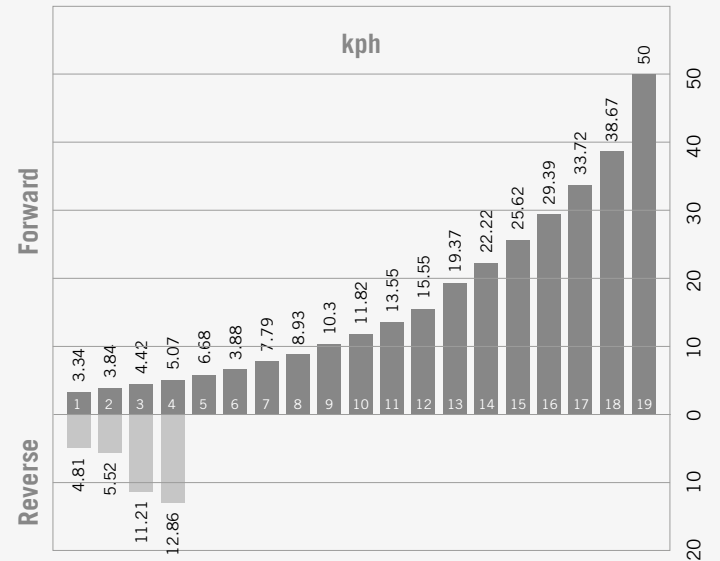

# CVX TRANSMISSION: FULL POWER TO THE GROUND

Step into the world of supreme efficiency with the Magnum's CVX continuously variable transmission. Available on all models of the range and standard on the Magnum 380, 50 kph transmission with active hold.

## **SUPREME FUEL EFFICIENCY AT ALL TIMES**

The Magnum CVX is designed to operate with extreme fuel efficiency in all applications and conditions, and to ensure you never waste fuel. On the road, it reaches 50 kph at just 1,400 rpm, so you save fuel for every tonne you transport. In the field, in specialist applications at low speed, the integrated creeper, independent of engine speed, ensures an economical performance and the Automatic Product Management (APM) automatically adjusts engine speed to the power requirements.

## **FULL POWER TRANSFER**

The Magnum CVX's transmission transfers power from the engine to the transmission mechanically, ensuring the full power is transferred to the ground without dispersion.

## **ACTIVE HOLD CONTROL ON SLOPES**

The Magnum CVX makes it easy for you to work in all conditions, even on steep slopes, with the Active Hold Control, standard on all CVX models, which prevents the tractor from rolling back when you stop on a hill and enables you to pull away again without having to use clutch or brakes.

## **ECODRIVE™ – THE INTUITIVE WAY TO SAVE FUEL**

Using the ECO split throttle lever the driver can fix a certain minimum and maximum engine speed to match the engine performance and efficiency to each job. Then the Magnum CVX watches for optimum fuel efficiency.





- ADVANTAGES**
- Continuously variable transmission 50 kph
  - APM Automatic Productivity Management for best fuel efficiency
  - Active Stop holds the tractor with load stationary without applying the brakes



CVX transmission – stepless drive between 0-50 kph



Outstanding performance. Choose your speed between 0 to 50 kph.

# MASSIVE PTO POWER AT LOW ENGINE RPM

The higher engine power of the new Magnum comes with a PTO to match, as the heavy duty 1,000 rpm PTO delivers its best performance on full engine power. Alternatively, you can opt for the 540/1,000 rpm with interchangeable shafts.

## QUIETLY POWERFUL

The rear PTO delivers 1,000 or 540 rpm at peak engine power at 1,803 engine rpm, which cuts down fuel consumption and noise. In addition, the positioning of the PTO clutch on the top shaft results in even quieter operation. Both the 1,000 and 540/1,000 PTOs will easily run any implement you may be pulling. The hydraulically activated and electronically controlled system allows for smooth modulation and protects the components.

## EASILY EFFICIENT OPERATION

When you need to change implements, the PTO shaft is easy to rotate for easy coupling. With PTO Management, you can make sure that the PTO and implements run most efficiently by selecting 'Auto' or, if you are running heavy implements such as wood chippers or large balers, 'Heavy' mode.

## OUTSTANDING FRONT PTO

The 1,000 rpm front PTO runs on equally excellent engine speed of 1,804 rpm and delivers a maximum power of 230 hp with its 1.3/8-inch shaft and 6 splines.





#### **ADVANTAGES**

- 540 or 540/1000 rear PTO aligned to maximum engine power
- PTO Management
- Soft start PTO takes care of your implements
- Front PTO for greater productivity



Seamlessly integrated Front Linkage with a lifting power of 5,000 kg.



No limits of operation with 6 electronic-hydraulic rear remotes.

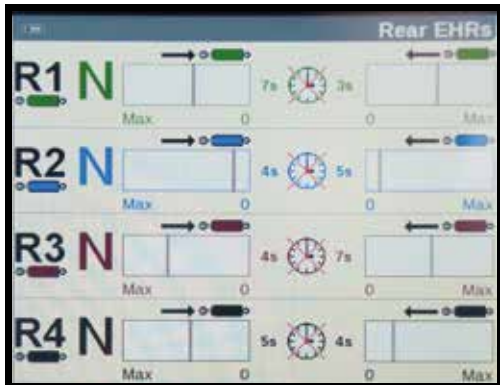

Control your remote valves with the AFS 700 Pro Monitor.



Easy and safe operation with the external controls.



#### ADVANTAGES

- Industry leading 10,927 kg lift capacity at the rear
- Up to 5,000 kg front lift capacity
- Up to a massive 282 l/min flow for high demand implements
- 6 electronic remote valves with temperature compensation

# VERSATILE CONNECTION FOR ANY KIND OF IMPLEMENT

With a maximum lift capacity of 10,927 kg, the hydraulic system is designed to give you all the lifting power you need, optimising fuel consumption. Powered by a standard pump that delivers 166 litres per minute, a high flow 228 l/min pump or, for the biggest implements, a 282 l/min twin flow with two variable displacement pumps, the Magnum's hydraulics have all the lift power you may need. A load sensing power beyond system is standard, providing the possibility to operate additional auxiliary functions. The automatic flow compensation reduces fuel consumption, so you get the full benefit of the Magnum's lift power and economy.

#### EFFICIENT VERSATILITY

The Magnum's advanced hydraulics system with Pressure Flow Compensating (PFC) design and up to 6 electro-hydraulic remote valves enables you to operate in a wide variety of applications without having to stop and reconnect hydraulic hoses. Made at our plant in Racine, USA, the remote valves deliver the power you need with 140 l/min per valve.

#### EASY OPERATION

The remote valves are easy to operate, by turning a knob or via the display's touch screen. From the driver's seat you can set six function remote lever controls – for orbital motor, loader, full function, no float and lock – and with the programmable valve timer you can set repeatable engagement times without leaving the cab. A power beyond supply is available for hydraulic power supply, return, load sense and case drain, for easy hook-up to pull-type sprayers. A power beyond can also be factory fitted so that you can control it from the Multicontroller armrest.

#### HEAVY-DUTY HITCH AND DRAWBAR FOR BIG IMPLEMENTS

The Magnum's versatility is further extended by the heavy-duty hitch and drawbar with standard electronic draft control, which provide up to 10,200 kg lift capacity so that you can also work with wider and heavier implements. You can adjust the maximum slip according to your application with Slip Limit Control and minimise bouncing during transport with a mounted implement with Hitch Ride Control.

#### INTEGRATED FRONT LINKAGE

You can give a further boost to your productivity with the fully integrated front linkage, which delivers a power lift up to 5,000 kg and offers a PTO option and external hydraulic couplers to enable you to connect a front implement with separate hydraulic components.







# YOUR MAGNUM – JUST THE WAY YOU WANT IT

The Magnum delivers a massive performance: you want to be sure you have the right driveline that will bring all this power to the ground in your field. Power is nothing if you don't have the correct tyres, axles and ballasting, all factory fitted.

## **TYRES**

You can choose from a wide offering of tyres, those that will provide the best traction and least slippage in your farming operation. You can choose tyres up to 2.15 metres diameter to transfer the Magnum's massive power to the ground.

## **BALLASTING**

Select just the right ballasting package for your Magnum and consider the rear wheel ballast with integrated wheel weights, which brings even more power to the ground.

## **FRONT AXLE**

The Magnum models up to 250 hp feature a Class 4.75 front axle. Models above 250 hp are available with a Class 5 axle manufactured at our plant in Racine, USA, which has a significantly higher suspended load capacity and further reduces cab bounce, improving the driver's comfort. It also delivers better traction in fieldwork and better handling performance in high speed operation.

## **REAR AXLE**

All Magnum models feature a standard 98 inch bar axle, but different axles are available to match the varied needs of different models. The clutch capacity of the park brake and 4WD were increased to match the higher power and heavier weight of the new Magnum models. And if you need even more, the Heavy Duty Rear Axle available on the Magnum 340, in both Full Powershift and CVX models gives you more lift capacity, 75 mm more hitch lift height, and you can have the new heavy duty PTO clutch for the heavy duty application such as bale grinders or feed mixers.



Transfer massive power to the ground.



Wide offering of Tyres and Ballasting packages.



Unbeatable Turning Radius of 4.8 m.

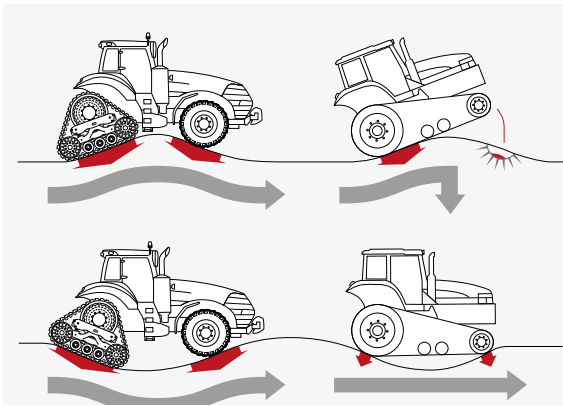

Optimum riding comfort and ground contact area.

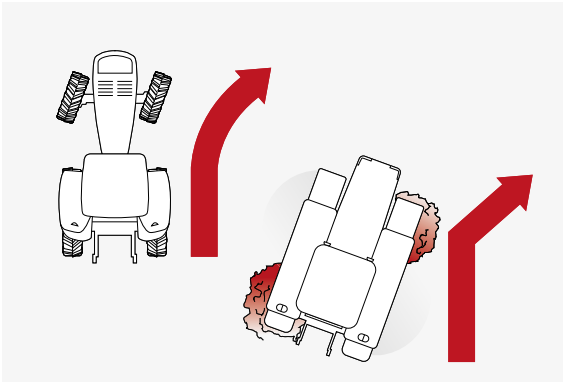

Power to the ground 100% of the time even when turning, unlike twin track machines.



Magnum Rowtrac follows the same concept as Quadtrac with four points of contact to the ground.



- ADVANTAGES**
- Turns like wheels and floats like tracks
  - Designed to run on tracks
  - Tracks designed and built by Case IH
  - 3 models available with 310, 340 and 380 hp(CV)
  - 100 % power transfer with positive drive



# GREATER WEIGHT DISTRIBUTION STAY ON TOP OF THE FIELD

Better flotation, improved manoeuvring and more flexibility - three reasons why the new Magnum Rowtrac is the best solution for the way you farm. If you farm in a region where wet soil conditions can delay drilling and, therefore, crop establishment, Magnum Rowtrac will enable you to get on the land when other tractors cannot. Enjoy longer planting windows, better tractive power, reduced compaction and rutting, and make long days more productive. Magnum Rowtrac – built to fit the way you farm.



## UNDERCARRIAGE

- The track assembly consists of a positive drive wheel, two idlers and three rollers at the bottom.
- The rollers are isomounted to absorb shock and compensate a rolling terrain of a road.
- The track is automatically tensioned similar to the Quadtrac design.



## POSITIVE DRIVE

- This design eliminates slippage between the drive wheel and track because the positive drive is continuous in all conditions at all times.
- Tracks are designed and built by Case IH.



**ADVANTAGES**

- Reduced soil disturbance due to conventional steering axle
- Superior ride quality and stability
- 61 cm and 76.2 cm track widths
- 193 cm, 203.2 cm and 223.5 cm row spacing

# REDUCED SOIL DISTURBANCE WITH INCREASED TRACTION

Magnum Rowtrac tractors are designed to strike the perfect balance, with tyre options that fit your row width and soil type and an oscillating rear-track design that keeps the power on the ground through the tightest turns. These tractors keep four points of ground contact, which reduces surface pressure and means less weight transfer from front to rear than two-track systems. And it offers manoeuvrability and handling comparable to a wheeled tractor.

## THE TRACK DESIGN THAT CHANGED THE INDUSTRY

This rear track oscillates and pivots to maintain a flat footprint that keeps the power on the ground. This design produces traction that is unaffected by hitch or drawbar load, plus improved ride over uneven terrain.

## CUSTOMIZED TO FIT YOUR ROWS

No matter what your farming enterprise is, the Magnum Rowtrac undercarriage design adapts to fit the way you farm. A wide range of axle spacing options gives you the flexibility you need for applications such as controlled traffic farming (CTF).

## AVAILABLE ROW SPACING AND TRACK WIDTHS

- Available Row Spacing: 193 cm, 203.2 cm and 223.5 cm
- Available Track Width: 61 cm und 76.2 cm



Wheels and tracks keeps in contact with the ground for maximum traction.

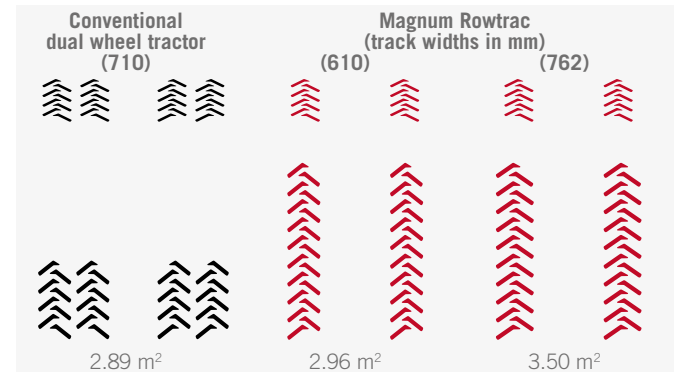

Magnum Rowtrac offers the benefit of a larger contact area than a dual-wheeled tractor but with reduced outside width for easier road transportation.



Superior ride quality and stability in the field.

**AFS SUPPORT CENTER**



0800 0281 910  
afsupporteur@caseih.com



**ADVANTAGES**

- GLONASS/GPS Antenna
- Low cost RTX signal solution
- Optional High Accuracy RTK Signal
- Integrated AccuGuide AutoGuidance
- Virtual dashboard with parameter monitoring
- Alerts when a predefined value is breached such as a geo fence



**AFS AccuGuide: GPS and GLONASS based guidance for ultimate precision independent of crop conditions. Accuracy levels down to 2.5 cm available.**



**xFill bridges RTK signal gaps up to 20 minutes.**



**Accurately pinpoint all machines with AFS-Connect™.**

# CASE IH ADVANCED FARMING SYSTEMS SUCCESS WITH PRECISION

Case IH Advanced Farming Systems® (AFS) have been at the forefront of precision farming for more than a decade, giving farmers the ability to control the entire crop production cycle. Case IH AFS® tools include everything you need to achieve repeatable accuracy down to 2.5 cm, reduce overlaps and cut input costs – and maximize your yield potential.

## **ADVANCED VEHICLE CONTROL.**

If it's interactive vehicle set-up and control you need then look no further than the AFS Pro touch screens: monitor yield, fuel usage and work rates, connect external cameras, keep job records and manage ISOBUS implements. The AFS Pro touch screens are interactive, fully customizable and portable between your Case IH fleet.

## **VEHICLE GUIDANCE SOLUTIONS.**

If it's a guidance system you are looking for, we have simple 'plug and play' lightbar steering kits through to fully automated and integrated solutions (AccuGuide). The accuracy you need depends on your requirements. With the range topping RTK systems we can make you pass perfect down to 2.5 cm. The xFill option can bridge RTK signal gaps up to 20 minutes.

## **AFS FARM MANAGEMENT SOFTWARE.**

Many variables apply in farming; it is key to understand what is happening and why. It's time to manage your farming operation on a new level by making decisions based on facts. With the AFS® Farm Management software package from Case IH you can see, field by field, the tasks performed, the work rates achieved, the fuel used during each task and, most importantly, your yield. Plan for the future today.

## **AFS CONNECT™ TELEMATICS.**

The Case IH AFS Connect™ telematics system allows farm owners and managers to monitor and manage their machinery from the farm office, tracking machines in real time on the farm computer to observe how they are performing, through the use of precision guidance GPS signals and wireless data networks. Analysing the data it provides helps to improve logistics, minimise fuel consumption and maximise performance.



Performance monitoring.



Vehicle settings.



ISOBUS compatibility.



### ADVANTAGES

- Intuitive AFS Pro 700 touch screen
- Control implements with ISOBUS connection
- Headland Management Control automates up to 32 end of row functions
- Improved productivity with up-to-the-minute information





# INTEGRATED PRECISION FOR MAXIMUM PRODUCTION

Case IH Advanced Farming Systems are within easy reach on the AFS Pro 700™ touchscreen monitor, integrated into the armrest of the Magnum and Magnum CVX models. In addition, to complete automation of all the tractor's key functions, including the sequencing of up to 30 headland functions, the AFS screen also keeps track of the work done, fuel consumption, operating costs and much more. Here are just a few examples:

#### KEY FEATURES INCLUDE:

- Performance monitoring: record overall performance, performance for each day and performance for each job. All data from the AFS monitors can be saved to a USB stick for analysis back at the office if required.
- Vehicle settings: a series of AFS screens allow you to fine-tune the tractor's settings. It is easy to set the flow rates and timers for each of the remote valves, giving you an excellent overview of the whole setup.
- Hitch notebook: this screen allows you to save the settings for each implement according to the working conditions. Next time you attach the plough, for example, you just need to open the notebook, choose the right set-up and away you go.
- Full ISOBUS compatibility: hook up any compatible machine to display the user interface for the machine on the AFS monitor. Now you are able to operate the machine easily and interactively by pressing the control buttons on the AFS monitor screen. You do not need a separate control pendant or cables inside the cab.
- Video input: you can display a live video feed from a camera positioned at the rear end of a loader wagon or baler. This means you can monitor what is going on behind you without having to take your eyes off the work area in front of you.
- A variety of vehicle guidance solutions are available to match your needs for precision. A fully automated and integrated solution, which is factory installed, gives you the pinpoint accuracy you need for high value crops. Alternatively, a simple plug and play lightbar steering kit can be installed.



#### AFS PRO 700™ TOUCHSCREEN MONITOR

Enhanced vehicle control and additional productivity with programmable functions and settings, as well as notebook and ISOBUS compatibility.



# SAVE PRECIOUS TIME AND MONEY ON SERVICE

## KEEP DRIVING!

When there's a busy day ahead of you, the last thing you want is to waste time on servicing your tractor. When you run a Magnum tractor, daily checks and regular maintenance are easy and quick. For example, the radiator package is easy to clean and the air filter is conveniently located for quick inspection. Just make your quick checks and drive off!

## MAXIMUM UPTIME, MINIMUM SERVICE COSTS

The Magnum with Efficient Power technology keeps you working, reducing maintenance and costly downtime to a minimum. The long 600 hour service intervals are just one of the many features that drive down your maintenance and service costs.



### CONVENIENT ACCESS

New steps and handrails on right hand side for stability when accessing windows, mirrors and AFS receiver.



### QUICK AND EASY CLEANING

Radiators can be folded out for cleaning purposes.



### EASY ACCESS TO SERVICE POINTS

The one-piece engine bonnet is lifted by two gas-filled struts and can be set in two positions (45 and 90 degrees), even with a mounted front implement.



### EASY TO FILL UP

The fuel and AdBlue tank are accessible from ground level and the fuel-cap is lockable.





# SYSTEM SOLUTIONS

When you buy a Case IH machine, you can be sure not only that you're buying the best product, but also that you've got the best dealer back-up behind you. Case IH dealers can offer advice on selecting and financing the right machine, will ensure they deliver what you need when you need it, and will then continue to back you and your equipment with the service and spare parts supply you'd expect from a name as trusted as Case IH.



#### ALL THE PARTS AND SERVICE TO KEEP YOUR EQUIPMENT RUNNING

Find the full line of Case IH parts and components at your local dealer, plus full service maintenance programmes and industry leading warranties. It's expertise applied by skilled, factory-trained service professionals committed to providing you maximum uptime, season after season.



#### AROUND THE CLOCK. AROUND THE COUNTRY

Case IH Max Service is a customer support service that provides 24-hour, seven-day-a-week access to the people, products and parts support needed to keep your operation running during the times most critical to your profitability. Max Service backs up your dealer with every resource available to Case IH, to help maximise uptime and productivity of Case IH equipment and increase your return on investment through access to product experts and 24/7 emergency breakdown assistance.



#### AN OPTIMAL FINANCING SOLUTION FOR EVERY INVESTMENT

CNH Industrial Capital is the financing company for Case IH. Our employees are financial experts and have many years of experience in agriculture. We do not only know about Case IH products and the market, we also understand the individual requirements of your operations. Therefore we are always able to offer you a financial solution for your new investments that is tailored specifically to your operational requirements and respective machine usage in the form of loans, rent or leasing. Our most important goal is improving the profitability of your investments! Therefore you can combine every CNH Industrial Capital Financing with Capital accident and breakdown cover, as machine breakdown or repair insurance, in order to exclude risks to your investment and ensure greater planning reliability.



VISIT OUR FANSHOP AT  
**WWW.CASEIH.COM**

MODELS	MAGNUM 250	MAGNUM 280	MAGNUM 310 MAGNUM 310 ROWTRAC	MAGNUM 340 MAGNUM 340 ROWTRAC
<b>ENGINE</b>	FPT	FPT	FPT	FPT
Number of cylinders	6	6	6	6
Type	Common Rail Diesel engine with 24 valves, turbocharged and intercooled			
Emission level	EURO IV			
Capacity (cm <sup>3</sup> )	8,700	8,700	8,700	8,700
Maximum power ECE R120 <sup>3)</sup> Power Management <sup>4)</sup> (kW/hp(CV))	235 / 320	258 / 351	281 / 382	301 / 409
Maximum power ECE R120 <sup>3)</sup> (kW/hp(CV))	209 / 284	232 / 315	255 / 347	275 / 374
... at engine speed (rpm)	1,800	1,800	1,800	1,800
Rated power ECE R120 <sup>3)</sup> Power Management <sup>4)</sup> (kW/hp(CV))	210 / 286	232 / 315	255 / 347	276 / 375
Rated power ECE R120 <sup>3)</sup> (kW/hp(CV))	184 / 250	206 / 280	229 / 311	250 / 340
... at engine speed (rpm)	2,000	2,000	2,000	2,000
Maximum torque Power Management <sup>4)</sup> (Nm @ 1,400-1,600 rpm)	1,407	1,558	1,708	1,800
Maximum torque (Nm @ 1,500-1,600 rpm)	1,229	1,381	1,531	1,671
Torque rise Standard / Power Management <sup>4)</sup> (%)	40 / 40	40 / 41	40 / 40	40 / 37
Fuel tank capacity diesel / urea (litres)	678 / 99	678 / 99	678 / 99	678 / 99
<b>TRANSMISSION</b>				
19x4 Fullpowershift 50 kph	●	●	●	●
23x6 Fullpowershift with creeper 40 kph	○	○	○	○
Powershuttle	●	●	●	●
Rear axle diff-lock type	Electro-hydraulic with Auto control			
Service brake	Hydraulically operated multiple wet disc brake, self adjusting			
<b>POWER TAKE OFF</b>				
Engagement type	Electro-hydraulic			
Speeds Standard (Option)	1,000 ( 540/1,000)			
Engine speeds Standard (Option) (rpm)	1,803 ( 1,592/1,803)			
Shaft type Standard (Option)	1 3/4" 20 splines (1 3/8" 6 splines (540 rpm) or 1 3/8" 21 splines (1,000 rpm) or 1 3/4" 20 splines (1,000 rpm))			
<b>FRONT HITCH AND PTO</b>				
Front PTO 1,000 Speed @ 1,804 rpm	○	○	○	○
Front hitch lift capacity (kg)	5,000	5,000	5,000	5,000
<b>FOUR-WHEEL DRIVE AND STEERING (DRIVELINE)</b>				
Front axle category Standard / Option	Cat. 4.75 (-)	Cat. 4.75 (Cat. 5)	Cat. 4.75 (Cat. 5)	Cat. 5 (-)
Front axle suspension	○	○	○	○
Steering angle (°)	55	55	55	55
Min. turning radius <sup>1)</sup> track setting 1,800 mm (m)	4.8	5.3	5.3	5.3
<b>HYDRAULIC SYSTEM</b>				
System type	Variable displacement, pressure flow compensated pump			
Max. pump flow rate Standard / High Flow / Twin Flow (l/min)	166 / 221 / 282	166 / 221 / 282	166 / 221 / 282	166 / 221 / 282
System pressure (bar)	210	210	210	210
Control type	Electronic Hitch Control (EHC) with hitch ride control, hydraulic top link, automatic stabilizers optional			
Max. lift capacity (kg)	8,843	8,843	9,705	10,927
OECD lift capacity through range @ 610 mm (kg)	7,934	7,934	8,709	10,024
Max. number of rear remote valves	4 electronic remote valves standard, 5th and 6th optional - power beyond or low pressure return connection with individual remote valve timer and flow controls			
Remote valve timer control	0 - 30 seconds on all models			
Category type	Cat. III	Cat. III	Cat. III	Cat. IVN
Slip control	●	●	●	●

\* To comply with legislation and specification in your country

<sup>1)</sup> With standard tyres

<sup>2)</sup> Other tyres on request

<sup>3)</sup> ECE R120 correspond to ISO 14396 and 97/68/EC

<sup>4)</sup> Power Management is only available during mobile PTO and haulage applications

● Standard ○ Optional

MODELS	MAGNUM 250 CVX	MAGNUM 280 CVX	MAGNUM 310 CVX MAGNUM 310 ROWTRAC CVX	MAGNUM 340 CVX MAGNUM 340 ROWTRAC CVX	MAGNUM 380 CVX MAGNUM 380 ROWTRAC CVX
<b>ENGINE</b>	FPT	FPT	FPT	FPT	FPT
Number of cylinders	6	6	6	6	6
Type	Common Rail Diesel engine with 24 valves, turbocharged and intercooled				
Emission level	EURO IV				
Capacity (cm <sup>3</sup> )	8,700	8,700	8,700	8,700	8,700
Maximum power ECE R120 <sup>3)</sup> Power Management <sup>4)</sup> (kW/hp(CV))	235 / 320	258 / 351	281 / 382	301 / 409	320 / 435
Maximum power ECE R120 <sup>3)</sup> (kW/hp(CV))	209 / 284	232 / 315	255 / 347	275 / 374	307 / 417
... at engine speed (rpm)	1,800	1,800	1,800	1,800	1,800
Rated power ECE R120 <sup>3)</sup> Power Management <sup>4)</sup> (kW/hp(CV))	210 / 286	232 / 315	255 / 347	276 / 375	305 / 415
Rated power ECE R120 <sup>3)</sup> (kW/hp(CV))	184 / 250	206 / 280	229 / 311	250 / 340	279 / 379
... at engine speed (rpm)	2,000	2,000	2,000	2,000	2,000
Maximum torque Power Management <sup>4)</sup> (Nm @ 1,400-1,600 rpm)	1,407	1,558	1,708	1,800	1,850
Maximum torque (Nm @ 1,500-1,600 rpm)	1,229	1,381	1,531	1,671	1,850
Torque rise Standard / Power Management <sup>4)</sup> (%)	40 / 40	40 / 41	40 / 40	40 / 37	39 / 27
Fuel tank capacity diesel / urea (litres)	617 / 99	617 / 99	617 / 99	617 / 99	617 / 99
<b>TRANSMISSION</b>					
Continuously variable transmission 50 kph	•	•	•	•	•
Powershuttle	•	•	•	•	•
Rear axle diff-lock type	Electro-hydraulic with Auto control				
Service brake	Hydraulically operated multiple wet disc brake, self adjusting				
<b>POWER TAKE OFF</b>					
Engagement type	Electro-hydraulic				
Speeds Standard (Option)	1,000 ( 540/1,000)				
Engine speeds Standard (Option) (rpm)	1,803 ( 1,592/1,803)				
Shaft type Standard (Option)	1 3/4" 20 splines (1 3/8" 6 splines (540 rpm) or 1 3/8" 21 splines (1,000 rpm) or 1 3/4" 20 splines (1,000 rpm))				
<b>FRONT HITCH AND PTO</b>					
Front PTO 1,000 Speed @ 1,804 rpm	○	○	○	○	○
Front hitch lift capacity (kg)	5,000	5,000	5,000	5,000	5,000
<b>FOUR-WHEEL DRIVE AND STEERING (DRIVELINE)</b>					
Front axle category Standard / Option	Cat. 4.75 (-)	Cat. 4.75 (Cat. 5)	Cat. 4.75 (Cat. 5)	Cat. 5 (-)	
Front axle suspension	•	•	•	•	•
Steering angle (°)	55	55	55	55	55
Min. turning radius <sup>1)</sup> track setting 1,800 mm (m)	4.8	5.3	5.3	5.3	5.3
<b>HYDRAULIC SYSTEM</b>					
System type	Variable displacement, pressure flow compensated pump				
Max. pump flow rate Standard / High Flow / Twin Flow (l/min)	166 / 221 / 282	166 / 221 / 282	- / 221 / 282	- / 221 / 282	- / 221 / 282
System pressure (bar)	210	210			210
Control type	EElectronic Hitch Control (EHC) with hitch ride control, hydraulic top link, automatic stabilizers optional				
Max. lift capacity (kg)	8,843	8,843	9,705	10,927	10,927
OECD lift capacity through range @ 610 mm (kg)	7,934	7,934	8,709	10,024	10,024
Max. number of rear remote valves (Optional)	4 electronic remote valves standard, 5th and 6th optional - power beyond or low pressure return connection with individual remote valve timer and flow controls				
Remote valve timer control	0 - 30 seconds on all models				
Category type	Cat. III	Cat. III	Cat. III	Cat. IVN	Cat. IVN
Slip control	•	•	•	•	•

\* To comply with legislation and specification in your country

<sup>1)</sup> With standard tyres

<sup>2)</sup> Other tyres on request

<sup>3)</sup> ECE R120 correspond to ISO 14396 and 97/68/EC

<sup>4)</sup> Power Management is only available during mobile PTO and haulage applications

• Standard ○ Optional

MODELS	MAGNUM 250	MAGNUM 280	MAGNUM 310	MAGNUM 340
<b>WEIGHT</b>				
Approximate shipping weight standard / suspended front axle (kg)	10,830 / 11,290	10,910 / 11,415	10,910 / 11,415	11,730 / 12,190
Class 5 (option) / Class 5 suspended front axle (kg)	- / -	10,985 / 11,450	10,985 / 11,450	- / -
Magnum 340 with Heavy Duty Rear Axle (kg)	- / -	- / -	- / -	12,395 / 12,850
Permissible total weight Class 4.75 / Class 5 front axle (kg)	17,530 / -	17,530 / 17,850	17,530 / 17,850	- / 18,000
Max. permissible weight front Class 4.75 / Class 5 front axle (kg)	6,030 / -	6,030 / 6,350	6,030 / 6,350	- / 7,760
Max. permissible weight rear (kg)	11,500	11,500	11,500	11,500
<b>DIMENSIONS <sup>1)</sup></b>				
A: Total length only carrier / front hitch / front weights (mm)	6,015 / 6,295 / 6,225	6,015 / 6,295 / 6,225	6,015 / 6,295 / 6,225	6,015 / 6,295 / 6,225
with Heavy Duty rear axle	- / - / -	- / - / -	- / - / -	6,299 / 6,575 / 6,505
B: Total height (mm)	3,105	3,375	3,375	3,375
C: Total width (across rear fenders extension) (mm)	2,550	2,550	2,550	2,550
D: Wheel base standard / heavy duty rear axle (mm)	3,105 / -	3,105 / -	3,105 / -	3,105 / 3,155
E: Height at centre of rear axle to highest point (mm)	2,488	2,488	2,488	2,488
F: Track setting front (mm)	1,560 - 2,256	1,560 - 2,256	1,560 - 2,256	1,560 - 2,256
rear (mm)	1,470 - 2,294	1,470 - 2,294	1,470 - 2,294	1,470 - 2,294
<b>STANDARD TYRES <sup>2)</sup></b>				
Front	600 / 70 R30	600 / 70 R30	600 / 70 R30	600 / 70 R30
Rear	710 / 70 R42	710 / 70 R42	710 / 70 R42	710 / 70 R42

MODELS	MAGNUM 250 CVX	MAGNUM 280 CVX	MAGNUM 310 CVX	MAGNUM 340 CXV	MAGNUM 380 CVX
<b>WEIGHT</b>					
Approximate shipping weight std. / suspended front axle (kg)	10,830 / 11,290	10,910 / 11,415	10,910 / 11,415	11,730 / 12,190	12,395 / 12,850
Class 5 (option) / Class 5 suspended front axle (kg)	- / -	10,985 / 11,450	10,985 / 11,450	- / -	12,395 / 12,850
Magnum 340 with Heavy Duty Rear Axle (kg)	- / -	- / -	- / -	12,395 / 12,850	- / -
Permissible total weight Class 4.75 / Class 5 front axle (kg)	17,530 / -	17,530 / 17,850	17,530 / 17,850	- / 18,000	- / 18,000
Max. permissible weight front Class 4.75 / Class 5 front axle (kg)	6,030 / -	6,030 / 6,350	6,030 / 6,350	- / 7,760	- / 7,760
Max. permissible weight rear (kg)	11,500	11,500	11,500	11,500	11,500
<b>DIMENSIONS <sup>1)</sup></b>					
A: Total length only carrier / front hitch / front weights (mm)	6,015 / 6,295 / 6,225	6,015 / 6,295 / 6,225	6,015 / 6,295 / 6,225	6,015 / 6,295 / 6,225	6,299 / 6,575 / 6,505
with Heavy Duty rear axle	- / - / -	- / - / -	- / - / -	6,299 / 6,575 / 6,505	- / - / -
B: Total height (mm)	3,375	3,375	3,375	3,375	3,375
C: Total width (across rear fenders extension) (mm)	2,550	2,550	2,550	2,550	2,550
D: Wheel base standard / heavy duty rear axle (mm)	3,105 / -	3,105 / -	3,105 / -	3,105 / 3,155	- / 3,155
E: Height at centre of rear axle to highest point (mm)	2,488	2,488	2,488	2,488	2,488
F: Track setting front (mm)	1,560 - 2,256	1,560 - 2,256	1,560 - 2,256	1,560 - 2,256	1,560 - 2,256
rear (mm)	1,470 - 2,294	1,470 - 2,294	1,470 - 2,294	1,470 - 2,294	1,470 - 2,294
<b>STANDARD TYRES <sup>2)</sup></b>					
Front	600 / 70 R30	600 / 70 R30	600 / 70 R30	600 / 70 R30	IF620 / 75 R30
Rear	710 / 70 R42	710 / 70 R42	710 / 70 R42	710 / 70 R42	IF710 / 74 R42

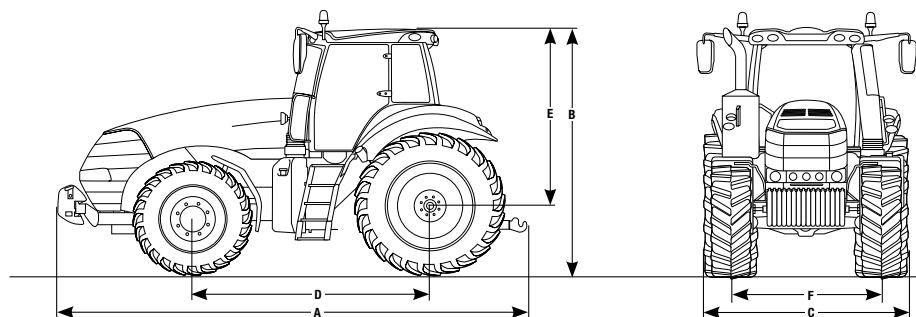



MODELS	MAGNUM 310 ROWTRAC	MAGNUM 340 ROWTRAC
<b>WEIGHT</b>		
Approximate shipping weight Class 5 / Class 5 suspended front axle (kg)	15,872 / 16,332	15,872 / 16,332
Permissible total weight Class 5 front axle (kg)	To comply with legislation and specification in your country	To comply with legislation and specification in your country
Max. permissible weight front Class 5 front axle (kg)	To comply with legislation and specification in your country	To comply with legislation and specification in your country
Max. permissible weight rear (kg)	To comply with legislation and specification in your country	To comply with legislation and specification in your country
<b>DIMENSIONS <sup>1)</sup></b>		
A: Total length only carrier / front hitch / front weights (mm)	6,015 / 6,295 / 6,225	6,015 / 6,295 / 6,225
B: Total height (mm)	3,450	3,450
C: Min./Max. width (across rear fenders extension) (mm)	2,540 (24"/76") / 3,810 (30"/120")	2,540 (24"/76") / 3,810 (30"/120")
D: Wheel base (mm)	3,155	3,155
E: Height to centre of drivewheel (mm)	1,243	1,243
F: Track setting front (mm)	1,560 - 2,256	1,560 - 2,256
rear (mm)	1,470 - 2,294	1,470 - 2,294
<b>STANDARD TYRES <sup>2)</sup></b>		
Front	620 / 75 R30	620 / 75 R30
<b>TRACK</b>		
Available track width	61 cm, 76.2 cm	61 cm, 76.2 cm
Available row spacing	193 cm, 203.2 cm and 223.5 cm	193 cm, 203.2 cm and 223.5 cm

MODELS	MAGNUM 310 ROWTRAC CVX	MAGNUM 340 ROWTRAC CVX	MAGNUM 380 ROWTRAC CVX
<b>WEIGHT</b>			
Approximate shipping weight Class 5 / Class 5 suspended front axle (kg)	16,653 / 17,113	16,653 / 17,113	16,653 / 17,113
Permissible total weight Class Class 5 front axle (kg)	To comply with legislation and specification in your country	To comply with legislation and specification in your country	To comply with legislation and specification in your country
Max. permissible weight front Class 5 front axle (kg)	To comply with legislation and specification in your country	To comply with legislation and specification in your country	To comply with legislation and specification in your country
Max. permissible weight rear (kg)	To comply with legislation and specification in your country	To comply with legislation and specification in your country	To comply with legislation and specification in your country
<b>DIMENSIONS <sup>1)</sup></b>			
A: Total length only carrier / front hitch / front weights (mm)	6,015 / 6,295 / 6,225	6,015 / 6,295 / 6,225	6,015 / 6,295 / 6,225
B: Total height (mm)	3,450	3,450	3,450
C: Min./Max. width (across rear fenders extension) (mm)	2,540 (24"/76") / 3,810 (30"/120")	2,540 (24"/76") / 3,810 (30"/120")	2,650
D: Wheel base (mm)	3,155	3,155	3,155
E: Height to centre of drivewheel (mm)	1,243	1,243	1,243
F: Track setting front (mm)	1,560 - 2,256	1,560 - 2,256	1,560 - 2,256
rear (mm)	1,470 - 2,294	1,470 - 2,294	1,470 - 2,294
<b>STANDARD TYRES <sup>2)</sup></b>			
Front	620 / 75 R30	620 / 75 R30	620 / 75 R30
<b>TRACK</b>			
Available track width	61 cm, 76.2 cm	61 cm, 76.2 cm	61 cm, 76.2 cm
Available row spacing	193 cm, 203.2 cm and 223.5 cm	193 cm, 203.2 cm and 223.5 cm	193 cm, 203.2 cm and 223.5 cm

 Safety never hurts! Always read the Operator's Manual before working with any equipment. Inspect equipment before using it, and be sure it is operating properly. Follow the product safety signs, and use any safety features provided. This literature has been published for worldwide circulation. The standard and optional equipment and the availability of individual models may vary from one country to the next. Case IH reserves the right to undertake modifications without prior notice to the design and technical equipment at all times without this resulting in any obligation whatsoever to make such modifications to units already sold. Whilst every effort is made to ensure that the specifications, descriptions and illustrations in this brochure are correct at the time of going to press, these are also subject to change without prior notice. Illustrations may show optional equipment or may not show all standard equipment. Case IH recommends **AKCELA** lubricants.

CNH Österreich GmbH, Steyrer Straße 32, 4300 Sankt Valentin, Austria  
 © 2015 CASE IH - [www.caseih.com](http://www.caseih.com) - Magnum Series INB BR - Free phone 00800 22 73 44 00 - Printed in Austria - 01/15 - Cod. 15C0002/INB

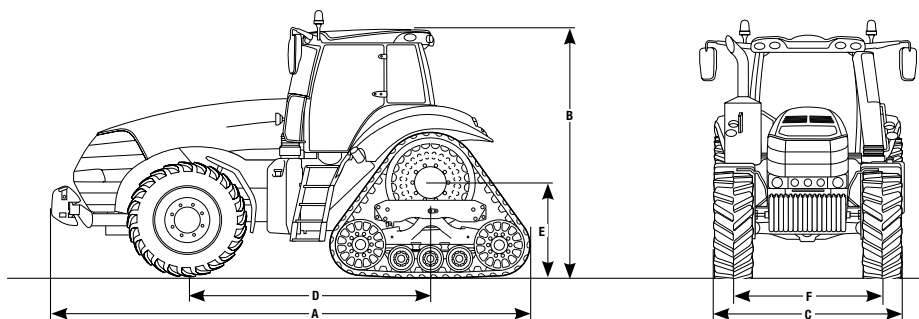



# RACINE HOME TO THE MAGNUM

The Case IH manufacturing plant in Racine, Wisconsin, USA, is the home of the Magnum tractor.

## IN THE BEGINNING...

Jerome Increase Case founded the Racine Threshing Machine Works in 1842 and in 1869 produced the first steam engine tractor, the Old No.1. From these early beginnings, Case IH has gone on to play a major role in shaping agriculture. As the inventor of the power take off and the pioneer of the continuously variable transmission, Case IH has continuously raised the bar on productivity and reliability in farming.

## THE HERITAGE LIVES ON

The 640,200 square feet (595,000 square metres) plant is home to the production of the Magnum range and manufactures components for other Case IH products, such as transmissions for the Axial-Flow Combines, Cotton Express Pickers, axles and valves, powershift and directional control valves for agricultural applications.

The Racine manufacturing operations, which employ 500 people, are run according to lean manufacturing principles that aim to maximise efficiency and quality while minimising waste. The state-of-the-art assembly line features ergonomic handling systems, wash and robotic paint systems and computerised diagnostic testing equipment to ensure the highest quality and reliability levels.



