



ENGINE

Model	F5BFL413D*C009
Emissions Certification	Tier 4 Final
Type	Diesel, Turbo – Direct Injection
Cylinders	4
Bore/Stroke	3.9 x 4.3 in (99 x 110 mm)
Displacement	207 in ³ (3.4 L)
Fuel injection	Direct
Fuel	#2 Diesel
Fuel filter:	
Pre-filter	Beta (30) = 200/spin-on
Main filter	Beta (4) = 20/spin-on
Air intake	Turbocharged w/ waste gate and external cooled EGR
Exhaust aftertreatment	Selective Catalytic Reduction – SCR
Cooling	Liquid
Engine speeds	RPM
High idle – no load	2,500 +/- 25
Rated – full load	2,500
Low idle	1,150 +/- 25
Horsepower @ 2,500 RPM – SAE J1349:	
Gross	90 hp (67 kW)
Net	84 hp (63 kW)
Peak torque @ 1,400 RPM	282 lb-ft (383 N-m)
Radiator:	
Core type	Aluminum bar and plate
Core size area	2.21 ft ² (.206 m ²)
Rows of tubes	21
Cap pressure	16 +/- 2 psi (1.10 +/- 0.14 bar)
Fan:	
Diameter	22 in (560 mm)
Ratio	0.96:1 standard, 1.1:1 high flow
Water pump:	
Style	Centrifugal
Flow	47.8 gpm (181 L/min)
Engine lubrication pump	Rotor pump w/ deep sump pan, plate cooler and pressurized under-piston nozzles
Pump operating angle ratings:	
Side to side	45°
Bucket up	35°
Bucket Down	45°

LIFT GEOMETRY

Radial Lift

DRIVETRAIN

Drive pump controls	Servo-assist mechanical
Pump to engine ratio	1:1
Displacement	2.81 in ³ (46 cm ³)
Flow @ rated engine RPM:	
@ 97% efficiency	29.4 gpm (111 L/min)
Charge pressure	360 psi (24.5 bar)
System relief pressure	5,220 psi (360 bar)

Drive pump controls	Electro-hydraulic
Pump to engine ratio	1:1
Displacement	2.75 in ³ (45 cm ³)
Flow @ rated engine RPM:	
@ 97% efficiency	28.8 gpm (109 L/min)
Charge pressure	362 psi (25 bar)
System relief pressure	5,220 psi (360 bar)

Drive motors:	
Max. displacement	28.7 in ³ (470 cm ³)
Displacement:	
High speed	17.2 in ³ (282 cm ³)
Motor RPM @ high idle and 97% efficiency:	
2-speed	355
Motor torque @ max. displacement and relief pressure, calculated @ 5,220 psi (360 bar):	1,987 lb-ft (2 694 N-m)

Travel speed:	
Low range	7 mph (11.3 kph)
High range	10.5 mph (16.9 kph)

Final drive	Single-reduction chain drive
-------------	------------------------------

Drive chain:	
Size	ASA #100
Tensile strength	30,000 lb (133.4 kN)

Axles:	
Torque @ max. displacement and relief pressure	5,957 lb-ft (8 077 N-m)
Diameter	2.44 in (62 mm)
Length	15.6 in (396 mm)

Parking brake:	
Type	Spring-applied, hydraulic release multiple disc.
Engagement	Depress on/off brake button on handle or instrument panel, raise seat bar, get off seat or stop engine.

ELECTRICAL

Alternator	160 amp
Starter	4.29 hp (3.2 kW)

Battery	12-volt low-maintenance 1,000 cold-cranking amps @ 0° F (-18° C°)
---------	--

OPERATOR ENVIRONMENT

ROPS/FOPS Level 1 canopy w/ side screens;
Keyed start ignition; Tilt ROPS/FOPS; Rear
window w/ emergency escape; Deluxe cloth, air
suspension seat, w/ 2 in (51 mm) retractable 3
point lap seat belt, w/ heater and lumbar support;
Hand and foot throttle; Alarm package – back-up

and horn; Rearview mirror; Headliner; Dome
light; Top window; Cup holder; 12V Power plug
socket; Foot rest; Seat pocket; Padded seat bar
w/ integral armrests; Loader control lockout
system; Electric parking brake control; Operator's
compartment floor cleanout; Proportional
auxiliary hydraulic control – on joystick; Advanced
instrument cluster w/ digital hour meter,
tachometer, fuel level LCD bar graph w/ alarm,
DEF Level, diagnostic features and security lockout.

Warning lights w/ alarms:
Engine coolant temperature; Engine oil pressure;
Engine malfunction; Hydraulic charge pressure;
Hydraulic filter restriction; Hydraulic oil
temperature; Critical system stop, Engine
system, Hydraulic system, Electrical and
diagnostic system.

Warning alarms:
Battery voltage – plus display; Diesel Exhaust
Fluid – DEF; Oil service.

Indicator light:
Engine preheat; Parking brake;
Seat bar reminder.

OPERATING WEIGHT

Unit equipped w/ open cab; 165 lb operator;	
72 in Low Profile bucket; full of fuel;	
12 x 16.5 tires:	8,117 lb (3 681 kg)
Shipping weight	7,773 lb (3 526 kg)

Add-on weights:	
Side cab glass	47 lb (21.3 kg)
Polycarbonate cab door	75 lb (34 kg)
Glass cab door w/ wiper	75 lb (34 kg)
Suspension seat	22 lb (10 kg)
Additional counterweight	300 lb (136 kg)

HYDRAULICS

Implement pump type	Gear
Displacement:	
Standard aux.	2.23 in ³ (36.6 cm ³)
High-flow aux.	1.24 in ³ (20.4 cm ³)

Standard flow @ rated engine RPM: @ 100% efficiency	24.2 gpm (91.5 L/min)
--	-----------------------

Optional high-flow @ rated engine RPM: @ 100% efficiency	37.6 gpm (142.5 L/min)
---	------------------------

Enhanced high-flow @ rated engine RPM: @ 100% efficiency	35 gpm (132.5 L/min)
---	----------------------

Loader control valve:	
Type	3 spool/open center/series – series
Relief pressure	3,046 psi (210 bar)

Port relief pressures:	
Loader raise	3,263 psi (225 bar)
Bucket curl	3,770 psi (260 bar)
Bucket dump	1,160 psi (80 bar)

Hydraulic lines:	
Tubing	37° JIC Flare
Loop hoses	SAE 100 R19

HYDRAULICS CONT.

Hydraulic oil cooler:	
Number of fins	10 per in (3.94 per cm)
Number of tube rows × columns	9 bar/plate
Area	138.7 in ² (890 cm ²)

Hydraulic filter	Beta (4) = 75/spin-on
------------------	-----------------------

Lift cylinders:	
Bore diameter	2.75 in (69.85 mm)
Rod diameter	2 in (50.8 mm)
Stroke	33.4 in (847.9 mm)
Closed length	47.1 in (1 196 mm)

Bucket cylinders:	
Bore diameter	3 in (76.2 mm)
Rod diameter	1.5 in (38.1 mm)
Stroke	16.4 in (410 mm)
Closed length	24 in (610 mm)

SERVICE CAPACITIES

Fuel tank	25.5 gal (96.5 L)
Engine oil w/ filter	8.9 qt (8.5 L)

Hydraulic system:	
Reservoir	6.0 gal (22.7 L)
Total	11.9 gal (45.4 L)

Chain tanks – per side	5.9 gal (22.2 L)
Diesel Exhaust Fluid (DEF) Tank	2.8 gal (10.7 L)

PERFORMANCE SPECS

Rated operating capacity – ROC*:	
50% of tipping load	2,700 lb (1 225 kg)
w/ additional counterweight	2,800 lb (1 270 kg)

Tipping load*	5,400 lb (2 450 kg)
---------------	---------------------

Breakout forces @ 3,150 psi (217 bar)*:	
Bucket cylinders	8,677 lb (38.6 kN)
Lift cylinders – tip limit	6,096 lb (27.1 kN)

Cycle times:	
Raise	3.6 sec
Lower	2 sec
Dump	2.6 sec
Roll back	2 sec

NOTE: *Measured using 72 in (1.83 m) dirt and foundry bucket.

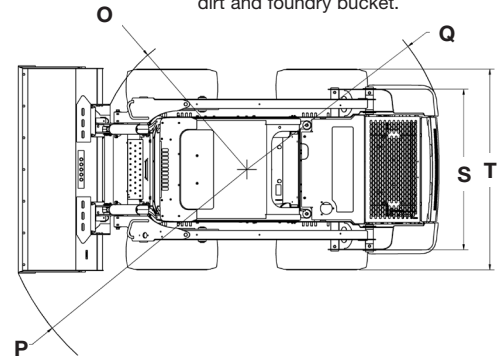
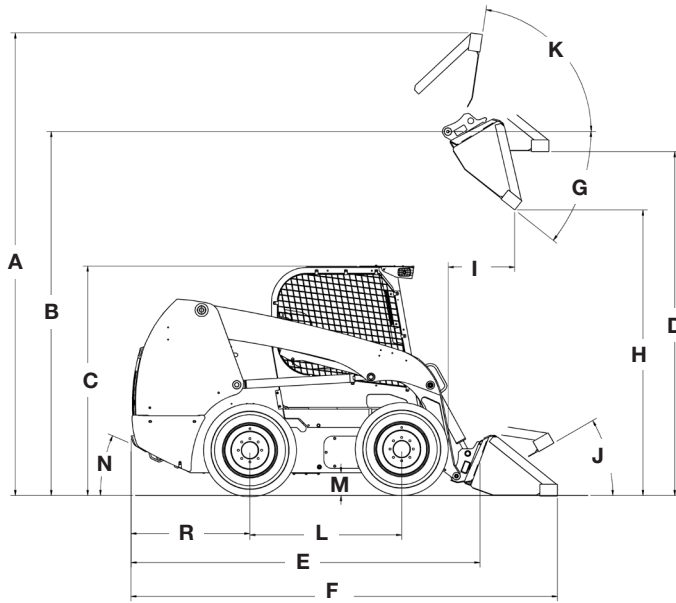

Line drawings are for illustrative purpose only and may not be exact representation of unit.

DIMENSIONS

A. Overall operating height:		
w/ foundry/excavating bucket		156.3 in (3.97 m)
w/ low profile bucket		160.3 in (4.07 m)
w/ low profile extended bucket		165.3 in (4.2 m)
Height to:		
B. Bucket hinge pin		125.1 in (3.18 m)
C. Top of ROPS		78.8 in (2 m)
D. Bottom of level bucket, fully raised		118.2 in (3 m)
Overall length:		
E. w/o attachment w/ coupler		118.7 in (3.01 m)
F. w/ foundry/excavating bucket on ground		143.9 in (3.66 m)
w/ low profile bucket		148 in (3.76 m)
w/ low profile extended bucket		153 in (3.89 m)
G. Maximum dump angle		38.1°
H. Dump height:		
w/ foundry/excavating bucket		100.9 in (2.56 m) @ 38.1°
w/ low profile bucket		98.3 in (2.50 m) @ 38.1°
I. Dump reach at maximum height w/ low profile bucket		22.2 in (.56 m) @ 38.1°
Maximum attachment rollback:		
J. Bucket on ground		30.8°
K. Bucket at full height		99.8°
L. Wheelbase		52 in (1.32 m)
M. Ground clearance – bottom of belly pan		8 in (.2 m)
N. Angle of departure		23.5°
Clearance circle:		
O. w/o bucket		53.7 in (1.37 m)
P. w/ 72 in (1.83 m) foundry/excavating bucket in carry position		83.5 in (2.12 m)
w/ 72 in (1.83 m) low profile bucket on ground		87.2 in (2.22 m)
w/ 72 in (1.83 m) extended low profile on ground		91.9 in (2.33 m)
Q. Clearance circle rear		71.2 in (1.81 m)
R. Rear axle to bumper		42.4 in (1.08 m)
S. Tread over gauge w/ spec tires		56.9 in (1.45 m)
T. Over the tire width spec tires		69.8 in (1.77 m)

OPTIONAL BUCKETS

Type	Width	Weight	Heaped Capacity
Dirt and Foundry	72 in (1.83 m)	420 lb (190 kg)	16.2 ft ³ (.46 m ³)
	78 in (1.98 m)	440 lb (200 kg)	17.7 ft ³ (.5 m ³)
Low Profile	72 in (1.83 m)	480 lb (218 kg)	14.8 ft ³ (.42 m ³)
Low Profile Extended	72 in (1.83 m)	510 lb (232 kg)	17.7 ft ³ (.5 m ³)
	78 in (1.98 m)	540 lb (245 kg)	19.1 ft ³ (54 m ³)
	84 in (2.13 m)	575 lb (262 kg)	20.5 ft ³ (58 m ³)
Light Material	72 in (1.83 m)	475 lb (216 kg)	23.3 ft ³ (66 m ³)
	84 in (2.13 m)	540 lb (245 kg)	27.5 ft ³ (78 m ³)
Manure and Slurry	72 in (1.83 m)	480 lb (218 kg)	19.1 ft ³ (54 m ³)
Heavy-Duty	72 in (1.83 m)	510 lb (230 kg)	14.1 ft ³ (40 m ³)
	78 in (1.98 m)	530 lb (240 kg)	15.5 ft ³ (44 m ³)
	84 in (2.13 m)	550 lb (250 kg)	17 ft ³ (48 m ³)
Heavy-Duty Extended w/ SmartFit™ Bucket Teeth	72 in (1.83 m)	667 lb (303 kg)	17.4 ft ³ (49 m ³)
	78 in (1.98 m)	697 lb (316 kg)	18.9 ft ³ (54 m ³)
	84 in (2.13 m)	728 lb (330 kg)	20.5 ft ³ (58 m ³)

STANDARD EQUIPMENT

OPERATOR ENVIRONMENT

See page 1

ENGINE

F5BFL413D* C009
207 CID (3.4 L) Turbo
Tier 4 Final Certified
Diesel Oxidation Catalyst (DOC) w/
Selective Catalytic Reduction
(SCR) muffler
Charged Air Cooler (CAC)
High Pressure Common Rail (HPCR)
fuel injection
Horsepower:
Gross: 90 hp (67 kW)
Net: 84 hp (63 kW)
Peak torque: 282 lb-ft (383 N·m)
160 amp alternator
Dual element air cooler
Organic Acid Technology (OAT)
Anti-freeze solution to -34° F
Fuel tank – 25.5 gal (U.S.)
Over and under radiator and oil cooler
3-stack after cooler/radiator/oil
cooler configuration
Glow plugs

OPTIONAL EQUIPMENT

OPERATOR ENVIRONMENT

Enclosed cab:
Fully sealed and pressurized – FSP
Glass door w/ wiper and washer
Sliding side windows – removable
Heater and air conditioner
AM/FM Bluetooth® radio w/ 2 speakers
Keyless start ignition
8 in Color LCD display
Economy mode (auto idle shutdown)
Auto engine protection shutdown
3-point seat belt
Electro-hydraulic controls:
For drive/steering, loader functions
Switchable between H and ISO patterns
Adjustable sensitivity of controls
Mechanical hand controls
Hand and foot controls:
Hand controls the loader drive function
and foot controls the bucket and boom
Suspension seat, vinyl
Demolition cab door w/ polycarbonate

Integral engine oil cooler
Fuel filter w/ water trap
1,000 CCA 12V battery
Master electrical disconnect
Jump start terminal

DRIVETRAIN

2-speed hydrostatic four wheel drive
ASA #100HS drive chain
SAHR disc parking brake

HYDRAULICS

Auxiliary hydraulics:
@ 3,050 psi (210 bar) – 24.2 gpm
(91.5 L/min)
6 micron oil filtration system
3-spool loader control valve
Auxiliary hydraulic disconnects, ISO
flat-face – connect-under-pressure
w/ case drain
Hydraulic circuit pedal lock
Auxiliary function lockout override
Loader lift lockout override
Heavy-duty hydraulic oil cooler
Loader arm float position
Loader function lockout system

Ignition timeout
Machine settings user access levels
Operator security codes
Auto idle setting

HYDRAULICS

High-flow auxiliary hydraulics – combined:
@ 3,050 psi (210 bar) – 37.6 gpm
(142.5 L/min)
Enhanced high-flow auxiliary hydraulics:
@ 4,000 psi (276 bar) – 35 gpm
(132.5 L/min)
Second auxiliary hydraulics
Hydraulic one-way self-leveling
Ride control

LOADER

Hydraulic attachment coupler

DRIVETRAIN

Creep speed mode (for EH machines only)

LOADER

Auxiliary front electric control
Heavy duty hydraulic attachment coupler
Radial lift geometry
Loader lift arm support strut

TIRES

12 × 16.5 Heav-duty

OTHER STANDARD FEATURES

LED lights – 2 front, 2 side, 2 rear flood
Pre-wired for rotating beacon
Lockable service access hood
Single-point daily service
Rear tail lights
Remote oil and fuel filters
Block heater
Debris ingress sealing
Mounting points for add-on counterweights

TELEMATICS

MyCASEConstruction Telematics – Includes
hardware and 7-Year data subscription
SiteConnect module providing remote
diagnostics capability

OTHER

Language decals
Buckets – see page 3
Bolt-on bucket cutting edges
Special paint
Offsite service arrangement

FACTORY SUPPLIED ATTACHMENTS

Add-on counterweights
Road lights
Rotating beacon
Four-corner LED strobe

SERVICE PARTS

3 in (76.2 mm) retractable seat belt
Bolt-on heavy-duty bucket teeth

CaseCE.com

©2026 CNH Industrial America LLC. All rights reserved. CASE is a trademark registered in the United States and many other countries, owned by or licensed to CNH Industrial N.V., its subsidiaries or affiliates. CNH Industrial Capital is a trademark in the United States and many other countries, owned by or licensed to CNH Industrial N.V., its subsidiaries or affiliates. Printed in U.S.A. Contains 10% post-consumer fiber.

IMPORTANT: CASE Construction Equipment Inc. reserves the right to change these specifications without notice and without incurring any obligation relating to such change. Availability of some models and equipment builds vary according to the country in which the equipment is used. The illustrations and text may include optional equipment and accessories and may not include all standard equipment. Your CASE dealer/distributor will be able to give you details of the products and their specifications available in your area.



CASE Construction Equipment is biodiesel-friendly. NOTE: All engines meet current EPA emissions regulations. All specifications are stated in accordance with SAE Standards or Recommended Practices, where applicable.



Always read the Operator's Manual before operating any equipment. Inspect equipment before using it, and be sure it is operating properly. Follow the product safety signs and use any safety features provided.

Form No. CCE202605SR270B

Replaces Form No. CCE202310SR270B

SR270B

4 of 4