

Hydraulic quick coupling system

⚠ WARNING

Crushing hazard!

Never put your hands inside the quick coupler when the engine is running. Turn off the engine and wait for all movement to stop.

Failure to comply could result in death or serious injury.

W0252A

⚠ WARNING

Hazard to bystanders!

ALWAYS make sure the work area is clear of bystanders and domestic animals before starting this procedure. Know the full area of movement of the machine. Do not permit anyone to enter the area of movement during this procedure.

Failure to comply could result in death or serious injury.

W0245A

NOTICE: The CASE CONSTRUCTION quick coupling system is supplied by the high pressure hydraulic system of the machine. Refer to Chapter 8 for the maximum working pressure of the hydraulic system. Make sure to use a quick coupler that is suitable for proper and safe operation with high pressure hydraulics. For information consult the CASE CONSTRUCTION dealer.

NOTICE: Make sure to read and understand the Operator's Manual of the hydraulic quick coupler for proper installation, usage and maintenance.

NOTICE: The quick coupler extends the length of the arm. Make sure to check the operating range of the coupled attachment in order to avoid risk of hitting the cab or the machine frame.

NOTICE: Never operate with a quick coupled hydraulic breaker over a long period of time, in order to reduce the risk of premature wear, failures or breakage of the quick coupler. Never use the breaker as a lever, as the stress would be borne by the quick coupler cylinder.

Attachment engagement

To perform the attachment engagement, CASE CONSTRUCTION recommends to set the engine speed throttle to level 8.

1. Make sure the attachment to be installed is laying safely on flat and level ground.
2. Slide the lock device and press the back side of the quick coupler switch (1) to set the unlocking status of the quick coupling system. The audible alarm device starts sounding.
3. Operate the arm and bucket controls so that the arm is practically vertical, sloping slightly towards the cab to release the safety device. Extend the bucket cylinder rod completely and maintain the hydraulic pressure for approximately 5 – 10 s so that the latching hook retracts.

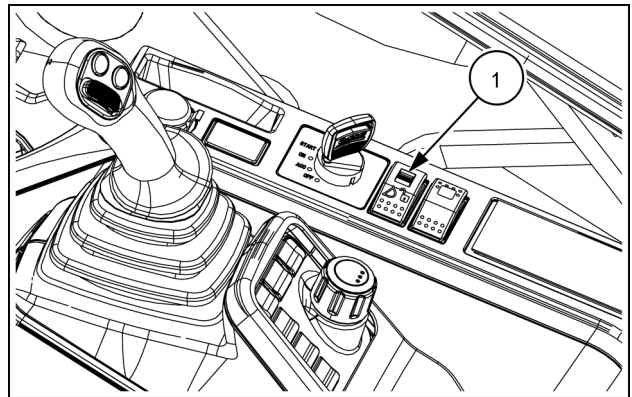

SMIL21CEX5000AA 1

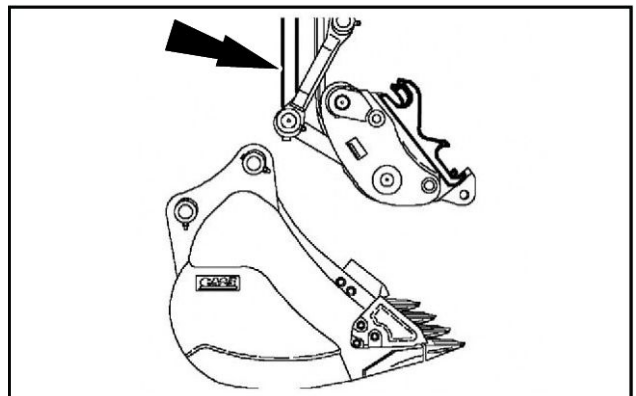

SMIL13CEX2697AB 2

4. Operate the arm and bucket controls so as to bring the quick coupler hook (2) around the attachment pin (3).

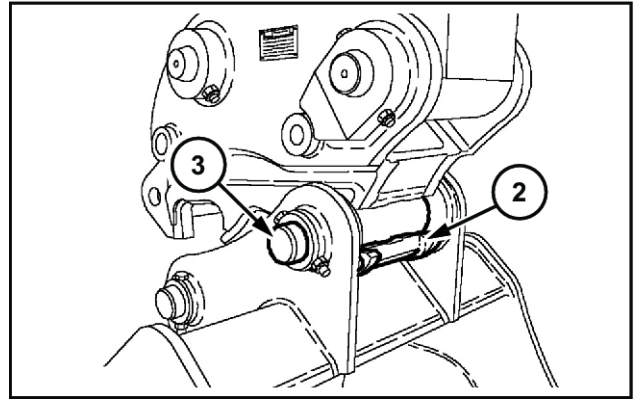

SML13CEX2698AB 3

5. Operate the bucket control lever so that the pin is completely engaged in the quick coupler hook.

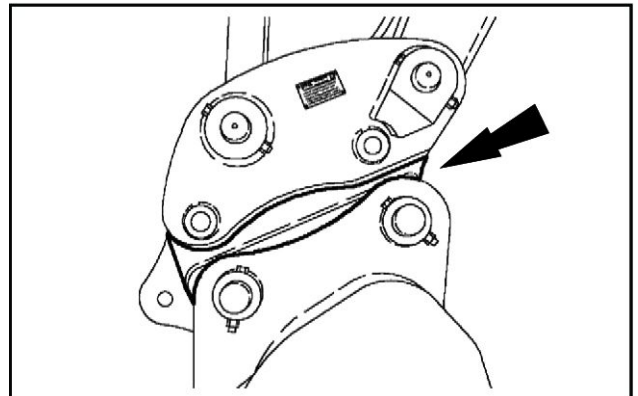

SML13CEX2699AB 4

6. Operate the arm control to raise the arm and operate the bucket control to extend the bucket cylinder rod completely.

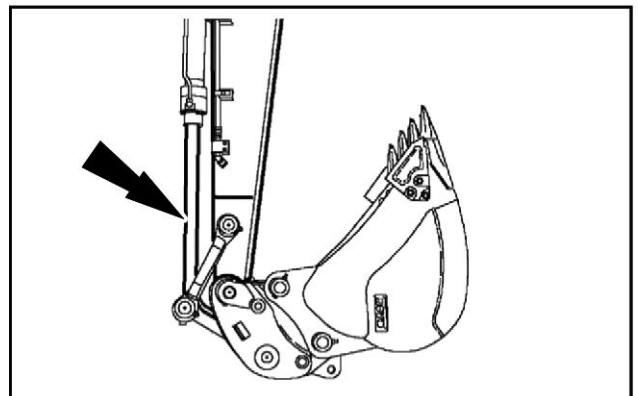

SML13CEX2700AB 5

7. Raise the arm until the attachment pin is visible from the operator's seat.

NOTICE: The quick coupler extends the length of the arm and with certain attachments there is the risk to hit the cab in some operating positions. With this kind of attachments, it may not be possible to raise the arm until the attachment pin is visible from the operator's seat.

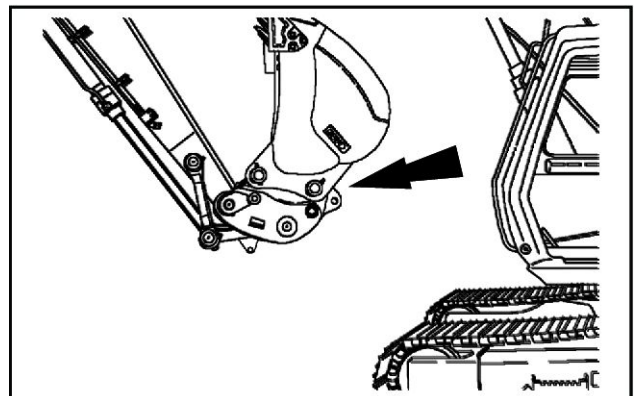

SML13CEX2701AB 6

8. Press the front side of the quick coupler switch (1) to set the locking status of the quick coupling system. The audible alarm device stops sounding.

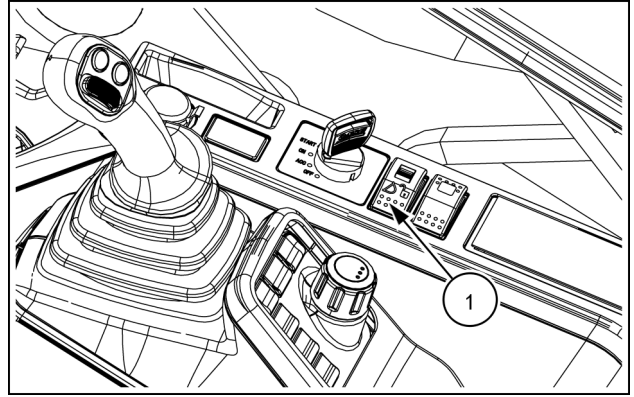

SMIL21CEX5000AA 7

9. Maintain the hydraulic pressure in the bucket cylinder for approximately **5 – 10 s** to allow the latching hook to close.
10. Confirm that the attachment pin is correctly engaged in the latching hook.

NOTE: the latching hook has a different color to ease the visual confirmation of the engagement of the pin.

NOTICE: If visual confirmation is not possible from the operator's seat, get down from the machine and make sure that the attachment pin is correctly engaged in the latching hook.

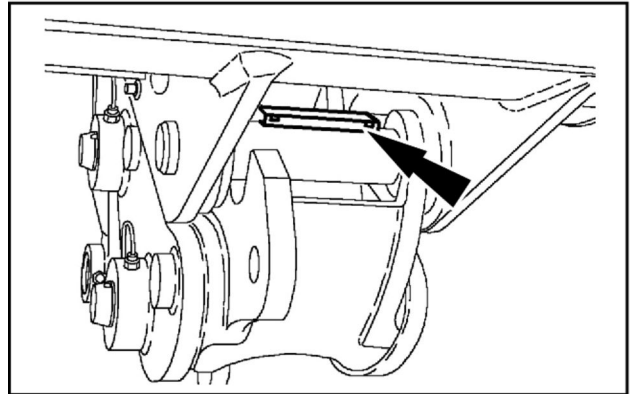

SMIL13CEX2702AB 8

11. Operate the bucket control to retract the cylinder rod and allow the safety device to engage.
12. To ensure that the bucket/attachment pins are securely held by the quick coupler, apply force to the bucket/attachment by pressing it against the ground.

NOTE: This operation is commonly known as “Bump Test” or “Ground test”.

NOTICE: If the quick coupler is used in conjunction with an hydraulic breaker, do not apply force with the chisel.

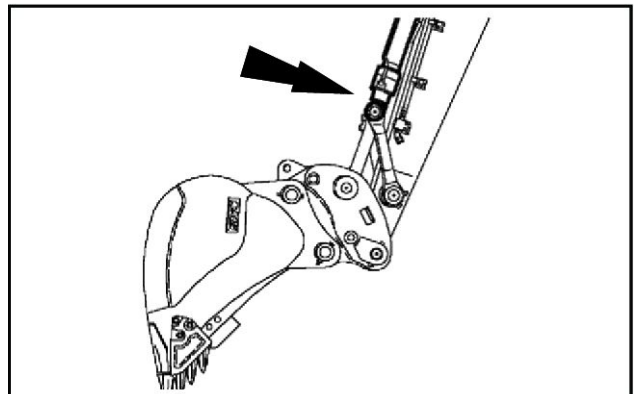

SMIL13CEX2703AB 9

Attachment disengagement

To perform the attachment disengagement, CASE CONSTRUCTION recommends to set the engine speed throttle to level 8.

1. Operate the arm and bucket controls so that the arm is practically vertical, sloping slightly towards the cab, to release the safety device.
2. Slide the lock device and press the back side of the quick coupler switch **(1)** to set the unlocking status of the quick coupling system. The audible alarm device starts sounding.
3. Extend the bucket cylinder rod completely and maintain the hydraulic pressure for approximately **5 – 10 s** so that the latching hook retracts.
4. Operate the bucket and arm controls to lay the attachment safely on flat, level ground.
5. Operate the arm control to unhook the attachment.
6. Press the front side of the quick coupler switch **(1)** to set the locking status of the quick coupling system. The audible alarm device stops sounding.

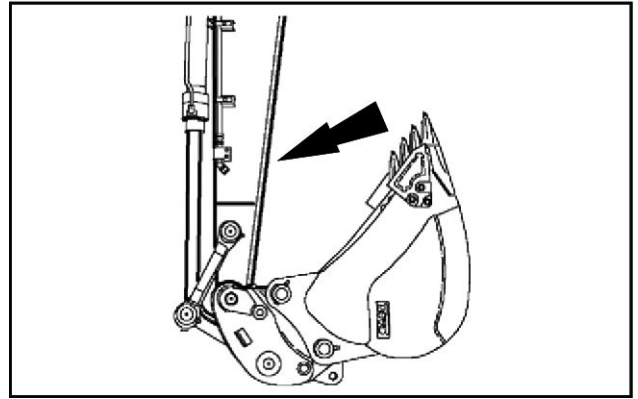

SMIL13CEX2704AB 10

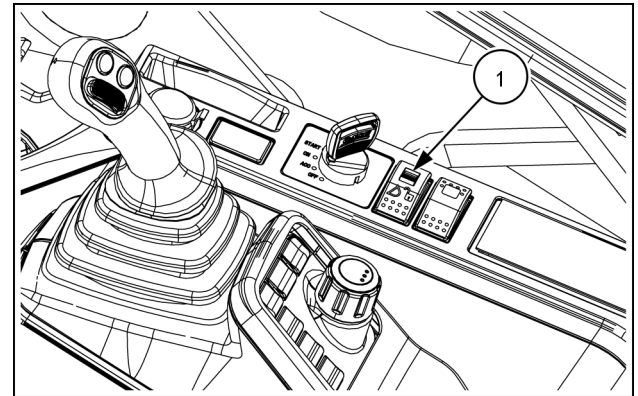

SMIL21CEX5000AA 11

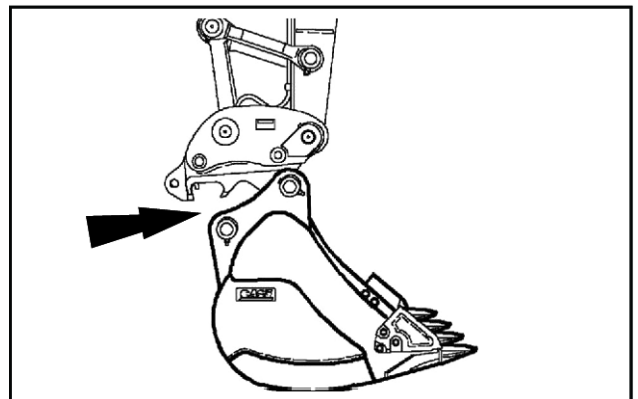

SMIL13CEX2705AB 12

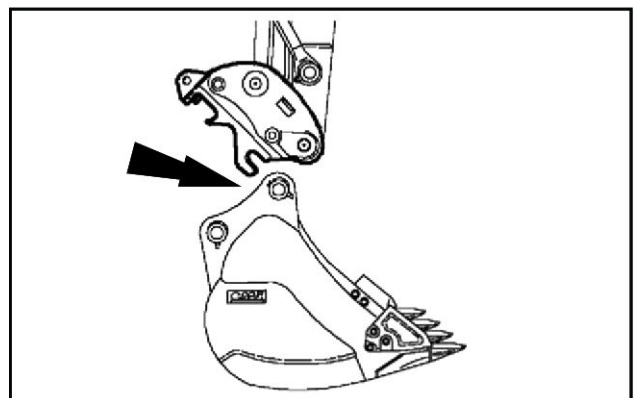

SMIL13CEX2706AB 13