

CONTROL LEVERS



Control lever switch configurations

The following functions can be activated from the control handles depending on your machine's configuration.

- Horn — Squeeze the trigger to sound the horn.
- Park — Press the park button to activate or deactivate the parking brake. The park symbol on the instrument panel will illuminate red when the parking brake is on.

NOTE: The park brake button on the right-hand control lever will not turn off the park brake until the operator presses the "PUSH TO OPERATE" button.

NOTE: The other hydraulic functions remain active when the parking brake is ON.

- Proportional auxiliary with detent— Operate the auxiliary hydraulic attachment. See "Implement Auxiliary Flow Control" under "Machine Settings" **3-51** on the display for details on how to adjust the auxiliary flow rate upper limit.
- 2nd auxiliary hydraulic — Operate the hydraulic component attached to the secondary auxiliary hydraulic ports.
- 2-Speed and Creep speed setting — Press  to downshift from 2nd gear to 1st gear. Press  to shift back to 2nd gear. For more details refer to **3-22**. This rocker switch is also used to increase and decrease machine speed in creep mode. For more details on creep mode see **3-32**.
- **Ride Control™** — Squeeze and hold the control lever trigger to activate **Ride Control™** and release to deactivate. **Ride Control™** reduces machine rocking motion during transport and material hauling operations. When engaged, loader down pressure is limited to the weight of the loader plus the attachment, and also reduces shock loads to the machine. The weight of the attachment is hydraulically cushioned during transport. See "**Auto-Ride Control™** (ARC) **3-36** for more details.
- Float — Press to activate or deactivate the lift arm float function. When float is activated, the lift arm will float over the ground contour the machine is traveling over. For more details refer to page **3-14** for the H control pattern, and page **3-18** for the ISO control pattern.
- Multi-function electric ON/OFF — Electronically activates an attachment connected to the machine's auxiliary hydraulics.
- Multi-functional electric #1, #2, and #3 — Press to electrically control additional components attached to the machine's auxiliary hydraulics. Refer to the owner's manual of the attachment for operating functions.

NOTE: If vehicle is equipped with optional Enhanced High Flow (EHF) auxiliary hydraulics, multi-function electric #2 will be controlled by a rocker switch on the front left-hand console. See "Left-hand column switch identification" **3-28** for more details.

Level 350 control levers

- Left-hand side control lever
(1) Multi-function electric ON/OFF
(2) Multi-functional #2
(3) Multi-functional #3
(4) Horn
(5) 2-Speed / Creep

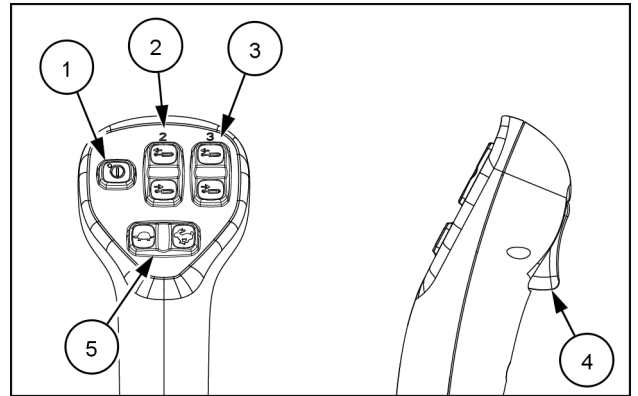

RAIL19SSL0014AA 1

- Right-hand side control lever
(1) Proportional auxiliary with detent
(2) Multi-functional #1
(3) Ride Control™
(4) Float
(5) Park brake

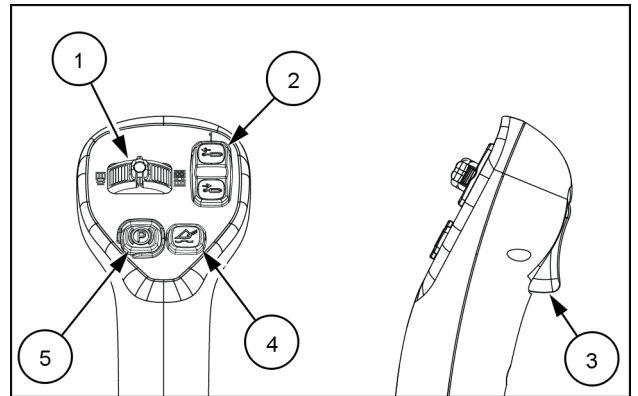

RAIL19SSL0012AA 2

Level 450 control levers

- Left-hand side control lever
(1) Multi-function electric ON/OFF
(2) 2nd auxiliary hydraulics
(3) Multi-functional #3
(4) Horn
(5) 2-Speed / Creep

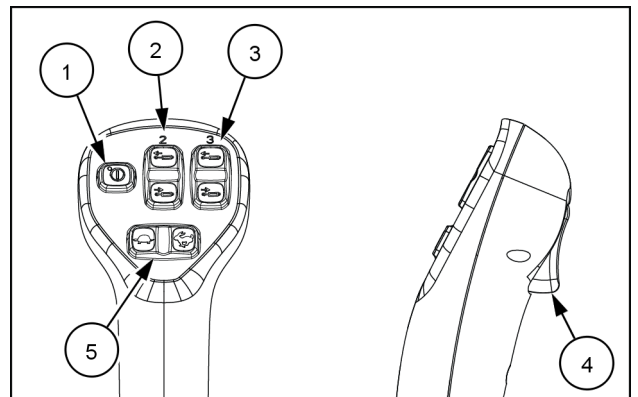

RAIL19SSL0014AA 3

- Right-hand side control lever
(1) Proportional auxiliary with detent
(2) Multi-functional #1
(3) Ride Control™
(4) Float
(5) Park brake

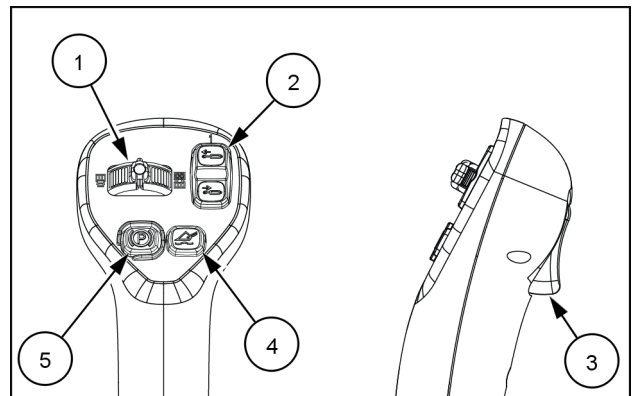

RAIL19SSL0012AA 4

Two-speed function

Function-enable conditions

The two-speed function can be activated ONLY IF ALL of the following conditions are met.

- The operator is in the operator's seat.
- The restraint bar is in the down position while the operator is in the seat.
- The machine is running.
- The hydraulic system is activated.
- Park brake is not set.

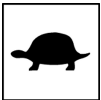

Two-Speed Function



Press the turtle symbol to downshift from 2nd gear to 1st gear.



Press the rabbit symbol to shift from 1st gear to 2nd gear.

NOTE: An  will appear inside the gear symbol on the display while in 1st gear and an  while in 2nd gear.

NOTE: The 2-speed function buttons are also used to increase or decrease the machine speed in creep mode. See "Creep mode" 3-32 for more details.

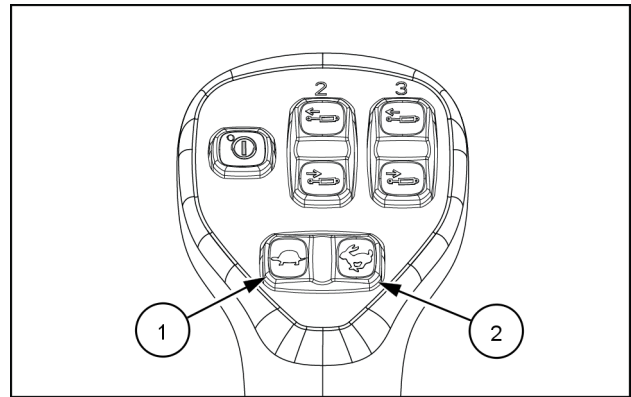

RAIL19SSL0015AA 1

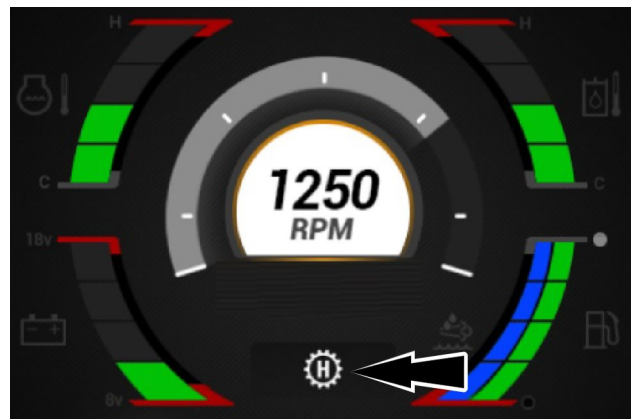

RAIL21SSL0203PA 2



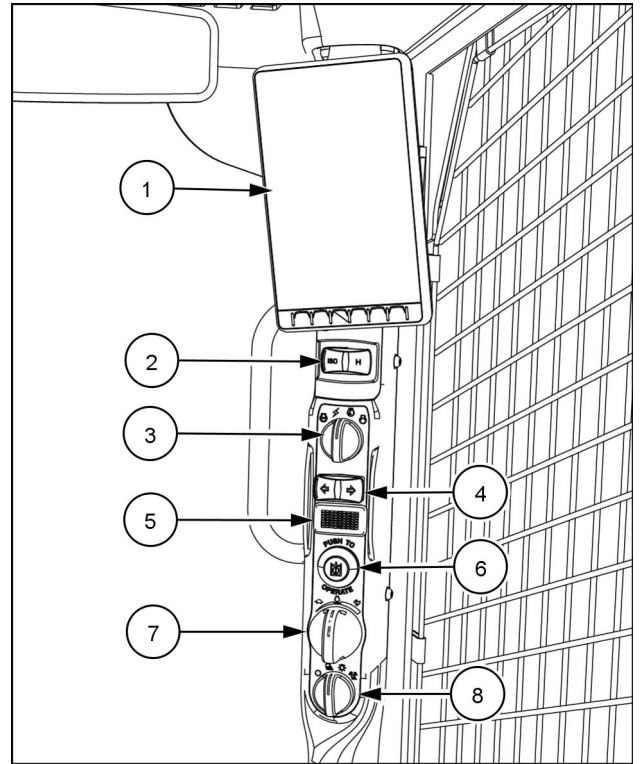

RIGHT-HAND COLUMN SWITCH IDENTIFICATION

Component Identification

(1)	<p>Multi-functional Liquid Crystal Display (LCD)</p> <p>Information will be displayed on the LCD as directed by the operator or automatically by machine operations. The screen offers prompts to assist the operator when programming machine functions and/or performing diagnostics. The display will power on when an operator sits in the operator seat. The ignition knob does not need to be in the Accessory, Run, or Start position. See the Vehicle Display Chapter starting on 3-37.</p> <p>NOTE: The display will shut off 30 s after the operator sits down unless the ignition knob is turned to the Accessory, Run, or Start position</p>
(2) ISO/H	<p>ISO or H pattern control switch</p> <p>On machines with ISO or H drive, the switch (2) determines which drive system the machine is operating. ISO drive (single lever controls drive) or H drive (traditional two lever drive control). See "ISO or H pattern control switch" 3-26 for more details.</p>



RAIL19SSL0071BA 1

(3)	<p>Ignition knob (four position)</p> <p>NOTE: Follow the starting procedure 4-2 described in this manual.</p>
	<p>Stop position Turn the knob to the Stop position. The engine will stop and the electrical system will be inactive to the operator.</p> <p>NOTE: Some electrical components continue to receive power from the battery.</p>
	<p>Accessory position Turn the knob to the left, the machine's electrical system is now active.</p> <p>NOTICE: Do not leave the knob in this position otherwise you may drain the battery power.</p>
	<p>Run position Turn the knob to the RUN position. The machine's electrical system becomes active, the system checks all starting criteria is met, and prepares the engine for starting.</p>
	<p>Start position (temporary position) Turn and hold the knob to the Start position, release the knob to the Run position once the engine starts.</p> <p>NOTICE: Do not operate the starter motor continuously for more than 30 seconds.</p>
(4)	<p>Turn signal indicator (if equipped)</p> <p>When operating on the public roads use the turn signal switch to indicate the direction of travel. The direction selected will flash until you turn it off.</p>

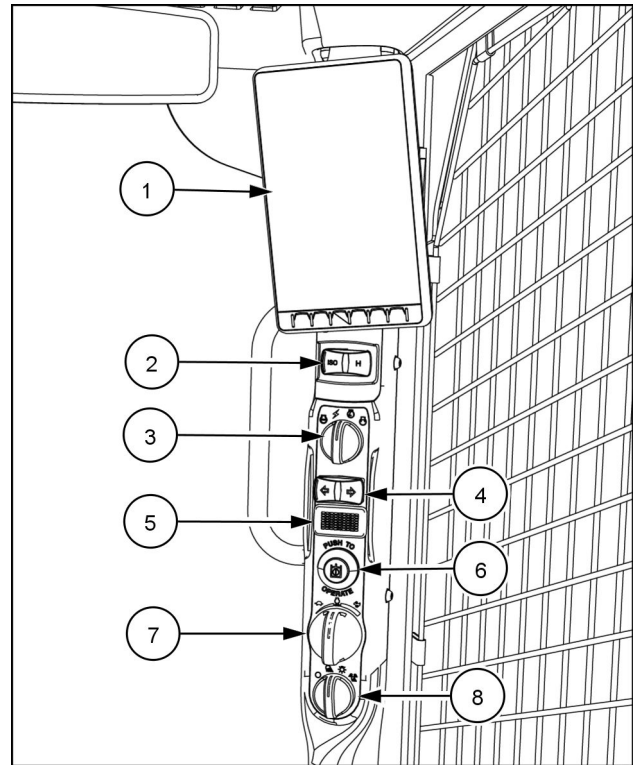





RAIL19SSL0071BA 2

3 - CONTROLS AND INSTRUMENTS

(5)	MICROPHONE (if equipped)
	Microphone for hands free calling. Refer to the radio user guide for pairing your smart-phone with the Bluetooth® radio (if equipped).

(6)	PUSH TO OPERATE
	This button activates and deactivates the hydraulic system when the engine is running. NOTE: The operator must be in the seat with the seat belt fastened and the restraint bar lowered. After the operator starts the machine, the operator must push the OPERATE button to activate the loader arms and ground drive.

(7)	ENGINE THROTTLE
	This dial increases or decreases the engine RPM.

(8)	WORK LIGHTS			
Position	Front work lights	Side work lights	Rear work lights	Rear red lights
	OFF	OFF	OFF	OFF
	ON	OFF	ON	OFF
	ON	OFF	OFF	ON
	ON	ON	ON	OFF

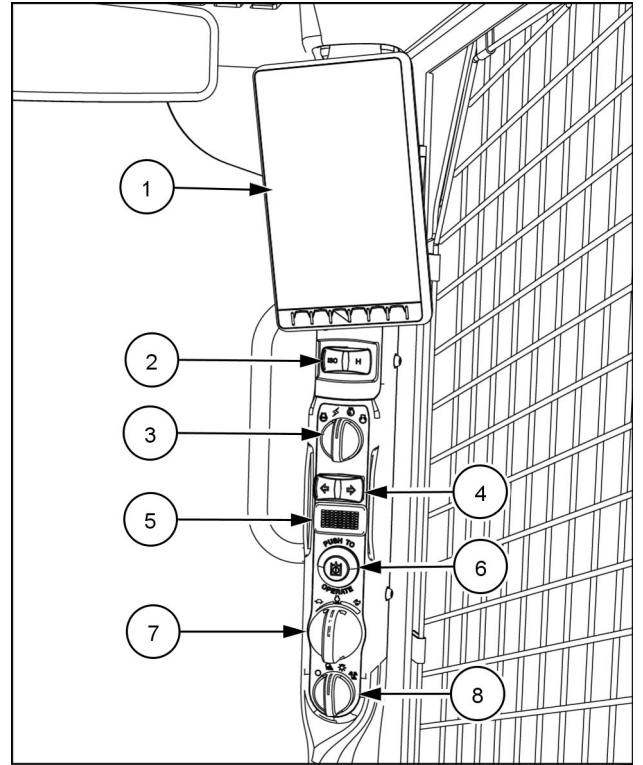

RAIL19SSL0071BA 3

ISO or H pattern control switch

On machines with ISO or H drive, switch (1) determines which drive system the machine is operating. ISO drive (single lever controls drive) or H drive (traditional 2 lever drive control).

Switching from ISO to H pattern

1. Press the OPERATE button (2)
 - The Park light will illuminate
 - The ground drive and loader hydraulics will not function
2. Confirm that the AUX roller switch on the right-hand control lever is in the neutral position. The display will show "Joysticks not in neutral".

NOTE: The AUX roller switch must be in neutral to change the pattern.
3. Push and hold the ISO - H pattern select switch (1) to the desired pattern for a few seconds. An audible alarm will sound to let you know that the pattern switch is successful.
4. Reference the text display to confirm the change of the control pattern. The switch will illuminate only on the selected side.
5. Activate the hydraulic system by pressing the OPERATE button (2).

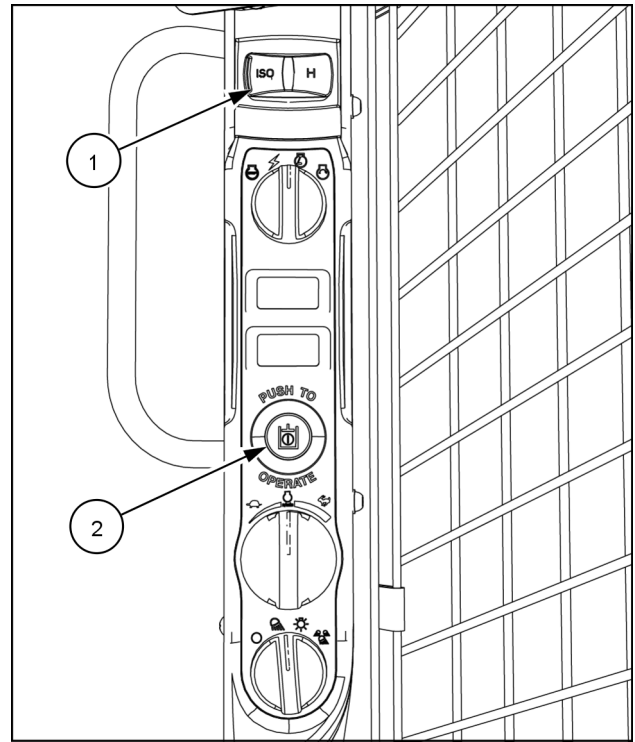

RAIL19SSL0069BA 1

Bluetooth® radio (if equipped)

See the **Bluetooth®** radio user manual that ships with the machine for details on radio features, controls, and operation.

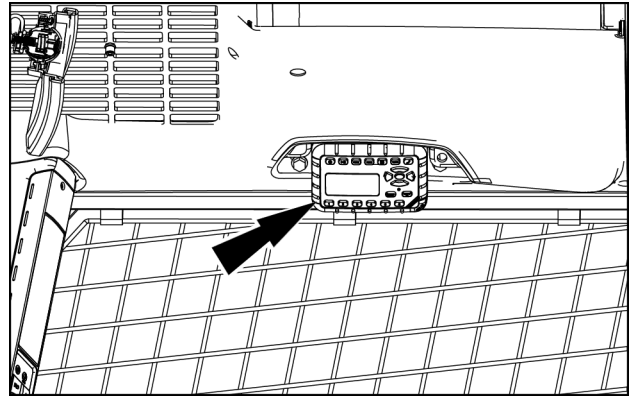

RAIL19SSL0005AA 1



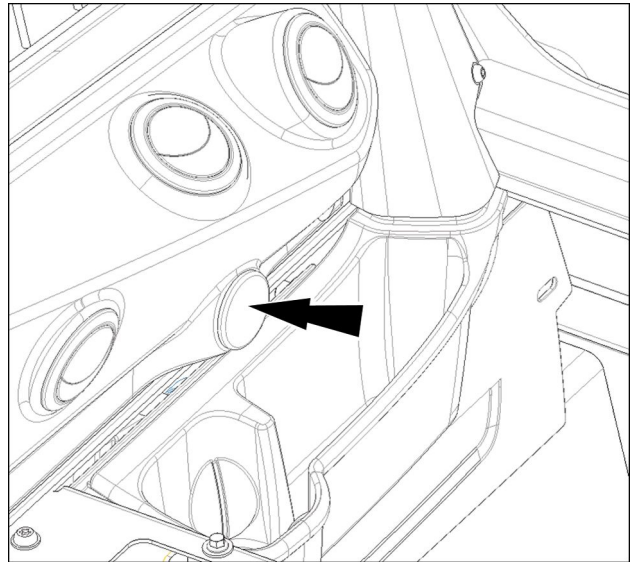

The radio has an Aux-in port and a USB port. These ports are located above the cup holder.



RAIL19SSL0052BA 2



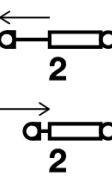

LEFT-HAND COLUMN SWITCH IDENTIFICATION

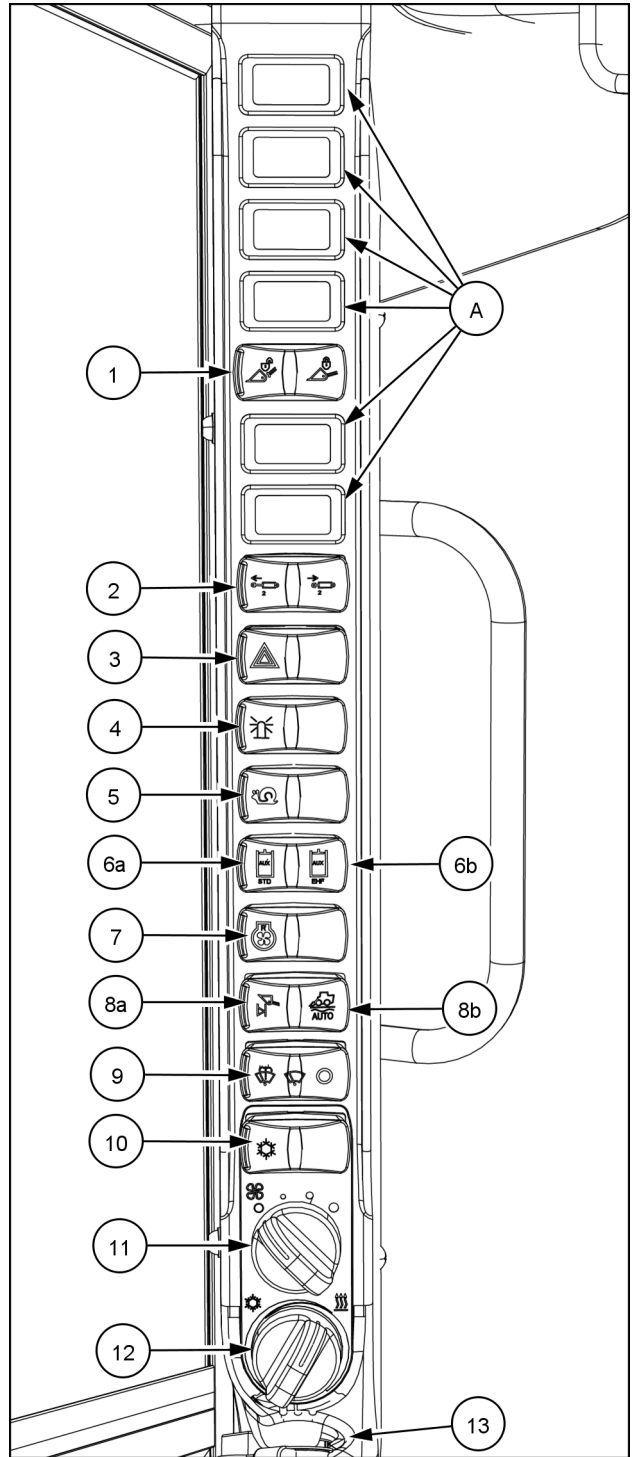
Left-hand column switch identification

(A)	Blanks
	<p>(1) Hydraulic attachment coupler switch</p> <p>Push the unlock side of this switch to unlock the coupler from the attachment. This switch must be used in conjunction with hydraulic pressure from the loader arm down, attachment curl in or the auxiliary thumbwheel on the right-hand control handle.</p>
	<p>To Lock after coupler is properly inserted in the attachment, apply hydraulic pressure from the loader arm, coupler, or auxiliary to engage the coupler pins.</p>
	<p>(2) Front Electric #2 (if equipped)</p> <p>If equipped, push switch left or right to operate attachment connected to front electrical connector.</p>
	<p>(3) Hazard flasher switch (if equipped)</p> <p>Push the switch to activate the 4-way flashers.</p>
	<p>(4) Rotating beacon switch (if equipped)</p> <p>Push the switch to activate the rotating beacon.</p>



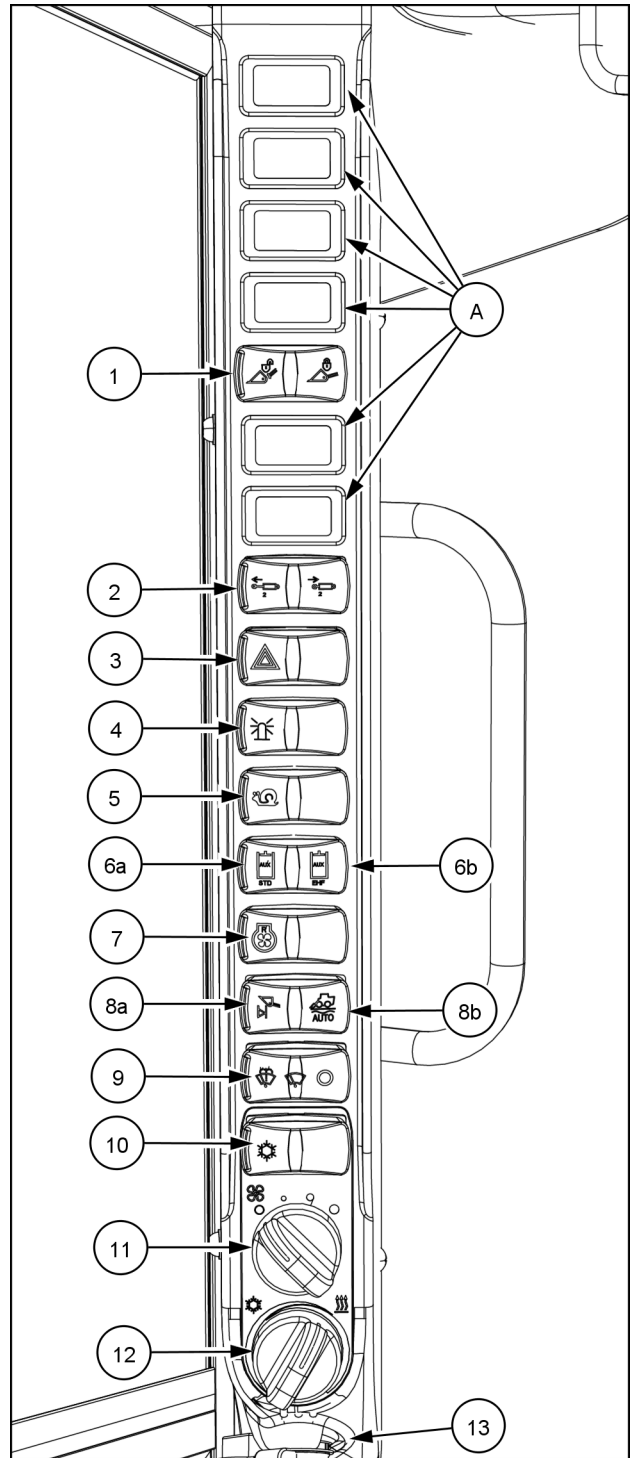

RAIL21SSL0427DA 1

<p>(5)</p> 	<p>Creep mode</p> <p>Push the switch to activate creep mode. See "Creep mode" 3-32 for more details.</p>
<p>(6a)</p> 	<p>Standard (STD) auxiliary hydraulic switch</p> <p>Push the STD side of the switch to engage standard flow auxiliary hydraulic mode. Push the STD side again to disable standard mode and revert back to high flow auxiliary hydraulic mode.</p> <p>NOTE: Standard auxiliary hydraulics shares a switch with Enhanced High Flow (EHF) auxiliary hydraulic, if equipped.</p>
<p>(6b)</p> 	<p>Enhanced High Flow (EHF) auxiliary hydraulic switch (if equipped)</p> <p>If equipped, push the EHF side of the switch to engage the enhanced high flow auxiliary hydraulic mode. Push the EHF side again to disable enhanced high flow mode and revert back to high flow auxiliary hydraulic mode.</p>
<p>(7)</p> 	<p>Fan reversing</p> <p>Use this switch to reverse direction of the engine cooling fan or activate auto fan reversing mode. See "Fan Reversing" 3-34 for more details.</p>



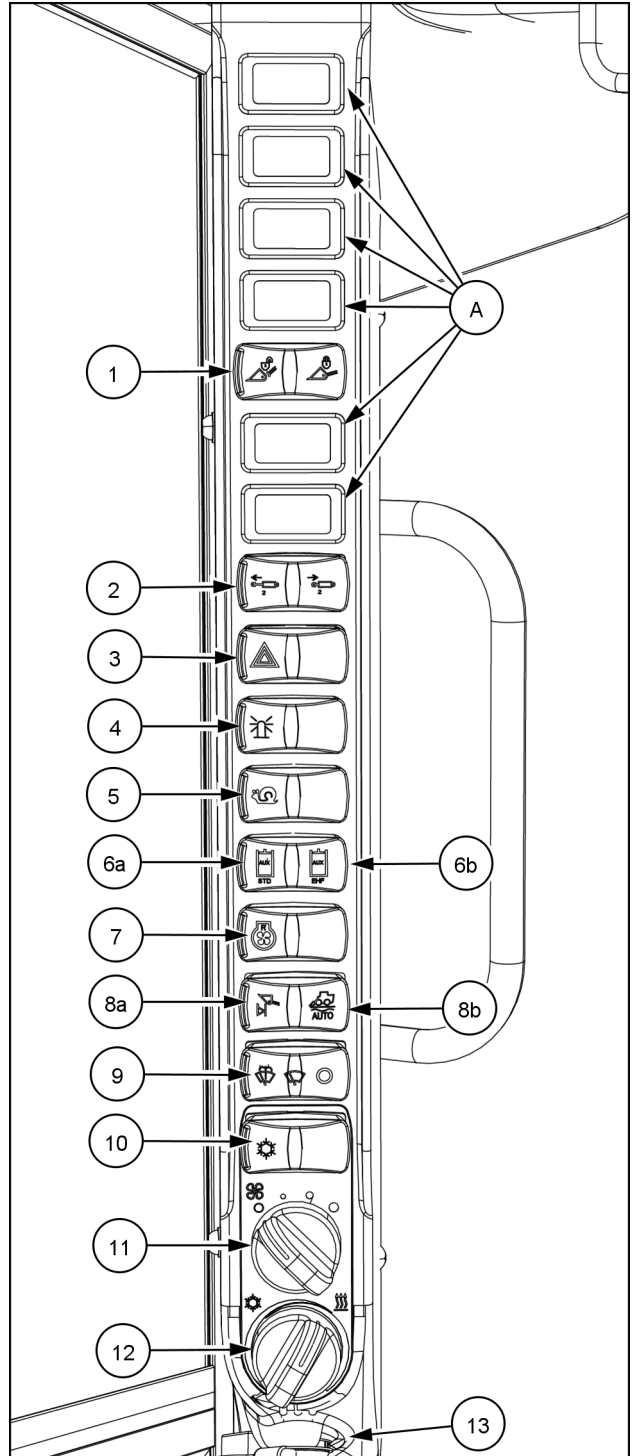

RAIL21SSL0427DA 2

<p>(8a)</p> 	<p>Self-leveling switch</p> <p>Use this momentary switch to activate the self-leveling feature. As you raise the loader arm the bucket will rotate to maintain a level position.</p> <p>NOTE: <i>Self-level shares a switch with Auto-Ride Control™.</i></p>
<p>(8b)</p> 	<p>Auto-Ride Control™ (ARC)</p> <p>Use this momentary switch to enable the Auto-Ride Control™ (ARC) feature. When enabled, the Ride Control™ feature will become active when the vehicle speed exceeds the ARC activation speed selection made by the operator in the display. See "Auto-Ride Control™" in the "Machine Settings" 3-51.</p> <p>Ride Control™ reduces machine rocking motion during transport and material hauling operations. When engaged, loader down pressure is limited to the weight of the loader plus the attachment, and also reduces shock loads to the machine. The weight of the attachment is hydraulically cushioned during transport.</p>
<p>(9)</p> 	<p>Windshield wiper switch (if equipped)</p> <p>This three position switch turns the wiper ON/OFF and operates the washer fluid spray.</p>



3 - CONTROLS AND INSTRUMENTS

<p>(10)</p> 	<p>Air-conditioning switch (if equipped)</p> <p>This switch turns the air conditioning ON or OFF. The lamp will illuminate, to confirm the system is operational, once the fan switch has been activated.</p>
<p>(11)</p> 	<p>Fan speed dial</p> <p>Rotate this dial to activate the fan and adjust the speed of the fan.</p>
<p>(12)</p> 	<p>Heating, Ventilation, Air-Conditioning (HVAC) dial</p> <p>Rotate this dial to adjust temperature.</p>
<p>(13)</p>	<p>12 V Power port</p> <p>Supplies 12 V of power for accessories.</p>

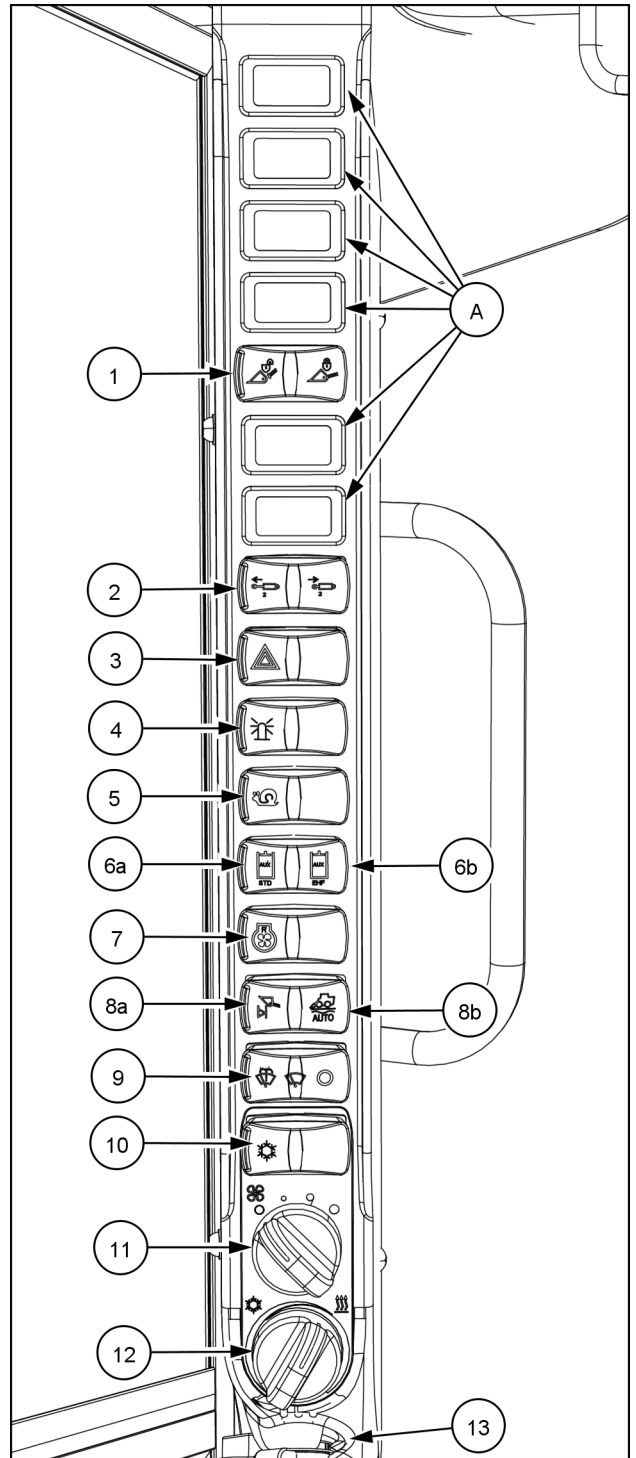

RAIL21SSL0427DA 4



Creep mode

Function-enable conditions

The creep function can be activated ONLY IF ALL of the following conditions are met.

- The operator is in the operator's seat.
- The restraint bar is in the down position while the operator is in the seat.
- The machine is running.
- The machine has no ground drive movement.
- The ignition knob switch is in the ON position.

NOTE: If the operator tries to operate creep without meeting all of the function-enable conditions the creep switch on the left-hand column will flash ON and OFF, and a message will appear on the display to give guidance to the operator on how to activate creep mode. 

NOTE: The creep feature only works when in the low speed  mode. If the machine is in 2-speed  mode when creep is activated, the machine will automatically go into low speed mode.

Activate creep mode:

1. Operator must satisfy the "Function enable conditions".
2. Press the creep mode  switch (1) on the left-hand column panel. The creep symbol will illuminate, and the display will indicate the machine is in creep mode with the creep number setting (1-100). The factory default creep setting is 50 which is equivalent to approximately **4.0 km/h (2.5 mph)**.

NOTE: Environmental conditions will affect the accuracy of the creep speed setting. Creep speed settings will be adjustable whether in neutral or during active use of the feature. See "Adjust the creep mode speed setting" in this section.



NOTE: The machine will default to the last creep speed setting before the machine was shut off.

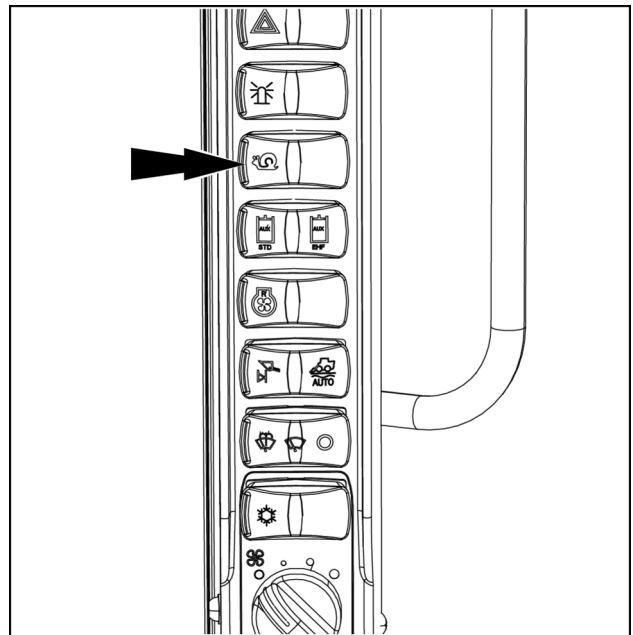



NOTE: If the operator leaves the unit running while it is in creep mode and exits the vehicle, the unit will remain in creep mode. All normal interlocks that prevent ground drive activation will be active.



RAIL21SSL0600BA 1

Adjust the creep mode speed setting:

1. Activate creep mode.
2. Press and release the  on the left-hand control lever to increase the creep speed by one increment.
3. Press and release the  on the left-hand control lever to decrease the creep speed by one increment.

NOTE: Press and hold either button  or  for a minimum of 1 second and the operator will be able to move rapidly up or down the speed setting increments until the button is released. Pressing the  will stop at 100 and not cycle back to 1. Pressing the  will stop at 1 and not cycle up to 100.

Deactivate creep mode:

1. Press the creep mode  rocker switch (1) on the left-hand column panel. The creep symbol will no longer be lit, and the display will no longer show the creep symbol or setting.

NOTE: If the machine is turned off while in creep, the creep function will be disabled until the switch is again pushed by the momentary switch to activate the function once the machine is restarted.

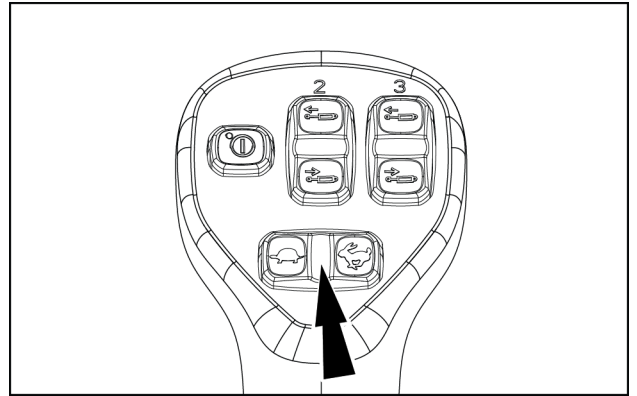

RAIL19SSL0015AA 2

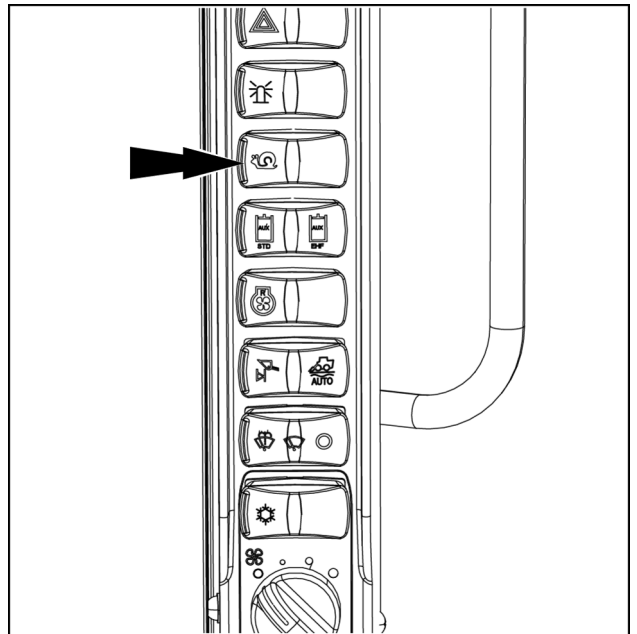

RAIL21SSL0600BA 3

Fan Reversing

The fan reversing switch has two different functions auto-cleaning and manual cleaning.

Auto-cleaning mode

1. Press and release the momentary fan reversing switch within one second, the fan mode will toggle between auto-cleaning enabled and disabled.

When auto-cleaning is enabled, the fan symbol on the switch remains illuminated.

NOTE: The duration of each cycle and the time interval between the cycles can be configured in the display. Refer to "Fan Calibration" 3-92 for details on setting the cycle duration and interval.

A fan auto-reversing cycle will occur when ALL of the following are true:

- Engine has been running for at least **60 s**.
- Auto-cleaning is enabled.
- Engine speed is greater than **2000 RPM**.
- Hydraulic oil temperature is greater than **10 °C (50 °F)**.
- Fan cleaning interval has expired.
- Fan calibration is OFF.

A fan auto-reversing cycle will end when ANY of the following occurs:

- Engine is turned off.
- Fan auto-cleaning is disabled.
- Fan cycle duration limit is reached.
- Engine coolant temperature increases by **3.0 °C (5.4 °F)**.
- Hydraulic oil temperature increases by **3.0 °C (5.4 °F)**.
- Fan calibration has started.

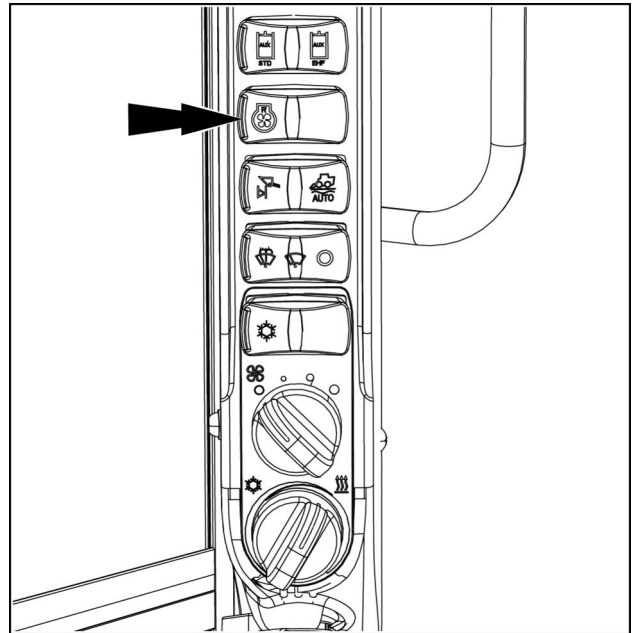

RAIL21SSL0601BA 1

Manual cleaning mode

1. Press and hold the momentary fan reversing switch for longer than one second, the fan will begin a manual cleaning cycle. The manual cleaning cycle will continue for the same amount of time set in the display for auto-reverse cycle duration unless the switch is held down longer in which the cycle will continue for up to **60 s**.

During the manual cleaning mode the fan reversing symbol will flash on and off during the cleaning cycle.

NOTE: See “Fan Calibration” 3-92 for details on setting the cycle duration.

The manual cleaning cycle will occur if ALL of the following are true:

- Fan reversing switch is held down longer than one second.
- Hydraulic oil temperature is greater than **10.0 °C (50.0 °F)**.
- Fan calibration is OFF.

The manual cleaning cycle will end if ANY of the following occur:

- Engine is turned off.
- Fan reversing switch is released during a manual cleaning cycle that has surpassed the duration limit for an auto reverse cycle.
- Engine coolant temperature increases by **3.0 °C (5.4 °F)**.
- Hydraulic oil temperature increases by **3.0 °C (5.4 °F)**.
- Auto cleaning mode is activated.
- Fan calibration has started.

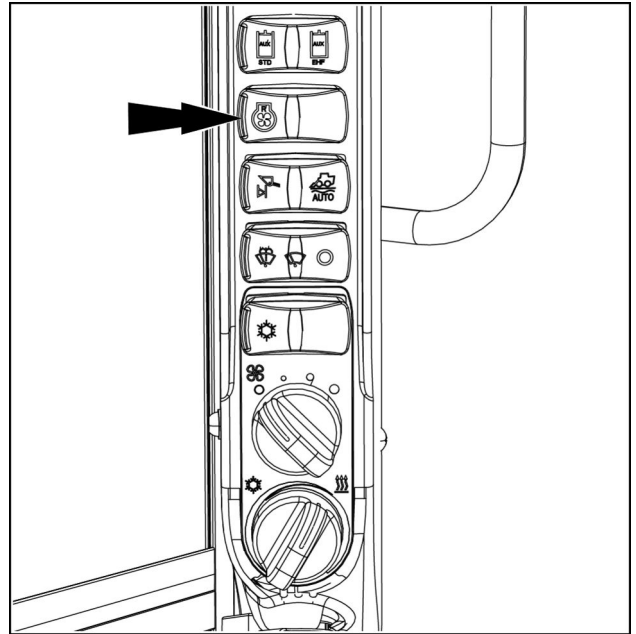

RAIL21SSL0601BA 2

Auto-Ride Control™ (ARC)

⚠ WARNING

Unexpected movement!

Stand clear of the machine. Activating ride control when the loader arm is applying down force, for example supporting or lifting the front end of the machine off the ground, may cause the machine or load to lower unexpectedly.

Failure to comply could result in death or serious injury.

W1163A

When **Auto-Ride Control™** (ARC) is active, the loader down pressure is limited to the weight of the loader and the attachment (bucket). The weight of the loader attachment is hydraulically cushioned during transport.

NOTE: *Auto-Ride Control™ should not be used for fine grading with the loader bucket or when precise placement of the loader is required.*

NOTE: *ARC speed settings can be adjusted to suit the operator's preference. See "Auto-Ride Control™" under "Machine Settings" 3-51 on the display.*

NOTE: *The Self-Leveling feature and the Auto-Ride Control™ feature share the same momentary switch and can be active at the same time.*

Auto-Ride Control™ (ARC) operation:

1. Press the **Auto-Ride Control™** (ARC) emblem to activate. When active, the **Auto-Ride Control™** icon on the display will turn green and will function anytime the machine is traveling above the speed threshold defined in the "Machine Settings" on the LCD Multi-function Display.
2. Press the **Auto-Ride Control™** to disable ARC. The **Auto-Ride Control™** icon on the display will turn gray.

NOTE: *When Auto-Ride Control™ is disabled. At any time, the operator may use the trigger on the right-hand control lever to momentarily activate **Ride Control™**. Squeeze and hold the control lever trigger to activate **Ride Control™** and release to deactivate.*

The operator may choose to leave **Auto-Ride Control™** enabled. The selection will hold even when power to the machine has been cycled OFF and ON.

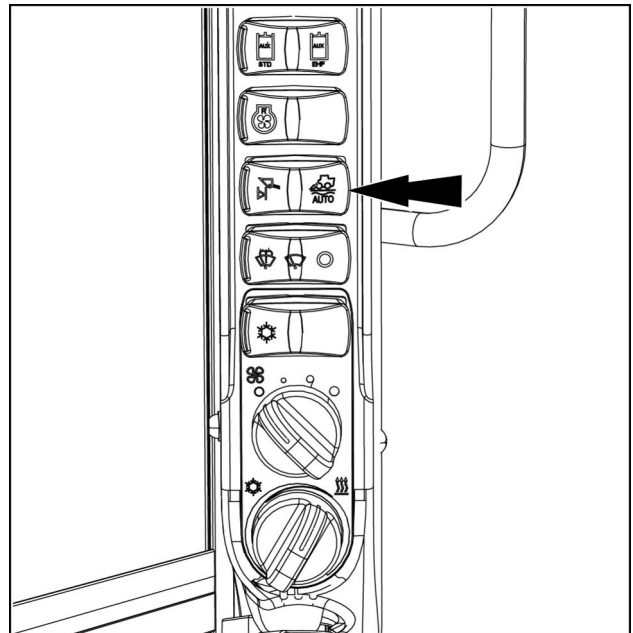

RAIL21SSL0601BA 1