

PUMA

185, 200, 220 MULTICONTROLLER
185, 200, 220, 240 CVT DRIVE



CASE IH

THE NEW ALPHA ANIMAL IN THE PACK

– our answer to the challenges of the future

The aggressive styling of the new Puma is more than a statement, it also incorporates new LED lights to make short work of long nights. This is a driver's tractor with a range of new features with the operator in mind such as:

- Generously dimensioned and illuminated steps
- A hand wash tank for hygiene next to the cab steps
- For the digital user, a new monitor holder with RAM mountings and USB sockets
- Optional compressed air connections around the Puma for easier cleaning
- Improved arrangement of key implement connections at the rear of the Puma
- A new low mounted windscreen wiper that increases the swept coverage area by 60% compared to previous Puma models.





PUMA MULTICONTROLLER

THE POWERFUL ALLROUNDER FOR MODERN MIXED FARMING AND ARABLE FARMING

- PowerDrive full powershift transmission (Puma 185 - 220)
- Proven Multicontroller armrest for excellent ease of operation
- Up to 4 (mechanical) or 5 (electrical) rear remote valves
- Headland Management Control II (HMC II) and ISOBUS II
- 540/540E/1,000/1,000E rear PTO

PUMA CVT DRIVE

THE PROVEN SOLUTION FOR FARMS AND CONTRACTORS

- CVT Drive continuously-variable transmission 4 points of 100% mechanical efficiency
- APM engine/transmission management for optimal fuel efficiency
- EcoDrive split throttle: whether transporting, baling or mowing - you're always working at the ideal and most fuel-efficient rpm
- Active hold control - safety on slopes or when leaving the cab
- 53kph at a fuel-efficient 1,550 rpm
- Hydraulic pumps with up to 170l/min flowrate
- Actively suspended front axle for superior ride quality and best traction
- AccuTurn Pro - automatic turning at the headland with GPS-based triggers of headland sequences is an option that can be added to your new Puma

Engineered from every angle	6-7
Cab	8-15
Engine, Transmission, Chassis	16-27
PTO & Hydraulics	28-33
AFS & HMC II	34-41
Service	42-47
Sustainability	48-49
Specifications	50-51

THE CHOICE IS YOURS

Your machine, your choice of comfort. Choose from our selection and tailor your Puma to your needs.





CLASSIC

Advanced features for daily operations

MULTICONTROLLER

- PowerDrive full powershift transmission (40kph Eco or 50kph optional)
- Mechanical Remotes with standard 150l/min hydraulic pump
- 4 speed PTO
- Air conditioning, passenger seat & cab suspension
- Front axle suspension is optional
- Front linkage is optional
- Standard steering with AccuGuidance ready
- Optional AFS Pro 700 display and basic HMC (Headland Management Control)
- ISOBUS Class II optional



ULTIMATE

Unlock the full potential of the tractor

MULTICONTROLLER

- PowerDrive full powershift transmission (40kph Eco or 50kph optional)
- Electro-hydraulic remotes and 150l/min hydraulic pump as standard
- 4 speed PTO
- Air conditioning, passenger seat and cab suspension
- Front axle suspension is standard
- Front Mounted 3 Point Linkage with PTO and Front Couplers are optional
- AFS Pro 700 and HMC II is standard
- Autoguidance ready on AFS Pro 700 display
- ISOBUS Class II is standard with Class III as an option

CVT DRIVE

- CVT Drive transmission continuously variable transmission
- Electro-hydraulic remotes and 170l/min hydraulic pump as standard
- 4 speed PTO
- Air conditioning, passenger seat and cab suspension
- Front axle suspension is standard
- Front linkage with Front PTO is optional
- Front hitch management is optional
- Advanced HMC II is standard
- Autoguidance ready on AFS Pro 700 display
- ISOBUS Class II or III

ENGINEERED FROM EVERY ANGLE

A choice for any requirements

The Case IH Puma has a well-established reputation as a reliable, powerful, economical tractor. It is manufactured in Austria and is available in a selection of models and performance levels. All Puma tractors have one thing in common: patented engine and exhaust system technology “made by FPT”.

PUMA MULTICONTROLLER

3 MODELS FROM 180 TO 220HP

With the Case IH Multicontroller armrest and joystick, Puma Multicontroller models put all key operating functions at the driver’s right hand. Powershift and powershuttle are operated via Multicontroller buttons, as are the operation of the rear linkage and one of the rear remote valves. Elsewhere on the armrest, features such as engine speed and electrical remote valve operation are at your fingertips, accessed quickly and easily via controls designed to be logically laid-out and easy to differentiate. Multicontroller is the last word in intuitive operation.

PUMA CVT DRIVE

4 MODELS FROM 180 TO 240HP

A leader in continuously variable transmissions since their very first development for use in tractors, Case IH today continues to lead the CVT sector with product developments that keep us at the cutting edge of the ultimate in fuel-efficient power transfer. Puma CVT Drive models are as easy to drive as they are economical, with an intuitive operating system that makes them ‘jump on and go’ machines suited to all types of operator, from casual summer staff to full-time drivers.

DESIGN

- Attractive bonnet design with large air vents for improved air intake
- Powerful LED lights integrated into the cooler grill – perfectly lighting your working area

FRONT MOUNT SPACE

- Newly-designed front hydraulics for better reactivity
- Optional Integrated front linkage with optional front linkage management and automatic PTO
- Optional Adaptive Steering Control (ASC) and programmable steering wheel revolutions
- Electronic joystick – quickly switch between rear and front remote valves

	Rated power ECE R120 ¹⁾ @ 2,200rpm (kW/hp(CV))	Maximum power ECE R120 ¹⁾ with Power Management ²⁾ @ 1,800 – 1,900rpm (kW/hp(CV))	Max. pump flow rate Standard (Optional) (l/min)	Max. lift capacity (kg)	Wheelbase (mm)
Puma 185 Multicontroller / Puma 185 CVT Drive	134 / 180	149 / 200	Multi 150 / CVT 170	10,463	2,884
Puma 200 Multicontroller / Puma 200 CVT Drive	149 / 200	164 / 220	Multi 150 / CVT 170	10,463	2,884
Puma 220 Multicontroller / Puma 220 CVT Drive	164 / 220	179 / 240	Multi 150 / CVT 170	10,463	2,884
Puma 240 CVT Drive	179 / 240	193 / 260	170	10,463	2,884

¹⁾ ECE R120 corresponds to ISO 14396 and 97 / 68 / EC

²⁾ Power Management is only available during hydraulic, mobile PTO and haulage applications





ENGINE

- 6 cylinder 6.7l FPT turbodiesel with intercooler and wastegate turbocharger
- An eye on the environment: All Puma models meet strict Euro Stage V emissions standards
- No external cooled exhaust gas return needed
- Engine power management provides up to 45hp extra boost
- Optional Reversible fan keeps the radiator grill clean
- 750 hour service interval

DRIVING COMFORT AND SAFETY

- Actively suspended and braked front axle (option)
- Cab suspension standard for all Puma models
- Premium leather seat with active suspension available
- Patented trailer brake system – Advanced Trailer Brake for Puma CVT Drive
- A new low mounted wiper increases the swept coverage area by 60% compared to previous models

HYDRAULICS

- CCLS hydraulic pumps with flowrates of 150l/min - 170 l/min at 210bar pressure
- Up to 10,464kg rear lifting capacity and 5,129kg front hydraulic lifting capacity
- Up to 5 rear electro-hydraulic remote valves
- Up to 3 electro-hydraulic mid mounted remote valves and Power Beyond connections optional

A CHOICE OF TRANSMISSIONS

- PowerDrive full powershift transmission with automatic gear changes and programmable powershuttle
- CVT Drive continuously-variable transmission from 0 – 50kph with active hold control
- Electronic parking brake for all transmission versions
- All transmission versions reach 40kph at low engine speed (40kph ECO)





THE PUMA HABITAT

More than a workplace

If you're looking for a workplace to feel at home in, the Puma CVT Drive and Puma Multicontroller have the cab for you. Extraordinary comfort and excellent user-friendliness let you enjoy even the longest drives. Your work will become an experience with our new features, such as an innovative hands-free phone system, a modern premium steering wheel and a practical RAM mount for mobile devices. Have a seat in your new cab – the future is waiting!

YOUR COMFORT ALWAYS COMES FIRST

A cab environment like no other

The Puma cab environment is designed for drivers like you. A new monitor bar caters for the digital users with smartphones and tablets.

THOUGHTFUL DETAILS

Every control element is at your fingertips. No matter which tractor configuration you choose, all models are simple and intuitive to control without hours of poring over the user manual.

HEATED AND VENTILATED SEAT

The new Puma's optional heated and ventilated red leather seat keeps you cool and comfortable in warm months.



INTEGRATED COOL BOX

This newly-developed cool box provides enough space for food and drink even for the longest working days. It is located in easy reach of the driver without impeding the view out the front.



PERFECT VIEW, DAY OR NIGHT

The perfect arrangement of front and side-oriented LED headlights with 40,000 lumens of brightness turn any night into day. Up to 20 LED working lights on the cab roof, A and B pillars provide optimal 360 degree illumination without shadows.

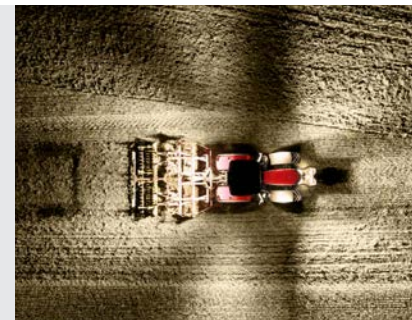

THE BEST PLACE FOR YOUR MOBILE DEVICES

The RAM monitor mount allows mobile devices such as tablets to be positioned perfectly in the driver's field of view.



NEW

LOW MOUNTED WIPER INCREASES
THE SWEEPED COVERAGE AREA BY 60%
COMPARED TO PREVIOUS MODEL.





AFS PRO 700™ TOUCHSCREEN



MULTICONTROLLER

ICP – INTUITIVE CONTROL PANEL

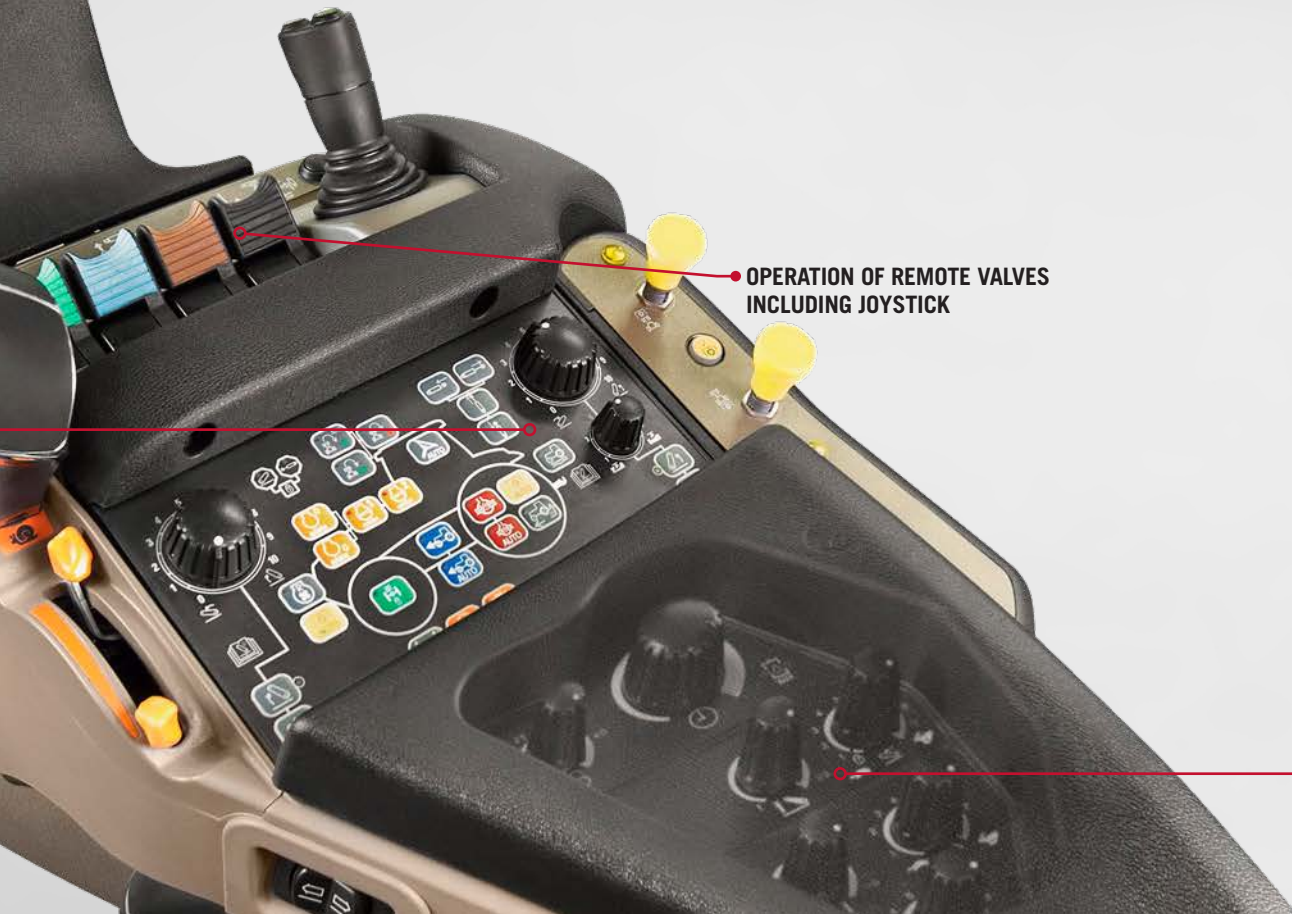

OPERATION OF REMOTE VALVES INCLUDING JOYSTICK

THE PUMA WORK STATION

Intuitive operation – maximum productivity

Time is money – and we know how busy you and your employees are.

The Multicontroller™ armrest, ICP operator's panel and AFS Pro 700™ touchscreen monitor combines all the key tractor functions. The Intuitive Control Panel has the major Puma tractor functions located in a logical layout at the centre of the Multicontroller™ armrest - it's easy to follow and understand for all drivers allowing the operator to quickly get the full potential from the Puma in the field.

TRUST IS GOOD, CONTROL IS BETTER

The tractor's performance monitor is located on the right A-pillar. It displays all basic settings and tractor information in a clear, comprehensive overview.

HYDRAULIC AND REMOTE
VALVE SETTINGS

Diesel gauge and engine
coolant temperature

Warning light display

Gear settings display

AdBlue gauge display

Performance monitor

Keypad for selecting/
programming the displays



AFS PRO 700: ONE MONITOR, INFINITE POSSIBILITIES

Look to the future!



CUSTOMISABLE FOR YOUR NEEDS

The AFS Pro 700 monitor provides an overview of all tractor functions. Choose up to 12 important Puma parameters and store them in this quick access menu to be recalled when you need them.



KEEPING AN EYE ON WHAT'S IMPORTANT

The monitor can show up to two live videos from several cameras at the rear of the tractor, or the rear of large implements. This makes backing up with implements such as large trailers or balers easier than ever.



AUTOMATED HEADLAND MANAGEMENT

The Case IH Headland Management Control II system (HMC II) can increase automation at the headland and reduce repetitive tasks, ensuring a consistent workflow. Two processes can be recorded in real time while you work, or by inputting commands on the AFS Pro 700 monitor. Triggers can include time or distance travelled, depending on the settings.



INTERFACE WITH YOUR TRACTOR

The AFS Pro 700 is the main mode of operating and supervising your Puma: all main functions and status information are bundled in one display.



Menu navigation is intuitive, with important settings accessible within seconds. This lets you get every bit of potential from your machine.

INTEGRATED AEF CERTIFIED ISOBUS IMPLEMENT CONTROL

ISOBUS is a modern tractor/implement interface allows implement operation on the AFS Pro 700. This can reduce the need for a second display in the cab. Connect via the 9-pin ISOBUS plug at the rear or front of the Puma. Puma Multicontroller and Puma CVT Drive are also compatible with ISOBUS III, which allows the implement to control tractor functions such as the remote valves, PTO, rear linkage and ground speed.



CLEAR PERFORMANCE MONITORING

You can view all the critical Puma performance and tractor functions such as oil pressure and coolant temperature on the AFS Pro 700. Regular monitoring and easy-to-understand data ensure your Puma is ready for work when you need it. For further analysis, you can choose to transfer your data from the AFS Pro 700 directly to your myCASEIH platform to analyse and improve uptime in the field, without having to record it in a notebook.



AUTOMATED STEERING AND TURNING

AFS AccuGuide and AFS AccuTurn Pro work together to provide fully automatic steering and headland turning. Combined, they can improve machine uptime in the field and reduce input costs by reducing overlaps. With AFS AccuTurn Pro, you can automate headland processes and integrate HMC II tractor and implement functions into the turning process.







THE ENGINE OF PROGRESS

Our future-oriented drive train

In the Case IH Puma range, every drive train component has been designed to work together perfectly. An innovative control system lets transmission and diesel engine work as a synchronised team, reaching new dimensions of power, performance and fuel efficiency. See for yourself how our drive train technology results in the highest quality ride and incredible working performance – get ready for the future!

DRIVEN BY INNOVATION

The next step in performance

Puma tractors are built around the latest generation Stage V-compliant FPT engines, forming the heart of a powertrain that's built to take high-output hard work in its stride. The latest 6 cylinder engines are also designed for longer 750 hour oil and filter change intervals.

The 6.7 litre 4-valve engine with Common Rail highpressure fuel injection and wastegate turbocharger delivers performance, torque, fuel efficiency and reliability between 180 and 240hp (rated). All models benefit from an innovative power management system that provides an extra power boost when transporting heavy loads or moving at higher speeds. This intelligent engine control system is available with all transmission options.

STRENGTH WITHOUT COMPROMISE

All engines can generate up to an amazing 46% torque rise. With this large reserve, torque can be increased even while engine speed drops under heavy load. With a broad constant power range of constant power, the engine can achieve its full potential even at low speeds, which improves fuel efficiency. Puma really shows its strength when pulling heavy loads. You'll be able to use this power all day long thanks to an oversized 390 litre fuel tank.

EXCEPTIONALLY ECONOMICAL

The optional engine back-pressure brake saves you money by saving your brakes, both on the tractor and on the implement. The electronic Vistronic fan has been tuned for maximum fuel efficiency, ensuring need-based cooling performance rather than cooling speed based on engine speed. The reversible Eco fan promises even greater efficiency and reliability.

THE LEADING PIONEER OF SCR TECHNOLOGY

Case IH was one of the first companies to implement the innovative SCR solution, making us a technology leader in this area. FPT Industrial's patented "High Efficiency Selective Catalytic Reduction" (HI-eSCR 2) allows all Puma models to meet strict Euro Stage V emissions standards. The maintenance-free exhaust gas aftertreatment system and efficient combustion eliminate the need for an external cooled exhaust gas return (EGR). Optimal combustion and highest possible efficiency are guaranteed in any condition.

ADVANTAGES

- FPT Engines with 225hp to 270hp Maximum Boosted output @ 1800/1900 (CV)
- Stage V compliant emissions with HI-eSCR 2 exhaust gas aftertreatment
- No exhaust recirculation
- Up to 45 hp additional boost with Power Management
- 750 hour service interval
- Fuel tank with up to 388l capacity
- Optional reversible Eco fan available

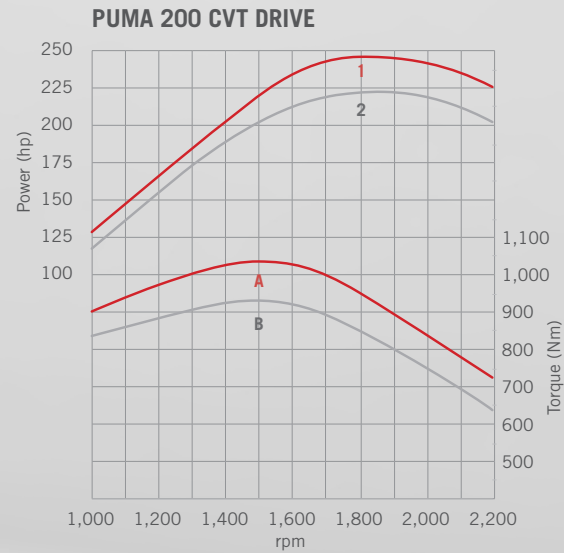

Curves 1 and A with Power Management
Curves 2 and B without Power Management

HI-eSCR2

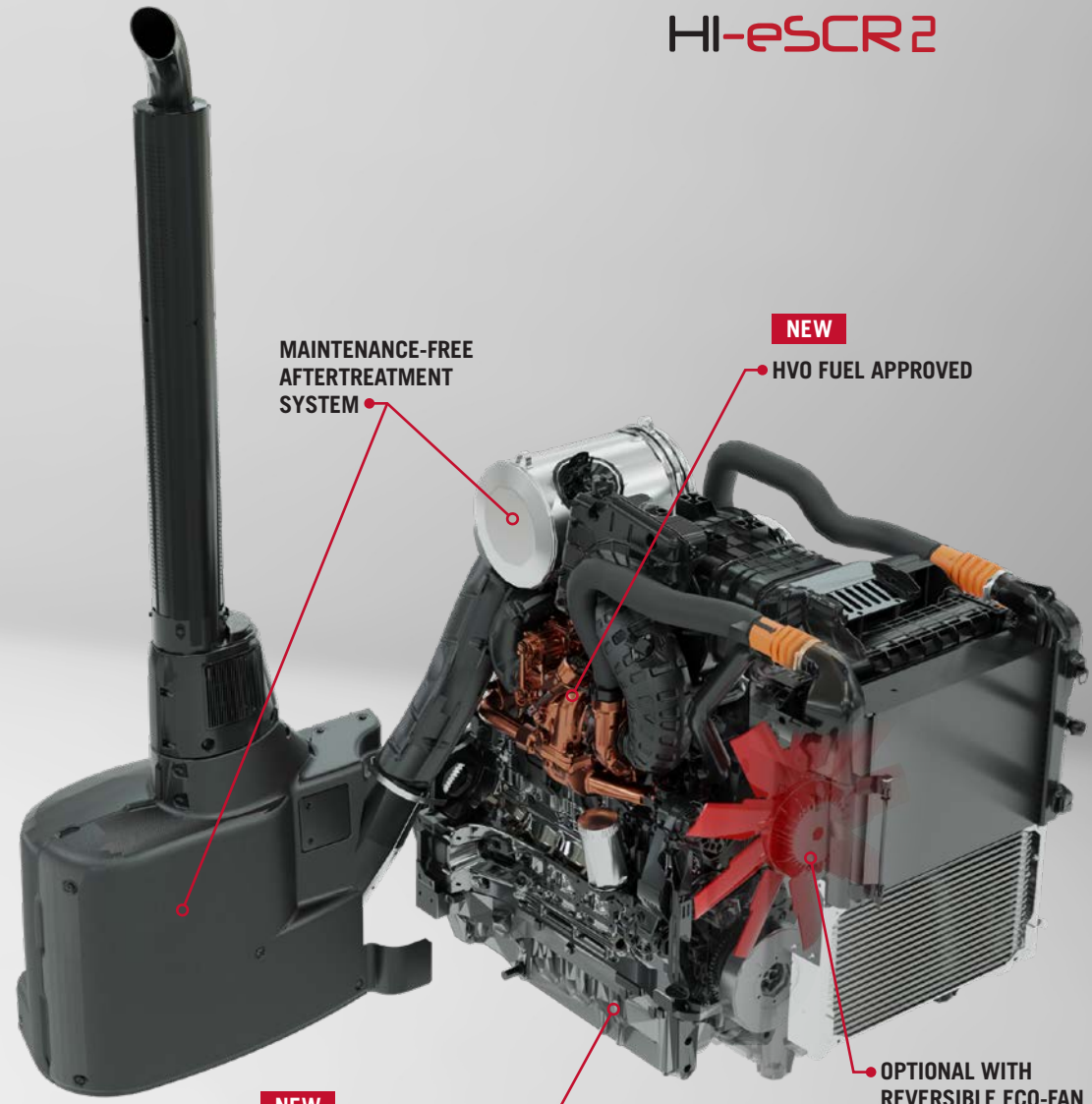

ENVIRONMENTALLY FRIENDLY

Hydro-treated vegetable oil, or HVO, is a bio-synthetic diesel that is fully compatible with the Stage V FPT engine. Combined with the extended service intervals and biodegradable transmission oil, HVO compatibility cements the Puma's eco-credentials.

NEW
+25% EXTENDED SERVICE INTERVALS (750 HOURS)

NEW
HVO FUEL APPROVED

OPTIONAL WITH REVERSIBLE ECO-FAN



ONE COMPONENT WITH MANY POSSIBILITIES

The right transmission for the job

Case IH recognises that no two farm businesses are the same and every one demands different things from its tractors. That's never truer than in the transmission department, where what suits one operation may not be right for another. What will the new tractor's main jobs be? How do my employees and I prefer to work? This is why Puma, one of the most versatile tractor ranges in the Case IH line, is offered with two transmission options.

THE FULL POWERSHIFT

PowerDrive is a 19 speed full powershift transmission. Designed to provide the optimal number of gears with no clutching or torque interruption in the crucial 2.5kph to 14kph working range.

The advantage of Powerdrive is the ease of operation. The Puma Multicontroller puts the transmission control literally in your hand.

A creep speed option is also available for speed sensitive tasks.

ADVANTAGES

- PowerDrive full powershift transmissions with 19x6 40kph ECO or 50kph
- Fully automatic range change
- All transmissions available with creep speed

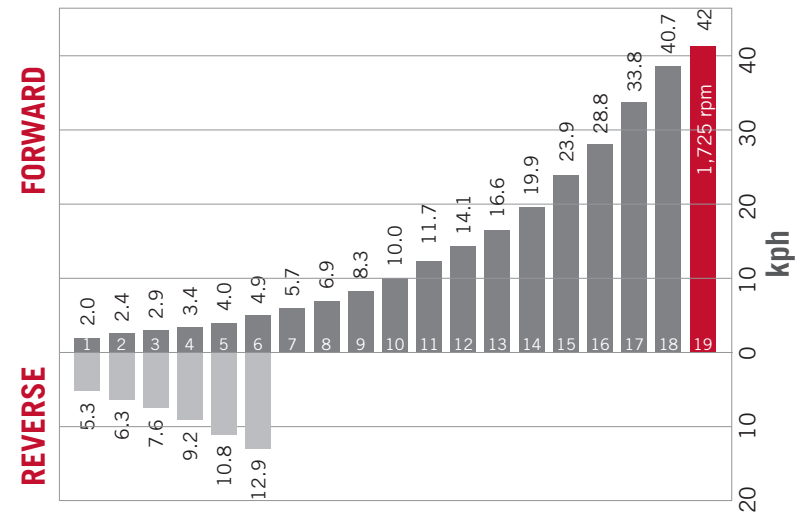

Max. speed 19 x 6 PowerDrive full powershift transmission 40kph ECO



CVT DRIVE TRANSMISSION – SEAMLESS ACCELERATION BETWEEN 0-50KPH

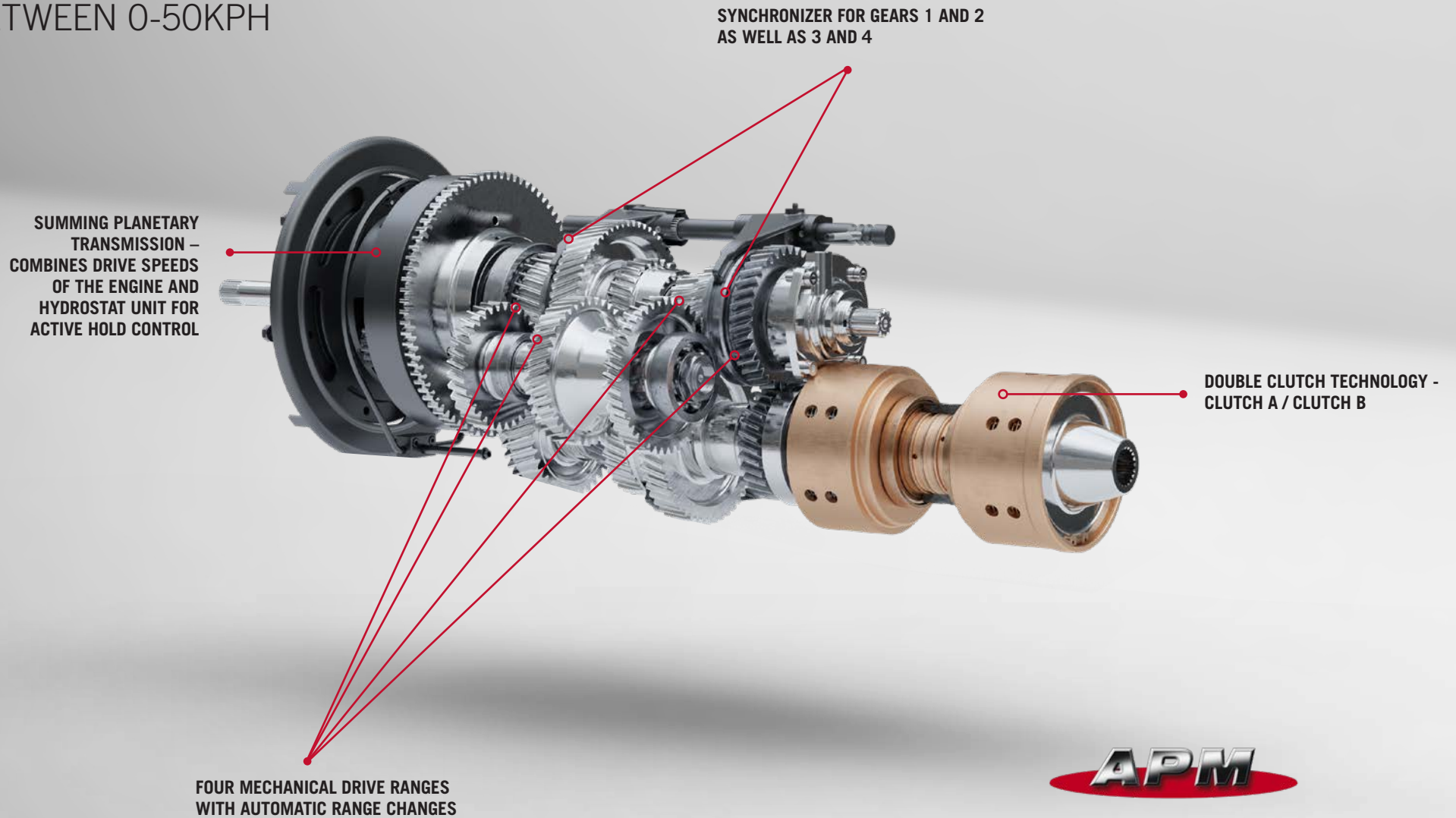

SIMPLE TO OPERATE

Set the speed – APM takes care of the rest

EXPERIENCE GIVES YOU THE EDGE

Continuously-variable power

Case IH developed the four-range continuously variable design in the mid 90s - the first tractor manufacturers to do so. Over two decades of experience have let our engineers improve and expand upon this innovation.



A NEW DRIVING EXPERIENCE WITH CUSTOMISABLE TRANSMISSION SETTINGS

Case IH software engineers have enhanced the performance and driveability of the CVT Drive with new CVT control features that deliver smoother and more responsive characteristics, increasing uptime in the field.

Drivers can change the settings easily and quickly via the AFS Pro 700 display.

- Acceleration / deceleration
- Shuttling speed
- Drive pedal behaviour

PERFECTLY BALANCED COMPONENTS

The CVT Drive transmission is one of the most efficient in the industry. The four-range hydro-mechanical design can transfer a high proportion of the engine's power to the ground, turning energy into work.

There are four points of 100% mechanical efficiency, three in the key field working speeds and one aimed at transport work.

The sophisticated interplay of the planetary gears, double clutch, four automatically shifting ranges and the hydrostat unit delivers this continuous power from 0 to 50kph.

INTELLIGENT EFFICIENCY

The APM engine/transmission management system automatically recognises the selected ground speed and adjusts engine speed and gear ratio to maximise performance. The driver need only move the Multicontroller or step on the foot throttle, APM takes care of the rest. For even greater fuel economy, top speed is achieved at just 1,550rpm – perfect for transport work. Puma CVT Drive is also a winner when it comes to slow working speeds, with minimum speeds of 0.02kph.

INTUITIVE OPERATION HAS MANY ADVANTAGES

With the EcoDrive throttle, the driver can set minimum and maximum engine speed in order to adjust power output to the job at hand. If you are working with a constant speed memory, you can set the right controller to the lowest value that the engine may be reduced to. If the engine RPM drops any lower, APM automatically slows the tractor, saving fuel.

SAFE AND STRESS-FREE WORK

Active hold control is always a standard feature. It automatically prevents the tractor from rolling on slopes, without needing to activate brakes or clutch. To continue forward, simply push the Multicontroller forward.

READY FOR ANY TERRAIN

Taking a new path

With an excellent power-to-weight ratio and a high maximum permissible weight, Case IH Puma tractors are strong in the field and on the road.

A TRACTOR WITH PERFECT TRACTION

Puma's automatic 4WD and differential lock systems can be automatically switched on and off where necessary, to combine minimal wheel slippage with maximum ground protection. The standard Ride Control system minimises pitching movements when transporting heavy mounted implements.



Front axle suspension works in both directions: more comfort, better traction and safety.

TOUGH, YET GENTLE

Optional front axle suspension increases comfort, improves handling and counteracts tractor pitching caused by heavy rear-mounted implements. A sophisticated damping system provides maximum stability and offers automatic, load-dependent self-levelling. Where front axle suspension is specified, an 'active' system is used in Puma Multicontroller and Puma CVT Drive models, with sensors monitoring various parameters such as acceleration, gear changing, brake actuation, terrain, travel direction change and hitch load. The result is excellent driving stability and comfort.

THE PERFECT BALANCE

Puma tractors have a power-to-weight ratio of up to 30kg/hp, for superb traction with minimal soil disturbance.

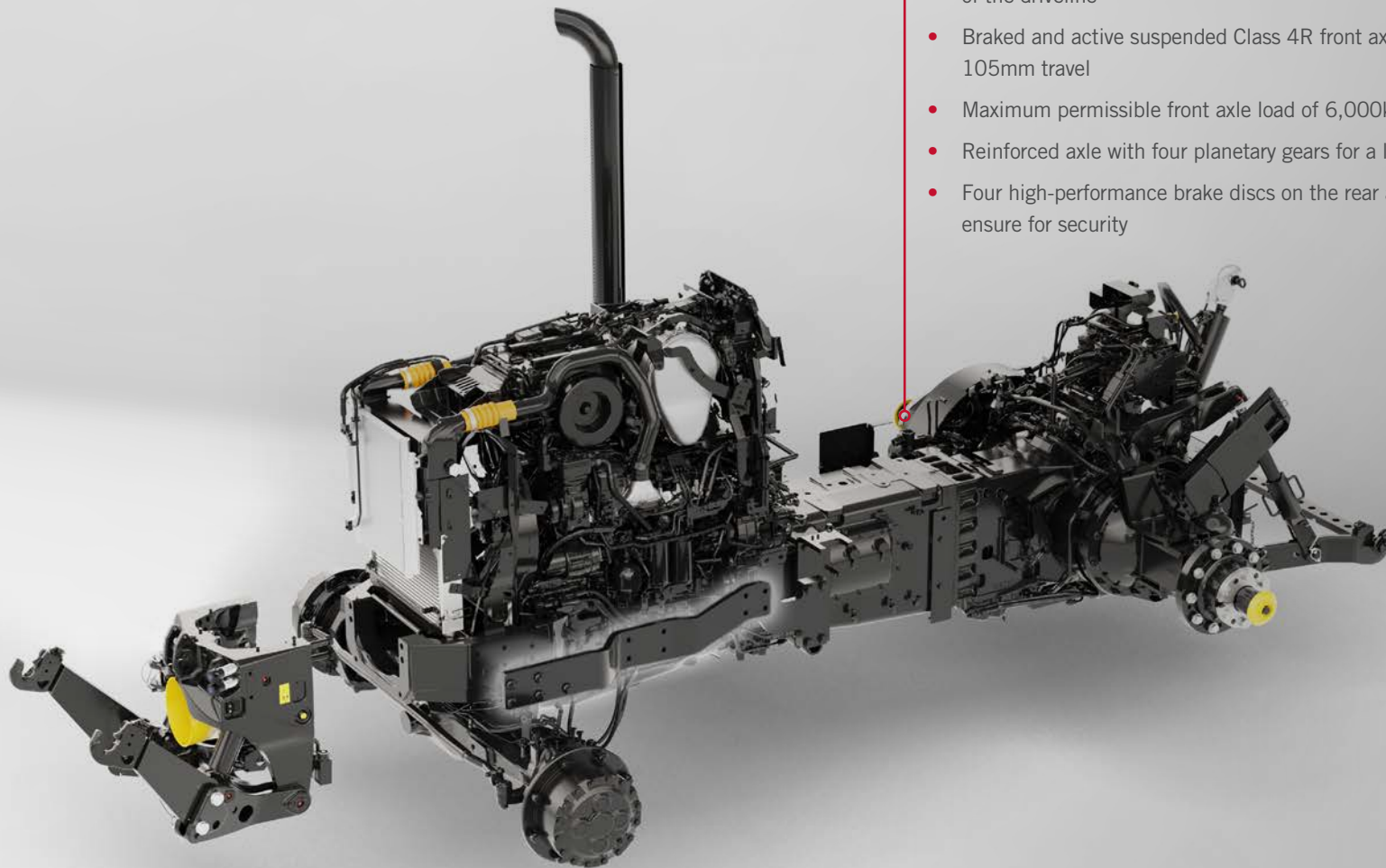

- Stable construction - high payload thanks to increased maximum permissible total weight of 14,000kg
- Optional engine block side frame increases the stability of the driveline
- Braked and active suspended Class 4R front axle with 105mm travel
- Maximum permissible front axle load of 6,000kg
- Reinforced axle with four planetary gears for a long service life
- Four high-performance brake discs on the rear axle ensure for security



DESIGNED FOR SAFETY

To protect what matters most

PATENTED SAFETY SOLUTION

The Advanced Trailer Brake equipped on Case IH Puma CVT Drive tractors enhances safety in tricky situations. The patented system actively recognises the current driving situation as well as changes to the load on the flywheel and stabilises the tractor by means of pulsed activation of the pneumatic trailer brakes. The system stabilise tractor and trailer combination when decelerating either by pulling back on the Multicontroller or using the brake pedal. The tractor and trailer stay in line.

THE CASE IH ADVANTAGE

On Puma CVT Drive models equipped with optional ABS braking, high-sensitivity sensors monitor wheel speeds and transfer this information to the ABS system, to control the braking action regardless of the driver's impact on the brake pedals, for full safety, stability and manoeuvrability. The system is enhanced by 'Steer-by-ABS' which prevents a braked wheel from locking, and 'Auto-Steer-by-Brake', which significantly reduces the turning radius.

EXHAUST BRAKE

An engine back-pressure brake is available as an option on Puma CVT Drive models. Reduces use of the service brake by up to 30% which saves wear on tractor and implement brakes.

PARKING BRAKE

All Puma CVT Drive models also feature an automatic parking brake. It activates automatically after 90 seconds or if the driver leaves his or her seat for more than 5 seconds.

WITHOUT ADVANCED TRAILER BRAKE SYSTEM

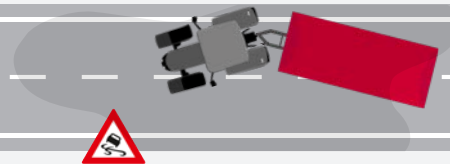

WITH ADVANCED TRAILER BRAKE SYSTEM

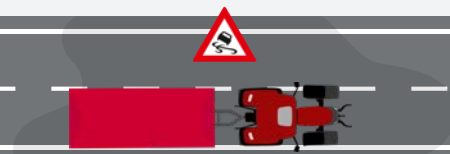

The Advanced Trailer Brake system actively recognises the current driving situation and stabilises the tractor and trailer combination by using the trailer's brakes.





A STRONG ALLROUNDER

Perfectly equipped for any job

Puma's comprehensive, high-performance hydraulics and PTO equipment makes it a true allrounder, able to manage a wide range of implements. When you need to get work done, you want a robust chassis, a tight turning radius and a high permissible total weight (14,000kg).



MORE FEATURES, MORE POSSIBILITIES

Ready for work

VERSATILITY IS KEY

Mowing, tedding, baling and more – the rear PTO has a lot of jobs to do, and Case IH has practical solutions for all of them. Puma tractors work with all common rpm speeds and even come equipped with the 4-speed rear PTO (540/540E/1,000/1,000E) options. PTO speed is easily pre-selected via a potentiometer.

WE HELP YOU SAVE

The ECO PTOs are designed especially to match engine characteristics, so that 540 ECO or 1,000 ECO speeds are achieved at just 1,590rpm engine speed. This not only saves fuel on lighter work, but also keeps the noise level down.

UNSURPASSED

Numerous additional functions ensure optimal operation: soft start engagement gradually increases torque on the driveline to prevent excessive start resistance. This reduces wear on your implements, extending their service lives. A hydraulic brake also ensures that speed is reduced immediately once the PTO is switched off.

The PTO management system (Puma Multicontroller and CVT Drive) switches the rear PTO off when the hitch has reached a predefined height, and back on again after turning, all fully-automatically. This prevents the PTO and implement from continuing to run at a bad angle to each other.

THE RIGHT SPEED AT THE PUSH OF A BUTTON

When using the PTO, the constant speed memory can be activated. AFS Pro 700 lets you preset a suitable engine speed for the implement, which is activated by pressing a button or by the HMC II. This saves valuable time and fuel.

ADVANTAGES

- Up to four PTO speeds at the rear on selected Puma models
- ECO PTO speeds for better fuel economy (540E and 1,000E at just 1,590 engine rpm)
- Front PTO with 1,000rpm and optional front linkage management

- Heavy-duty PTO clutch with soft start function
- Integrated PTO brake
- PTO with four speeds and two Economy PTO speeds (540/540E/1,000/1,000E)
- Three different PTO shafts possible

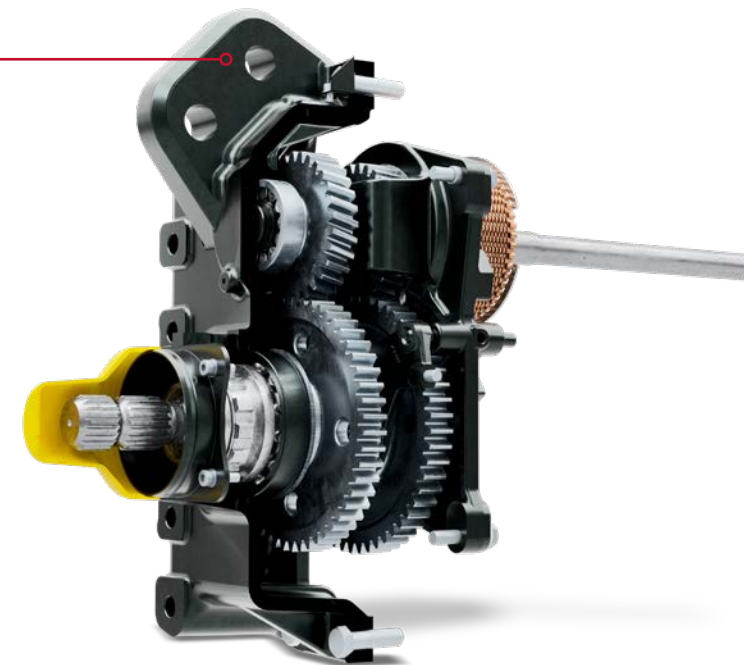

CONNECT ALL KIND OF IMPLEMENTS TO YOUR TRACTOR

Simple solutions even for the heaviest implements

A tractor's hydraulic capabilities play a large part in defining its uses. Case IH Puma tractors are fitted with high performance hydraulic pumps, hitches and remote valves, allowing you to use large implements.

MOVE IT ALL

Puma's advanced hydraulic system leaves nothing to be desired: pump flowrates of up to 170l/min are available, with up to 8 electrical remote valves and a rear hitch lift capacity of 10.5t.

PERFECTLY MATCHED

Load sensing Power Beyond connections are available so you can efficiently operate special machines requiring large flowrates. If electrical remote valves are equipped, the electronic joystick is a huge advantage as a controller, especially when using a front loader.

EVERYTHING IN HAND

Puma and Puma Multicontroller are also available with a wide range of hydraulic equipment to suit your unique needs. Choose electric or mechanical remote valves.

FRONT END TAKES THE LEAD

The Puma's front linkage can lift up to 5,129kg and can be fitted in combination with a front PTO and/or front linkage management. This opens up even more practical possibilities.

CUSTOMISED SETTINGS

If your Puma is equipped with HMC II, any remote valve can be assigned to the Multicontroller. Keep all hydraulic functions exactly where you want them. With flowrate control, you can adjust the flowrate of hydraulic oil to perfectly match the implement – either from the AFS Pro 700 monitor or via the dial encoder under the armrest cover. Timing and prioritising the remote valves is another standard function.

ADVANTAGES

- Maximum rear lift capacity of up to 10,463kg
- 5,129kg maximum front lift capacity
- 4 mechanical or 5 electrical remote valves
- Electric joystick control
- Up to 3 electrical mid-mounted remote valves
- Colour coded remotes and control switches



Pressure and flowrate-controlled hydraulic block with up to 5 electro-hydraulic remotes and Power Beyond connections



At-a-glance overview of flowrate and timer settings on the AFS Pro 700™ monitor



- Top links by their nature are heavy
- Case IH have refined the latch and stowage to make it easier work with.

- Cat. II-III quick adjust
- Cat II-III lower link with automatic stabilisers
- Optional hydraulic lifting struts
- Exterior buttons for hitch, additional remotes, and PTO on/off

- A new more ergonomic arrangement of implement connection features makes it easier and quicker to hitch up.

SMART, COST-EFFICIENT AND ECO-FRIENDLY

Case IH Advanced Farming System (AFS™)

Since its founding, Case IH has been setting milestones in the industry in terms of engines, transmissions and intuitive operating concepts. We look at existing potentials, develop suitable solutions, and implement them. We aren't satisfied until our innovations have simplified and improved your daily work.

Our AFS Advanced Farming Systems have set a trend for smart solutions in precision farming. AFS connects the tractor's and implement's control systems through full ISOBUS compatibility and HMC II headland management. Take advantage of your Puma's industry-leading technology for more performance, productivity and flexibility.





 **Ground Speed**
6.0 km/h

 **Engine Power**
54 %

 **Coverage Area**
26.3 ha

Fuel Rate
89.3 l/h  / 





CASE IH AFS™

Take advantage of maximum precision – day in and day out

Case IH Advanced Farming Systems (AFS™) have been at the forefront of precision farming for more than a decade. Case IH AFS tools include everything you need to achieve repeatable accuracy down to 2.5cm, reduce overlaps, cut operating costs and maximise your profitability.

A FULLY-INTEGRATED SOLUTION

Your Puma CVT Drive can be made “AFS™ AccuGuide Ready” on the assembly line with installation of the AFS Pro 700™ touchscreen and steering position sensors. You may also choose to retrofit a fully-automatic GPS/Glonass steering assistance system. Using the signal from a local RTK+ station gives you track-to-track accuracy of 2.5cm. The RTK system bridges breaks in reception or signal drop-outs of up to 20 minutes with the xFill app, keeping you right on track even where there is shadowing due to buildings, etc.

With the optional Case IH AFS Connect™ telematics system, your Puma CVT Drive can be pinpointed in real time from the comfort of your office. An analysis of the performance data can help you optimise logistics and efficiency coupled with lower fuel consumption.

ADVANTAGES

- Range of signal accuracies available
- Receivers use both GPS and GLONASS signals
- Low cost RTX signal solution
- Optional high accuracy RTK+ signal with accuracy levels close to 2.5cm
- Integrated automatic AccuGuide guidance
- xFill bridges RTK signal gaps of up to 20 minutes
- AFS Connect telematics provides machine tracking and performance data



Automated turning process with AFS AccuTurn Pro



xFill bridges RTK+ signal losses of up to 20 minutes

AFS CONNECT

Manage your farm, fleet and data remotely



AFS Connect lets you remotely monitor and manage your farm, fleet and data, allowing you to optimise your performance, productivity and flexibility. Efficiently visualise your equipment with little to no idle time. With all the information at your fingertips, you can successfully manage your operations anytime, anywhere!



USER-FRIENDLY INTERFACE

- New, intuitive and redesigned interface with all information at your disposal
- Ergonomic platform divided into 3 sections: fleet, farm & data

TIME-SAVING MANAGEMENT

- Visualisation of data from multiple machines in one field
- Manage your activity & transfer data from your office to machines and vice versa

MAXIMUM PRODUCTIVITY-ENHANCING DECISION MAKING

- Notifications & visualisation of critical operating parameters
- Connect and share securely with Application Programming Interface (API)

Go anywhere, see everything

RECEIVE UPDATES ON YOUR DAILY OPERATIONS

- See, share and manage data on the go, in real time, from any device
- View updated machine telematic data and fault codes remotely

THE ULTIMATE SOLUTION FOR WHEN YOU'RE ON THE MOVE

- Live vehicle map lets you find machines' locations and get driving directions
- Share vehicle info, location and directions with various apps (e.g. WhatsApp) on your phone



YOUR ALL-NEW DESTINATION FOR CASE IH PRODUCT SUPPORT

MYCASEIH is a new free cloud-based platform which gives you a single place to log in for access to everything related to your Case IH farm equipment. Find an overview of all your machine and equipment, manage your users and access a support knowledge section with operator manuals, support documents, parts catalogues and more. The platform is available on all devices: smartphone (Apple & Android), tablet and desktop.

VISIT US AT MY.CASEIH.COM





FARM MANAGEMENT

GET MORE DONE EACH DAY

Optimise your time by easily organising your fields, applications and agronomic data

MANAGE YOUR COMPANY

Managing your fields and your data can be time-consuming. AFS Connect optimises your time by easily organising your fields, applications and agronomic data. With a wealth of information at your fingertips, you can boost your operation's performance.

Data visualisation: access agronomic data in near real-time for all your seeding, application and yield activities. Included: topographic, weather, equipment, or prescriptions information.

Reporting: capture all of your critical farming information on the go or directly from your equipment. Plan upcoming activities, manage logistics, share data with your trusted advisors and make informed decisions.

Usability: Keeping track of everything going on in your operation has never been easier. Whether you're on the road, in the field or at the office, the intuitive user interface keeps you informed.



FLEET MANAGEMENT

TRACK, MONITOR & MANAGE YOUR ENTIRE FLEET

Efficiently track your equipment's location & view machine parameters in real time

MANAGE YOUR PRODUCTIVITY

When all your equipment operates efficiently with little to no idle time, you have the peace of mind that comes with working smarter and knowing that you're doing all you can to make the most of each growing season.

Fleet overview: access key information with detailed performance values for each machine by vehicle type. The map overview allows visualisation of connected equipment to more efficiently execute infield operations and coordinate the fleet.

Vehicle details page: access recent machine operations and get a 7 day report of the vehicle status by hours and fuel usage.

Fault history and notifications: view and filter the faults shown to the operator on the in-cab displays. Configure and setup notifications such as vehicle speeds, oil temperature, engine load or fuel level and receive them via web or via text messages.



DATA MANAGEMENT

CONNECT AND SHARE DATA

Securely share your farm data with trusted partners, anytime, anywhere

MANAGE YOUR DATA EXCHANGE

Seamlessly manage, share and move data – all while ensuring you stay in complete control with your preferred trusted business partners.

Secure data sharing: Securely share selected data with trusted partners while keeping complete control of who can access each piece of generated data.

Third-party partners: wirelessly transfer two-way data between AFS Connect and trusted third-party suppliers to make the most of agronomic data and drive daily management decisions.

Solutions for mixed fleets: Case IH customers benefit from a comprehensive solution for sharing data thanks to two recent partnerships:

- DataConnect is a new cloud-to-cloud interface, in partnership with CLAAS, 365FarmNet, John Deere and New Holland. Mixed-brand fleets owners can look forward to easier data exchange and management without compatibility issues.



AUTOMATED OPERATING SEQUENCES FOR INCREASED PRODUCTIVITY

Work productively, accurately, and in comfort with the headland management system, AccuTurn plus, and integrated ISOBUS compatibility

The monitor integrated into the operator's seat armrest gives the operator full control over all the tractor's automatic functions and connecting the reversing camera.

HMC II

All Puma models feature Headland Management Control II, which is designed to assist the driver when turning at the headland. Each step can be programmed either by time or distance travelled. In addition, triggers for various other automated functions can be set, such as lowering the engine speed after lifting the implement.

A headland sequence can be recorded while driving or programmed on the stand. The sequence can be played back manually or automatically via the Multicontroller, the ICP control panel in the armrest, or the AFS Pro 700 monitor.



ISOBUS III FOR BEST EFFICIENCY

In addition to the ISOBUS I and II standards, which suggest implement settings via the AFS Pro 700 monitor (Class I) and control implements (Class II), the Puma CVT Drive also offers ISOBUS Class III. With ISOBUS III, the implement automatically controls aspects of the Puma CVT Drive. The tractor will automatically adjust forward speed, steering (option), hitch position and PTO speed, as well as operating remote valves depending on the implement's needs. The result is perfect cooperation and improved efficiency of the implement and tractor.

ISOBUS functions can be configured onto existing controllers such as the Multicontroller, joystick and control levers.

AUTOMATED TURNING PROCESS

Our brand new AFS AccuTurn Pro technology combines headland management and headland steering processes. Turning radius, speed, and implement control when turning on headlands are automated and optimised, resulting in increased efficiency and improved comfort.

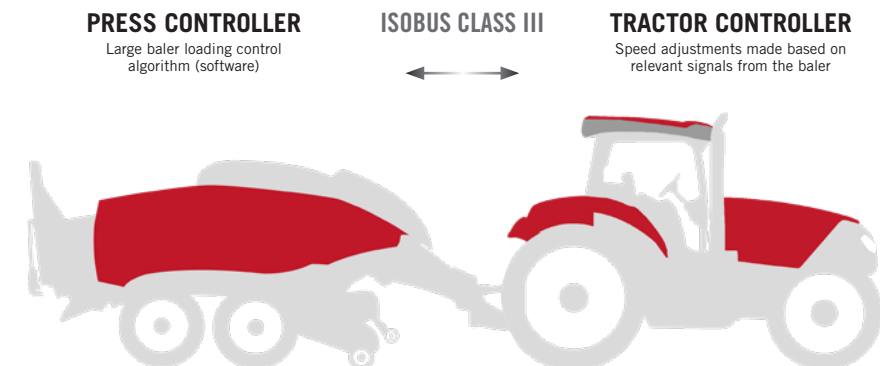







BE A FARMER

We take care of the rest

At Case IH, we see it as our responsibility to be at the customer's side anytime he or she has a question. Our intensive after sales support includes a comprehensive service package and customer service programme, which has the answer to any question. A strong local network allows us to be close to you when you need us. Our services include tech support to financing, AFS questions, service checks and even organisation and provision of the right spare parts. That's what modern service is all about.



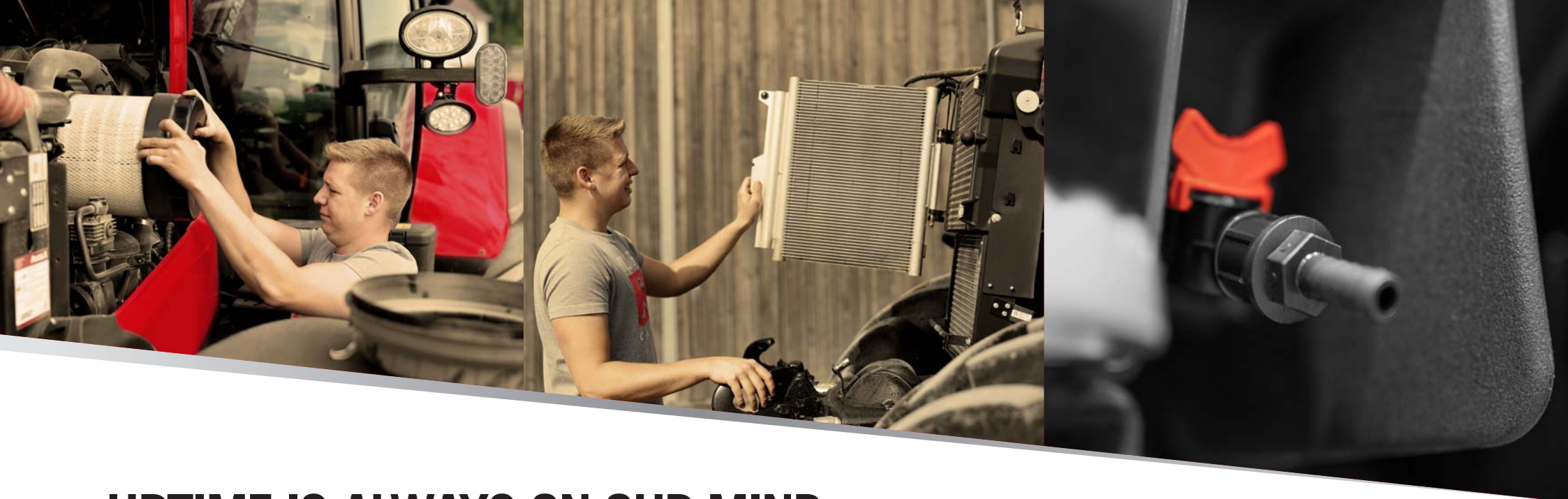

UPTIME IS ALWAYS ON OUR MIND

Because it's always on yours

DAY-TO-DAY SERVICE HAS NEVER BEEN EASIER

We know time is critical in this business, and the less you need to spend on servicing the better. Daily maintenance on Puma tractors is straightforward, easy and quick in order to reduce costs and machine downtimes.

750-HOUR OIL CHANGE INTERVALS

Industry-leading oil service change intervals help keep you in the field longer.

MAINTENANCE-FREE AFTERTREATMENT SYSTEM

Exclusive patented HI-eSCR2 technology requires no engine regeneration or additional emission components, reducing maintenance and costly downtime to a minimum.

EASY ACCESS TO THE FUEL FILTER

The filter is located on the lower right-hand side of the engine compartment to improve serviceability and access.

LARGE FUEL AND ADBLUE TANK

A large fuel tank of 390 litres guarantees long working days without refilling.

CLEAN WORK

A new 8-litre water tank on the left side allows the operator to clean his hands before entering the cab.

EXTERNAL COMPRESSED AIR CONNECTIONS

Two external compressed air connections with hose and blow off gun are available as an option. This lets you keep your machine clean or regulate your tyre pressure. A high-capacity compressor can be ordered in addition for even higher air flowrates.

SERVICE TEAM

Be a farmer. We take care of the rest

The Case IH SERVICETEAM, a strong dealer network backed up by local Case IH market teams, industry-leading Case IH support tools, modern training methods, best-in-class spare parts support and logistics performance: These provide Case IH customers with excellent all-encompassing after-sales service, keeping you farming!

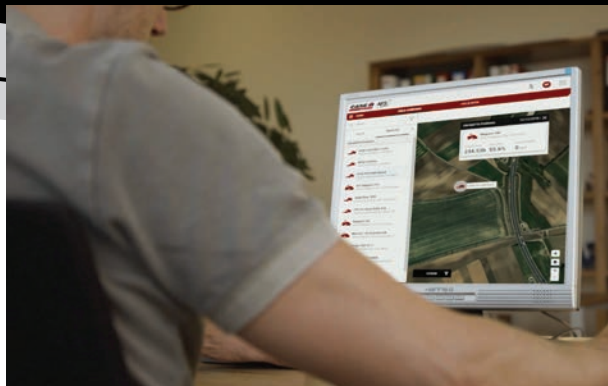

GENUINEPARTS

WE KEEP YOUR EQUIPMENT RUNNING

Your local Case IH dealer and our dedicated parts field team and their logistics colleagues are all part of the Case IH Service Team network. They're highly trained to give you expert advice and solve problems, ensuring the correct, genuine Case IH parts are located and dispatched as soon as possible to keep your machine in top condition.



OPTIMAL FINANCING SOLUTION FOR EVERY INVESTMENT

CNH Industrial Capital is the financing company for Case IH. Our employees are financial experts and have many years of experience in agriculture. We do not only know about Case IH products and the market – we also understand the individual requirements of your operations. Therefore we are always able to offer you a financial solution for your new investments that is tailored specifically to your operational requirements. Our most important goal is improving the profitability of your investments!



WARRANTY OPTIONS TO KEEP YOU COVERED

RedXtend provides a range of extended warranty options to offer protection for up to 5 years, and is designed to offer true peace of mind. It's our commitment to take care of you should the unexpected occur, beyond the standard product warranty period. You can purchase a RedXtend Protection Plan when ordering your new machine, or within 30 days from the date of delivery of your new equipment.



SUSTAINABILITY

It's a part of everything we do



**REDUCE THE CONSUMPTION OF RESOURCES
BY MOVING FROM FOSSIL FUELS TO A
RENEWABLE ENERGY SYSTEM**

Case IH is part of CNH Industrial, one of the world's largest capital goods companies. It has a firm focus on its environmental responsibilities, and has been a nine-time leader in the Dow Jones Sustainability Index.

WITHIN THE CNH INDUSTRIAL GROUP:

- 91% of waste is recovered
- 27.5% of water used is recycled
- 56% of electricity used is from renewable sources.

Being a global leader in capital goods carries great responsibilities, which means that we must be accountable for every global activity we perform. Our responsibility does not stop at the factory gate, and we have made great efforts to be proactive when it comes to the broader global issues surrounding sustainability. Over the years, our work in research and development has been geared towards ensuring that our products continue to achieve increasingly high standards in terms of safety and eco-compatibility.



**INCREASE AGRICULTURAL PRODUCTIVITY TO
IMPROVE FOOD AVAILABILITY**

Rather than limiting customers to a choice between low operating costs and ecoefficiency, our strategy is to offer products that deliver both.

By providing innovative products and solutions that abide by environmentally responsible operating practices, Case IH is doing its part to address global issues such as climate change. Today's companies face complex and interconnected challenges that demand an ever-evolving approach to sustainability, a scenario that Case IH believes is an important driver in creating long-term value for all its stakeholders, which is a core objective of the brand.

At Case IH, our engineers are focused on producing machines that not only work on the land, but work with it too.



**REDUCE ENVIRONMENTAL IMPACT AND
OPTIMISE ENERGY CONSUMPTION IN ALL
COMPANY PROCESSES**

THE SUSTAINABILITY GROWTH DRIVERS ARE:

- Necessity of feeding an increasing population
- Importance of soil protection for future generations
- Growing sustainable farming solutions
- Increasing public awareness
- Fostering public engagement



**INCREASE OPPORTUNITIES FOR
EXCHANGING IDEAS AND GOOD PRACTICES
WITH ALL STAKEHOLDERS**



MODELS	PUMA 185 MULTICONTROLLER	PUMA 200 MULTICONTROLLER	PUMA 220 MULTICONTROLLER
ENGINE			
Number of cylinders / Capacity [cm ³]	6 / 6,700		
Type / Emission level	Common Rail Diesel engine, turbocharger and HI-eSCR2 only exhaust after treatment / Stage V		
Maximum power ECE R120 ¹ Power Management ² [kW/hp(CV)]	167 / 225	182 / 245	193 / 260
Maximum power ECE R120 ¹ [kW/hp(CV)]	149 / 200	164 / 220	179 / 240
... at engine speed [rpm]	1,800		
Rated power ECE R120 ¹ Power Management ² [kW/hp(CV)]	151 / 205	167 / 225	179 / 240
Rated power ECE R120 ¹ [kW/hp(CV)]	134 / 180	149 / 200	164 / 220
... at engine speed [rpm]	2,200		
Maximum torque Power Management ² [Nm @ 1,500rpm]	940	1,035	1,100
Maximum torque [Nm @ 1,500rpm]	840	930	1,000
Torque rise standard / Power Management ² [%]	46 / 44	46 / 44	42 / 44
Fuel tank capacity, diesel / urea [litres]	390 / 48		
TRANSMISSION			
PowerDrive 19x6 full powershift 40kph ECO @ reduced rpm	●		
PowerDrive 19x6 full powershift 50kph	○		
Powershuttle	●		
Creeper	○		
Rear axle diff-lock type	Multi disc wet plate with management system		
Service brake	Hydraulically operated multiple wet disc brake, self adjusting		
POWER TAKE OFF			
Type	Shifttable with progressive electro-hydraulic engagement. Auto-PTO optional		
Speeds Standard (Option)	540E / 1,000 (540 / 540E / 1,000 / 1,000E)		
... at engine speeds Standard (Option) [rpm]	1,568 / 1,893 / (1,930 / 1,598 / 1,912 / 1,583)		
Shaft type Standard (Option)	1 3/8" 21 splines (1 3/8" 6 splines or 1 3/4" 20 splines)		
FRONT PTO AND FRONT HITCH			
Front PTO 1,000 speed @ engine rpm	2,036		
Front hitch max. lift capacity [kg]	3,620 kg Front Lift capacity through full range at 610mm in front of ball end		
FOUR-WHEEL DRIVE AND STEERING (DRIVELINE)			
Type	Electro-hydraulic with management system, differential lock as standard		
Active front axle suspension	○		
Min. turning radius ³ track setting 1,829mm [m]	6.1		
HYDRAULIC SYSTEM			
System type	Variable displacement, pressure flow compensated pump		
Max. Pump flow rate standard / system pressure	150 l/min / 215 bar		
Control type	Electronic Hitch Control (EHC) with cushion ride control		
Max. lift capacity [kg]	10,463		
OECD lift capacity through range @ 610mm [kg]	7,280		
Max. number of rear remote valves	4 Electro Hydraulic		
Max. number of mid mount valves with electronic joystick	3 electrical		
Remote valve timer control	1 - 60 seconds on all models		
Category type	Cat II-III quick adjust		
Slip control	○		

MODELS	PUMA 185 MULTICONTROLLER	PUMA 200 MULTICONTROLLER	PUMA 220 MULTICONTROLLER
WEIGHT / DIMENSIONS ³⁾			
Approximate shipping weight standard / suspended front axle [kg]	8,400 / 8,500		
Permissible total weight [kg]	13,600		
A: Max. length with front and rear lower links down standard / suspended front axle [mm]	5,467 / 5,467		
B: Total height [mm]	3,164		
C: Minimum width across rear fenders (narrow / wide type fender) [mm]	2,060 / 2,476		
D: Wheel base standard / suspended front axle [mm]	2,884 / 2,884		
E: Height at centre of rear axle, highest point cab [mm]	2,210		
F: Track setting front / rear [mm]	1,538-2,260 / 1,530-2,230		



MODELS	PUMA 185 CVT DRIVE	PUMA 200 CVT DRIVE	PUMA 220 CVT DRIVE	PUMA 240 CVT DRIVE
WEIGHT / DIMENSIONS ³⁾				
Approximate shipping weight standard / suspended front axle [kg]		8,700 / 8,800		
Permissible total weight [kg]		14,000		
A: Max. length with front and rear lower links down standard / suspended front axle [mm]		5,467 / 5,467		
B: Total height [mm]		3,068		
C: Minimum width across rear fenders (narrow / wide type fender) [mm]		2,060 / 2,476		
D: Wheel base standard / suspended front axle [mm]		2,884 / 2,884		
E: Height at centre of rear axle, highest point cab [mm]		2,210		
F: Track setting front / rear [mm]		1,538-2,260 / 1,530-2,230		

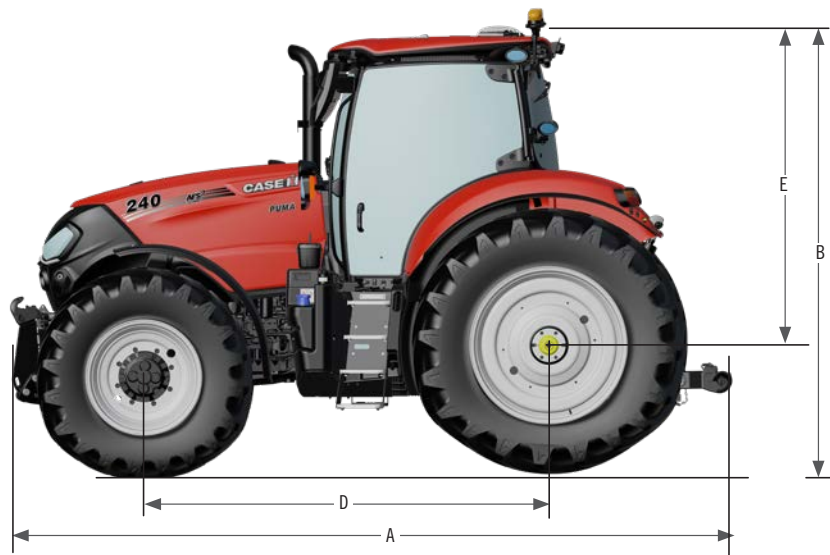

● Standard Equipment ○ Optional Equipment ■ Not available

¹⁾ ECE R120 correspond to ISO 14396 and 97 / 68 / EC

²⁾ Power Management is only available during hydraulic, mobile PTO and haulage applications

³⁾ With standard tyres ⁴⁾ Other tyres on request

MODELS	PUMA 185 CVT DRIVE	PUMA 200 CVT DRIVE	PUMA 220 CVT DRIVE	PUMA 240 CVT DRIVE
ENGINE				
Number of cylinders / Capacity [cm ³]	FPT 6 / 6,700			
Type / Emission level	Common Rail Diesel engine, turbocharger and HI-eSCR2 only exhaust after treatment / Stage V			
Maximum power ECE R120 ¹⁾ Power Management ²⁾ [kW/hp(CV)]	167 / 225	182 / 245	193 / 260	201 / 270
Maximum power ECE R120 ¹⁾ [kW/hp(CV)]	149 / 200	164 / 220	179 / 240	193 / 260
... at engine speed [rpm]	1,800			
Rated power ECE R120 ¹⁾ Power Management ²⁾ [kW/hp(CV)]	151 / 205	167 / 225	179 / 240	193 / 260
Rated power ECE R120 ¹⁾ [kW/hp(CV)]	134 / 180	149 / 200	164 / 220	179 / 240
... at engine speed [rpm]	2,200			
Maximum torque Power Management ²⁾ [Nm @ 1,500rpm]	940	1,035	1,100	1,160
Maximum torque [Nm @ 1,500rpm]	840	930	1,000	1,100
Torque rise standard / Power Management ²⁾ [%]	46 / 44	46 / 44	42 / 44	44 / 40
Fuel tank capacity, diesel / urea [litres]	390 / 48			
TRANSMISSION				
CVT Drive continuously variable transmission 50kph or 40kph ECO		●		
Powershuttle		●		
Rear axle diff-lock type	Multi disc wet plate with management system			
Service brake	Hydraulically operated multiple wet disc brake, self adjusting			
POWER TAKE OFF				
Type	Shiftable with progressive electro-hydraulic engagement. Auto-PTO optional			
Speeds Standard (Option)	540 / 540E / 1,000 / 1,000E (540E / 1,000 or 1,000 / 1,000E)			
... at engine speeds Standard (Option) [rpm]	1,931 / 1,598 / 1,912 / 1,583 (1,569 / 1,893 or 1,893 / 1,700)			
Shaft type Standard (Option)	1 3/8" 21 splines (1 3/8" 6 splines or 1 3/4" 20 splines)			
FRONT PTO AND FRONT HITCH				
Front PTO 1,000 speed @ engine rpm	2,036			
Front hitch max. lift capacity [kg]	3,620 at 610mm in front of the ball end			
FOUR-WHEEL DRIVE AND STEERING (DRIVELINE)				
Type	Electro-hydraulic with management system, differential lock as standard			
Active front axle suspension		○		
ABS Anti-lock braking system		○		
Min. turning radius ³⁾ track setting 1,829mm [m]	6.1			
HYDRAULIC SYSTEM				
System type	Variable displacement, pressure flow compensated pump			
Max. pump flow rate Standard System pressure	170l / 215 bar			
Control type	Electronic Hitch Control (EHC) with cushion ride control			
Max. lift capacity [kg]	10,463			
OECD lift capacity through range @ 610mm [kg]	7,280			
Max. number of rear remote valves	5 electrical			
Max. number of mid mount valves with electronic joystick	3 electrical			
Remote valve timer control	1 – 60 seconds on all models			
Category type	Cat II-III quick adjust			
Slip control		○		



caseih.com

SAFETY NEVER HURTS![™] Always read the Operator's Manual before operating any equipment. Inspect equipment before using it, and be sure it is operating properly. Follow the product safety signs, and use any safety features provided. CNH Industrial Australia Pty Ltd reserves the right to make improvements in design and changes in specifications at any time without notice and without incurring any obligation to install them on units previously sold. Specifications, descriptions and illustrative material herein are as accurate as known at time of publication, but are subject to change without notice. Availability of some models and equipment builds varies according to the country in which the equipment is used. ©2022 CNH Industrial Australia Pty Ltd. All rights reserved. Case IH, its respective logos and the red, black and grey colour scheme, as well as corporate and product identity used herein, are trademarks of CNH Industrial N.V. and may not be used without permission. Case IH is a trademark registered in the United States and many other countries, owned by or licensed to CNH Industrial N.V., its subsidiaries or affiliates. Printed in Australia. www.caseih.com
22CASELWPUMASTAGEV September 2022

CASE IH