

**C-SERIES MINI EXCAVATORS  
CX17C | CX26C | CX33C | CX37C**

**CASE**  
CONSTRUCTION



**AGILITY  
IN MOTION**

[www.casece.com](http://www.casece.com)

**EXPERTS FOR THE REAL WORLD  
SINCE 1842**

# MAIN REASONS TO CHOOSE THE C-SERIES



## SAFETY FIRST

- ROPS (excluding CX17C)/TOPS/FOPS certified Cab and Canopy- Emergency stop switch
- Pilot circuit with accumulator
- Object Handling Kit (CX26C / CX37C)
- Blade safety valves (CX37C)



## COMFORT COUNTS

- 1° and 2° proportional auxiliary hydraulics
- Digital cluster
- Suspension seat
- Low noise inside the cab
- Radio with USB (CX26C / CX37C)
- Air Conditioning (CX37C)



## EASY SERVICEABILITY

- Easy access to battery, hydraulic valves and all regular service components
- Easy-to-read check points
- Two-piece blade hydraulic hose



## 360° VISIBILITY

- 2-post canopy design
- Large glassed area on all cab models



## OPTIMISED TRACTION AND SPEED

- Auto shift-down
- Rubber or steel tracks from CX37C





## GREAT RELIABILITY

- Hydraulic hoses well protected inside the X-frame undercarriage
- X-frame undercarriage
- Cylinder protections
- Low risk of de-tracking with double-flange rollers



## EXCELLENT WORKING RANGE

- Long and short arms available
- Ample boom swing angles
- Wide bucket rollback angle
- Reach, dump clearance and digging depth at the top



## HIGH VERSATILITY

- Hydraulically retractable tracks (CX17C)
- Offering of integrated attachments
- Mono or bi-directional hydraulic oil flow
- Additional counterweight available



## BLADE EFFECTIVENESS

- 2-pin blade folding design (CX17C)
- Superior blade height and lift



## HIGH EFFICIENCY

- Auto-idle function (CX37C)



## EASY TO TRANSPORT

- Tie down hooks
- Less than 1,0 meter wide with retracted undercarriage (CX17C)

# THE FEATURES



## HIGH EFFICIENCY

### Clean engine and Auto-idle system

- Proven, reliable, fuel efficient, low emission and low noise Kubota T4 Final / Stage IIIA engine (CX17C and CX26C).
- Reliable and environmentally friendly T4 Final / Stage IIIA Yanmar engine (CX33C and CX37C).
- Standard “Auto – idle” on CX37C: The engine automatically decelerates to idling speed after five seconds of inactivity.  
This means less fuel consumption, less noise and less overall wear.



## HIGH VERSATILITY

### Match different customer needs

- **Working range**
  - Dig further with C-Series Minis: maximum reach has been improved to the previous series.
  - Load high-sided trucks easily: excellent dump clearance combined with superior stability make truck loading an easy task.
  - Save time: C-Series Minis deliver faster cycle times in every combined operation, thanks to their excellent boom slewing speed.
  - Choose the most suitable arm for you: C-Series Minis match different customer needs, high breakout force with short arms or outstanding digging depth and reach with long arms.
- **Attachments:** get the most of your CASE mini with the integrated range of attachments.
- **Lifting:** All models can be fitted with an additional bolt-on counterweight that further increases stability and lifting capacity. For safe lifting operation machines can be fitted with a certified Object Handling Kit.
- **Travel:** All models have the standard «auto shift-down» feature that optimises travel speed and traction. Travelling in 2<sup>nd</sup> speed the machine automatically shifts to 1<sup>st</sup> gear it needs more traction, then automatically shifts back to 2<sup>nd</sup> gear when no extra traction is required and travel speed can be increased.



# GET THE JOB DONE WITH EASE



## DESIGNED TO SAVE YOUR TIME

Agility is the name of the game

- **Reaching the jobsite:** easy with variable undercarriage width. Quick folding of blade extensions.
- **Digging:** superior hydraulic flow delivers unparalleled digging efficiency.
  - Excellent boom swing angles contribute to high versatility.
  - Choice of short and long arms available to match customer needs: high breakout force or outstanding digging depth and reach.
- **Loading:** superior dump height together with ample bucket rollback angle result efficient truck loading and maximum material retention.
- **Dozing:** excellent blade height and blade maximum lifting height.
- **Lifting:** All models can be fitted with an additional bolt-on counterweight that further increases stability and lifting capacity. The models CX26C, CX33C and CX37C can be fitted with a certified Object Handling Kit for safe lifting operation.
- **Transportation:** convenient tie-down points make transportation easy and safe.

# C-SERIES MINI EXCAVATORS



## COMFORT COUNTS

Ergonomic operator station with suspension seat

- All models feature smooth pilot controls, that make it easy and pleasant to operate them.
- CASE CX26C and CX37C feature a roomy cab with reduced sound levels and excellent visibility. Ergonomically placed joysticks and adjustable wrist rests make the Operator station a pleasant place to work in.
- The suspension seat is standard on all models.
- Front window can be easily opened and safely locked in position to improve ventilation and visibility (Cab type).

## CX17C CANOPY



## MODERN AND FUNCTIONAL CLUSTER

Easy-to-read digital cluster

The digital cluster is easy to read, confers a modern look to the operator station and provides useful information:

- Gauges: fuel level, engine coolant temperature
- Info and warning lamps: hydraulic QC lamp, travel speed, engine coolant temperature, engine oil pressure, battery charging, low fuel level

## PEACE OF MIND

ESL Anti-theft



- All C-Series minis are equipped with a standard anti-theft. It is an Engine Start Limitation (ESL) requiring a 5-digit code that can be set by the operator

• 3 possible settings:

1. Always: ESL is engaged every time the machine is shut off
2. Interval: ESL is engaged after a pre-defined interval of shut off engine
3. Disabled ESL: ESL is not active





# GET THE JOB DONE IN SAFE CONDITIONS



## SAFETY FIRST

### C-Series Minis: no compromise on safety

- **ROPS/TOPS/FOPS:** all C-Series models and version comply with Roll-Over (excluding CX17C)/Tip-Over and Falling Objects -Protective-Structure requirements.
- **Emergency stop switch:** all the models have as a standard feature a switch that immediately stops the engine in case of an emergency.
- **Travel alarm:** an acoustic alarm alerts the people near the machine when it moves forward or backward. This feature is optional on every model.
- **Double-flange rollers:** de-tracking can be dangerous for the operator and the people near the machine. CASE C-Series minis have a double-flange roller design that minimises the risk of de-tracking.
- **Zero Tail Swing (ZTS):** the ZTS design means no risk of hitting obstacles with the rear of the machine when swinging, and creates less obstruction to road traffic.
- **Standard anti-theft:** for a safe storage of the machine, all models are equipped with a standard Engine Start Limit, that, if activated, requires the input of a password to start the machine.
- **Object handling kit (optional):** includes safety valves on boom and arm, lifting hook on bucket linkage, and an overload alarm to handle heavy weights safely (CX26C, CX33C and CX37C).

# C-SERIES MINI EXCAVATORS



## GREAT RELIABILITY: A GIVEN ON CASE EXCAVATORS

World class components and a well-organised plant

- **World class components:** C-Series minis are designed for reliability, components are sourced from the best suppliers on the market and assembled in CASE's Excavator Hub, a World Class Manufacturing production plant. The result: highly reliable machines.
- **Boom and arm reinforced mounting pin:** the pivot pin that holds boom and arm together is a critical point on any excavator. On CASE C-Series the pin is secured from both sides minimising the risk of play between boom and arm.
- **Protected travel motor hoses:** travel motor hoses are well protected inside the track frame.
- **Protected cylinders:** boom, arm, bucket and blade cylinders are well protected with a steel cover.



## EASY AND SAFE SERVICEABILITY

Grouped service points under the hood

C-Series are designed for serviceability:

- Rationalised service points layout
- Convenient check points
- Easy-to-remove side panels for full maintenance and repair access
- Two-piece blade hydraulic hoses



# C-SERIES MINI EXCAVATORS

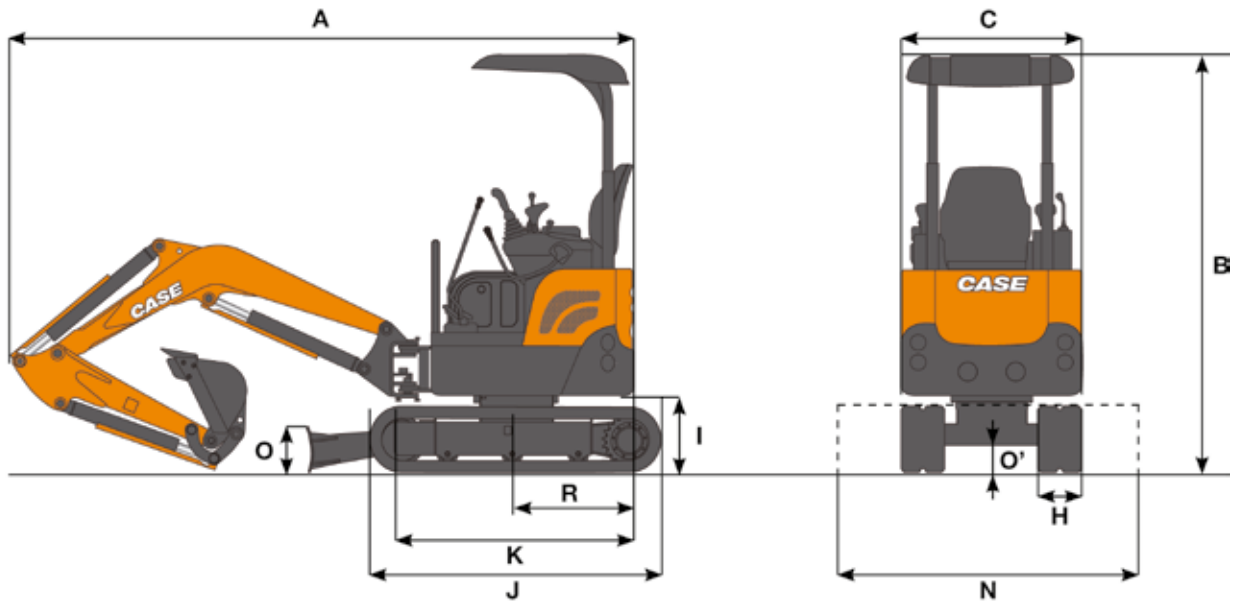

## GENERAL DIMENSIONS

		CX17C	CX26C	CX33C	CX37C
A	Max length (mm)	mm 3480 / 3510*	4030 / 4100*	4640 / 4665*	4790 / 4815*
B	Max height (mm)	mm 2320	2500	2500	2500
C	Max width (mm)	mm 990~1300	1500	1550	1740
R	Rear end swing radius	mm 645	775	775	870
R'	Min front slew radius	mm 1570	1970	2290	2330
H	Track width	mm 230	250	300	300
I	Ground clearance of rear end	mm 440	510	540	540
J	Overall Length of Crawler	mm 1590	1910	2130	2130
K	Center distance of tumbler	mm 1230	1490	1700	1700
L	Blade max lifting	mm 285	330	400	375
M	Blade max lowering	mm 225	380	435	390
N	Blade width	mm 990~1300	1500	1550	1740
O	Blade height	mm 250	300	330	370
O'	Ground clearance of undercarriage	mm 170	290	290	290

\* Long arm

## DIGGING PERFORMANCES

		CX17C	CX26C	CX33C	CX37C
	Dipperstick	mm 960 / 1120	1120 / 1350	1300 / 1600	1300 / 1600
	Dipperstick Breakout force (ISO)	kN 8.5 / 7.6	14.6 / 12.8	19.5 / 16.9	19.5 / 16.9
	Bucket Breakout force (ISO)	kN 15.5 / 15.5	21.1 / 21.1	30.7 / 30.9	30.7 / 30.9
D	Max reach	mm 3900 / 4030	4480 / 4680	5180 / 5470	5315 / 5605
D'	Max reach at ground level	mm 3800 / 3940	4340 / 4540	5060 / 5355	5200 / 5495
E	Max digging depth	mm 2200 / 2350	2420 / 2645	3035 / 3335	3135 / 3440
F	Max dump height	mm 2570 / 2670	2930 / 3030	3275 / 3455	3425 / 3615
G	Max digging height	mm 3580 / 3680	4150 / 4235	4650 / 4840	4810 / 5010

# SPECIFICATIONS

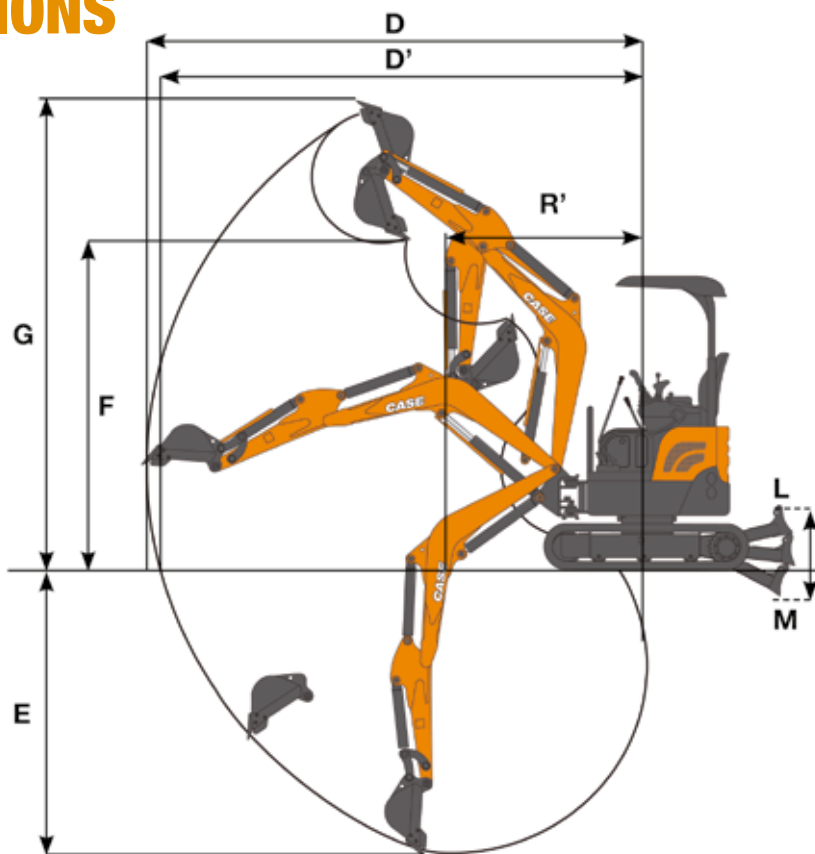

# SPECIFICATIONS

	CX17C	CX26C	CX33C	
<b>ENGINE</b>				
Model	Kubota D902	Kubota D1305	Yanmar 3TNV88F	Yanmar
Displacement (cm <sup>3</sup> )	898	1261	1642	
Rated gross horse power (hp/kW) (ISO 14396) @rpm	16.8 / 12.5 2300	24.8 / 18.5 2400	24.4 / 18.2 2200	2
Max torque (Nm/rpm)	54 / 1900	81 / 1600	94 / 1200	8
Emissions level	Tier 4	Tier 4	Tier 4	
Diesel tank capacity (litres)	17: 20	26: 30	33: 30	
<b>HYDRAULIC SYSTEM</b>				
Variable displacement axial piston pumps				
Pump delivery (l/min)	2 x 18.8	2 x 27.6	2 x 37.4	
Pressure (bar)	210	220	230	
Gear pump delivery				
Pump delivery (l/min)	11.3	19.6	23.1	
Pressure (bar)	170	175	205	
<b>SLEWING &amp; TRAVEL SPEED</b>				
Slewing speed (rpm)	9.5	9.1	9.0	
Boom slewing angle (left/right)	70° / 54°	75° / 50°	75° / 50°	7
Travel Speed - Low (1st) (km/h)	2.1	2.4	2.4	
Travel Speed - High (2nd) (km/h)	4.3	4.5	4.2	
<b>OPERATING WEIGHT</b>				
(includes operator, full fuel tank and one bucket)				
Cab (kg)	-	-	-	
Canopy (kg)	1770	2500	3150	
<b>TRANSPORT FEATURE</b>				
(weight is with full fuel tank, without operator, without bucket)				
Weight (Cab) (t)	-	-	-	
Weight (Canopy) (t)	1680	2410	3050	

\* Long arm



# LIFTING CAPACITIES

## LIFTING CAPACITIES

Lift point height (m)	Arm	LIFT-POINT RADIUS					
		1.5 m		2.0 m		3.0 m	

### CX17C Canopy

Lift point height (m)	kg	LIFT-POINT RADIUS					
		1.5 m		2.0 m		3.0 m	
1.0 m	Blade up			430	430	230	230
	Blade down			*620	460	*400	250
0.0 m	Blade up	*600	*600	390	390	210	220
	Blade down	*600	*600	*820	420	*450	230
-1.0 m	Blade up	630	630	390	390		
	Blade down	1060	680	*720	420		

Lift point height (m)	Arm	LIFT-POINT RADIUS					
		1.5 m		2.0 m		3.0 m	

### CX33C Canopy

Lift point height (m)	kg	LIFT-POINT RADIUS					
		1.5 m		2.0 m		3.0 m	
1.0 m	Blade up	400	290	1320	910	660	480
	Blade down	*730	290	2090*	920	*1000	480
0.0 m	Blade up	380	270	1210	810	610	430
	Blade down	*380	270	*1800	820	*1260	430
-1.0 m	Blade up	370	260	1200	810	590	410
	Blade down	*820	260	*2420	810	*1290	410

Lift point height (m)	Arm	LIFT-POINT RADIUS					
		1.5 m		2.0 m		3.0 m	

### CX26C Canopy

Lift point height (m)	kg	LIFT-POINT RADIUS					
		1.5 m		2.0 m		3.0 m	
1.0 m	Blade up			760	620	400	340
	Blade down			*1690	670	*900	360
0.0 m	Blade up	*840	*840	710	570	380	310
	Blade down	*840	*840	*1700	620	*1100	340
-1.0 m	Blade up	1240	950	710	570	370	310
	Blade down	*1920	1040	*1910	620	*1030	330

Lift point height (m)	Arm	LIFT-POINT RADIUS					
		2.0 m		3.0 m		4.0 m	

### CX37C Canopy

Lift point height (m)	kg	LIFT-POINT RADIUS					
		2.0 m		3.0 m		4.0 m	
1.0 m	Blade up			810	690	520	450
	Blade down			*970	750	*690	490
0.0 m	Blade up	*1320	1190	760	640	500	430
	Blade down	*1320	1320	*1160	700	*700	470
-1.0 m	Blade up	1470	1200	750	630	490	420
	Blade down	*2060	1330	*1140	690	*750	460

### CX37C Cab

Lift point height (m)	kg	LIFT-POINT RADIUS					
		2.0 m		3.0 m		4.0 m	
1.0 m	Blade up			860	730	550	480
	Blade down			*970	800	*690	520
0.0 m	Blade up	*1320	1270	810	690	530	460
	Blade down	*1320	*1320	*1160	750	*770	500
-1.0 m	Blade up	1570	1280	800	680	530	450
	Blade down	*2060	1410	*1140	740	*750	490

CX37C

3TNV

1642

4.4 / 18.2

2200

9 / 1200

Tier 4

All models are equipped with long arm, no bucket, std counterweight, rubber tracks

37: 40 ISO 10567: Lifting capacity does not exceed 75% of tipping load or 87% of full hydraulic capacity.

\* Indicates load limited by hydraulic capacity

2 x 37.4

230

23.1

205

9.5

75° / 50°

2.3

4.4

3760

3620

3660

3520



# BUILDING A STRONG CASE.

Since 1842, at CASE Construction Equipment we have lived by an unwavering commitment to build practical, intuitive solutions that deliver both efficiency and productivity.

We continually strive to make it easier for our customers to implement emerging technologies and new compliance mandates.

Today, our global scale combined with our local expertise enables us to keep customers' real-world challenges at the center of our product development.

The vast CASE dealers' network is always ready to support and protect your investment and exceed your expectations, while also providing you with the ultimate ownership experience.

Our goal is to build both stronger machines—and stronger communities. At the end of the day, we do what's right for our customers and our communities so that they can count on CASE.

**CASECE.com**

NOTE: Standard and optional fittings can vary according to the demands and specific regulations of each country. The illustrations may include optional rather than standard fittings - consult your CASE dealer. Furthermore, CNH Industrial reserves the right to modify machine specifications without incurring any obligation relating to such changes.

Conforms to directive 2006/42/EC

