

5 - TRANSPORT OPERATIONS

Road transport

Loading the machine onto a transport trailer

⚠ WARNING

Transport hazard!

The machine can slip or fall from a ramp or trailer. Make sure the ramp and trailer are not slippery. Remove all oil, grease, ice, etc. Move the machine on or off the trailer with machine centered on the trailer or ramp.

Failure to comply could result in death or serious injury.

W0152A

⚠ WARNING

Improper operation or service of this machine can result in an accident.

Assign a supervisor to direct worksite operations. Agree on all safety measures, procedures, and suitable hand signals.

Failure to comply could result in death or serious injury.

W0287A

Make sure to check the total weight, length, width and height of the machine to be transported. Refer to Chapter 8.

Make sure to use a trailer with a rated capacity and dimensions sufficient to transport the machine. If a rear loading type trailer is used for road transport, make sure that ramps are available to climb onto the trailer bed. Use ramps which have sufficient width, length, thickness and strength. The ramp slope should be **15°** or less.

Investigate beforehand the conditions of the road to be traveled, weight and size limits, and special local traffic regulations. Obtain any permits required from proper government agencies for machine transportation.

Trailer setup

Position the trailer on firm and level ground.

Put blocks to the tires of the trailer to prevent trailer from moving.

If a rear loading type trailer is used for road transport, prepare the loading ramps. If the ramps are included in the trailer frame, lower them to the ground. If the ramps are external to the trailer, match them to the rear edge of the trailer avoiding any bump between trailer bed and external ramps.

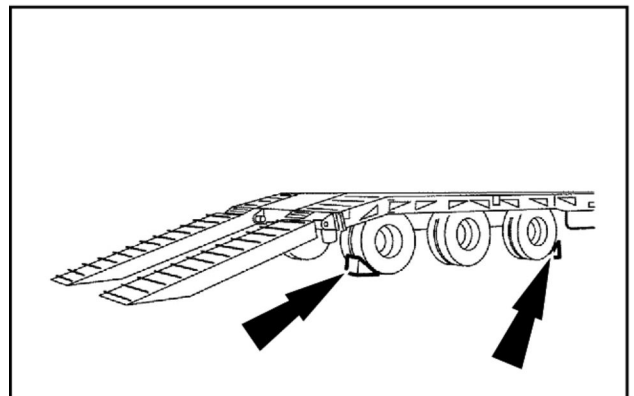

SMIL13CEX2717AB 1

Machine setup

Accurately clean the machine undercarriage and tracks to prevent mud or debris from skidding during transport.

Make sure to deactivate the auto idle function and the auto shut-down function. Press the idle mode button **(1)** until any idle icon on the display turns off.

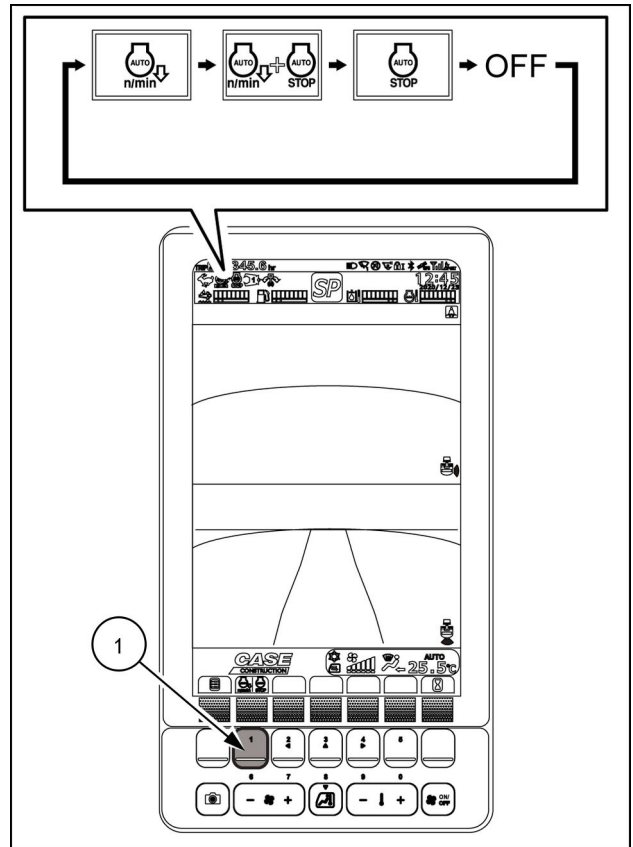

SMIL21CEX3500BA 2

Press the travel mode selector button **(2)** to select the low travel speed. The “Turtle” icon appears on the display.

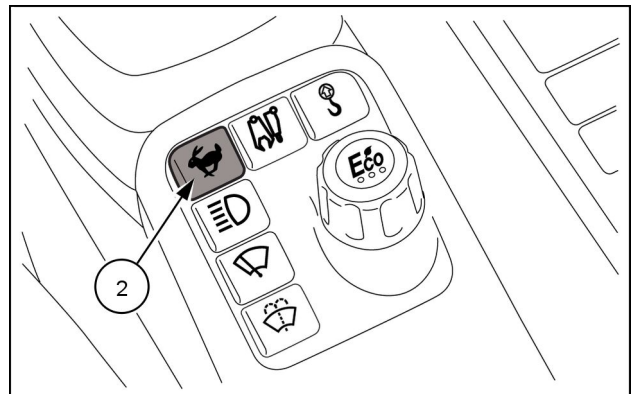

SMIL21CEX3498AA 3

Loading the machine on a rear loading type trailer (with front equipment installed)

If any heavy attachment is fitted on the machine, such as a hydraulic breaker or a hydraulic crusher, remove the attachment before loading the machine onto the trailer. Refer to the Operator's Manual of the attachment, and strictly follow the specific procedure to remove the attachment from the machine.

Select the P work mode.

The recommended practice is to set P8 work mode.

Align the machine to the trailer, so as the travel motors face the trailer ramps.

NOTICE: Starting from this position, the travel control levers must be pulled backward to move on the ramps and on the trailer bed. Confirm the travel control directions before start moving onto the ramps.

Get close to the ramps and operate the arm and bucket controls so that the arm stands vertical and the bottom side of the bucket is about **20 cm (7.9 in)** above the trailer bed.

Slowly climb the trailer ramps keeping the bucket close to the trailer bed. Slowly travel on the trailer bed to reach the resting position, giving particular attention to the attachment so as not to touch the trailer bed.

Slowly turn the upper structure **180°**.

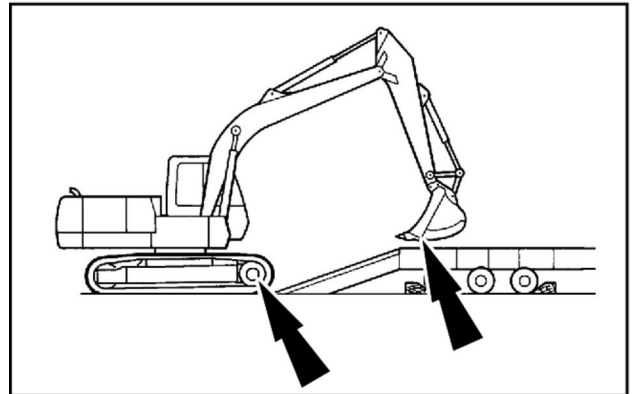

SMIL13CEX2720AB 4

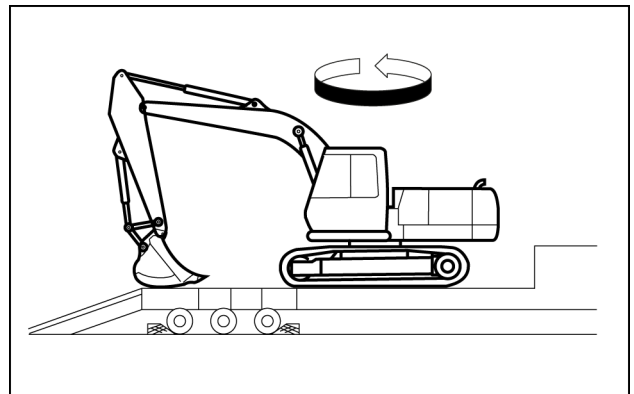

SMIL20CEX0030AA 5

Loading the machine on a rear loading type trailer (without front equipment installed)

⚠ WARNING
Pressurized system!
 Before removing the attachment from the machine, make sure the air pressure and hydraulic oil pressure are at zero.
 Failure to comply could result in death or serious injury.

W0284A

⚠ WARNING
Tip-over hazard!
 The counterweight **MUST** be removed before transporting the machine without an attachment. Consult your dealer.
 Failure to comply could result in death or serious injury.

W0260A

If the machine has to be transported without the complete front equipment (boom and arm), the counterweight should be removed from the base machine. Loading the base machine on the trailer with the counterweight installed affects the stability of the base machine itself, and definitely compromises its climbing ability.

NOTICE: *The use of lifting systems is necessary for removal and installation of the machine front attachment and of the counterweight. Refer to your CASE CONSTRUCTION dealer for proper removal and installation procedure.*

Select the P work mode.

The recommended practice is to set P8 work mode.

Align the machine to the trailer, so as the travel motors face the trailer ramps.

NOTICE: *Starting from this position, the travel control levers must be pulled backward to move on the ramps and on the trailer bed. Confirm the travel control directions before start moving onto the ramps.*

Slowly climb the trailer ramps. Slowly travel on the trailer bed to reach the resting position.

Slowly turn the upper structure **180°**.

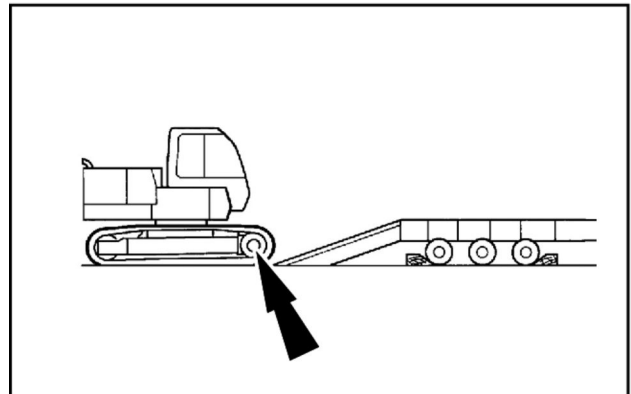

SMIL13CEX2721AB 6

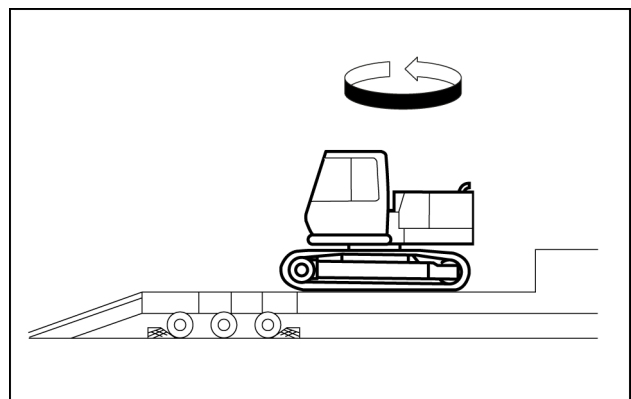

SMIL20CEX0029AA 7

Tie downs for shipping

1. Set the machine in the position for transport: fully retract the arm and curl the bucket slowly.
2. Place the block **(A)** on the trailer floor as show in the picture, and lower the boom slowly until the bucket linkage lays on the block.
3. Check the overall height between the ground and the highest point of the machine and check the overall width of the machine. Make sure to be within the size limits defined before transport, in order to confirm documents and permissions already got to comply to the local traffic regulations.

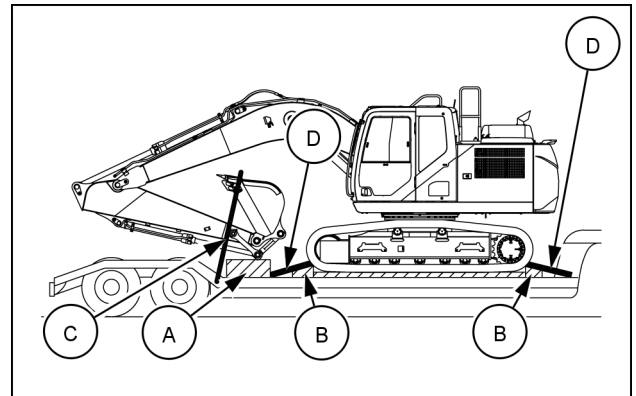

SMIL19CEX2614AA 1

4. Place the gate lock lever in central position. Stop the engine and remove the starter key.
5. Get off the machine. Retract the radio antenna. Fold the rear view mirrors.
6. Lock the cab door and the side panels.
7. Check the condition of the tie-down points on the trailer.
8. Put chocks **(B)** against the edges of the tracks.
9. Pass a wire rope **(C)** around the bucket to secure the front equipment to the trailer.
10. Fix one end of a tie-down chain **(D)** to each of the four lashing points **(E)** identified on the inside of the lower frame.
11. Set the chains in an X shape as shown in the picture, and fix them to the tie-down points on the trailer. Tension the chains evenly to secure the machine to the trailer.
12. Carry out a final check of the tie-down condition.
13. If a rear loading type trailer is used for road transport, lift or remove the loading ramps.
14. Remove blocks from the tires of the trailer.

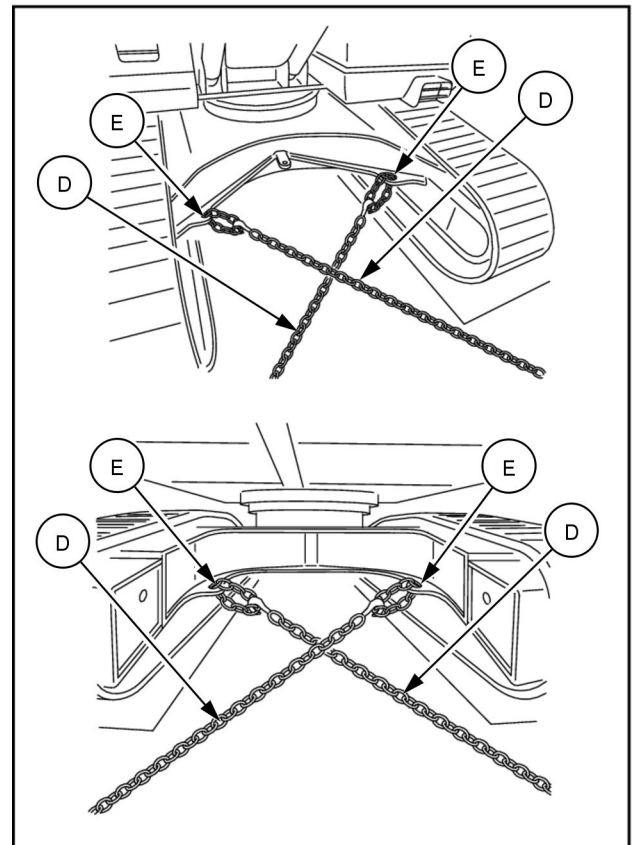

SMIL13CEX2729BA 2

5 - TRANSPORT OPERATIONS

The machine may be further secured onto the trailer bed with a vertical tie-down.

Put pads **(F)** over the tracks in the positions identified along the sides of the lower frame. Route the wire ropes **(G)** across the tracks, and tie-down on the vertical direction.

NOTICE: Make sure not to tie-down the machine only in the vertical direction: the required tie-down force would be high, and this will cause damages to the tracks and to the other traction components.

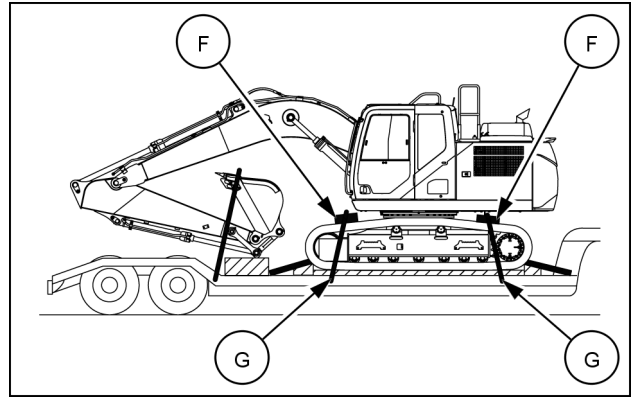

SMIL19CEX2613AA 3

Unloading the machine from a transport trailer

Rear loading type transport trailer

1. Position the trailer on firm and level ground. Put blocks to the tires of trailer to prevent trailer from moving.
2. Remove chains, wire ropes, chocks, blocks and other devices used to secure the machine during road transport.
3. Prepare the loading ramps. If the ramps are included in the trailer frame, lower them to the ground. If the ramps are external to the trailer, match them to the rear edge of the trailer avoiding any bump between trailer bed and external ramps.
4. Get on the machine and start the engine.
5. Make sure to deactivate the auto idle function and the auto shut-down function. Press the idle mode button **(1)** until any idle icon on the display turns off.

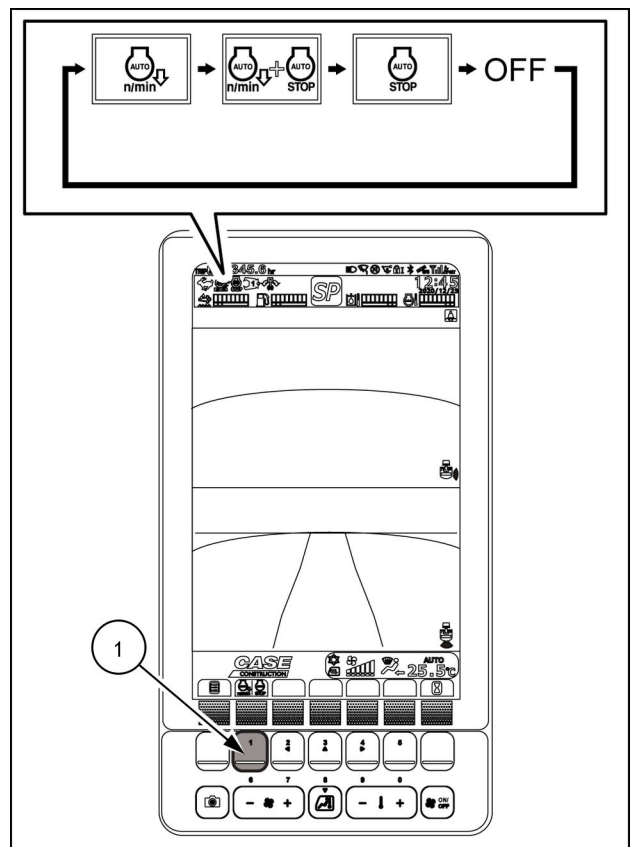

SMIL21CEX3500BA 1

6. Press the travel mode selector button **(2)** to select the low travel speed. The “Turtle” icon appears on the display.

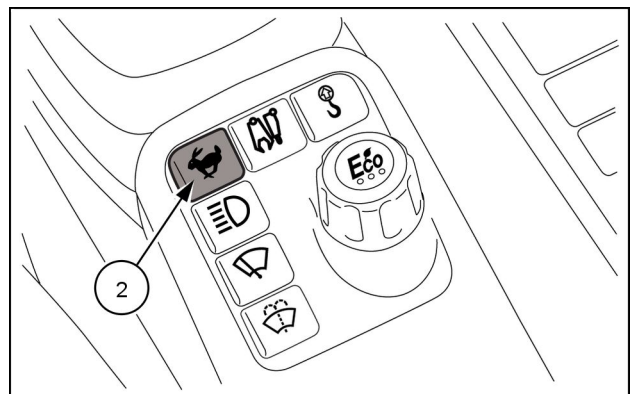

SMIL21CEX3498AA 2

7. Select the P work mode and set the gate lock lever in forward position.

NOTE: The recommended practice is to set (P8) work mode.

8. If the front equipment is installed, operate the arm and bucket controls so that the arm stands vertical and the bottom of the bucket is about **20 cm (7.9 in)** above the trailer bed.

NOTICE: Starting from this position, the travel control levers must be pushed forward to move on the trailer bed and on the ramps. Confirm the travel control directions before start moving.

9. Travel slowly towards the back of the trailer and stop as reaching the ramps. If the front equipment is installed, operate boom and arm softly in order to get the bucket close to the ground ahead of the ramps. Avoid to fully extend the bucket cylinder to prevent damaging it due to accidental impacts with the ground.
10. Move down on ramps with extreme care while operating boom and arm softly in order to keep the bucket close to the ground and so to grant machine stability.
11. Pass through the ramps completely and stop the machine once it gets on the ground.

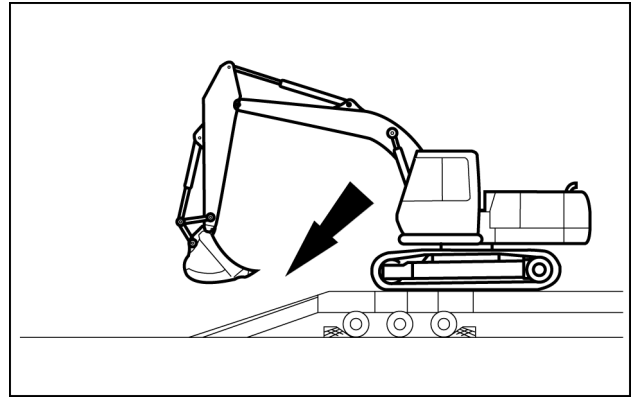

SMIL20CEX0037AC 3

Shipping transport

Lifting the machine with a crane

▲ WARNING

Hazard to bystanders!

ALWAYS make sure the work area is clear of bystanders and domestic animals before starting this procedure. Know the full area of movement of the machine. Do not permit anyone to enter the area of movement during this procedure.

Failure to comply could result in death or serious injury.

W0245A

▲ WARNING

Crushing hazard!

The lifting systems must be operated by qualified personnel who are aware of the correct procedures to follow. Make sure all lifting equipment is in good condition, and all hooks are equipped with safety latches.

Failure to comply could result in death or serious injury.

W0256A

▲ WARNING

Improper operation or service of this machine can result in an accident.

Assign a supervisor to direct worksite operations. Agree on all safety measures, procedures, and suitable hand signals.

Failure to comply could result in death or serious injury.

W0287A

Preparation before lifting the machine

Always lift the machine with the complete front equipment (boom and arm) installed, and fitted with an average size bucket. Never lift the machine fitted with heavy attachments as hydraulic breakers or hydraulic crushers.

NOTICE: *if the machine has to be lifted without the complete front equipment (boom and arm), the counterweight shall be removed from the base machine. Lifting up the base machine with the counterweight installed affects the stability of the base machine during lifting operation.*

Make provision for wire ropes and other lifting devices of proper capacity in order to tackle the machine weight. Refer to Chapter 8 for the machine weights, and always consider **120%** of these reference weights for the selection of the lifting devices.

Refer to the picture on the next page for layout and sizing of the wire ropes and of the other lifting devices to be used. Always make sure to check the machine stability before carrying out the lifting operation.

NOTICE: *As reference guideline, each one of the angles A and B between the wire ropes and the middle of the expander should be preliminary assumed at **15°**. However, these values shall be checked and thus calibrated to tackle the actual machine configuration. The overall angle A+B shall be anyway kept at **30 – 35°**.*

NOTICE: *For lifting of CX190E, the link dimension on the expander shall be increased to **5400 mm (213 in)** and the link angles would have to be decreased to **70°**.*

Make provision for wire ropes and other lifting devices fitted with selflocking hooks in order to avoid unintended opening during lift operation.

Make provision for wire ropes of sufficient length and expander of proper size to prevent interference with the machine body when lifting up the machine. Cover the wire ropes with paddings where they get in contact with the machine frames in order to protect the machine from damaging.

Position the machine on a firm and level ground, and proceed as follows:

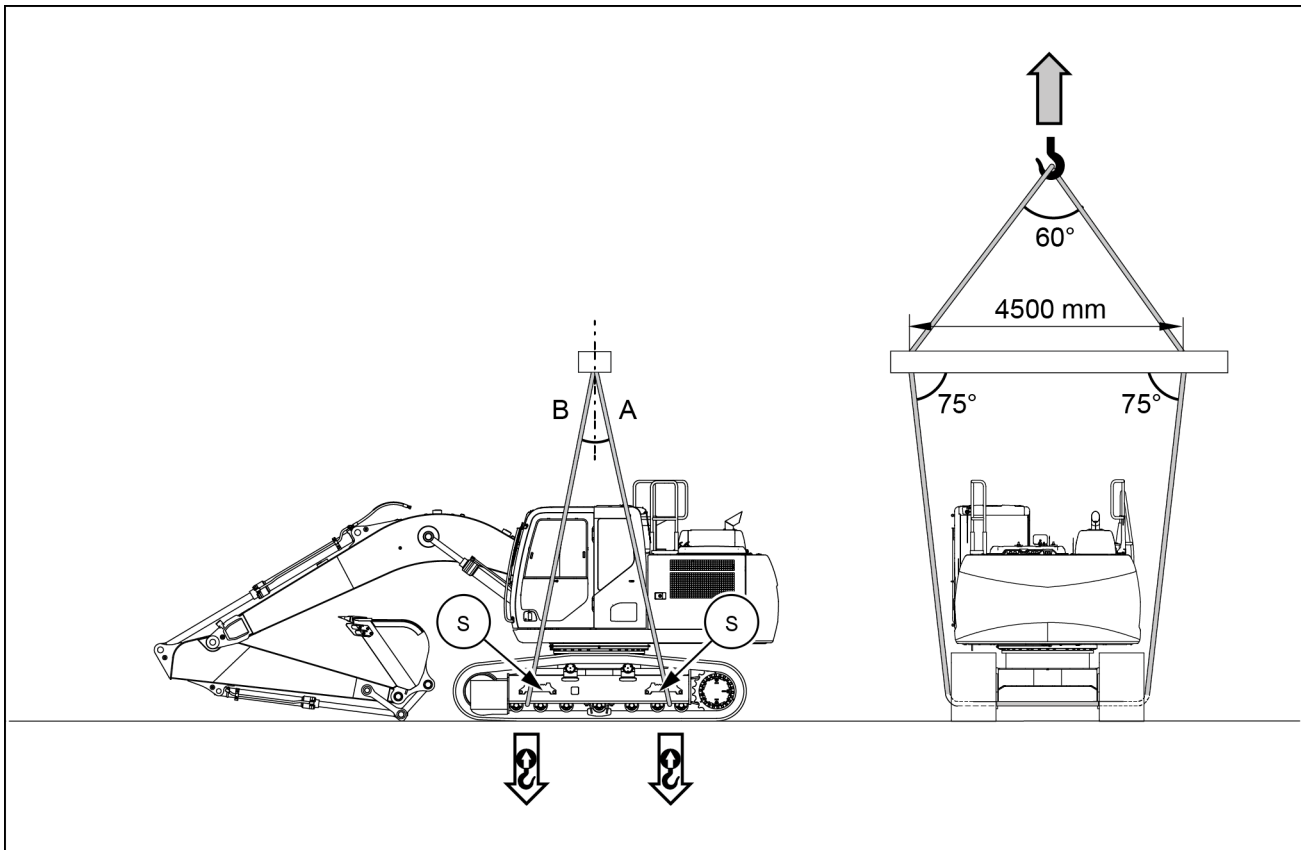

SMIL16CEX0258FA 1

1. Set the machine in the position for transport: fully retract the arm, curl the bucket and lower the boom. Place the gate lock lever in central position. Stop the engine and remove the starter key. Check the operator's compartment for any loose item, tools, etc. that could fall or cause a problem or injury during the procedure and remove or secure them. Get off the machine. Retract the radio antenna. Fold the rear view mirrors. Lock the cab door and the side panels. Remove the four side steps (S).
2. Check for lifting point decals on the undercarriage of the machine in order to know where the wire ropes shall be routed. Pass-through the first wire rope between the first two lower rollers on the front of the machine undercarriage. Pass-through the second wire rope between the two last lower rollers on the rear of the machine undercarriage.
3. Link the front wire rope and the rear wire rope to the expander. Slowly lift the expander to tension the wire ropes in order to reach the layout of the lifting devices shown in figure.
4. Carry out a final check of the linkages on the expander and then start lifting the machine.
5. Lift the machine slowly and vertically and make sure for its stability. If needed, lower the machine to the ground slowly and calibrate the layout of the wire ropes to tackle the actual machine configuration.

NOTICE: The overall angle $A+B$ shall be kept at $30 - 35^\circ$.

6. Complete the vertical lift up to the height of the platform where the machine has to be placed. Slowly move the crane laterally to get the machine right over the platform. Gently lower the machine to the platform.

NOTICE: always avoid sliding movements of the crane (lift and move laterally at the same time). Sliding movements definitely affect machine stability during lifting operation.

Recovery transport

Towing the machine

⚠ WARNING

Hazard to bystanders!

The operator must be the only person on the machine when towing. Make sure that nobody else is on the machine or within its working range.

Failure to comply could result in death or serious injury.

W0259A

⚠ WARNING

Misuse hazard!

Towing is a delicate maneuver that is always carried out at the risk of the user. The manufacturer's warranty does not apply to incidents or accidents that occur during towing. Where possible, carry out the repairs at the site.

Failure to comply could result in death or serious injury.

W0286A

As far as possible try to carry out repairs on spot or consult your CASE CONSTRUCTION Dealer.

NOTICE: the machine must be towed very slowly, over a short distance and only if it is really unavoidable. Always tow the machine in alignment with the undercarriage.

If the machine is bogged down, it must be towed as follows:

1. Make sure that it can be towed without risk of further damage.
2. Make sure that the shackles, chains and tackle are in perfect condition and strong enough to move the load.
3. Attach the shackles, chains and tackle to the undercarriage taking care to protect any salient angles.
4. Pull the machine without jerking, very slowly and in alignment with the undercarriage.

Towing a load

To tow a load of up to **10 t (22046 lb)**, use one of the towing holes provided for this purpose.

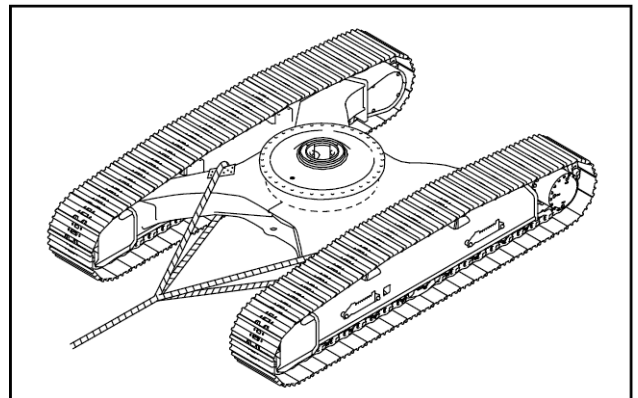

SMIL13CEX2731AA 1

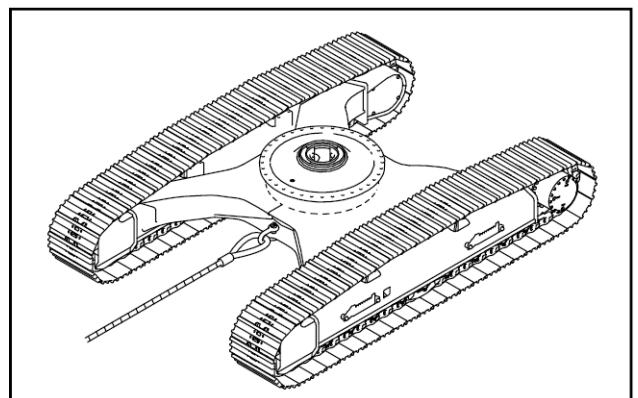

SMIL13CEX2732AA 2

