

C337

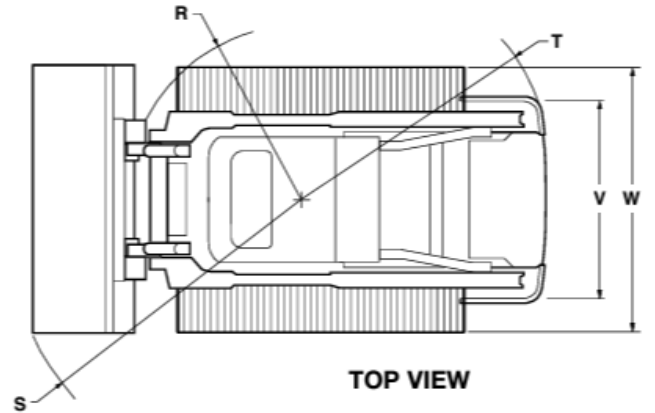
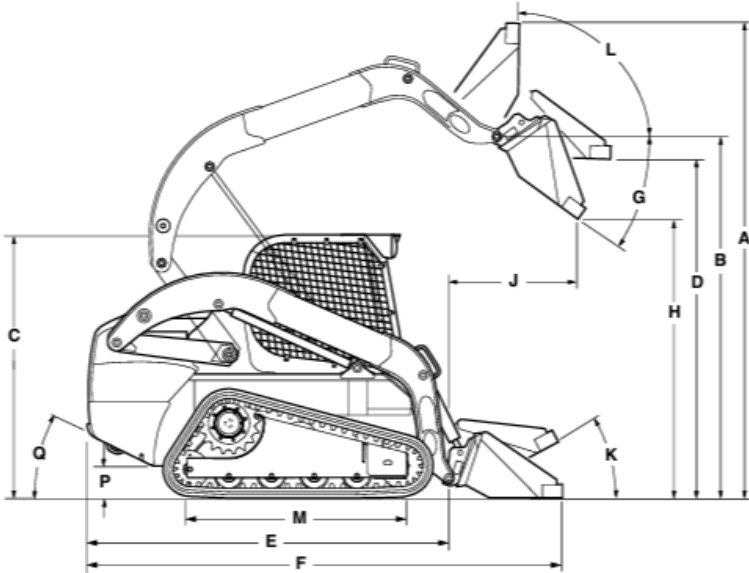

DIMENSIONS			
Overall operating height			
A	with foundry/excavating bucket short	in (mm)	160.2 (4068)
A	with low profile/standard bucket	in (mm)	164.4 (4176)
A	with low profile extended/long bucket	in (mm)	169.2 (4298)
Height to			
B	Bucket hinge pin	in (mm)	131.1 (3330)
C	Top of ROPS	in (mm)	80.4 (2043)
D	Bottom of level bucket, fully raised	in (mm)	123.0 (3125)
Overall Length			
E	without attachment with coupler	in (mm)	117.0 (2972)
F	with foundry excavation bucket on ground	in (mm)	141.1 (3592)
F	with low profile bucket	in (mm)	146.7 (3727)
F	with low profile extended bucket	in (mm)	150.5 (3823)
Dump			
G	Dump angle	degrees	55
H	Dump height		
	with foundry/excavating bucket short in (mm)	in (mm)	104.5 (2655) @ 45°
	with low profile/standard bucket	in (mm)	101.6 (2581) @ 45°
J	Dump reach (max height)	in (mm)	37 (941) @ 45°

Maximum attachment rollback			
K	Bucket on ground	degrees	33
L	Bucket at full height	degrees	85
Track and clearance			
M	Track on ground	in (mm)	64.5 (1639)
P	Ground clearance (bottom of belly pan)	in (mm)	9.6 (244)
Q	Angle of departure	in (mm)	32
Clearance circle			
R	Without bucket	in (mm)	56.2 (1482)
S	With foundry bucket in carry position	in (mm)	86.6 (2200)
S	With low profile bucket on ground	in (mm)	90.4 (2297)
S	With extended low profile bucket on ground	in (mm)	94.8 (2409)
T	Clearance circle rear	in (mm)	67 (1702)
V	Track gauge	in (mm)	58.6 (1488)
W	Overall width	in (mm)	76.5 (1943)
ENGINE			
Manufacturer/model			FPT / F5BFL463A*G001
Type			Diesel 4-stroke, turbo, D.I.
Bore/stroke	in (mm)		3.9 x 4.3 (99 x 110)
Displacement	in ³ (L)		207 (3.4)
Fuel injection			HPCR Direct
Fuel			#2 diesel
Fuel filter			Pre-filter 99.8% @ 30 microns, Main filter 95% @ 4 microns
Air intake			Turbocharged Aftercooled with external EGR
Cooling			Liquid
Engine Speeds			
High idle - no load		rpm	2500 +/- 25
Rated - full load		rpm	2500
Low idle		rpm	1150 +/- 25

Horsepower per SAE J1349		
	Gross hp (kW)	74 (55) @ 2500 rpm
	Net hp (kW)	68 (51) @ 2500 rpm
Peak torque	lb-ft (N•m)	232 (314) @ 1400 rpm
POWER TRAIN		
Drive pump electro hydraulic		
Pump to engine ratio		1:1
Displacement	in ³ (L)	2.75 (45)
Flow	gpm (lpm)	28.8 (109)
Charge pressure	psi (bar)	362 (24.5)
System relief	psi (bar)	5220 (360)
Control		Mechanical or Electro hydraulic
Drive Motors		
Effective max displacement	in ³ (cc)	3.10 (50.9)
Effective Displacement opt high speed	in ³ (cc)	-
Speed @ high idle engine	rpm	103
Speed @ optional high speed	rpm	156
Torque @ max displ. and relief pressure	lb-ft (N•m)	4654 (6310)
Travel Speed		
Low range	mph (km/h)	5.5 (8.9)
High range	mph (km/h)	8.0 (12.9)
Final drive	mph (km/h)	Planetary gearbox with 2-speed motor
Parking Brake		
Type		Spring applied, hydraulic release disc
Engagement		Depress on/off brake button on instrument panel, disconnect lapbelt, get off seat, or stop engine
UNDERCARRIAGE		
System		Zig Zag Pattern
Idlers / rollers per side		2/4
Ground Pressure		
PSI (with spec belt)		4.2

HYDRAULIC SYSTEM		
Pumps		
Type		Gear
Displacement standard aux.	in ³ (cc)	2.23 (36.6)
Displacement high flow aux.	in ³ (cc)	1.24 (20.4)
Standard pump flow	gpm (Lpm)	24.2 (91.5)
Optional high flow	gpm (Lpm)	37.6 (142.5)
Enhanced high flow	gpm (Lpm)	NA
Loader control valve		
Type		3 spool / open center / series
Standard relief pressure	psi (bar)	3,046 (210)
Enhanced high flow relief pressure	psi (bar)	NA
Hydraulic filter		6 microns / spin on
CYLINDERS		
Lift Cylinder		
Bore diameter	in (mm)	2.75 (69.85)
Rod diameter	in (mm)	1.75 (44.5)
Stroke in	in (mm)	34.9 (886.5)
Closed length	in (mm)	47.4 (1205)
Bucket Cylinders		
Bore diameter	in (mm)	3.0 (76.2)
Rod Diameter	in (mm)	1.5 (38.1)
Stroke in	in (mm)	16.14 (410)
Closed length	in (mm)	24 (610)
Rated Operating Load		
50% tip	lbs. (kg)	3700 (1678)
35% tip	lbs. (kg)	2590 (1178)
Tipping load	lbs. (kg)	7400 (3357)
Breakout Forces		
Lift cylinder	lbs. (kN)	6110 (27.2)
Bucket cylinder	lbs. (kN)	7360 (32.7)

Cycle Times		
Raise	sec	4.5
Lower	sec	2.6
Dump	sec	2.6
Roll back	sec	2.0
Loader control valve		
Type		-
Standard relief pressure	psi (bar)	-
Enhanced high flow relief pressure	psi (bar)	-
Hydraulic filter		-
WEIGHTS		
Operating weight	lbs (kg)	9945 (4520)
Shipping weight	lbs (kg)	9615 (4370)
SERVICE CAPACITIES		
Fuel tank, gal (L)		25.5 (96.5)
Engine oil with filter, qt (L)		8.9 (8.5)
System Capacity with filter, qt (L)		47 (44.5)
DEF tank, gal (L)		NA