

LRZ

Loaders



CASE IH
AGRICULTURE

- ▶ **Best visibility.** New "Z" levelling kinematics within liftarm profile, protected piping and modular hydraulic valve block for best view.
- ▶ **Optimum ergonomics, great comfort.** Either seat mounted controls or integrated into the cab's array of controls within easy reach.
- ▶ **Multi Quick Coupler as standard.** (excluding LRZ 95) Single point connection - No oil leakage. Fast, clean and tidy - No need for gloves.
- ▶ **Fast attach system.** Rapid loader attachment without tools.

CASE IH LRZ LOADERS - LOADING IS ABOUT TO BE MEASURED ON A NEW SCALE.



Rapid bucket discharge (+ models). Quick dump for greater productivity and reduced operator effort.

Bucket angle. Outstanding bucket angle for greater productivity. "+"-models over 24° degree additional scooping.

Shock absorbers. Loader arm suspension. Greater comfort and stability.

Service accessibility. Excellent maintenance access with loader fitted. Perfect design and bracket positioning.

LRZ LOADER – MEANS BUSINESS

CASE IH WANTS YOU TO REAP MAXIMUM PRODUCTIVITY FROM YOUR INVESTMENT. THE NEW CASE IH LRZ FRONT LOADERS COMBINE POWER, RIGIDITY, LOADING PERFORMANCE AND MODERN DESIGN TO FORM AN INNOVATIVE LOADER CONCEPT. THESE LOADERS EXCEL IN FUNCTIONALITY AND FEATURE TECHNICALLY INTELLIGENT SOLUTIONS TO GIVE YOU PLEASURE IN YOUR DAILY WORK BY DELIVERING HIGH PERFORMANCE AND COMFORTABLE HANDLING.

Outstanding loader performance. The Case IH LRZ front loader provides outstanding lift capacity and maximum lift height, with excellent crow and dump angles. The LRZ Series has also been engineered to provide the highest levels of operator comfort and ease of control. Performance is however not just a function of comfort and responsive controls. Case IH tractors come equipped with spectacular manoeuvrability features such as Powershuttle and a really tight turning circle. Literally, Case IH tractors and Series LRZ loaders are made for each other.

Order your Case IH tractor loader-ready. Then the loader tower mountings and hydraulic piping are installed on the tractor assembly line. These loaders can also be retro-fitted to provide you with a durable and versatile implement matched to the performance of your Case IH tractor.

Full range of buckets and tools. You can match your LRZ loader with the right tool for the job. With earth buckets, manure forks, grapple buckets, silage forks, bale forks, wrapped bale handlers and pallet forks (to mention a few), you can choose the LRZ tools for precisely the tasks you have in mind.

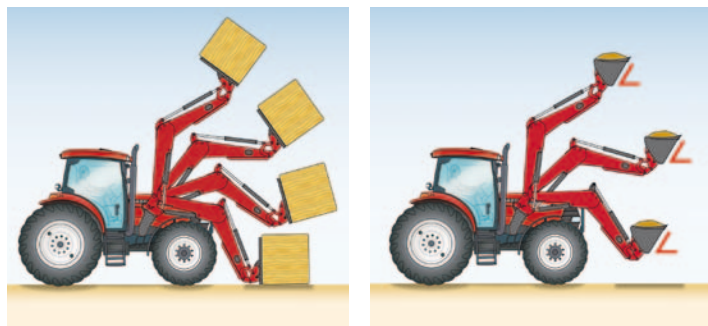

◀ **Case IH LRZ loader range.** Five loader arm models, each available in two versions to match your requirements.

From the left:

NS (Non self-levelling)

MS (Mechanical self-levelling system)

| Model | Max. lift capacity | Max. height at pivot |
|------------------------|--------------------|----------------------|
| | [kg] | [mm] |
| Case IH LRZ 95 | 2060 | 3740 |
| Case IH LRZ 100 | 2540 | 3740 |
| Case IH LRZ 120 | 2300 | 4070 |
| Case IH LRZ 130 | 2640 | 4070 |
| Case IH LRZ 150 | 2800 | 4260 |

▼ Z-Kinematik for outstanding loading performance.

▼ Unobstructed view for the tractor-driver to the loading material and the driveway.

▶ LRZ loader made of fine grain steel for highest rigidity.

▶ Compact combination of loader and tractor.



THE INTELLIGENT, TECHNICAL SOLUTION FOR OPTIMUM VIEW.

Z-KINEMATIK IS THE INNOVATION THAT MAKES ALL THE DIFFERENCE ON A NEW LRZ FRONT LOADER. MECHANICAL SELF-LEVELLING IN ASSOCIATION WITH THE Z-KINEMATIK CONCEPT WAS AVAILABLE BEFORE, BUT THE POSITIONING OF THE CONTROL ROD INSIDE THE REAR LIFT-ARM PILLAR IS A SKILLFUL, CREATIVE SOLUTION THAT DELIVERS PREVIOUSLY UNKNOWN LEVELS OF COMFORT WITH AN IMPROVED VIEW DURING LOADER WORK AND ENHANCED LOADER CONSTRUCTION.

Z-Kinematik. This new concept alleviates the operator's work because conventional self-levelling loaders required the operation of a hydraulic guidance system. This advanced design - doing away with control-rods at the top end - gives you better visibility of the loading material and work area to the front and to the side. This adds up to safer and faster loading. In addition, the Z-Kinematik system provides higher performance in relation to lifting capacity. The result is an enormously powerful front loader you can rely on which is extremely satisfying to use.

Outstanding loading performance by compact combination of tractor and loader. The design of the Z-Kinematik with the control rods inside the rear lift arms works to give the ideal positioning of loader to tractor. Thanks to the absence of an overhead control rod, the loader is placeable closer to the cab, so the front axle load is reduced, resulting in lower wear and higher durability on your tractor.

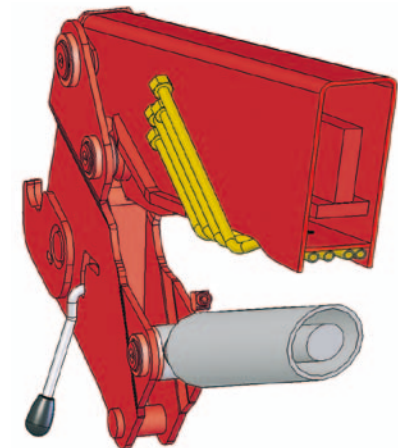

◀ **A loader you can rely on at all times.** All loaders are made of fine-grained, highest quality steel, which gives the front loader rocker the enormous stability and robustness, you expect from a loader of this quality. Hence Case IH still uses fine-grained steel for the LRZ series. The design of interleaved lift arms ensures highest rigidity especially by additional strengthening of the overlapping zone with a thick flange-like part.

▲ **Novel U-pillar-profile with bridge.** The sculpted pillar is made using a single plate stabilized by an internal bridge. The inboard control rod passes through an opening in the bridge plate, while all hydraulic piping is concealed inside the lower section of the pillar.

- ▶ **Protected hydraulic pipes** run invisible.
- ▶ **Central hydraulic device** is compactly placed behind the cross-tube.

- ▼ **Great plus for service amiability.** With few handle the cover plate guard is demounted and all hydraulic pipes are easily accessible.

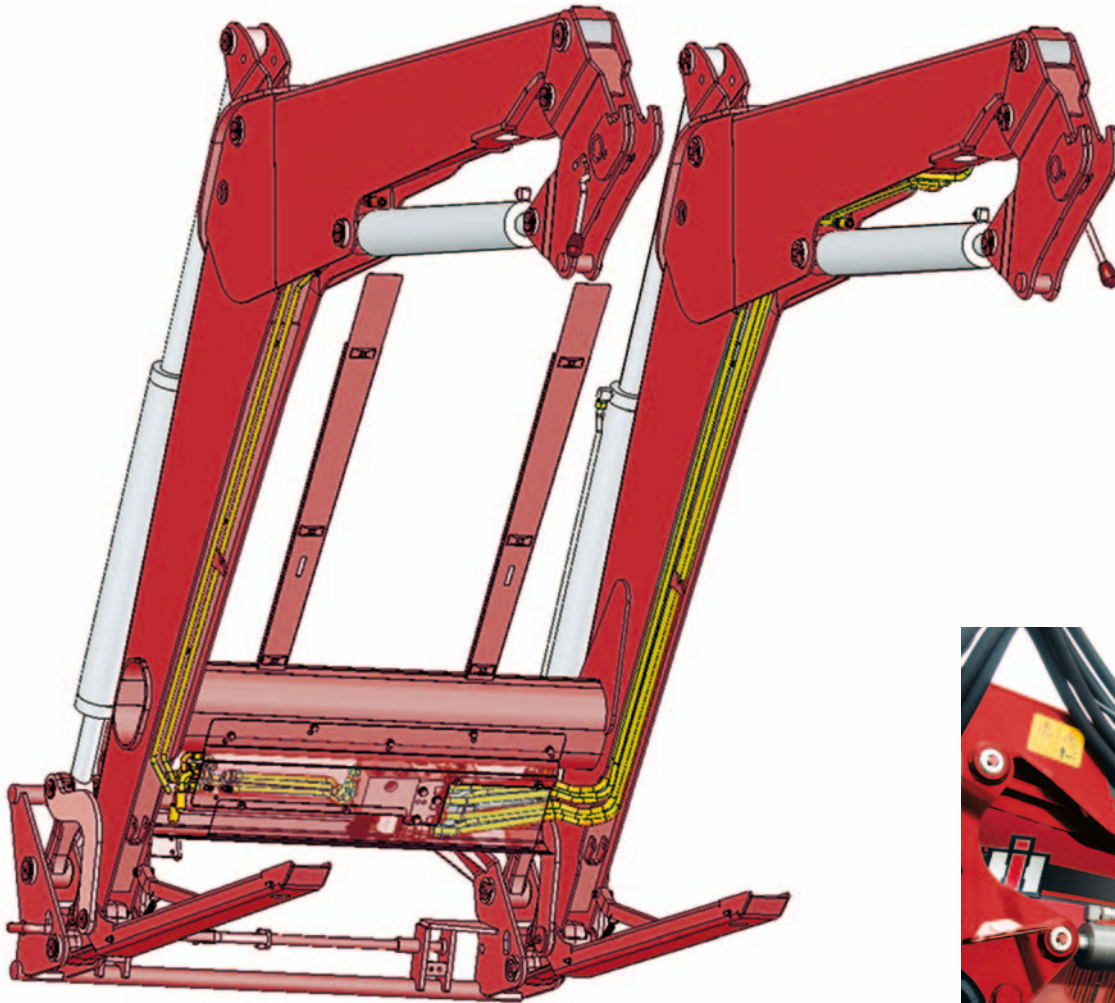

- ▶ **A 3rd and 4th remote*** can be provided for implement function (bale grabber etc.)
- ▶ **Comfort Drive** - Loader arm suspension for a smooth ride.
- ▲ **Plane interior.** Hydraulic pipes are placed underneath the pillars to avoid damaging or even breaking it away.
- ▲ **Parking space.** Case IH kept everything in mind – when you park your loader, you can safely fix the hydraulic tubes, the Hydro-Fix and electric powered plug in a designated carrier.

HYDRAULIC PIPING AND DEVICES

CASE IH LRZ HYDRAULIC - SMART SOLUTIONS IN DETAIL.

WITH THE NEW CASE IH LRZ LOADERS NEARLY EVERY FEATURE HAS EITHER BEEN ENTIRELY RE-DESIGNED OR UPGRADED IN DETAIL. HYDRAULIC PIPES ARE CONCEALED FROM VIEW WHILE STILL BEING EASILY ACCESSIBLE AND THE CENTRAL HYDRAULIC BLOCK IS LOCATED BEHIND THE CROSS-TUBE.

Masked run hydraulic pipes. To run the metal pipes in protected recesses underneath the liftarm is simply ingenious, logical and practical for several reasons. A demountable guard protects the pipes against damage so the good looks are more than just cosmetic. Case IH gives you the great advantage you deserve with this solution, because all pipes - especially connections and fittings - remain accessible at all times and at less operating expense.

Central hydraulic device - compact unit. The central hydraulic block with additional modules is compactly placed at the optimum location behind the cross-tube. Here it does not obstruct the forward view to the loader and material. The whole hydraulics system is masked against dirt and damage by a rigid cover sheet. A double-action pressure limiting valve (DBV), which responds at 210 bar, protects the hydraulic cylinders against overloading on heavy-duty loading jobs.

COMFORT-DRIVE - a new solution for the damping system. The overpressure-sensitive rubber-membrane-accumulators are replaced by a nearly indestructible piston accumulator. This is integrated in the sized dimensioned cross-tube. At maximum load the piston accumulator runs on a stopper and is therefore almost indestructible. With a large volume of about 1l and a low charging pressure this system already damps at small loads. Furthermore the piston accumulator can be charged for higher pressure by appropriate specialist dealers.

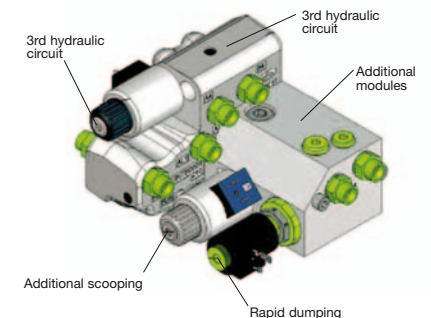
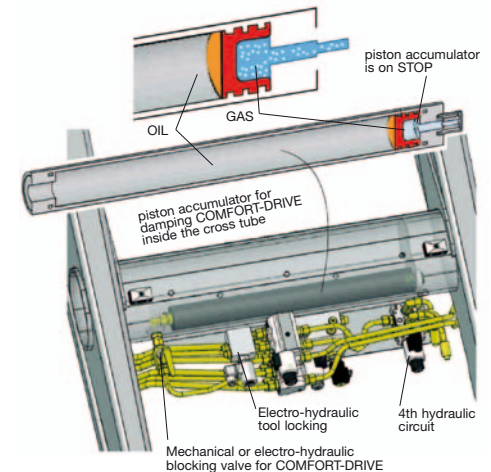

*) to comply with legislation and specifications in your country.

▲ The 3rd control circuit* is prepared in central hydraulic block.

▼ **Easy loader connection.** Drive the tractor between the loader arms...



▼ ...hook up the LRZ Fast Attach coupling...

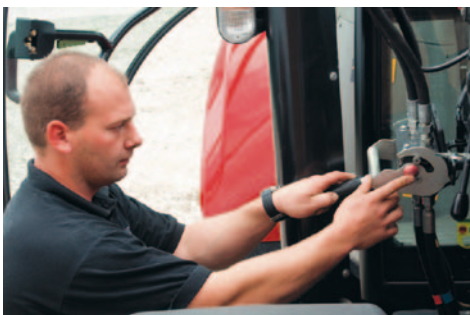

▼ ...raise the loader to engage the hooks, lock in place, fold up the parking stand - and away you go.



CONNECTION AND FUNCTIONALITY

CASE IH LRZ LOADERS. PRECISE, FAST AND EASY.

Fast Attach system. Fitting and removing the Series LRZ loader takes a matter of seconds; Case IH uses a unique fast attach system. Drive the tractor into the parked front loader arms. The coupling sections slip smoothly into the solid drop forged attachment hooks. Connect the hydraulic and electric systems with the single point Multi Quick coupler. Lift the loader arms to engage the hooks. Lock the towers and the arms together using the side handles. Fold up the self-adjusting stands and away you go.

Integrated loader controls. The loader is part of the tractor and not a retrofit as offered by other manufacturers. On Case IH tractors controls are smartly integrated into the seat ensuring the right-hand controls remain unobstructed. The joystick features an additional pushbutton for a third hydraulic connection for operating grapples and grabs etc. The mid-mount valves and couplers are ready-fitted to the tractor and pipe routing is designed to take the shortest path for the most responsive loader performance you will ever experience.

▼ Maxxum and Puma tractors equipped with an LRZ loader feature a seat mounted joystick.



▼ **The “+” plus functions:** - Rapid dumping for a quick bucket discharge (NS and MS models).

▼ - 24° additional scooping for high loading performance (MS models).

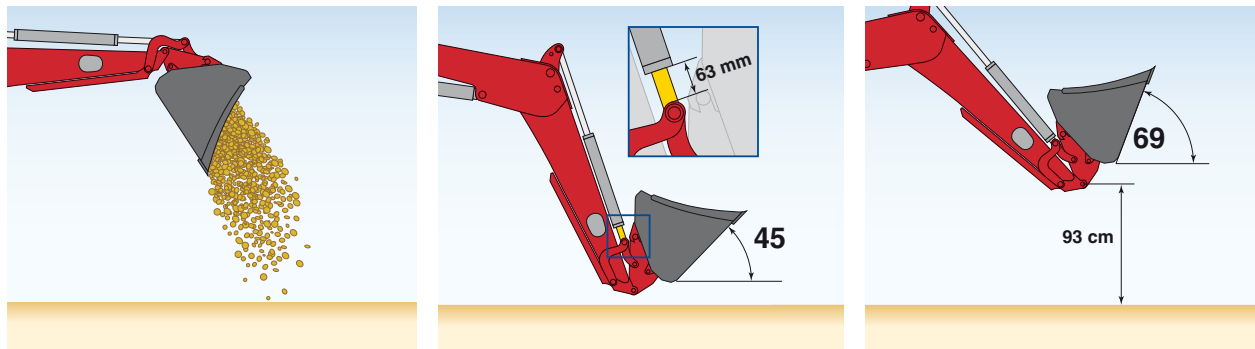

OUR SYSTEMS APPROACH

When you buy a Case IH machine, you can be sure not only that you're buying the best product, but also that you've got the best dealer back-up behind you. Case IH dealers can offer advice on selecting and financing the right machine, will ensure they deliver what you need when you need it, and will then continue to back you and your equipment with the service and spare parts backing you'd expect from a name as trusted as Case IH.



ALL THE PARTS AND SERVICE TO KEEP YOUR EQUIPMENT RUNNING

Find the full line of Case IH parts and components at your local dealer. Plus full service maintenance programmes and industry-leading warranties. It's expertise applied by skilled, factory-trained service professionals committed to providing you maximum uptime, season after season.



00800 227344 00 • 00800 CASE IH 00

AROUND THE CLOCK. AROUND THE COUNTRY

Case IH Max Service is a customer support service that provides 24-hour, seven-day-a-week access to the people, products, and parts support needed to keep your operation running during the times most critical to your profitability. Max Service backs up your dealer with every resource available to Case IH, to help maximize uptime and productivity of Case IH equipment and increase your return on investment through access to product experts and 24/7 Emergency Breakdown Assistance.



OFFERING FINANCING SOLUTIONS FOR MORE THAN 50 YEARS

CNH Capital's extensive experience in the agricultural industry has created a deep understanding of your unique needs. Competitive equipment financing with flexible payments can reduce upfront payments with operating and finance leases. For other needs choose from credit cards specific to the agricultural industry. We can even help you finance crop-input products or land rental. There are financing options that fit the way you farm. CNH Capital helps you find them.

**VISIT OUR FANSHOP AT
WWW.CASEIHSHP.COM**



| LRZ LOADERS | LRZ 95 | LRZ 100 | LRZ 120 | LRZ 130 | LRZ 150 |
|---|-------------|-------------|-------------|-------------|-------------|
| Q1 Max. lift capacity at lower arm pivot point [kg] | 2060 | 2540 | 2300 | 2640 | 2800 |
| Q2 Max. lift capacity at upper arm pivot point [kg] | 1540 | 1900 | 1760 | 2030 | 2280 |
| N1* Payload lower arm - NS/NS+ / MS/MS+ [kg] | 1750 / 2060 | 2170 / 2540 | 1990 / 2300 | 2280 / 2640 | 2460 / 2800 |
| N2* Payload upper arm - NS/NS+ / MS/MS+ [kg] | 1280 / 1540 | 1590 / 1900 | 1500 / 1760 | 1720 / 2030 | 1930 / 2280 |
| R Max. break-open force bucket edge - NS/NS+ / MS/MS+ [kg] | 1710 / 2600 | 2170 / 2600 | 2390 / 2600 | 2390 / 2850 | 2390 / 3400 |
| Weight without tool and attached parts - NS/NS+ / MS/MS+ [kg] | 420 / 465 | 425 / 475 | 470 / 540 | 480 / 550 | 540 / 680 |
| H Max. height at pivot [mm] | 3740 | 3740 | 4070 | 4070 | 4260 |
| L Loading height edge blade parallel [mm] | 3530 | 3530 | 3860 | 3860 | 4050 |
| A Loading height edge blade tilted [mm] | 2690 | 2690 | 3010 | 3010 | 3210 |
| B Loader height [mm] | 1780 | 1780 | 1930 | 1930 | 1930 |
| W Reach, bucket tilted [mm] | 700 | 700 | 785 | 785 | 785 |
| S Digging depth [mm] | 210 | 210 | 210 | 210 | 210 |
| Min. tractor power [kW/hp(CV)] | 51 / 70 | 51 / 70 | 66 / 90 | 66 / 90 | 88 / 120 |
| Max. tractor power [kW/hp(CV)] | 73 / 100 | 81 / 110 | 88 / 120 | 103 / 140 | 132 / 180 |

RECOMMENDATIONS

| LRZ LOADERS | LRZ 95 | LRZ 100 | LRZ 120 | LRZ 130 | LRZ 150 |
|---------------|--------|---------|---------|---------|---------|
| JX 70 | ● | - | - | - | - |
| JX 80 | ● | - | - | - | - |
| JX 90 | ● | - | - | - | - |
| JX 95 | ● | - | - | - | - |
| Farmall 75 C | ● | - | - | - | - |
| Quantum 75 C | ● | - | - | - | - |
| Farmall 95 U | - | ● | ○ | - | - |
| Farmall 105 U | - | ○ | ● | - | - |
| Farmall 115 U | - | ○ | ● | - | - |
| Maxxum 110 | - | ● | ○ | - | - |
| Maxxum 120 | - | ○ | ● | - | - |
| Maxxum 130 | - | ○ | ● | - | - |
| Maxxum 115 | - | - | ● | - | - |
| Maxxum 125 | - | - | ○ | ● | - |
| Maxxum 140 | - | - | - | ○ | ● |
| Puma 130 | - | - | ○ | ● | ○ |
| Puma 145 | - | - | ○ | ○ | ● |
| Puma 160 | - | - | - | - | ● |

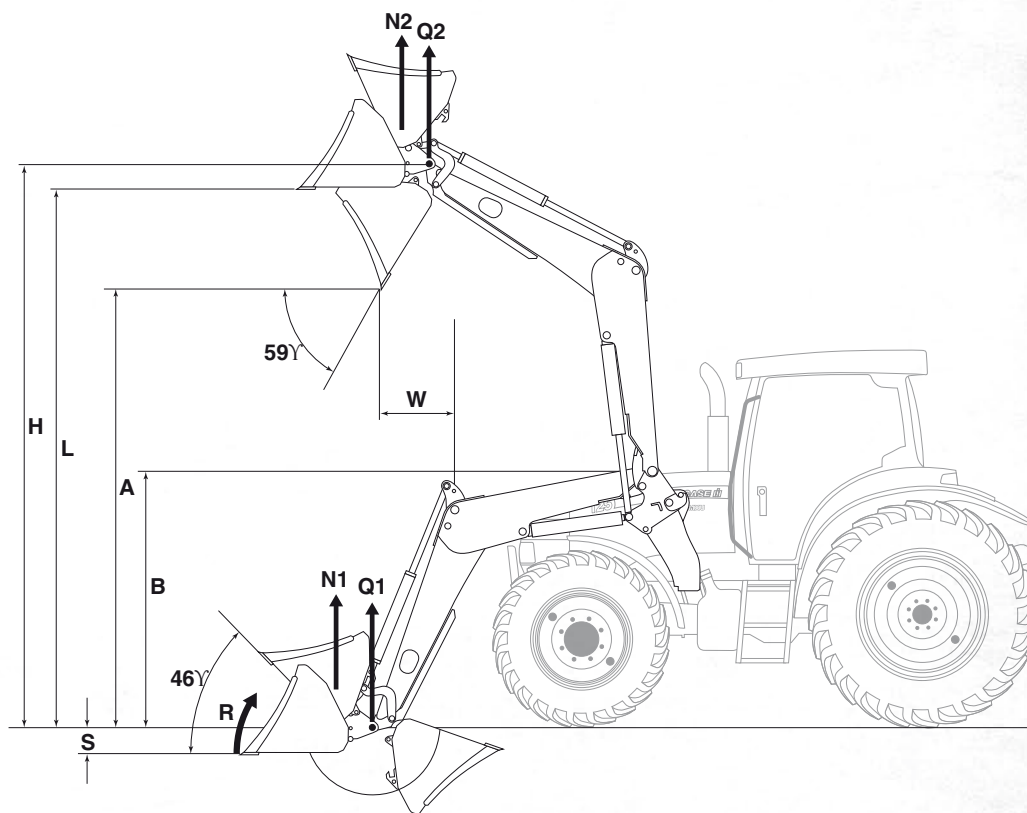

Safety never hurts! Always read the Operator's Manual before working with any equipment. Inspect equipment before using it, and be sure it is operating properly. Follow the product safety signs, and use any safety features provided. This literature has been published for worldwide circulation. The standard and optional equipment and the availability of individual models may vary from one country to the next. Case IH reserves the right to undertake modifications without prior notice to the design and technical equipment at all times without this resulting in any obligation whatsoever to make such modifications to units already sold. Whilst every effort is made to ensure that the specifications, descriptions and illustrations in this brochure are correct at the time of going to press, these are also subject to change without prior notice. Illustrations may show optional equipment or may not show all standard equipment. Case IH recommends **AKCELA** lubricants. CNH UK Ltd., Cranes Farm Road, Basildon, Essex SS14 3AD - © 2012 CASE IH - www.caseih.com - LRZ Loaders-UK-BR - Free phone 00800 22 73 44 00 - Printed in Italy - 10/12 - TP01 - Cod. 9C0005/INB



www.caseih.com