

B90C - B100C - B110C - B115C - BACKHOE LOADERS



**YOUR PERFORMING
PARTNER**



NEW C SERIES, IN-BUILT VERSATILITY

The new C series backhoe loaders from New Holland represent a huge step forward in operator comfort and productivity. The new cab design delivers an enhanced operator experience and increased productivity, with 10% more space and vastly improved clearance when sniveling the seat for backhoe operation, new rear side windows and hugely improved in-cab storage capacity. New Holland backhoe loaders are your versatile choice for loading, grading, grabbing, lifting, excavating, digging, planting, post hole boring and, much more. You have ample choice of loader and backhoe specifications. The 4.5 litre turbocharged engines for the new machines are provided by FPT Industrial, a world-wide leader in the design, production and sale of powertrains for industrial applications. The new C Series will be an asset for the many operations needing a loader with its excellent versatility. It is ideal for a variety of applications other than moving bulk materials, including grading and levelling, grabbing heavy objects such as tree trunks or concrete pillars, and has the traction and power to move heavy materials and objects.

Lower cab noise level

Wider cab frame for improved
visibility and leg room

FPT Engine 4.5L

SLA Straight Arm or
TC Tool Carrier front loader

Excellent serviceability with
one sided service access

Up to 3.5 tonnes
lifting capacity

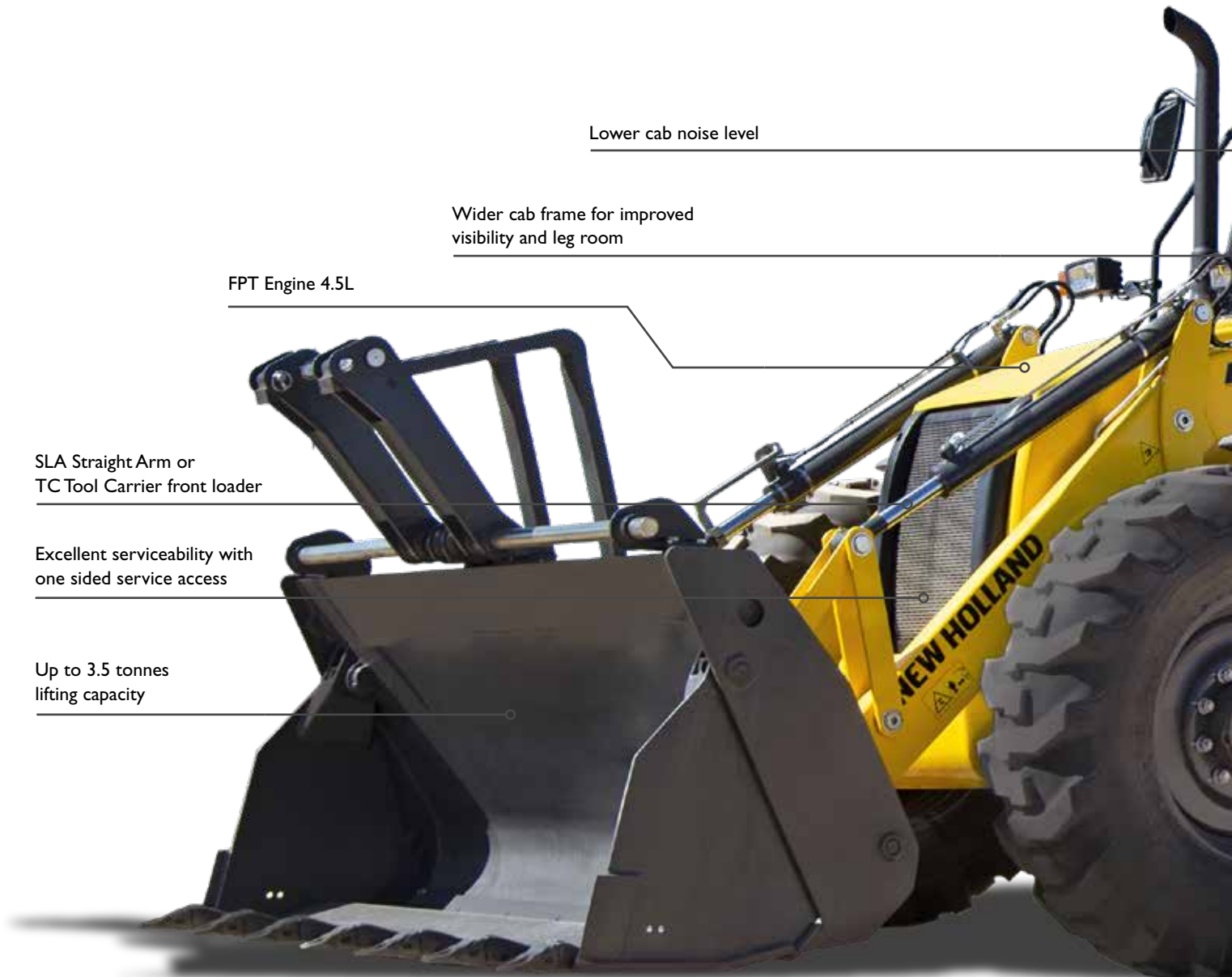



Backhoe craning capacity up to 1410kg

Spacious new cab with 10% increase in volume and added storage compartments

Excellent all-round visibility

Heated seat

Fixed or extendable backhoe dipper

Mechanical or pilot-hydraulic backhoe control

Center pivot or side-shift backhoe

Three steering modes on equal wheel B115 C

New in-cab cool box

Mechanical Powershuttle or Automatic PowerShift™ transmission

New F-N-R switch on the loader multi function lever

WELCOME ABOARD, COMFORT GUARANTEED

The all new class leading C series cab gives you more: more space, more storage, more glass area, more comfort and a host of new features. The cab is now wider, making it easier to turn the seat when switching from front loader work to backhoe use. New rear side windows provide better visibility while the redesigned right side console improves ergonomics and control layout, regardless of what direction you are working in. Storage capacity has been significantly increased with the addition of two lockable compartments, two bottle holders, four open trays and a ventilated cooling box. Operator convenience is improved thanks to the two USB ports for charging mobile devices, Bluetooth radio and mobile phone holder. In-cab noise levels have been reduced by further enhancing operator comfort.

A high grip floor covering comes as standard to help prevent the operator slipping when entering with muddy footwear.

Large retractable sunshades, cup holders, glove box and a deluxe pneumatic heated seat are included and to top it off, the engine exhaust pipe is located to the right side of the cab to provide a clear view of the loader arm.



- Improved clearance and legroom when transitioning to operate the backhoe
- A choice of entry level mechanical and deluxe heated pneumatic suspension seats are available
- Low in-cab noise level
- Good visibility is a key design priority: C Series backhoe loaders benefit from extremely slim cab pillars, front and rear



- Key controls mounted on the side allow operation from both forward and backhoe seat positions
- The dashboard is easy to read with the seat in either its forward or reverse position
- Optional immobiliser system protects against theft and unauthorised use



- Single multifunction proportional control lever for all loader controls
- 4in1 or 6in1 bucket opening, differential lock and transmission de-clutch functions are also activated from the lever
- New F-N-R switch on the multifunction lever for easy direction changes
- Backhoe joystick towers adjust in all directions for the most comfortable position
- New rear side windows in addition to the slim cab pillars allow better visibility when using the backhoe



- Powerful heating and ventilation with standard air conditioning ensures operator comfort throughout the day
- Repositioned ventilation switches are easily accessible regardless of working position
- New ventilated cool box keeps drinks cool
- An abundance of in-cab storage
- New speedometer option on the steering wheel console
- New USB port
- Bluetooth radio and phone holder
- Up-and-over rear window, light and easy to open and close

POWERSHIFT™ OR POWERSHUTTLE, YOU DECIDE

New Holland offers its backhoe loaders with two- or four-wheel drive and a choice of Powershuttle forward / reverse mechanical transmission or automatic PowerShift™. The all-wheel steer B115C has equal size front and rear wheels with selectable front, all-wheel and crab steer modes.



The right front axle for the job

- The heavy duty 4WD front axle has an open differential
- A tight turn radius can be maintained in all conditions



The right rear axle for the job

- The rear axle on all two-wheel steer models is fitted with a fully locking rear differential, engaged via a button on the loader joystick



Mechanical four-speed Powershuttle

- Floor mounted gear lever with steering column mounted electro-hydraulic forward / reverse shuttle
- Four gears with transmission de-clutch button incorporated in the gear lever
- Affordable, dependable and easy to use
- Ideal choice where the backhoe will see more use than the frontloader



Automatic four-speed PowerShift™

- Steering column mounted lever for shuttle and speed selection
- Fully modulated gear shifting with speed matching F-N-R switch on the loader multifunction lever
- Ease of use matched to low maintenance requirements
- Ideal transmission choice for extensive front loader duties
- Loader joystick fitted with transmission de-clutch button to divert full power to hydraulics as required
- Selectable two or four-wheel drive

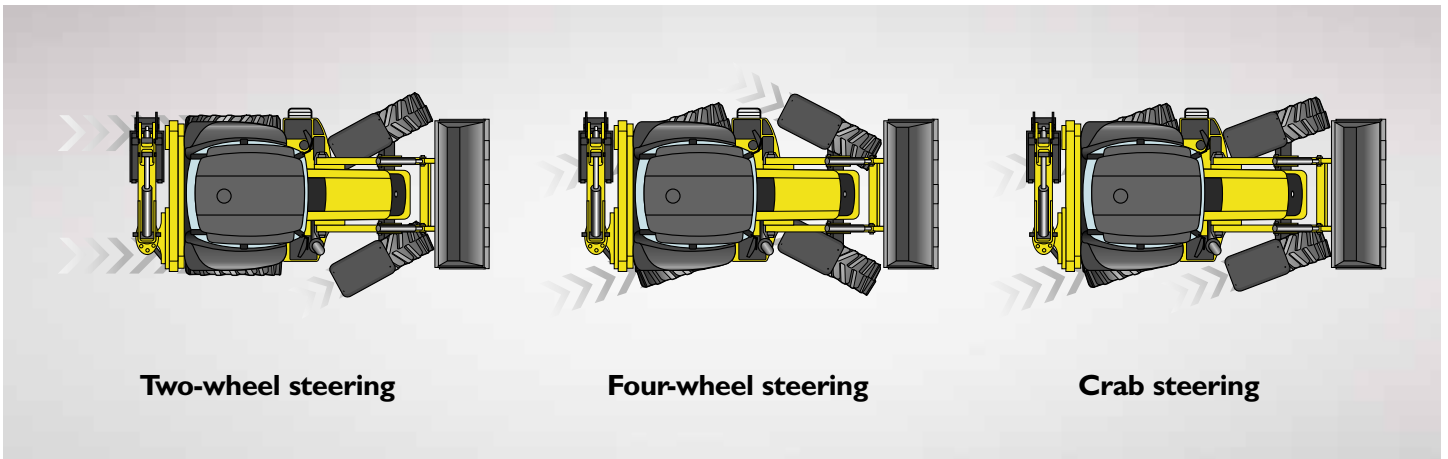

Two-wheel steering

Four-wheel steering

Crab steering

Four-wheel steer BI 15C

New Holland BI 15C model can be operated in one of three steering modes:

- Conventional front-wheel steering is ideal for normal loading and transport applications
- Four-wheel steer delivers excellent manoeuvrability with no impact on stability
- Crab steer is ideal for working close to a trench or obstacle and can be useful when working over sensitive terrain to reduce traffic
- The four-wheel steer BI 15C delivers excellent traction with limited slip differentials in both the front and rear axles. Power is automatically diverted to all wheels in adverse conditions with no need for any operator input
- The self-adjusting oil immersed disc brakes are designed to deliver a dependable performance. Mounted within the reduction hubs, the brakes can be easily serviced with no need to strip the axle

VERSATILITY AT YOUR SERVICE



Front loader - Choose SLA Straight Arm or TC Tool Carrier loader designs

SLA Straight Loader Arm features:

- Hydraulic auto self-levelling
- Higher lift capacity
- Greater lift height

TC Tool Carrier loader arm features:

- Mechanical parallel lift and lower
- Greater reach than straight arm
- Ideal for pallet and loading duties



Common standard loader features

- Auto-glide loader suspension
 - automatically activates above/below 3 preset speeds
 - improves material retention over uneven terrain
 - enables faster load cycle times
 - higher travel speeds for reduced journey times
- Return to dig and float modes
- Choice of standard, 4in I or 6in I buckets
- All buckets have bolt-on teeth for easy renewal



Versatile bucket options

- Versatile 4in I bucket is suitable for such as dozing and grading, bulk materials handling and can work as a grab
- The 6in I design adds adjustable forks for pallet work, lifting open loads and working with a strop



Backhoe

Standard features include:

- Curved arm design for easier loading over trailer sides and obstacles
- Long life pivots with ground level greasing points
- Wide pad stabilisers with adjustable footing
- Powerful bucket and dipper breakout for optimum performance

Key backhoe specification choices include:

- Fixed or extendable dipper arm option
- Mechanical or hydraulic side shift option
- Direct fit or quick coupler bucket choice
- Object handling kit available to allow handling of suspended items



Mechanical controls

- Conventional mechanical controls for the backhoe provide good feedback and response from the hydraulics
- Stabilizer controls are now located right next to the backhoe control levers, improving ergonomics



Pilot controls

- With full proportional control, pilot backhoe control joysticks are fully adjustable
- Selectable ISO or SAE operating patterns
- New joystick rocker switch to control the dipper extension



Hydraulic side shift

- Hydraulic side shift allows precise backhoe positioning and enables the operator to optimise bucket visibility when excavating a trench or working alongside an obstacle
- Hydraulic side shift in combination with the rubber stabilizer pads is the ideal solution to reduce ground damage

HYDRAULICS TO MEET EVERY DEMAND

New Holland backhoe loaders are offered with a choice of hydraulic pump designs to match the precise requirements of end users. In addition, an auxiliary hydraulic circuit is available for powering attachments such as hydraulic breakers and soil augers. Two hydraulic pump designs are offered:

Twin gear pump

- Simple
- Constant flow
- Fast warm up
- Straightforward service and maintenance
- For general use. Suits applications with limited roading

Variable displacement pump

- Only active when there is a demand for oil
- Flow rate proportional to demand
- Reduces fuel consumption
- Reduced oil temperature due to flow on demand
- Ideal for intensive backhoe operation and frequent roading



- A variable displacement hydraulic pump only delivers flow on demand, saving fuel when roading and in applications such as dozing and grading
- The optional auxiliary hydraulic circuit is ideally suited to working soil augers, large grabs and hydraulic breakers

POWERFUL ECONOMY AND EASY MAINTENANCE

FPT Multijet Engine

The FPT engine delivers a big performance in a small package with the lowest maintenance cost in the market:

- The air intake system with centrifugal pre-filter reduces the cleaning intervals
- High turbulence piston and air intake manifold
- High pressure multi-injection common rail for a perfect air-fuel mix and greater burning efficiency
- Mechanical Injection Pump for 580V ensures high power combined with an easy to maintain and serve injection system
- Viscous fan: no power is wasted with its low cooling demands

FPT: a leader in engine technologies.

- Fiat invented the «Common Rail» technology in the 80s
- Fiat Power Train produces over 600.000 industrial engines per year
- Our engines are used not only in earthmoving equipment but also in trucks, agricultural equipment, marine and military applications.



Chassis

All backhoe models benefit from a full frame chassis, its exceptional strength diverting all stress through the robust frame with no load on the engine or transmission.

- Robot welded full length frame chassis
- No stress on engine or transmission
- Plate reinforced stress points
- Cast backhoe slider interface
- Open design to facilitate maintenance



A key to equipment performance and longevity is routine care. New Holland has designed the backhoe loader so it takes the minimum of time to carry out routine checks with easy access to all key fuel, engine, transmission and hydraulic filters, and all engine servicing can be done from one side of the machine for added convenience. Extensive New Holland's widespread dealer network will deliver expert and efficient support for your peace of mind.

- One piece hood for full engine access
- All key daily checks grouped together on one side
- Battery disconnect and remote jump start terminals easily accessible
- All key lubrication points on the loader and backhoe have ground level access
- Key service items accessible from ground level makes the job faster and safer
- Maintenance-free disc brakes are standard



SPECIFICATIONS								
		B90C	B100C	B110C	B115C			
ENGINE								
Make and Model		FPT NEF F4GE9484C	FPT NEF - F4HE0484G	FPT NEF - F4HE9484C	FPT NEF - F4HE9484C			
Injection system		Direct Mechanical	High Pressure Common Rail					
Emissions level		Tier 3						
# of cylinders		4						
Bore / Stroke	mm	104 x 132						
Displacement / Compression ratio	ltr	4.5 / 17.5 to 1						
Engine rated Power (ISO 14396)	Kw(hp)	72 (97) @ 2200 rpm			82 (110) @ 2200 rpm			
Maximum torque (ISO 14396)	Nm	420 @ 1250 rpm	453 Nm @ 1400 rpm	516 @ 1400 rpm				
Engine speeds	rpm	2200 (rated speed at full load) / 950-1000 (low speed at no load)						
TRANSMISSION								
Type		Powershuttle 2WD or 4WD	Powershuttle 4WD	Powershift 4WD	Powershuttle 4WD	Powershift 4WD	Powershift 4WD - 4WS	
Model		Carraro TLBI MPB 2WD or 4WD	Carraro TLBI MPB 4WD	Carraro TLB2 MPB 4WD	Carraro TLBI MPB 4WD	Carraro TLB2 MPB 4WD	Carraro TLB2 MPB 4WS	
Forward travel speeds	kph	6 - 10 - 21 - 40					6 - 10 - 22 - 39	
Reverse travel speeds	kph	7 - 12 - 26 - 47	7 - 12 - 26 - 47* *only for Powershuttle				7 - 12 - 26 - N/A	
FRONT AXLE								
Model		2WD / 4WD Heavy duty	4WD Heavy duty			4WD with limited slip differential		
Oscillation		+/- 11°					+/- 8°	
REAR AXLE								
Model		Carraro 28.44FR with Differential lock		Carraro 28.50FR with Differential lock		Carraro 26.43FR with limited slip differential		
BRAKES								
Service brakes		Hydraulic foot operated, 2 discs per side					Hydraulic foot operated, 3 discs per side	
Parking brakes		Mechanically actuated wet brake pack on transmission output shaft						
TIRES								
Front		16" (2WD) - 18" or 20" (4WD)	18" or 20"			24" or 28"		
Rear		26" or 28" (4WD)	26" or 28" or 30"			24" or 28"		
STEERING								
Type		Hydraulic Power Steering						
System pressure / Displacement	bar/cc	180 / 160						
Turning radius 4WD (external radius)	mm	With 18" tires: 4300 with brakes off 3600 with brakes on	4300 with brakes off 3600 with brakes on			8180 mm in 2WS mode with brakes off; 6820 mm in 2WS mode with brakes on; 4810 mm in 4WS mode with brakes off		
HYDRAULIC SYSTEM								
Type		Load sensing closed center hydraulic system with twin gear pump	Load sensing closed center hydraulic system with twin gear pump	Load sensing closed center hydraulic system with variable displacement pump	Load sensing closed center hydraulic system with twin gear pump	Load sensing closed center hydraulic system with variable displacement pump	Load sensing closed center hydraulic system with twin gear pump	
Flow (@ 2200 rpm)	l/min	156	156	15 to 156	167	15 to 165	167	
Pressure	bar	205						
SERVICE CAPACITIES								
Engine oil	l	13.6						
Transmission oil 2WD/4WD	l	18.5/20.8	20.8					
Front axle 4WD oil	l	9.6					11.8	
Rear axle oil	l	16.3			17.8		12.3	
Hydraulic oil	l	132						
Fuel tank	l	132						
Coolant	l	24						
ELECTRICAL SYSTEM								
Voltage		12V						
Battery		Single: 95 Ah 900 A or Double: 60 Ah, 600 A (each)						
Alternator		120 A						
CAB								
Certification		ROPS / FOPS						
Air Conditioning		Optional						
Storage compartments capacity		45 l including: 2 lockable, cooling box						
Speedometer		Optional						
Bluetooth radio		Optional						
NOISE								
Internal (cab)	dB(A)	77						
External	dB(A)	102			103			

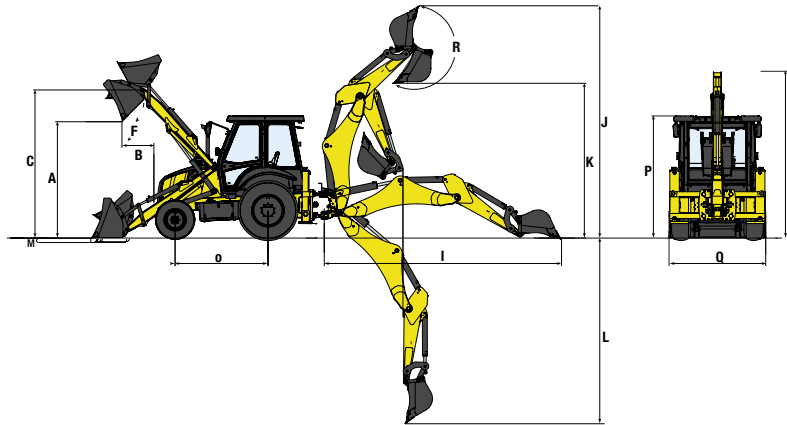

		B90C - B100C - B110C		B90C - B110C		
LOADER (4WD configuration)		TOOL CARRIER LOADER ARM		STRAIGHT LOADER ARM		
		Std bucket	4x1 bucket	Std bucket	4x1 bucket	
A	Maximum dump height under bucket at 45°	mm	2606	2665	2711	2733
B	Dump Reach at full height	mm	844	771	815	757
C	Maximum height pin	mm	3461		3498	
F	Dump angle	°	43		40	
M	Below ground level digging depth	mm	166	139	105	158
	Maximum lifting capacity @ ground level	kg	5670		4970	4745
	Maximum lifting capacity @ max height	kg	3678		3553	3290
	Loader breakout force	daN	3015		3625	
	Bucket breakout force	daN	4062	4076	6340	6220

		B90C - B100C - B110C				
BACKHOE		IN-LINE CYLINDER				
		STD DIPPER	EXTENDABLE DIPPER	STD DIPPER	EXTENDABLE DIPPER	
	Backhoe size	ft	14		15	
	Swinging angle	°	180			
I	Maximum reach from swing center	mm	5579	6313	5831	6965
J	Maximum operating height	mm	5425	6173	5616	6348
K	Maximum loading height	mm	3658	4424	3867	4601
L	Maximum digging depth	mm	4385	5627	4666	5881
R	Bucket rotation	°	203			
	Bucket breakout force	daN	4745			
	Dipper breakout force	daN	3767	2592	3358	2389

		B90C - B100C - B110C				
OVERALL DIMENSIONS						
G	Boom height (transport position)	mm	3800	3882	3800	3882
O	Wheel base	mm	2183			
P	Cab height	mm	2859			
Q	Overall width with standard loader bucket	mm	2340		2394	
	Minimum ground clearance	mm	337			

		B90C - B100C		B110C	
Operating weight range	Kg	8010 - 9220		8080 - 9220	

Operating weight is subject to machine configuration and attachment options

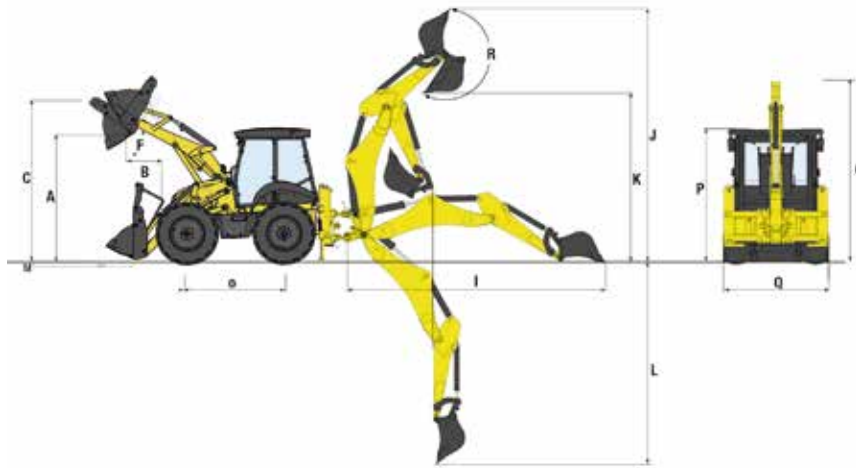

		B115C		
LOADER (4WD configuration)		TOOL CARRIER LOADER ARM		
		Std bucket	4x1 bucket	
A	Maximum dump height under bucket at 45°	mm	2708	2619
B	Dump Reach at full height	mm	799	587
C	Maximum height pin	mm	3478	
F	Dump angle	°	56	
M	Below ground level digging depth	mm	93	127
	Maximum lifting capacity @ ground level	kg	4770	4580
	Maximum lifting capacity @ max height	kg	3380	3075
	Loader breakout force	daN	3554	3536
	Bucket breakout force	daN	5411	5497

		B115C		
BACKHOE		IN-LINE CYLINDER		
		STD DIPPER	EXTENDABLE DIPPER	
	Backhoe size	ft	15	
	Swinging angle	°	180	
I	Maximum reach from swing center	mm	5831	6965
J	Maximum operating height	mm	5616	6348
K	Maximum loading height	mm	3867	4601
L	Maximum digging depth	mm	4666	5881
R	Bucket rotation	°	203	
	Bucket breakout force	daN	5971	
	Dipper breakout force	daN	3225	2389

		B115C		
OVERALL DIMENSIONS				
G	Boom height (transport position)	mm	3922	4013
O	Wheel base	mm	2200	
P	Cab height	mm	2964	
Q	Overall width with standard loader bucket	mm	2452	
	Minimum ground clearance	mm	450	

		B115C	
Operating weight range	Kg	8800 - 9310	

Operating weight is subject to machine configuration and attachment options



The New Holland dealer network is, in itself, the best guarantee of continued productivity for the machines it delivers to its customers. New Holland service technicians are fully equipped to resolve all maintenance and repair issues, with each and every service point providing the high standards of New Holland's stringent quality guidelines.

The New Holland global parts network ensures fast, reliable, replacement parts for less downtime, increased productivity and, of course, profitable operation for its customers.

Learn more at www.newholland.com

Printed on recycled paper
CoC-FSC 000010 CQ Mixed sources



AT YOUR OWN DEALERSHIP

The information contained in this brochure is intended to be of general nature only. The NEW HOLLAND CONSTRUCTION MACHINERY S.p.A. company may at any time and from time to time, for technical or other necessary reasons, modify any of the details or specifications of the product described in this brochure. Illustrations do not necessarily show products in standard conditions. The dimensions, weights and capacities shown herein, as well as any conversion data used, are approximate only and are subject to variations within normal manufacturing techniques.