

## 4 - OPERATING INSTRUCTIONS

### Starting the unit

### Security function

In order to prevent the theft of the machine, the security function is available. Whether enabling this function or not is selected when the ignition key is turned OFF (lock guidance screen). To operate the machine with this function enabled, a password needs to be input.

For setup of the security function, consult the CASE CONSTRUCTION dealer. Entering wrong passwords for 3 times or more, or starting up the engine before entering password causes generation of warning and activation of the machine is subject to restriction.

This is called immobilized status.

1. Travel alarm sounds.
2. Monitor buzzer sounds continuously.
3. The swing function is disabled.
4. Although the engine starts, its speed is fixed at a low idle.
5. When the operation lever is used in the state of 4, the engine will stop automatically.

**NOTE:** Be careful not to forget the recorded code. The code cannot be changed without prior consultation the CASE dealer.

### Enabling the security function

When the operator turns the starter key OFF, the lock guidance screen is displayed on the monitor screen.

To change the security function setting, press the lock switch (3) while the lock guidance screen is displayed.

The machine can be locked by enabling the security function.

- (1) Security function disabled
- (2) Security function enabled

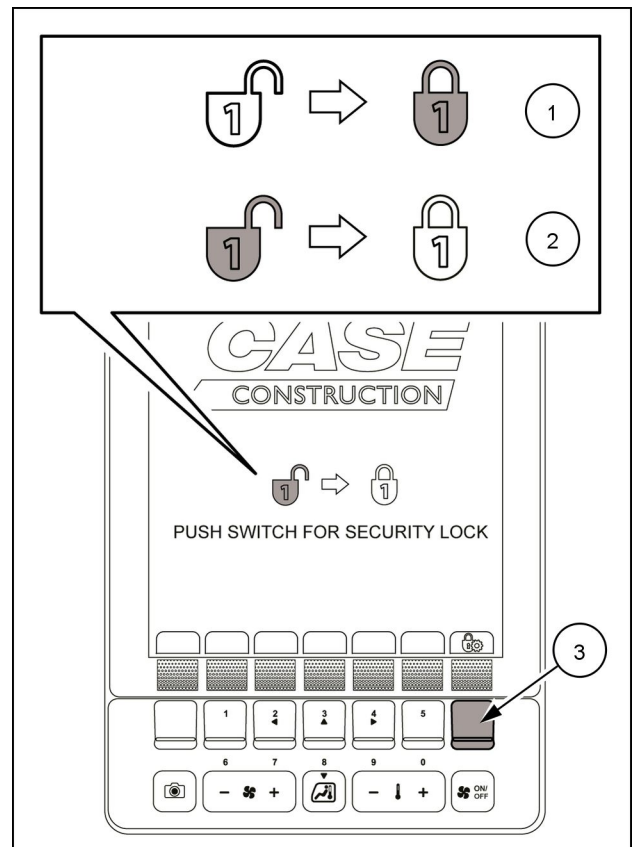

SMIL22CEX1271BA 1

## Disabling the security function

If the security function is enabled, when the operator turns the starter key ON, the password entry screen is displayed.

Use the monitor switches to enter the password on the entry screen to unlock.

If the machine cannot be unlocked:

1. The machine becomes immobilized, but you can continue to enter the password.
2. If password verification failed 3 times in total, you cannot enter the password anymore. Turn the starter key OFF and then turn the starter key ON again, then enter the password again.
3. If you start the engine before entering the password, the machine becomes immobilized.

**NOTICE:** If you forgot your password, consult your CASE CONSTRUCTION dealer.

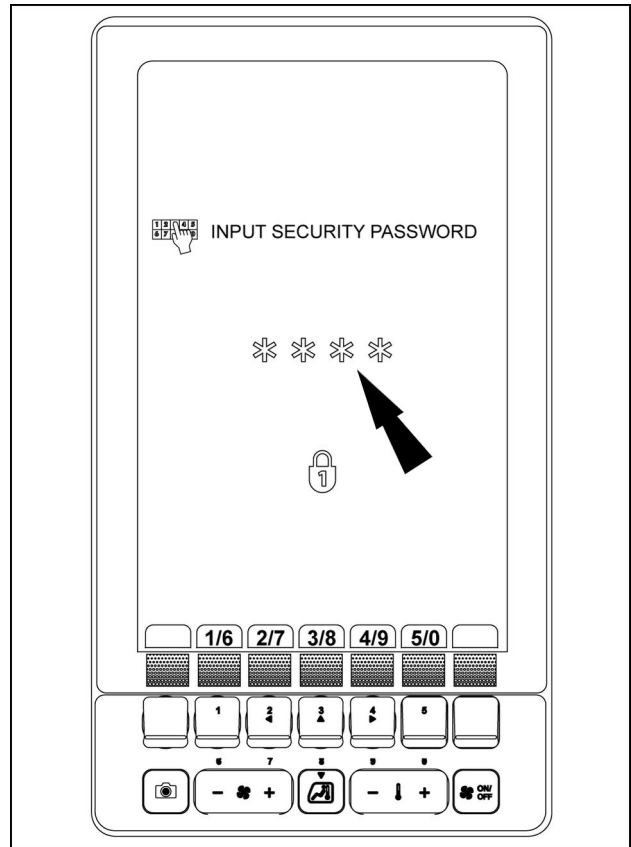

SMIL21CEX3152BA 2

## Starting the engine

### ⚠ WARNING

**Hazard to bystanders!**  
**Make sure the area surrounding the machine is clear of all persons before starting the engine.**  
**Failure to comply could result in death or serious injury.**

W0090A

### ⚠ WARNING

**Avoid injury!**  
**Before starting the engine, securely fasten the seat belt. The seat belt can help ensure your safety if it is properly used and maintained. Never wear a seat belt loosely or with slack in the belt system. Never wear the belt if it is twisted or pinched between the seat structures.**  
**Failure to comply could result in death or serious injury.**

W0142A

### ⚠ WARNING

**Toxic gas and asphyxiation hazard!**  
**Diesel exhaust contains dangerous compounds. Never operate the engine in a closed building or area. Proper ventilation is required under all circumstances.**  
**Failure to comply could result in death or serious injury.**

W1302A

1. Check that there is no abnormality in the machine.
2. Confirm that the engine hood and the side doors are closed and locked.
3. Confirm that the gate lock lever (1) is in central position (B) (the safety bar (2) is in inward position).
4. Set each operation lever in neutral.
5. Securely fasten the seat belt.

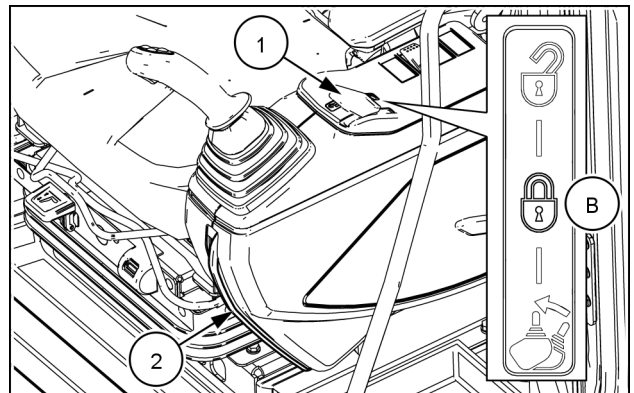

SMIL22CEX1957AA 1

6. Confirm that the engine speed throttle (3) is in low idle position.
7. Turn the starter key (4) to ON position. The buzzer of the instrument cluster, the travel alarm (if equipped), and the warning buzzer of the Quick Coupling System (if equipped) will make a check sound.

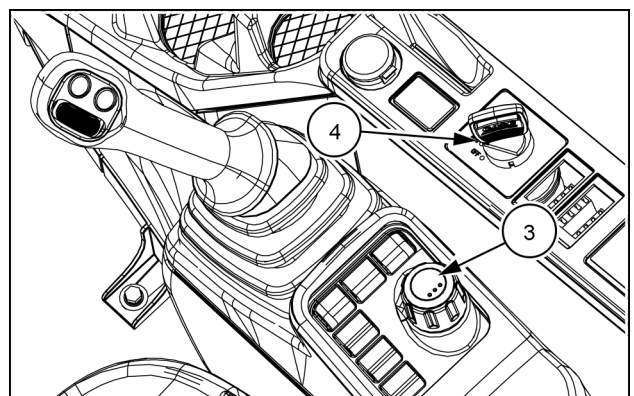

SMIL21CEX3158AA 2

8. Unlock the display if the security function had been activated. When operating the machine in severe winter climates, the engine preheating icon is displayed as the engine is being preheated automatically.



The engine is preheating.

Wait for the auto preheat to complete and the icon to disappear.

9. Sound the horn with the button on the left control lever to warn that the machine is starting up.
10. Turn the starter key (4) to START position. The engine running takes approximately 1 s to stabilize after it has been cranked up. Release the starter key as soon as the engine is running regularly.

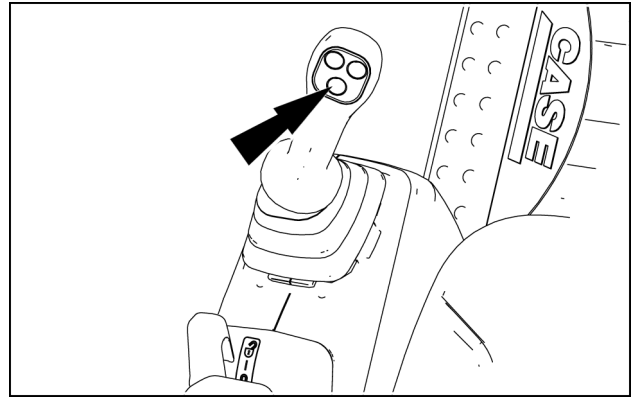

SML21CEX3112AA 3

**NOTICE:** The cranking up of the engine may be difficult in severe winter climate. If the engine does not start after 10 s of operation of the starter motor, turn the key to OFF position and wait 2 min before attempting a new cranking.

**NOTICE:** When the engine is started in severe winter climate, moisture vapor may be temporarily generated resulting in a whitened smoke.

**NOTICE:** Immediately after the engine is started, the engine sound is louder compared to the sound after the engine is warmed up, and also the color of the exhaust smoke becomes more whitened or more blackened than the smoke emitted during the normal operation. The engine sound and the color of the exhaust smoke get smoothed after the engine is warmed up.

**NOTICE:** Due to resonance, vibration might come up while the engine is running at low speed. Increasing slightly the engine speed reduces the vibration.

This icon lights up when the seat belt is not worn and goes out when the seat belt is worn.



Displayed when the seat belt is not worn.

## Bringing the machine up to operating temperature

Before starting operation, the main systems of the machine should be warmed up to their normal operating temperature.

**NOTE:** The normal operating temperature for the hydraulic fluid is **50 – 80 °C (122 – 176 °F)** . This corresponds to four segments lit on the hydraulic temperature gauge.

**NOTE:** The normal operating temperature for the engine coolant is **75 – 90 °C (167 – 194 °F)**. This corresponds to four segments lit on the coolant temperature gauge.

A warm-up procedure should be carried out in order to grant a proper and safe usage of the machine, and in order to grant the best machine performance and fuel efficiency.

**NOTICE:** The warm-up of the machine is mandatory when operating in severe winter climates.

**NOTICE:** The warm-up of the machine prevents wear and severe damages to the engine, to the fuel system, to the SCR system and to the hydraulic system.

**NOTICE:** The exhaust pipe becomes extremely hot while the engine is idling. Make sure that there is no flammable material such as plants, dried grass, paper waste, oil and old tires close to the exhaust pipe before starting warm-up procedure.

**NOTICE:** Never cover the grids of the radiators with flammable materials.

### Automatic machine warm up

Regardless of the ambient conditions, the machine control system allows to carry out an automatic warm-up procedure that brings the temperature of the main operating fluids to the proper level for machine operation.

Start the engine with the speed throttle in the low idle position and let the machine complete the automatic warm-up procedure. During the automatic warm-up, the engine speed and the engine load are automatically managed in order to match the warm-up cycle to the ambient conditions and to optimize the warm-up cycle in respect to the machine operating parameters.

**NOTE:** the engine speed and the noise of the hydraulics are supposed to change during the warm-up cycle.

**NOTICE:** The automatic warm-up procedure is the recommended operating practice. However, the automatic warm-up procedure can be overridden either by changing the engine speed manually or by operating any operation lever.

As the procedure starts up, the message AUTO WARM UP is displayed:



The automatic warm-up procedure takes about **5 – 10 min** depending on the ambient conditions.

After completion of the automatic warm-up procedure, the AUTO WARM UP message disappears, and the engine speed gets back to low idle.

## Manual machine warm up

A manual machine warm-up can be carried out referring to the following procedure:

1. Set the engine speed throttle three steps over the low idle position.
2. Start the engine and let it run approximately for **5 – 10 min** with no load.
3. When the coolant temperature reaches the second segment on the coolant temperature gauge, set the engine speed throttle in intermediate position.
4. Push the gate lock lever forward (the safety bar is facing outward).
5. Move the bucket control slowly until the bucket is fully curled.
6. Operate the arm until the it is completely retracted, and hold the position for **30 s**.
7. Extend the arm completely, and hold the position for **30 s**.
8. Repeat the sequence of extending and retracting the arm until the temperature of the hydraulic fluid raises over the first two segments on the hydraulic temperature gauge, corresponding to **25 °C (77 °F)**.

**NOTICE:** Never overload the hydraulic system until the temperature of the hydraulic fluid reaches **25 °C (77 °F)**. If the hydraulic system is overloaded with the temperature of the hydraulic fluid below **25 °C (77 °F)** it will be severely damaged.

9. Gently operate the controls for travel, front equipment and swing for 3 to 4 times to circulate warmed hydraulic fluid into the whole circuit.

Check the followings after reaching normal operating temperature of the fluids:

- Exhaust gas is normal.
- No unusual noise or vibration.
- No leak of oil, fuel or water.
- No unusual noise when activating the hydraulic equipment.
- Inspection of the horn, buzzer, working lights and instrument cluster.
- Proper display of the temperature gauges.
- Check the visibility from the rear view mirrors, the side view mirrors and the cameras before operation. Adjust and clean up dirt as necessary.
- Check each operation (travel, front equipment and swing).

If any of the following occurs during the warm-up procedure, stop the engine immediately.

- Engine speed increases or decreases rapidly.
- Engine sound and exhaust gas color are abnormal.
- Messages are displayed, and a warning alarm sounds.

## Operating the machine in hot or cold weather

### In cold weather

- Make sure to use fluids and lubricants which have specifications suitable for operation at low ambient temperatures.
- Check the batteries for full charge state.
- Fill up the fuel tank after completing the work, and then drain water before starting work on the next day in order to prevent dew condensation and invasion of water to the fuel system.
- Use fuel which is rated to the outside air temperature, or proper anti-freeze in order to prevent crystal generation at **-2 °C (28 °F)**.

**NOTICE:** Before transporting the machine to a cold region, fill the tank with fuel that has a low freezing temperature.

### In hot weather

- Make sure to use fluids and lubricants which have specifications suitable for operation at high ambient temperatures.
- Keep the coolant at the correct level in the coolant reservoir and in the radiator.
- Use the correct solution of ethylene glycol and water in the cooling system.
- Test the radiator cap before hot weather starts. Replace the cap as required.
- Clean all dirt and debris from the radiator, cooler and engine area.
- Check the condition of the fan drive belt.

### Operation under dusty and sandy conditions

- Frequently inspect the element of the air cleaner and clean or replace the element and the dust cup regardless of service due.
- Tightly close the breather cap of the hydraulic tank to prevent invasion of sand and dust to the hydraulic circuits.
- Make sure to thoroughly clean the grease fittings before greasing any lubrication point of each pin and bush.
- Make sure to clean the radiator fin and oil cooler fin and the radiator grid.

### Operation on seashore

- Inspect tightness of the plugs/cocks/bolts in each point in order to prevent salt corrosion.
- Thoroughly wash the machine after the work, especially take good care of the electrical equipment and hydraulic cylinder to prevent corrosion.

### Operation on highly humid land or soft land

- Keep the machine as dry as possible during operation and make sure to carry out regular lubrication. Moisture and mud water cause deterioration and corrosion of paints/wirings/metal components.

## Operating the machine

### **⚠ WARNING**

#### **Hazard to bystanders!**

**Always know the location of all workers in your area. Warn them before you start working on the machine. Always keep all unauthorized bystanders clear of the area. Failure to comply could result in death or serious injury.**

W0176A

### **⚠ WARNING**

#### **Misuse hazard!**

**Follow the operating instructions in this chapter. Any other practice that has not received the prior approval of the manufacturer is considered to be strictly forbidden. Failure to comply could result in death or serious injury.**

W0281A

- Pay attention to work condition characteristics of ground and climate condition before operating the machine.
- Inspect every possible risk before operating the machine. Holes on working site, obstructions and hazardous materials such as debris are subject to cause serious accident.
- Pay attention to location of pipes and cables before commencing work. Electric cables, gas pipes, water pipes and underground installations may cause serious injury. If the work takes place adjacent to high voltage power lines make sure to check the following work range:  
Less than **57000 V**: **4 m (13.1 ft)**  
**57000 V** or more: **5 m (16.4 ft)**
- Sit on the operator's seat, adjust it so as to be able to easily reach the console, and then fasten the safety belt.
- Check that the cab door is tightly secured at position of open or close.
- Sound the horn.
- Start up the engine.
- Check all the indicator lamps and gauges are operating properly.
- Push the gate lock lever forward (the safety bar is facing outward).

The following operation may cause damage to the machine:

- Do not use weight of the machine as an impact force for excavation.
- Do not use traveling force of the machine for excavation.
- Avoid abrupt change of swing direction when swinging the upper structure.
- Never hit or push objects with side of the bucket. Do not sweep ground with the bucket to level rubbles.
- Open and close the bucket for several times to loosen soil and mud when soil and mud are tightly packed in the bucket.
- After work, remove mud from the machine and clean it.



## Operating the machine on soft ground or in water

- The machine could gradually sink when working on soft ground. Pay attention to undercarriage during work.
- Before operating the machine in water, check the water depth and the footing. Permissible water depth is up to the upper rollers.
- After operation underwater or on soft ground, apply grease to the attachment and the turntable bearings. Clean and inspect the undercarriage as well.
- In case of accidental sinking in water or soil up to the swing body, replacement of grease and service are required. Terminate operation, and contact the CASE CONSTRUCTION dealer.

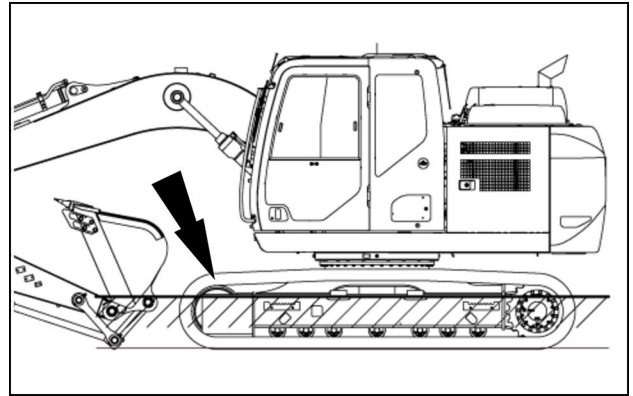

SMIL21CEX5559AA 1

**NOTICE:** Do not operate in a fast flowing stream.

## Operating the machine on sloping ground

### ⚠ WARNING

#### Overturning hazard!

Before parking the machine, make sure the ground is stable. Plan the worksite so that the ground is flat, hard, and level.

Failure to comply could result in death or serious injury.

W0258A

### ⚠ WARNING

#### Driving hazard!

Hillside operations can be dangerous. Rain, snow, ice, loose gravel, or soft ground, etc. can change the ground conditions. You must make a judgment if it is safe to operate your machine on any hillside or ramp.

Failure to comply could result in death or serious injury.

W0144A

The machine gradeability is **35° ( 70%)**.

**NOTICE:** Do not operate the engine when incline of the machine is **35° or more**. The engine or the hydraulic system may be damaged.

During hillside operations, be extra careful.

- Maintain the maximum engine speed.
- Make sure that the low speed travel is selected.
- Always keep the travel reduction gears pointing down towards the bottom of the slope.
- Always travel in the same direction as the slope, to prevent the machine from turning over. Never decelerate when descending a slope.
- Raise the bucket about **40 cm (15.75 in)** away from ground when ascending a slope. Contact the bucket on ground to avoid slipping the machine when descending a slope.
- Avoid swinging to a direction of travel on a **15°** slope, or avoid swinging perpendicular to direction of travel on a **10°** slope.
- During digging operation, avoid swinging the upperstructure towards the bottom of the slope with the bucket full.

## Digging and loading operations

Use the P work mode for general digging and truck loading operations.

You can set E work mode to optimizes fuel efficiency

Use the SP work mode for heavy digging operation.

### Filling

Fill the bucket by maneuvering the arm.

Keep the bottom of the bucket parallel to the cut.

The bucket teeth and blade must cut the ground like the blade of a knife.

The depth of dig varies depending on the type of material.

### Excavating method

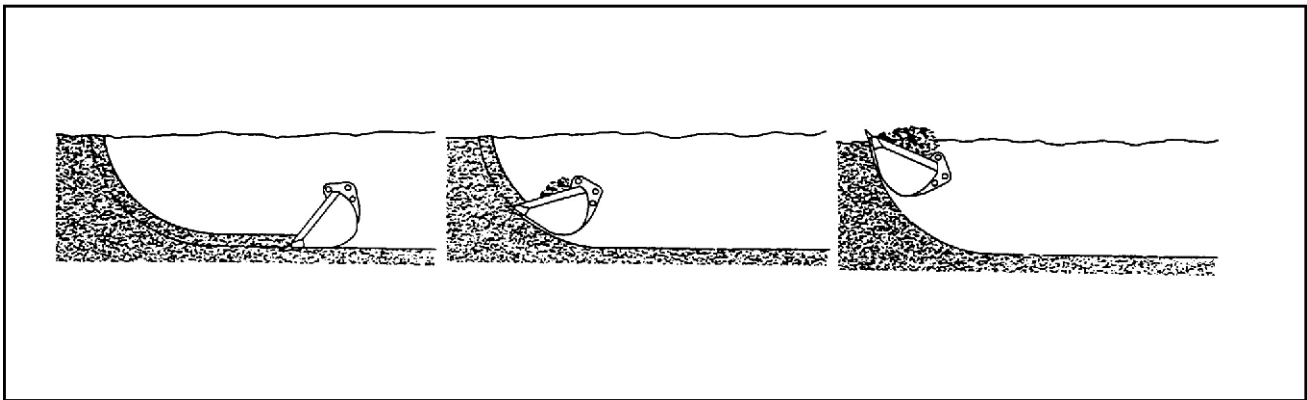

SMIL13CEX2693EA 2

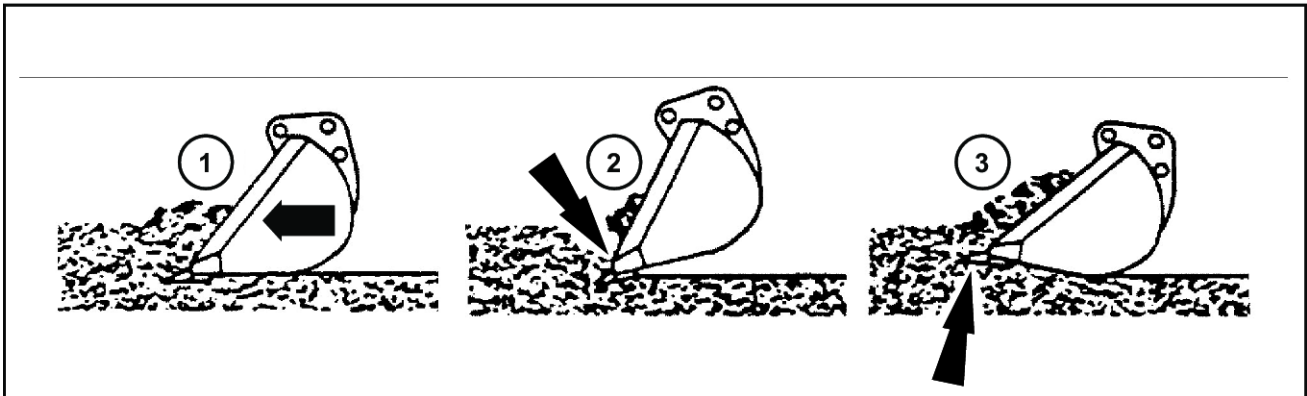

SMIL13CEX2694EB 3

1. Correct
2. Incorrect. The bucket will dig in and cause a stall.
3. Incorrect. The bucket is pushed upwards. This will also increase the cycle time.

## Lowering the attachment in the event of a failure

### ⚠ WARNING

#### Unexpected machine movement!

Only use the following procedure in case of machine failure. Always use extreme caution during operations. Keep other persons away from the bucket, attachment, and boom. The bucket or attachment can move unexpectedly during operations due to weight of the bucket, attachment, arm, or boom.

Failure to comply could result in death or serious injury.

W1364A

### ⚠ CAUTION

#### Crushing hazard!

Keep away from the space under the bucket or attachment when lowering the bucket or attachment. In cases where the machine fails and the engine stops, lower the attachment using the procedure described in this manual.

Failure to comply could result in minor or moderate injury.

C0169A

**NOTICE:** the procedure should be completed within five minutes after the engine stops. The accumulator pressure will gradually falls which will disable the ability to lower the attachment.

If the engine breaks down, use the following procedure to lower the attachment:

1. Turn the starter key to ON position.

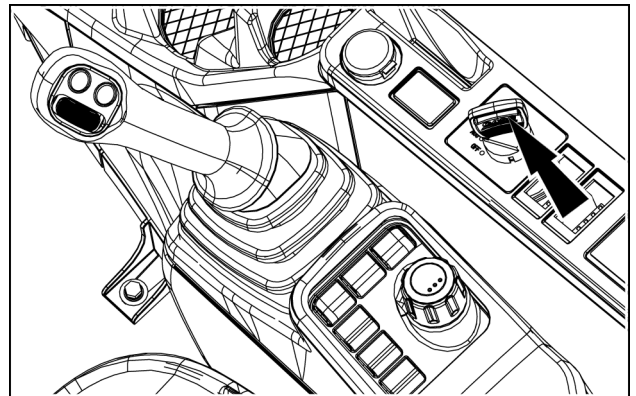

SMIL21CEX3158AA 1

2. Set the gate lock lever (1) to the normal operating position (A) with safety bar (2) raised.

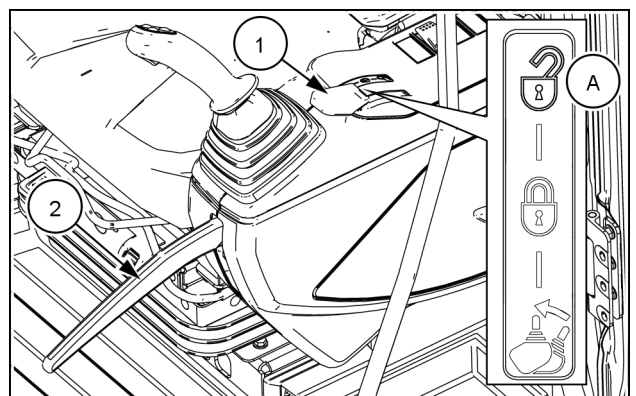

SMIL22CEX1958AA 2

3. Slowly operate the control levers to lower the attachment to the ground.

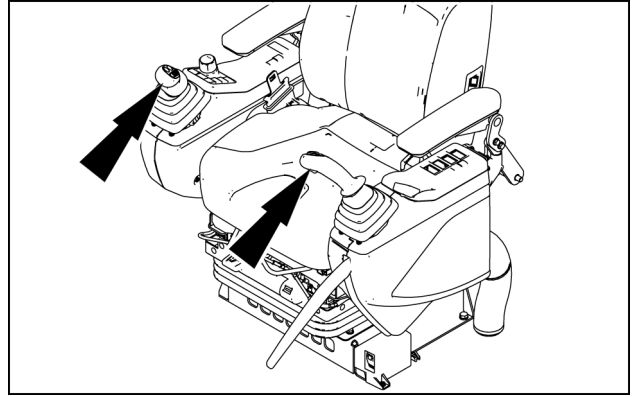

SML21CEX3157AA 3

## Bucket replacement

### ⚠ CAUTION

#### Avoid injury!

Handle all parts carefully. Do not place your hands or fingers between parts. Use Personal Protective Equipment (PPE) as indicated in this manual, including protective goggles, gloves, and safety footwear.

Failure to comply could result in minor or moderate injury.

C0145A

To remove the bucket from the linkage, proceed as follows:

1. Operate the arm and bucket controls so that the arm stands vertical and the bottom side of the bucket leans against a hard and level ground.

**NOTICE:** never push the bucket onto the ground. The bucket pins should be unloaded in order to be properly extracted from the bushings.

2. Place the gate lock lever in central position, stop the engine and remove the starter key.
3. Slide the O-ring seals onto the inner bosses of the bucket.
4. Unlock the bucket pins by removing either the retaining pins or the locking bolts. Check the locking tools for wear or damage. Make sure to properly store the locking tools to prevent damage.
5. Place a punch on the flat edge of the pin (1), and push it out using a hammer. Extract the pin (2) using the same procedure. Make sure to properly handle and store the bucket pins to prevent damage.

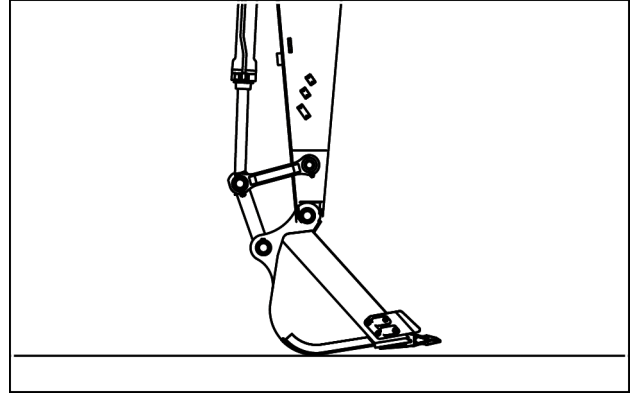

SMIL16CEX0478AA 1

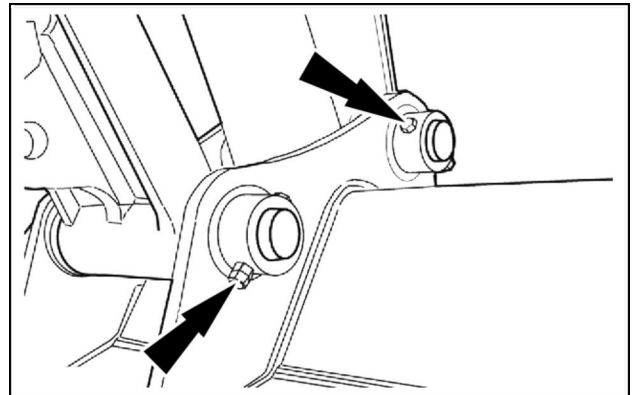

SMIL13CEX2827AB 2

6. Get onto the cab, start the engine and place the gate lock lever in the forward position.
7. Gently retract the bucket cylinder to release the bucket connecting rod from the bucket hangers.
8. Gently operate the arm and boom controls to release the arm top from the bucket hangers. Check the O-ring seals and the mounting spacers for wear or damage. Make sure to properly store the O-ring seals and the mounting spacers to prevent damage.

**NOTICE:** If the bucket linkage does not easily come out from the bucket hangers, lower the bucket to the ground. In order to unstick the mating surfaces, gently operate the bucket control to extend the bucket cylinder or the boom control to push down the arm top.

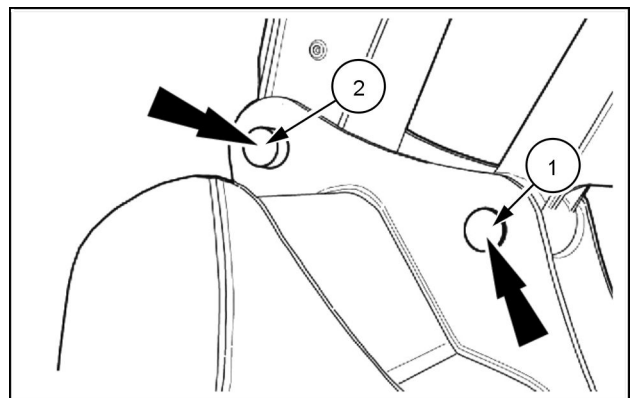

SMIL13CEX2828AB 3

To mount the bucket to the linkage, proceed as follows:

1. Make sure that the machine and the bucket stand both onto a hard and level ground. The bucket should stand on its bottom side.
2. Place the O-ring seals onto the inner bosses of the bucket.
3. Position the machine close to the bucket, and gently operate the boom and arm controls in order to align the arm top between the respective bosses on the bucket.
4. Place the gate lock lever in central position, stop the engine and remove the starter key.
5. Position the mounting spacers if required. Place a punch on the flat edge of the pin **(2)**, and push it in using a hammer.

**NOTICE:** Make sure to insert the pin by its chamfered edge. Make sure to insert the pin from the bucket side opposite to the locking boss.

6. Push the pin until the locking hole on the pin is aligned to the locking hole on the bucket boss. Install either the retaining pin or the locking bolt.
7. Get into the cab, start the engine and place the gate lock lever in the forward position.
8. Gently extend the bucket cylinder to align the bucket connecting rod between the respective bosses on the bucket.
9. Place the gate lock lever in central position, stop the engine and remove the starter key.
10. Insert the pin **(1)** and lock it as described for the pin **(2)**.
11. Slide down the O-ring seals. Grease the bucket pins.

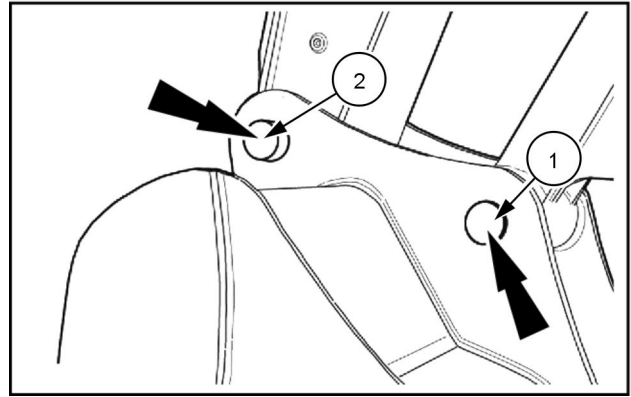

SMIL13CEX2828AB 4

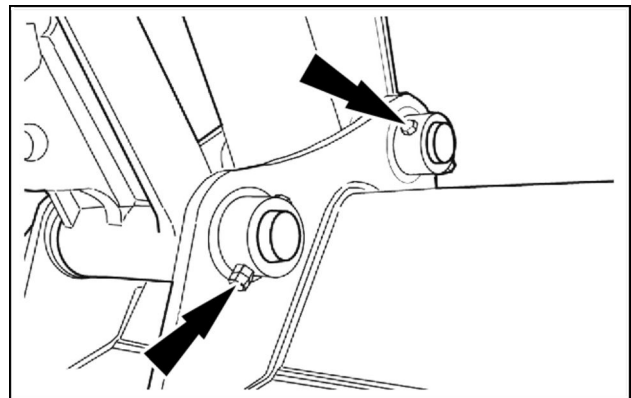

SMIL13CEX2827AB 5

## Stopping the unit

### Stopping the engine

1. Lower the attachment until it is resting on the ground.
2. Turn the engine throttle (1) to low idle position.
3. Wait for the green cooling down icon to appear.



The engine has cooled down and can be stopped.

4. Turn the starter key (2) to OFF position.

If the key is turned to OFF position before the green icon appears, the engine stops, but the warning message **IMPROPER SHUT DOWN** appears on the top of the display, and the audible alarm sounds.



Do not repeat anymore this early shut down in order to avoid severe damages to the engine and its components.

**NOTICE:** *If the engine is stopped before the green icon appears, the lubricated section on the turbocharger gets dried from the high heat, leading to a turbocharger failure.*

The ATS system continues to operate for approximately **3 min** after the starter key is turned off in order to suck **DEF/AdBLUE®** back into the tank. **DEF/AdBLUE®** expands when freezing, and it will thus damage the lines of the ATS system. This is considered normal, and requires no action from the operator.

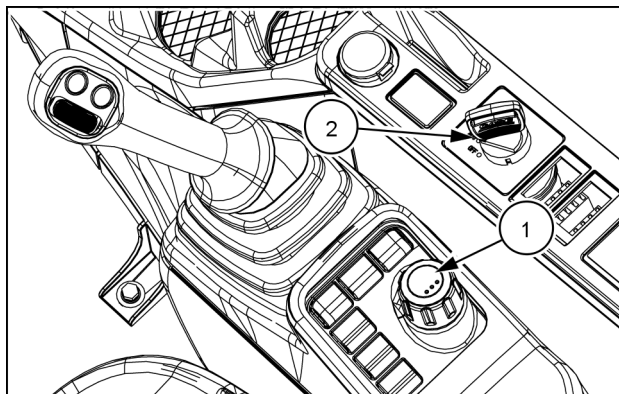

SMIL21CEX3158AA 1

## Emergency stop switch

The emergency stop switch is located under the left-hand console.

The emergency stop switch enables the engine to be shut down in emergency or when it is not possible to shut it down by means of the starter key.

**NOTICE:** *The emergency stop switch should be used for emergency purpose only. Do not use it on a day-to-day basis to stop the engine.*

Press on the front of the switch to stop the engine. The audible warning device sounds and the message ENGINE STOP is displayed.

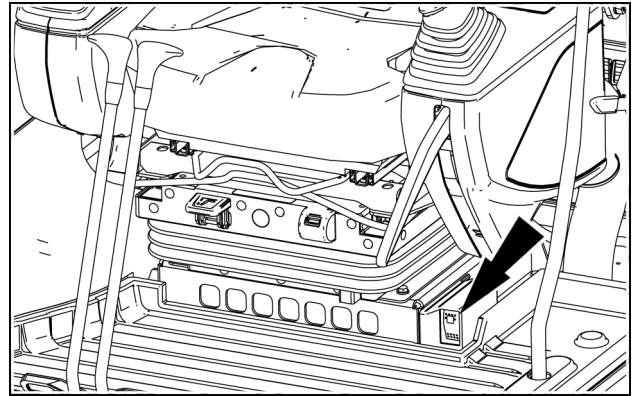

SMIL22CEX1955AA 2



To start the engine again, press on the back of the emergency stop switch, turn the starter key to OFF position, and then restart the engine.



## Moving the unit

### Machine travel

#### ⚠ WARNING

Controls can be reversed!

In the normal travel position, the operator's compartment is above the idler wheels and the travel reduction gears are to the rear of the upper structure. If the upper structure is turned 180 degrees in relation to the undercarriage, the controls are reversed.

Failure to comply could result in death or serious injury.

W0289A

#### ⚠ WARNING

Hazard to bystanders!

Always sound the horn before starting the machine. Make sure the work area is clear of other persons, domestic animals, tools, etc. before you operate the machine. Never allow anyone in the work area during machine operation.

Failure to comply could result in death or serious injury.

W0304A

**NOTE:** increase the engine speed before start traveling. Fold the attachment to raise it to **40 – 50 cm (15.7 – 19.7 in)** above ground.

### Selection of travel speed

#### ⚠ WARNING

Loss of control hazard!

Avoid pressing the travel speed button while traveling. Avoid shifting to FAST speed when traveling downhill or when loading/unloading from a trailer.

Failure to comply could result in death or serious injury.

W0390A

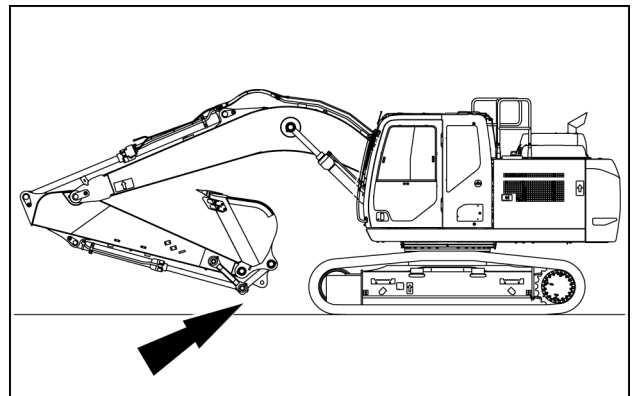

SMIL22CEX4190FA 1

Before start traveling, make sure to select the proper travel mode between "Turtle" and "Rabbit".

As the travel mode is selected, the travel speed varies with the tilting angle of the travel control levers and pedals. Refer to Chapter 8 for speed ranges.

### Travel alarm

The travel alarm sounds when the travel controls are activated.

The TRAVEL ALARM TIME function on the monitor allows to set how long the travel alarm sounds during travel operation ( **10 s, 20 s, 30 s, 60 s, ∞ s**).

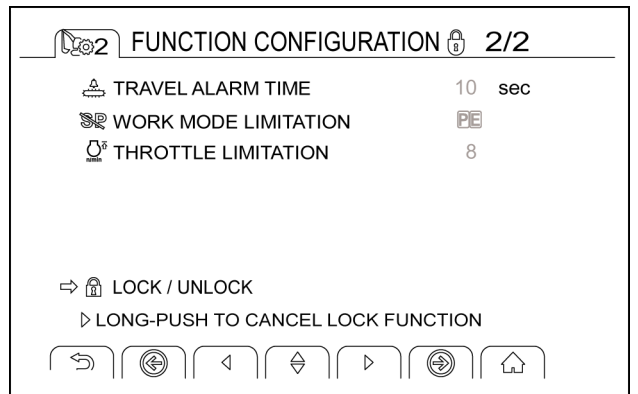

SMIL21CEX3134AA 2

**Straight line travel (forward travel)**

Press the two pedals (or push the two levers) forward at the same time.

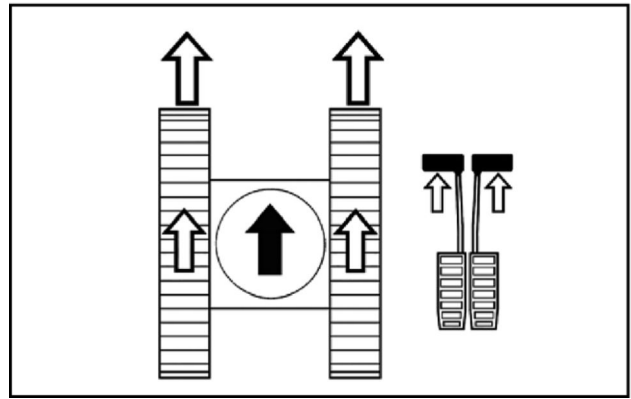

SMIL13CEX2679AB 3

**Straight line travel (reverse travel)**

Press the two pedals (or pull the two levers) rearwards at the same time.

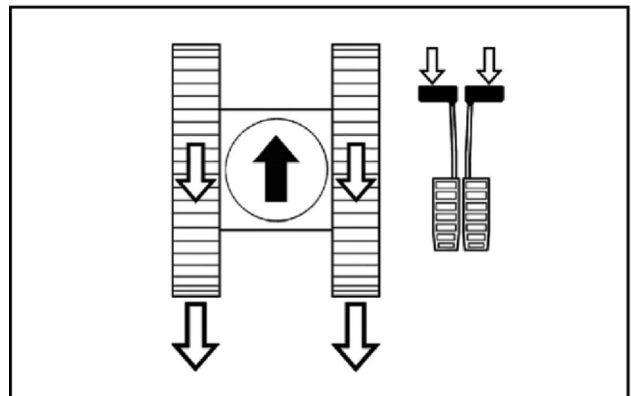

SMIL13CEX2680AB 4

**Turning to the left (forward travel)**

Simply press the right-hand pedal or push the right-hand lever forwards.

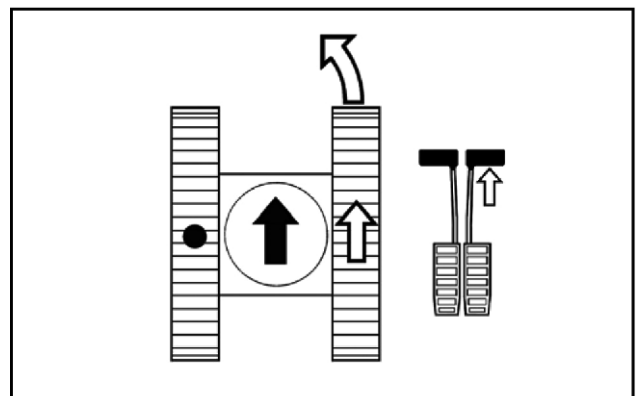

SMIL13CEX2681AB 5

**Turning to the right (forward travel)**

Simply press the left-hand pedal or push the left-hand lever forwards.

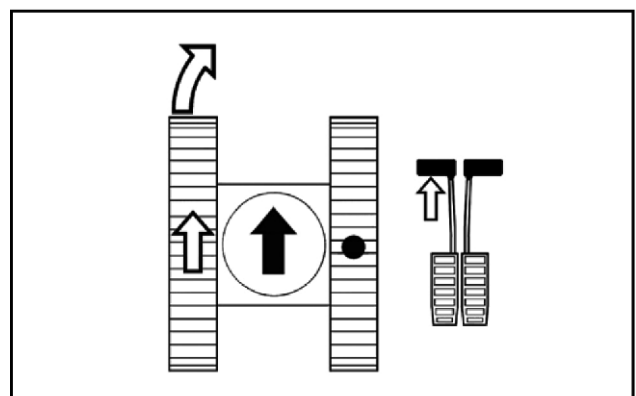

SMIL13CEX2682AB 6

### Turning to the left (reverse travel)

Simply press the right-hand pedal or pull the right-hand lever rearwards.

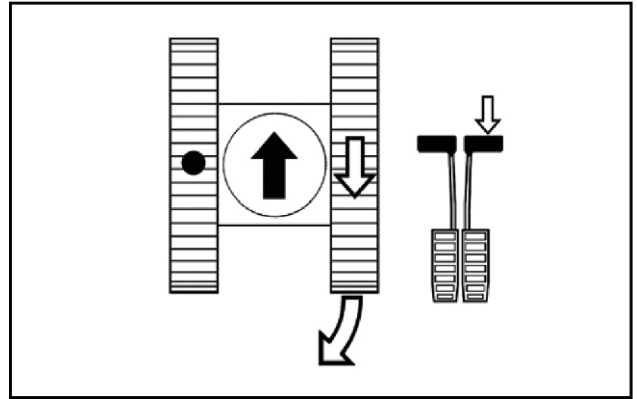

SMIL13CEX2683AB 7

### Turning to the right (reverse travel)

Simply press the left-hand pedal or pull the left-hand lever rearwards.

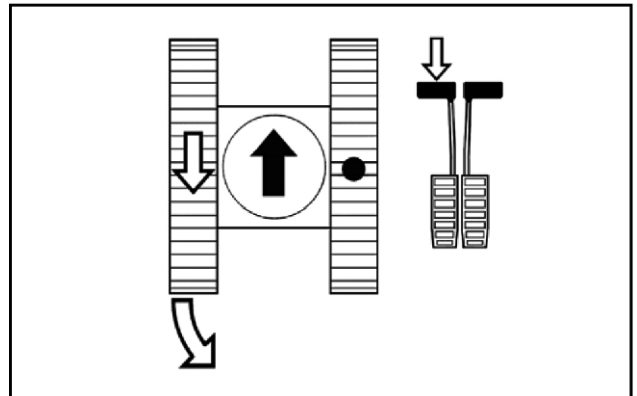

SMIL13CEX2684AB 8

### Turning on the spot, to the right

Press the left-hand pedal or push the left-hand lever forwards and at the same time press the right-hand pedal or pull the right-hand lever rearwards.

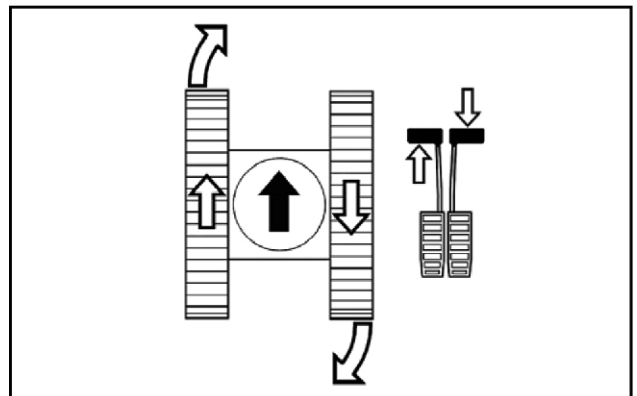

SMIL13CEX2685AB 9

### Turning on the spot, to the left

Press the right-hand pedal or push the right-hand lever forwards and at the same time press the left-hand pedal or pull the left-hand lever rearwards.

**NOTE:** Turning on the spot cannot be done if high speed travel mode is selected.

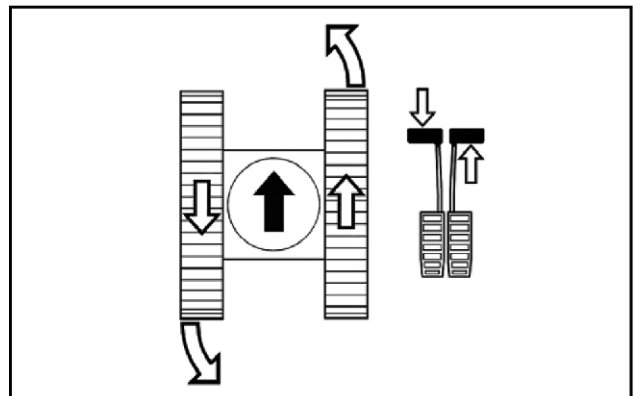

SMIL13CEX2686AB 10

## Gradual turn on the move

Press one of the pedals or push one of the levers and, at the same time, press the other pedal or push the other lever in the same direction, but slightly harder.

## Stopping travel

To come to a complete halt, simply release the levers or pedals and they will return to neutral.

**NOTICE:** Allow as much time as possible to stop the machine.

**NOTICE:** Avoid abrupt stopping as much as practicable.

**NOTICE:** Park or stop the machine on level solid ground in safe area.

## Cautions for traveling

1. Start traveling operation after checking location of the travel unit before commencing travel operation.
2. Select ground as flat and solid as possible for traveling.
3. Travel bypassing obstructions.

**NOTICE:** when using wide shoes avoid traveling on rough ground. Wider shoes tend to cause deformation or crack of the shoes.

4. Travel with decreased traveling speed on rough ground.
5. Encourage a large turn for changing direction and avoid abrupt pivoting turns or spinning turns as much as possible.
6. Check the route to travel in advance.
7. Prepare a personnel to signal operator whenever moving the machine in a location with poor visibility. Pay attention to permissible weight of bridge when crossing the bridge.
8. Take necessary measure such as placing plates so as not to damage surface of paved road.
9. Slow down and loosen tension of the track shoes when traveling on place with gravels and cobbles.

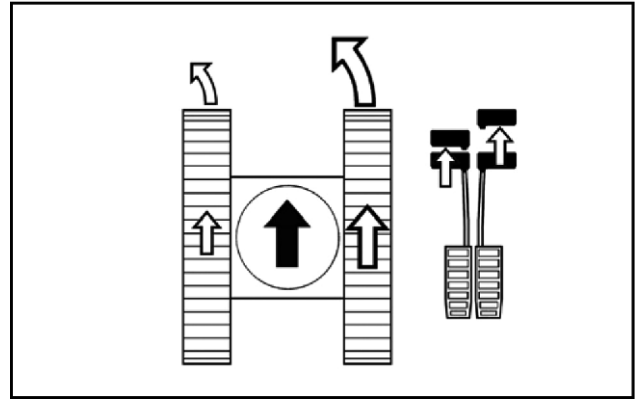

SMIL13CEX2687AB 11

## Parking the unit

### Parking the machine

#### **▲ WARNING**

**Fall hazard!**

Jumping on or off the machine could cause an injury. Always face the machine, use the handrails and steps, and get on or off slowly. Maintain a three-point contact to avoid falling: both hands on the handrails and one foot on the step, or one hand on the handrail and both feet on the steps. Failure to comply could result in death or serious injury.

W0141A

1. Park the machine on a hard and level ground, and orient the upper structure frame parallel to the undercarriage.
2. Operate the boom, arm, and attachment controls so that the arm stands vertical and the attachment rests on the ground.
3. Set the gate lock lever (1) to central position (B) (the safety bar (2) is in inward position).

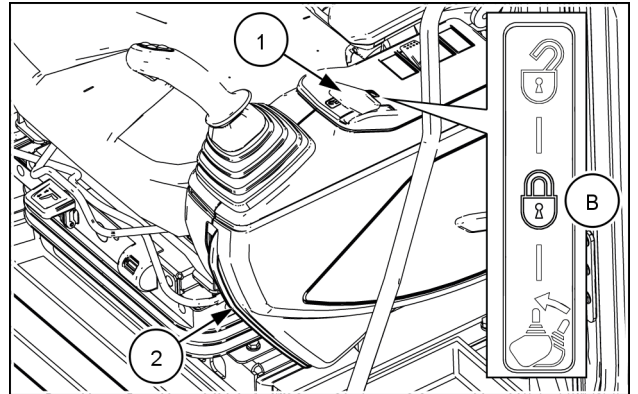

SMIL22CEX1957AA 1

4. Turn the engine throttle (3) to low idle position.
5. Wait for the green cooling down icon to appear.



The engine has cooled down and can be stopped.

**NOTICE:** If the engine is stopped before the icon appears, the lubricated section on the turbocharger gets dried from the high heat, leading to a turbocharger failure.

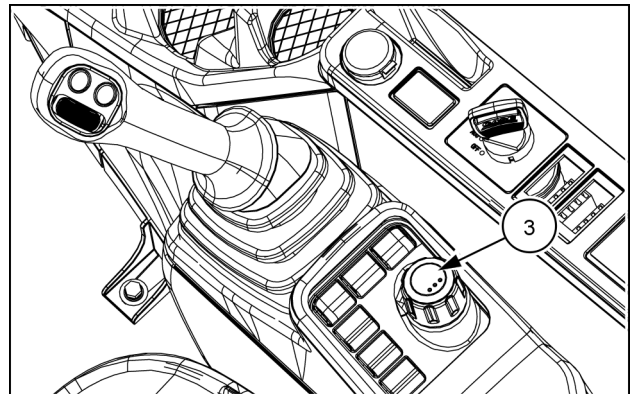

SMIL21CEX3158AA 2

6. Turn the starter key (4) to OFF position.

**NOTE:** If the security function is set up, the option for activating the security function is displayed.

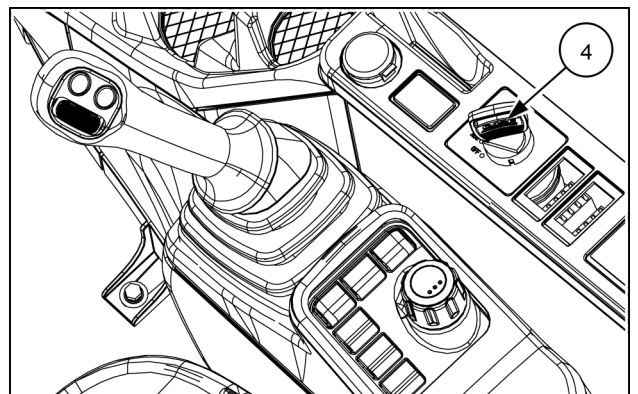

SMIL21CEX3158AA 3

7. Remove the starter key, get off the cab and lock the cab door. Check that the hood and the side doors are properly locked, and that the lower panels are properly fixed.

**NOTE:** Make sure that any portion of the machine is interfering public road. Install appropriate traffic signs if any portion interferes public road.

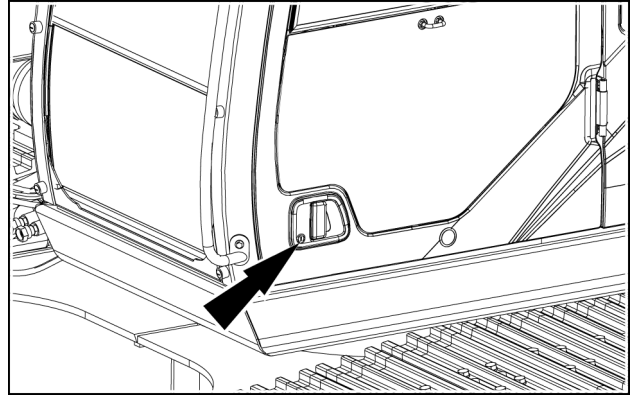

SMIL21CEX3220AA 4