



ENGINE

Make	FPT
Model	F4HFE413Z*V005
Emissions Certification	TIER 4 FINAL/ STAGE V CERTIFIED
Type	Water-cooled, 4-cycle diesel, high pressure common rail system – electronic control. Fixed geometry turbocharger w/ air cooled intercooler, ATS, EGR-free
Cylinders	4-cylinder in-line
Bore/Stroke	4.09 x 5.20 in (104 x 132 mm)
Displacement	275 in ³ (4.5 L)
Fuel	#2 Diesel, #1 and #2 mixture permitted for cold temperatures
Fuel injection	Direct injection – electronic
Fuel filter	Replaceable, full flow spin-on cartridge
Air filter	2-element dry type w/ warning restriction indicator
Mid-mount cooling module w/ auto reversing fan:	Mid-mount air/water
Fan – hydraulic driven:	
Style	8 blade puller
Diameter	28 in (711 mm)
Water pump	Integral
Engine oil pump operating angle ratings:	
Side-to-side	35°
Fore and aft	35°
Oil filtration	Replaceable, full flow spin-on cartridge
Engine speeds	RPM
Rated – full load	2000
Horsepower – Maximum Power:	
Peak gross @ 1800 RPM	142 hp (106 kW)
Net rated @ 2000 RPM	130 hp (97kW)
Peak net @ 1800 RPM	133 hp (99kW)
Torque – Maximum Power:	
Gross @ 1600 RPM	451 lb-ft (612 N-m)
Net @ 1600 RPM	432 lb-ft (586 N-m)
Net torque rise:	
Maximum power range	27%

NOTE: Gross horsepower and torque per SAE J1995.
Net horsepower and torque per SAE J1349.

DRIVETRAIN

Transmission:	4F/3R Proportional w/ Electronic Control Module torque sensing autoshift/manual shift and modulation	
Gears	Helical cut	
Gear ratios – 4-speed	Forward/Reverse	
1st	4.012/3.804	
2nd	2.174/2.061	
3rd	1.088/1.031	
4th	0.619/ –	
Torque converter:		
Stall ratio – 4-speed	2.30:1	
Differential:		
Limited slip w/ 67% of available axle torque to wheel w/ traction		
Rear axle oscillation	24° total	
Front and rear axles:		
Differential ratio	3.364	
Planetary ratio	6.4	
Final axle ratio	21.53	
Heavy-duty axles – optional:		
Front axle equipped w/ locking differential		
Rear axle equipped w/ open differential		
Planetaries	Outboard	
Service brakes:		
Hydraulically actuated, maintenance-free, multiple wet disc w/ accumulator to all four wheels		
Brake surface area:		
Front hub – each	480 in ² (0.31 m ²)	
Rear hub – each	480 in ² (0.31 m ²)	
Parking brakes:		
Spring-applied hydraulic release disc on transmission output shaft neutralizes power flow to wheels when engaged		
Travel speeds – 4-speed transmission:	Forward	Reverse
	mph (kph)	mph (kph)
1st	3.8 (6.1)	4.0 (6.4)
2nd	6.9 (11.1)	7.3 (11.7)
3rd	13.4 (21.6)	14.1 (22.8)
4th	22.3 (35.9)	–

NOTE: Travel speeds at full engine throttle
w/ 17.5 x 25 L3 tires.

ELECTRICAL

Voltage	24 Volts, negative ground
Alternator	70 amp
Batteries (2)	12-volt

OPERATOR ENVIRONMENT

ROPS cab AC w/ heat; 8" LCD touchscreen display, adjustable armrest w/ 3 configurable buttons; Key start; Articulated power steering w/ tilt column; Fully adjustable, suspension seat w/ headrest; Foot throttle with throttle set feature; Single lever (joystick) loader control w/ auxiliary function and fully adjustable wrist rest, 2 cup holders; Interior rear view mirror; 3" High Visibility Seat belt Orange retractable seat belt; Integrated LED rotating beacon; Multiple storage trays; Single brake pedal; F/N/R shuttle switch; Left and Right external rear view mirrors; Pressurized air filtering; Anti-glare window strip; Front and Rear Defroster; Side window, partial/fully open; 2 Dome lights; Wipers, rear and intermittent front; Windshield washers, front and rear; Rubber floor mat; Horn; Radio ready – Includes antenna, speakers, wiring, radio fuse, 20A converter, 12-volt auxiliary power outlet, and USB outlet.

Display/Gauges:

Digital:

Transmission oil temperature; Engine coolant temperature; Fuel level; DEF level.

LCD screen:

Hour meter; Time; FNR indicator; Trip computer A/B; Differential lock; Engine speed; Automatic transmission indicator; DeClutch indicator; Fuel consumption; Engine diagnostics; Error reporting; Travel speed; Gear selection; Engine mode indicator; Transmission diagnostics; DEF – Diesel Exhaust Fluid gauge.

Audible/Visual alarms:

Warning lights:

Four way flashers and turn signals;
Lamp/High Beam Indication;
Engine Block Heater.

Caution warnings:

Parking brake; Coolant temperature;
Hydraulic oil temperature; Transmission
oil temperature; Air filter; Transmission
filter; Hydraulic filter; Alternator; Low fuel.

Critical warnings:

Engine oil pressure; Brake pressure; Steering
pressure - w/ aux. steering*; Coolant
temperature; Hydraulic oil temperature;
Transmission oil temperature.

Backup alarm

Maintenance reminders:

Cab air filter; Engine oil filter; Fuel pre-filter;
DEF tank vent filter; SCR supply filter;
Hydraulic oil and filter; Engine air filter;
Engine coolant; Drive belt; Cab recirculation
filter; Engine breather filter; Transmission
breather; Front and rear axle fluid; SCR
supply module filter.

NOTE: *If equipped w/ option.

OPERATING WEIGHT

Z-Bar
Unit equipped w/ ROPS cab w/ heater and A/C;
Standard heavy counterweight; 17.5-R25 L3
Radial tires; 2.1 yd³ (1.6 m³) pin-on w/ bolt on
edge; Full fuel; Full DEF; 165 lb (75 kg) operator:
24,203 lb (10 978 kg)

XT
Unit equipped w/ ROPS cab w/ heater and A/C;
Standard heavy counterweight; 17.5-R25 L3
Radial tires; 2.1 yd³ (1.6 m³) ACS loader bucket
w/ bolt on edge; Standard batteries; Full fuel;
165 lb (75 kg) operator:
25,834 lb (11 718 kg)

XR
Unit equipped w/ ROPS cab w/ heater and A/C;
Standard heavy counterweight; 17.5-R25 L3
Radial tires; Front and rear fenders; 2.1 yd³
(1.6 m³) general purpose loader bucket w/ edge;
Full fuel; 165 lb (75 kg) operator:
24,485 lb (11 106 kg)

HYDRAULICS

Pump – steering/implement:
Closed center pressure/flow compensated

Variable displacement – load-sensing:
35.4 gpm @ 2000 RPM
(134 L/min @ 2000 RPM)

Loader control valve:
Closed-center, sectional 2, 3 or 4-function
w/ control for lift, tilt and auxiliary hydraulics

Loader auxiliary steering:
Hydraulic orbital center-pivot articulating
w/ on-demand oil flow

High pressure standby 3,625 psi (24 993 kPa)

Filtration:
Filtered vent w/ relief on hydraulic reservoir,
maintains 2-8 psi on reservoir, 10-micron, return
filter furnishes only clean oil to all components
of the system

Note: Per ISO 14397, ISO 5998, ISO 5746

SERVICE CAPACITIES

Fuel tank 50.0 gal (189.0 L)

DEF tank – Diesel Exhaust Fluid:
Usable capacity 7.1 gal (26.7 L)
Total 11.7 gal (44.2 L)

Hydraulic system:
Reservoir 15.0 gal (56.8 L)
Total 30.0 gal (113.6 L)

Transmission:
Service w/ filter 27.48 qt (26 L)

Front and rear axle:
Front axle 23.2 qt (22.0 L)
Rear axle 23.2 qt (22.0 L)

Engine oil w/ filter 12.5 qt (11.8 L)

Cooling system 5.8 gal (22.0 L)

OTHER SPECIFICATIONS

Lift cylinder:
Bore diameter 4.00 in (101.6 mm)
Rod diameter 2.25 in (57.2 mm)
Stroke 30.82 in (783.0 mm)

Dump cylinder – Z-Bar and XR:
Bore diameter 4.50 in (114.3 mm)
Rod diameter 2.50 in (63.5 mm)
Stroke 20.84 in (529.3 mm)

Dump cylinders – XT:
Bore diameter 4.00 in (101.6 mm)
Rod diameter 2.25 in (57.2 mm)
Stroke 29.85 in (758.2 mm)

Loader:
Z-Bar loader linkage; Single control for
lift and tilt; Positive hold float; Automatic
return-to-dig; Automatic height control;
Automatic return-to-travel; Brake pedal
transmission disconnect; Bucket position
indicator on bucket.

Cycle time:
Raise w/ rated bucket load 5.4 sec
Dump w/ rated bucket load:
Z-Bar/XR 1.2 sec
XT 2.4 sec
Float down 3.9 sec

Sound level in Cab (LpA) 68 dB(A)
Exterior sound level (LwA) 102 dB(A)

NOTE: Sound level data tested in accordance
with ISO6395, 6396, 3744.

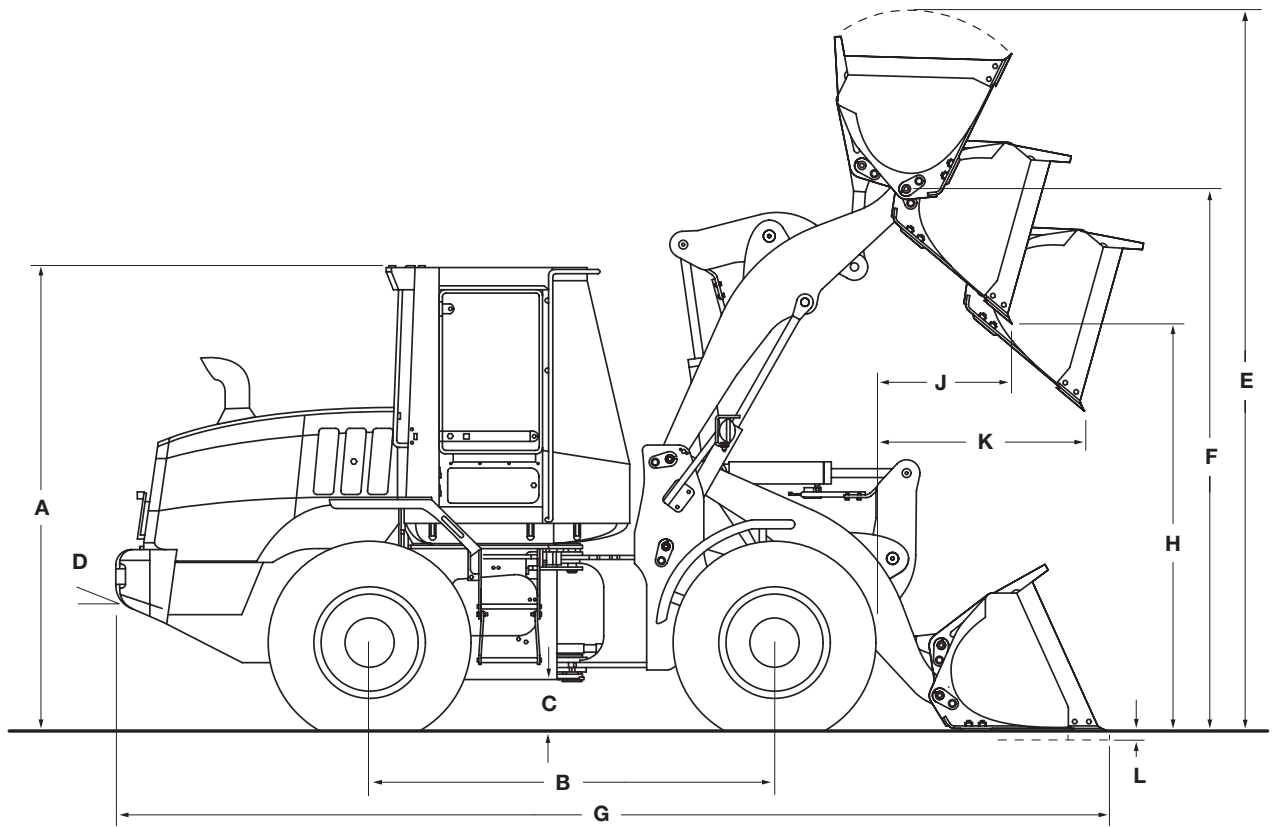

Line drawings are for illustrative purpose only and may not be exact representation of unit.

DIMENSIONS

A. Height to top of ROPS cab	128.9 in (3 275 mm)
Height to drawbar	37.5 in (952 mm)
B. Wheelbase	108.3 in (2 750 mm)
C. Ground clearance	13.4 in (341 mm)
D. Angle of departure	30°
Width:	
Overall* without bucket	96.4 in (2 448 mm)
Tread width	78.7 in (2 000 mm)
Turning radius* – outside	196.9 in (5 002 mm)
Turning angle:	
From center	40°
Total angle	80°
Rear axle oscillation – total	24°

NOTE: *Dimensions taken with 17.5x25 L2 Radial tires. Additional dimensions on pages 4 through 7.

WEIGHT ADJUSTMENTS

Select Options	Weight Adjustment	Tipping Load Adjustment	
		Straight: Deflected	40° Turn: Deflected
17.5 x 25 L2 Bias tires	-632 lb (-287 kg)	-588 lb (-267 kg)	-1,151 lb (-522 kg)
17.5 x 25 L3 Bias tires	-344 lb (-156 kg)	-318 lb (-144 kg)	-784 lb (-356 kg)
17.5-R25 XHA TL (L2 Radial) tires	-168 lb (-76 kg)	-188 lb (-85 kg)	-181 lb (-82 kg)
20.5-R25 L2 Bias tires	+220 lb (+100 kg)	+142 lb (+64 kg)	-159 lb (-72 kg)
20.5-R25 L2 Radial tires	+556 lb (+252 kg)	+366 lb (+166 kg)	+316 lb (+144 kg)
20.5-R25 L3 Radial tires	+812 lb (+368 kg)	+609 lb (+276 kg)	+538 lb (+244 kg)
20.5-R25 Snow Radial tires	+680 lb (+308 kg)	+447 lb (+203 kg)	+389 lb (+177 kg)

NOTE: Tires inflated to 50 psi (345 kPa) in the front and 40 psi (275 kPa) in the rear.

**Unit equipped with Z-Bar loader arms, 2.1 yd³ (1.61 m³) general purpose pin on bucket with bolt-on edge, 17.5x25 L3 Radial tires, ROPS cab with heater and air conditioner, heavy counterweight, standard batteries, front and rear fenders, full fuel and 165 lb (75 kg) operator. Adjust select options from rated weight.

PERFORMANCE SPECS

521G Z-Bar*		2.1 yd³ (1.6 m³) Bucket with Bolt-on Edge - Pin On	2.0 yd³ (1.5 m³) Bucket with Teeth - Pin On	2.1 yd³ (1.6 m³) Bucket with Bolt-on Edge - JRB Coupler	2.0 yd³ (1.5 m³) Bucket with Teeth - JRB Coupler
Operating weight		24,203 lb (10 978 kg)	24,128 lb (10 944 kg)	25,006 lb (11 343 kg)	24,931 lb (11 308 kg)
E. Operating height – fully raised with spillguard		181.6 in (4 613 mm)	181.6 in (4 614 mm)	186.0 in (4 724 mm)	186.0 in (4 724 mm)
F. Hinge pin height – fully raised		142.0 in (3 606 mm)	142.0 in (3 606 mm)	141.9 in (3 605 mm)	141.9 in (3 605 mm)
G. Overall length – bucket level on ground		260.3 in (6 612 mm)	266.0 in (6 755 mm)	269.1 in (6 834 mm)	266.6 in (6 773 mm)
Dump angle – fully raised		55°	55°	55°	55°
H. Dump height – fully raised, 45° dump		108.7 in (2 760 mm)	105.0 in (2 668 mm)	102.8 in (2 612 mm)	104.4 in (2 651 mm)
J. Bucket reach – fully raised, 45° dump		37.9 in (962 mm)	42.0 in (1 067 mm)	43.2 in (1 098 mm)	41.2 in (1 046 mm)
K. Bucket reach – 7 ft 0 in (2.13 m) height, 45° dump		55.8 in (1 418 mm)	58.0 in (1 474 mm)	58.0 in (1 472 mm)	56.8 in (1 443 mm)
L. Dig depth		2.7 in (67 mm)	2.8 in (71 mm)	3.7 in (94 mm)	3.8 in (98 mm)
Operating load – ISO Rigid Tires		8,827 lb (4 004 kg)	8,948 lb (4 059 kg)	7,837 lb (3 555 kg)	7,945 lb (3 604 kg)
Operating load – ISO Deflected Tires		8,080 lb (3 665 kg)	8,191 lb (3 715 kg)	7,153 lb (3 244 kg)	7,253 lb (3 290 kg)
Maximum material density – ISO Rigid Tires		4,203 lb/yd ³ (2 494 kg/m ³)	4,474 lb/yd ³ (2 655 kg/m ³)	3,732 lb/yd ³ (2 214 kg/m ³)	3,973 lb/yd ³ (2 357 kg/m ³)
Maximum material density – ISO Deflected Tires		3,847 lb/yd ³ (2 283 kg/m ³)	4,096 lb/yd ³ (2 430 kg/m ³)	3,406 lb/yd ³ (2 021 kg/m ³)	3,627 lb/yd ³ (2 152 kg/m ³)
Tipping load – ISO Rigid Tires:	Straight	20,100 lb (9 117 kg)	20,364 lb (9 237 kg)	17,951 lb (8 142 kg)	18,186 lb (8 249 kg)
	40° turn	17,653 lb (8 007 kg)	17,896 lb (8 118 kg)	15,673 lb (7 109 kg)	15,890 lb (7 208 kg)
Tipping load – ISO Deflected Tires:	Straight	18,911 lb (8 578 kg)	19,157 lb (8 690 kg)	16,872 lb (7 653 kg)	17,094 lb (7 754 kg)
	40° turn	16,159 lb (7 330 kg)	16,382 lb (7 431 kg)	14,306 lb (6 489 kg)	14,507 lb (6 580 kg)
Lift capacity:	Full height	12,249 lb (5 556 kg)	12,326 lb (5 591 kg)	11,435 lb (5 187 kg)	11,513 lb (5 222 kg)
	Ground	23,635 lb (10 721 kg)	24,540 lb (11 131 kg)	15,664 lb (7 105 kg)	15,898 lb (7 211 kg)
Breakout force with tilt cylinder		20,934 lb (9 495 kg)	22,593 lb (10 248 kg)	16,839 lb (7 638 kg)	21,530 lb (9 766 kg)
Loader clearance circle with bucket		431.7 in (10 966 mm)	435.4 in (11 059 mm)	436.8 in (11 094 mm)	435.8 in (11 070 mm)

521G XR		2.1 yd³ (1.6 m³) Bucket with Bolt-on Edge - Pin On	2.0 yd³ (1.5 m³) Bucket with Teeth - Pin On	2.1 yd³ (1.6 m³) Bucket with Bolt-on Edge - JRB Coupler	2.0 yd³ (1.5 m³) Bucket with Teeth - JRB Coupler
Operating weight		24,485 lb (11 106 kg)	24,409 lb (11 072 kg)	25,288 lb (11 470 kg)	25,212 lb (11 436 kg)
E. Operating height – fully raised with spillguard		196.6 in (4 993 mm)	196.6 in (4 993 mm)	200.9 in (5 104 mm)	200.9 in (5 104 mm)
F. Hinge pin height – fully raised		156.9 in (3 985 mm)	156.9 in (3 986 mm)	156.9 in (3 984 mm)	156.9 in (3 984 mm)
G. Overall length – bucket level on ground		273.9 in (6 958 mm)	279.6 in (7 101 mm)	282.6 in (7 177 mm)	280.1 in (7 115 mm)
Dump angle – fully raised		51°	51°	51°	51°
H. Dump height – fully raised, 45° dump		123.6 in (3 140 mm)	120.0 in (3 047 mm)	117.8 in (2 992 mm)	119.3 in (3 031 mm)
J. Bucket reach – fully raised, 45° dump		36.9 in (937 mm)	41.0 in (1 042 mm)	42.2 in (1 073 mm)	40.2 in (1 020 mm)
K. Bucket reach – 7 ft 0 in (2.13 m) height, 45° dump		67.5 in (1 714 mm)	69.9 in (1 775 mm)	70.0 in (1 778 mm)	68.7 in (1 746 mm)
L. Dig depth		4.0 in (102 mm)	4.2 in (106 mm)	5.1 in (129 mm)	5.2 in (133 mm)
Operating load – ISO Rigid Tires		7,515 lb (3 409 kg)	7,617 lb (3 455 kg)	6,671 lb (3 026 kg)	6,764 lb (3 068 kg)
Operating load – ISO Deflected Tires		6,929 lb (3 143 kg)	7,025 lb (3 186 kg)	6,128 lb (2 780 kg)	6,215 lb (2 819 kg)
Maximum material density – ISO Rigid Tires		3,578 lb/yd ³ (2 123 kg/m ³)	3,808 lb/yd ³ (2 260 kg/m ³)	3,177 lb/yd ³ (1 885 kg/m ³)	3,382 lb/yd ³ (2 007 kg/m ³)
Maximum material density – ISO Deflected Tires		3,300 lb/yd ³ (1 958 kg/m ³)	3,512 lb/yd ³ (2 084 kg/m ³)	2,918 lb/yd ³ (1 731 kg/m ³)	3,107 lb/yd ³ (1 844 kg/m ³)
Tipping load – ISO Rigid Tires:	Straight	17,178 lb (7 792 kg)	17,397 lb (7 891 kg)	15,358 lb (6 966 kg)	15,557 lb (7 057 kg)
	40° turn	15,029 lb (6 817 kg)	15,233 lb (6 910 kg)	13,342 lb (6 052 kg)	13,527 lb (6 136 kg)
Tipping load – ISO Deflected Tires:	Straight	16,267 lb (7 379 kg)	16,476 lb (7 473 kg)	14,520 lb (6 586 kg)	14,710 lb (6 672 kg)
	40° turn	13,858 lb (6 286 kg)	14,049 lb (6 373 kg)	12,256 lb (5 559 kg)	12,429 lb (5 638 kg)
Lift capacity:	Full height	11,128 lb (5 047 kg)	11,203 lb (5 082 kg)	10,327 lb (4 684 kg)	10,403 lb (4 719 kg)
	Ground	20,122 lb (9 127 kg)	20,291 lb (9 204 kg)	17,021 lb (7 720 kg)	17,288 lb (7 842 kg)
Breakout force with tilt cylinder		21,010 lb (9 530 kg)	22,672 lb (10 284 kg)	16,893 lb (7 662 kg)	21,599 lb (9 797 kg)
Loader clearance circle with bucket		444.2 in (11 282 mm)	448.2 in (11 385 mm)	449.8 in (11 426 mm)	448.7 in (11 398 mm)

521G		Z-Bar/XR	Z-Bar/XR	Z-Bar/XR	Z-Bar/XR
Maximum rollback:	Ground	40°/39°	40°/39°	41°/40°	41°/40°
	Carry position	44°/46°	44°/46°	44°/46°	44°/46°
	@ Full height	54°/55°	54°/59°	54°/55°	54°/55°
Maximum grading angle with bucket – back dragging		60°/60°	60°/60°	61°/61°	61°/60°
SAE bucket capacity – struck		1.77 yd ³ (1.35 m ³)	1.67 yd ³ (1.28 m ³)	1.77 yd ³ (1.35 m ³)	1.67 yd ³ (1.28 m ³)
	Heaped	2.10 yd ³ (1.61 m ³)	2.00 yd ³ (1.53 m ³)	2.10 yd ³ (1.61 m ³)	2.00 yd ³ (1.53 m ³)
Bucket width – outside		100.4 in (2 550 mm)	100.9 in (2 563 mm)	100.4 in (2 550 mm)	100.9 in (2 563 mm)
Bucket weight		1,603 lb (727 kg)	1,527 lb (693 kg)	2,406 lb (1 091 kg)	2,330 lb (1 057 kg)

PERFORMANCE SPECS

521G Z-Bar*		2.1 yd³ (1.6 m³) Bucket with Bolt-on Edge - ACS Coupler	2.0 yd³ (1.5 m³) Bucket with Teeth - ACS Coupler
Operating weight		25,117 lb (11 393 kg)	25,041 lb (11 359 kg)
E. Operating height – fully raised with spillguard		184.7 in (4 692 mm)	184.7 in (4 692 mm)
F. Hinge pin height – fully raised		141.9 in (3 604 mm)	141.9 in (3 605 mm)
G. Overall length – bucket level on ground		265.3 in (6 739 mm)	270.9 in (6 882 mm)
Dump angle – fully raised		55°	55°
H. Dump height – fully raised, 45° dump		105.4 in (2 678 mm)	101.8 in (2 586 mm)
J. Bucket reach – fully raised, 45° dump		41.7 in (1 058 mm)	45.8 in (1 163 mm)
K. Bucket reach – 7 ft 0 in (2.13 m) height, 45° dump		57.9 in (1 471 mm)	59.9 in (1 521 mm)
L. Dig depth		2.7 in (69 mm)	2.9 in (72 mm)
Operating load – ISO Rigid Tires		8,070 lb (3 661 kg)	8,146 lb (3 695 kg)
Operating load – ISO Deflected Tires		7,354 lb (3 336 kg)	7,478 lb (3 369 kg)
Maximum material density – ISO Rigid Tires		3,843 lb/yd ³ (2 280 kg/m ³)	4,073 lb/yd ³ (2 417 kg/m ³)
Maximum material density – ISO Deflected Tires		3,502 lb/yd ³ (2 078 kg/m ³)	3,714 lb/yd ³ (2 204 kg/m ³)
Tipping load – ISO Rigid Tires:	Straight	18,492 lb (8 388 kg)	18,652 lb (8 460 kg)
	40° turn	16,140 lb (7 321 kg)	16,291 lb (7 390 kg)
Tipping load – ISO Deflected Tires:	Straight	17,358 lb (7 873 kg)	17,514 lb (7 944 kg)
	40° turn	14,709 lb (6 672 kg)	14,856 lb (6 739 kg)
Lift capacity:	Full height	11,330 lb (5 139 kg)	11,407 lb (5 174 kg)
	Ground	18,132 lb (8 224 kg)	18,780 lb (8 519 kg)
Breakout force with tilt cylinder		18,096 lb (8 208 kg)	19,364 lb (8 783 kg)
Loader clearance circle with bucket		434.5 in (11 037 mm)	438.3 in (11 133 mm)

521G XR		2.1 yd³ (1.6 m³) Bucket with Bolt-on Edge - ACS Coupler	2.0 yd³ (1.5 m³) Bucket with Teeth - ACS Coupler
Operating weight		25,399 lb (11 521 kg)	25,323 lb (11 486 kg)
E. Operating height – fully raised with spillguard		199.7 in (5 071 mm)	199.7 in (5 071 mm)
F. Hinge pin height – fully raised		156.9 in (3 984 mm)	156.9 in (3 984 mm)
G. Overall length – bucket level on ground		278.9 in (7 085 mm)	284.6 in (7 228 mm)
Dump angle – fully raised		51°	51°
H. Dump height – fully raised, 45° dump		120.4 in (3 058 mm)	116.7 in (2 965 mm)
J. Bucket reach – fully raised, 45° dump		40.7 in (1 033 mm)	44.8 in (1 138 mm)
K. Bucket reach – 7 ft 0 in (2.13 m) height, 45° dump		69.7 in (1 772 mm)	72.0 in (1 829 mm)
L. Dig depth		4.1 in (104 mm)	4.2 in (108 mm)
Operating load – ISO Rigid Tires		6,838 lb (3 102 kg)	6,905 lb (3 132 kg)
Operating load – ISO Deflected Tires		6,273 lb (2 845 kg)	6,340 lb (2 876 kg)
Maximum material density – ISO Rigid Tires		3,256 lb/yd ³ (1 932 kg/m ³)	3,456 lb/yd ³ (2 049 kg/m ³)
Maximum material density – ISO Deflected Tires		2,987 lb/yd ³ (1 772 kg/m ³)	3,170 lb/yd ³ (1 881 kg/m ³)
Tipping load – ISO Rigid Tires:	Straight	15,750 lb (7 144 kg)	15,891 lb (7 208 kg)
	40° turn	13,676 lb (6 203 kg)	13,811 lb (6 264 kg)
Tipping load – ISO Deflected Tires:	Straight	14,874 lb (6 747 kg)	15,014 lb (6 810 kg)
	40° turn	12,546 lb (5 691 kg)	12,679 lb (5 751 kg)
Lift capacity:	Full height	10,215 lb (4 633 kg)	10,290 lb (4 668 kg)
	Ground	18,802 lb (8 528 kg)	18,937 lb (8 590 kg)
Breakout force with tilt cylinder		18,162 lb (8 238 kg)	19,433 lb (8 815 kg)
Loader clearance circle with bucket		447.3 in (11 362 mm)	451.4 in (11 467 mm)

521G		Z-Bar/XR	Z-Bar/XR
Maximum rollback:	Ground	40°/39°	40°/39°
	Carry position	44°/46°	44°/46°
	@ Full height	54°/55°	54°/55°
Maximum grading angle with bucket – back dragging		60°/60°	62°/61°
SAE bucket capacity – struck		1.77 yd ³ (1.35 m ³)	1.67 yd ³ (1.28 m ³)
Heaped		2.10 yd ³ (1.61 m ³)	2.00 yd ³ (1.53 m ³)
Bucket width – outside		100.4 in (2 550 mm)	100.9 in (2 563 mm)
Bucket weight		2,517 lb (1 141 kg)	2,441 lb (1 107 kg)

PERFORMANCE SPECS

521G XT		2.1 yd³ (1.6 m³) Bucket with Bolt-on Edge - JRB Coupler**	2.0 yd³ (1.5 m³) Bucket with Teeth - JRB Coupler**	2.1 yd³ (1.6 m³) Bucket with Bolt-on Edge - ACS Coupler***	2.0 yd³ (1.5 m³) Bucket with Teeth - ACS Coupler***
Operating weight		25,404 lb (11 523 kg)	25,328 lb (11 489 kg)	25,834 lb (11 718 kg)	25,765 lb (11 687 kg)
E. Operating height – fully raised with spillguard		188.4 in (4 786 mm)	188.4 in (4 786 mm)	196.2 in (4 984 mm)	193.8 in (4 923 mm)
F. Hinge pin height – fully raised		147.3 in (3 743 mm)	147.4 in (3 743 mm)	147.3 in (3 742 mm)	147.3 in (3 742 mm)
G. Overall length – bucket level on ground		274.0 in (6 960 mm)	279.7 in (7 103 mm)	269.6 in (6 848 mm)	275.2 in (6 991 mm)
Dump angle – fully raised		57°	57°	57°	57°
H. Dump height – fully raised, 45° dump		102.0 in (2 590 mm)	98.3 in (2 497 mm)	106.1 in (2 695 mm)	102.5 in (2 603 mm)
J. Bucket reach – fully raised, 45° dump		40.6 in (1 031 mm)	44.7 in (1 136 mm)	46.1 in (1 171 mm)	50.3 in (1 277 mm)
K. Bucket reach – 7 ft 0 in (2.13 m) height, 45° dump		55.0 in (1 396 mm)	56.7 in (1 440 mm)	62.9 in (1 598 mm)	64.9 in (1 650 mm)
L. Dig depth		10.0 in (254 mm)	10.2 in (258 mm)	3.3 in (84 mm)	3.4 in (87 mm)
Operating load – ISO Rigid Tires		7,260 lb (3 293 kg)	7,358 lb (3 338 kg)	7,507 lb (3 405 kg)	7,574 lb (3 436 kg)
Operating load – ISO Deflected Tires		6,640 lb (3 012 kg)	6,731 lb (3 053 kg)	6,801 lb (3 085 kg)	6,867 lb (3 115 kg)
Maximum material density – ISO Rigid Tires		3,457 lb/yd ³ (2 051 kg/m ³)	3,679 lb/yd ³ (2 183 kg/m ³)	3,575 lb/yd ³ (2 121 kg/m ³)	3,787 lb/yd ³ (2 247 kg/m ³)
Maximum material density – ISO Deflected Tires		3,162 lb/yd ³ (1 876 kg/m ³)	3,366 lb/yd ³ (1 997 kg/m ³)	3,239 lb/yd ³ (1 922 kg/m ³)	3,433 lb/yd ³ (2 037 kg/m ³)
Tippling load – ISO Rigid Tires:	Straight	16,651 lb (7 553 kg)	16,862 lb (7 648 kg)	17,259 lb (7 829 kg)	17,400 lb (7 893 kg)
	40° turn	14,520 lb (6 586 kg)	14,716 lb (6 675 kg)	15,014 lb (6 810 kg)	15,149 lb (6 871 kg)
Tippling load – ISO Deflected Tires:	Straight	15,671 lb (7 108 kg)	15,871 lb (7 199 kg)	16,130 lb (7 317 kg)	16,269 lb (7 380 kg)
	40° turn	13,279 lb (6 023 kg)	13,463 lb (6 107 kg)	13,602 lb (6 170 kg)	13,734 lb (6 229 kg)
Lift capacity:	Full height	10,433 lb (4 732 kg)	10,565 lb (4 792 kg)	10,560 lb (4 790 kg)	10,653 lb (4 832 kg)
	Ground	22,734 lb (10 312 kg)	22,724 lb (10 307 kg)	24,924 lb (11 305 kg)	24,908 lb (11 298 kg)
Breakout force with tilt cylinder		21,227 lb (9 629 kg)	22,556 lb (10 231 kg)	20,302 lb (9 209 kg)	21,531 lb (9 766 kg)
Loader clearance circle with bucket		432.2 in (10 977 mm)	435.0 in (11 049 mm)	428.4 in (10 880 mm)	431.5 in (10 960 mm)

521G

Maximum rollback:	Ground	57°	57°	57°	57°
	Carry position	59°	59°	59°	59°
	@ Full height	64°	64°	64°	64°
Maximum grading angle with bucket – back dragging		61°	63°	61°	62°
SAE bucket capacity – struck		1.77 yd ³ (1.35 m ³)	1.67 yd ³ (1.28 m ³)	1.77 yd ³ (1.35 m ³)	1.67 yd ³ (1.28 m ³)
Heaped		2.10 yd ³ (1.61 m ³)	2.00 yd ³ (1.53 m ³)	2.10 yd ³ (1.61 m ³)	2.00 yd ³ (1.53 m ³)
Bucket width – outside		100.4 in (2 550 mm)	100.9 in (2 563 mm)	100.4 in (2 550 mm)	101.4 in (2 575 mm)
Bucket weight		2,225 lb (1 009 kg)	2,149 lb (975 kg)	2,655 lb (1 204 kg)	2,586 lb (1 173 kg)

NOTE: *Z-Bar performance data shown with full counterweight

**XT lift arm with bucket for Case coupler

***XT lift arm with buckets for ACS Pro Series 2000® size 30 HD coupler.

Performance data unit equipped with 17.5x25 L2 Radial tires, ROPS cab with heater and air conditioner, full counterweight, standard batteries, front and rear fenders, full fuel and 165 lb (75 kg) operator. Specifications per SAE J732, J1234, J695, J742 and J818.

STANDARD EQUIPMENT

OPERATOR ENVIRONMENT

See page 1

ENGINE

CASE/FPT F4HFE413Z*V005
TIER 4 FINAL/STAGE V CERTIFIED
SCR, DOC & SCRof
Selectable work modes:
 Maximum Mode
 Smart Mode
Turbocharger
Charge air cooling
Automatic fan belt tensioner
Integral engine oil cooling
Fuel filter with water trap
Dual-element dry-type air cleaner
Hydraulic-driven cooling fan
Air-cooled radiator
Mid-mounted cooling module with
 hydraulically driven auto reversing fan
Engine block heater
Common rail electronic fuel injection

LOADER

See page 2 – Operating weight,
Other specifications

DRIVETRAIN

4-wheel drive
4F/3R Selectable autoshift /manual
 shift transmission
Electronic Control Module – programmable,
 computer controlled proportional shifting
 with programmable gear selection
Onboard diagnostics
Single lever electronic shift control
F/N/R switch in loader control handle
Downshift button
Torque converter
Outboard planetary axles
Limited-slip differentials
Transmission oil cooler
Brake pedal transmission disconnect
Hydraulic wet disc brakes
Spring-applied hydraulic release parking brake
Limp-Home Mode

HYDRAULICS

Adjustable Electro-hydraulic - EH loader
 control with one auxiliary function and
 3 configurable buttons
Adjustable EH settings:
 Smooth
 Moderate
 Aggressive
Auxiliary hydraulics
Ride Control™ On/Off Auto w/ Adjustable
 speed
Locking hydraulics for hydraulic coupler
EH Parallel Lift
Low-effort steering
Hydraulic driven fan
8 Diagnostic quick couplers
Hydraulic oil cooler

ELECTRICAL

70 amp alternator and voltage regulator
Battery isolator/electrical disconnect
(2) 700 CCA 12-volt batteries
Lights:
 LED rotating beacon
 2 Front driving headlights – high/low beam
 2 Front flood
 2 LED stop and tail lights
 2 Rear flood
 Front and rear turn signal/flash
Centrally located fuse box
 with all electrical circuits protected
Backup alarm
Remote jump start posts

OTHER

Front and rear fenders, partial coverage
External rear view mirrors
Heavy counterweight
Foot Throttle with Throttle Set
Drawbar hitch
Articulation locking bar
Lift arm locking bar
Lift and tie-down points – front/rear
Rear frame side covers
License plate brackets; front bracket
 and lit rear bracket
Rubber steering stops
Grouped remote-mounted ecology drains:
 Engine oil
 Engine coolant
 Hydraulic oil

TELEMATICS

CASE SiteWatch™ Telematics – includes
 hardware and a 5-yr Advanced
 data subscription
SiteConnect Module providing remote
 diagnostics capability

OPTIONAL EQUIPMENT

OPERATOR ENVIRONMENT

Cloth-covered heated air-suspension seat with headrest
Sound Shield noise suppression package
Bluetooth radio, 12V AM/FM with auxiliary input
Cab convenience package:
Rear sun shade, interior mirror, under the seat drawer, coat hook, 12V accessory port, and an ash tray
In cab powered cooler box
In cab accessory mount
RH steps and platform
Rear view camera
External heated rear view mirrors
Front LED driving/headlights
LED front and rear work lights – 4 front, 2 rear

DRIVETRAIN

Heavy-duty axles:
With locking front differential and open/conventional rear differential
Cold weather package:
Heavy-duty batteries (2x 950 CCA)
Fuel heater
Hydraulic oil cooler bypass
Low temperature hydraulic oil
Grid heater

HYDRAULICS

Secondary steering
Integrated Payload System
Tire Pressure Monitoring System
2-spool loader valves with joystick loader control
4-function loader valve with joystick loader control and two proportional auxiliary roller switches

LOADER

Hydraulic attachment coupler systems
Buckets – see pages 4 through 6
Parallel lift XT
Extended reach XR

TIRES

17.5 x 25 L2 Bias
17.5 x 25 L3 Bias
20.5R25 L2 Radial
20.5R25 L3 Radial

OTHER

12 mph (20 kph) maximum speed control
Special paint
Skid Plate/Transmission guard
Standard fenders with right and left hand steps
Wide full coverage fenders with right and left hand steps

CaseCE.com

©2021 CNH Industrial America LLC. All rights reserved. CASE is a trademark registered in the United States and many other countries, owned by or licensed to CNH Industrial N.V., its subsidiaries or affiliates. CNH Industrial Capital is a trademark in the United States and many other countries, owned by or licensed to CNH Industrial N.V., its subsidiaries or affiliates. Printed in U.S.A. Contains 10% post-consumer fiber.

IMPORTANT: CASE Construction Equipment Inc. reserves the right to change these specifications without notice and without incurring any obligation relating to such change. Availability of some models and equipment builds vary according to the country in which the equipment is used. The illustrations and text may include optional equipment and accessories and may not include all standard equipment. Your CASE dealer/distributor will be able to give you details of the products and their specifications available in your area.



CASE Construction Equipment is biodiesel-friendly. NOTE: All engines meet current EPA emissions regulations. All specifications are stated in accordance with SAE Standards or Recommended Practices, where applicable.



Always read the Operator's Manual before operating any equipment. Inspect equipment before using it, and be sure it is operating properly. Follow the product safety signs and use any safety features provided.

Form No. CCE202407521G
Replaces Form No. CCE202104521G

521G

8 of 8