



CASE
CONSTRUCTION

SSL ATTACHMENTS



INTRODUCTION



MAXIMIZED PERFORMANCE AND UNMATCHED VERSATILITY

In line with our mission to deliver comprehensive product and parts support to our dealers and customers, CASE has introduced a complete solution tailored to meet their unique needs.

Versatility is crucial to maximizing the potential of your machinery. That's why CASE-engineered attachments are specifically designed for our equipment and rigorously tested by our experts.

Each attachment expands your machine's capabilities, enabling you to tackle a wider range of tasks and ensuring peak performance, even in the most demanding applications.



PALLET FORKS

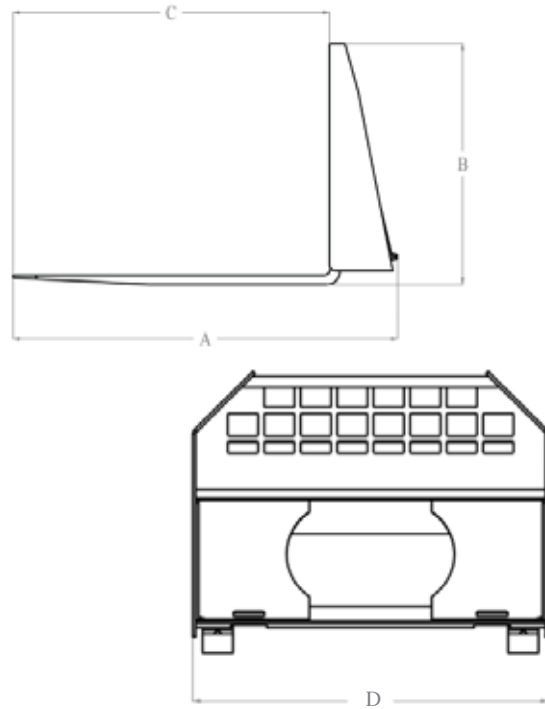

SPECIFICATIONS / FEATURES

- CNH's Pallet Forks are designed with a high strength lightweight frame.
- The Forks are equipped with guard for excellent visibility.
- The lifting capacity of the complete attachment is governed by the operating capacity of the host machine.

CNHI PART NUMBER	Duty	Fork Length (mm) [C]	Load Rating at 500 mm (Kg)	Length (Mm) [A]	Height (mm) [B]	Width (mm) [D]	Weight (kg)
92227013	STD	1220	1200	1485	930	1170	210



COLLECTOR SWEEPER

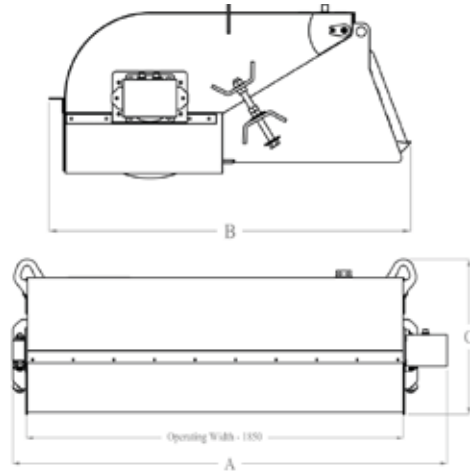

SPECIFICATIONS / FEATURES

- Handles light and heavy-duty clean-up in construction, municipal, and industrial applications
- Bi-directional broom sweeps forward to pick up dirt; reverses to collect asphalt millings, rock, and construction debris
- To dump, just lift and tilt; no chains are required
- No front caster wheel; works easily next to walls, curbs and obstacles
- Replaceable bolt-on cutting edge on bucket
- Mechanical stops to adjust depth of the brush

CNHI PART NUMBER	Hydraulic Flow (LPM)	Hydraulic Pressure (bar)	Capacity (cubic meter)	Brush Diameter (mm)	Operating Width (mm)	Total Width (mm) [A]	Length (mm) [B]	Height (mm)[C]	Weight (kg)
92222672	60-80	210	0.46	660	1850	2120	1500	710	490



4-IN-1 BUCKET

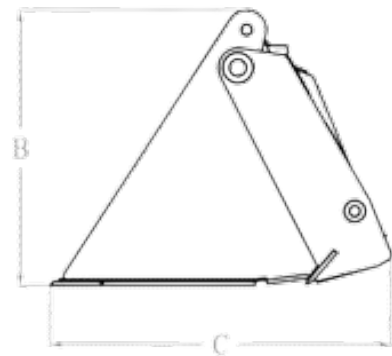
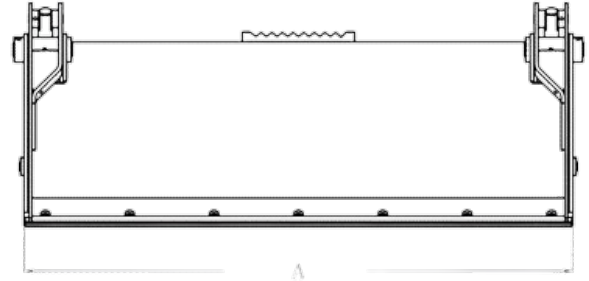

SPECIFICATIONS / FEATURES

- Increases dump height between 800mm and 1200mm
- Heavy Duty Design
- Twin Hydraulic Cylinders
- Cylinders fully enclosed for protection
- Equipped with Bolt on Cutting Edge

CNHI PART NUMBER	Hydraulic Flow (LPM)	Hydraulic Pressure (bar)	Capacity (cubic meter)	Length (Mm) [A]	Height (mm) [B]	Width (mm) [C]	Weight (kg)
92232660	60-80	210	0.3	1545	635	785	265



GRAPPLE BUCKET

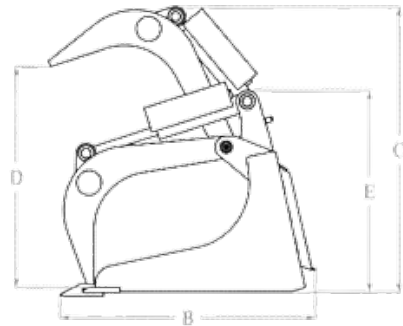
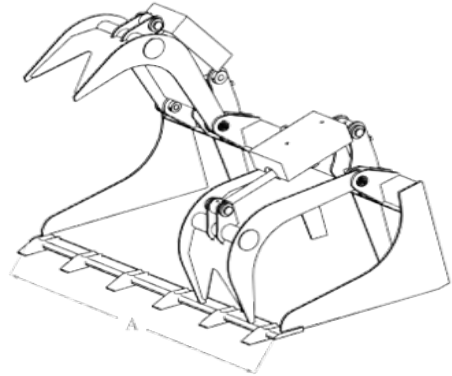

SPECIFICATIONS / FEATURES

- Suitable for demolition and recycling
- Heavy Duty Construction
- Twin Cylinder with ram protection
- Low side allow material wider than bucket to be carried
- Two-piece independent grapples
- Equipped with Tooth Points – 7 Nos

CNHI PART NUMBER	Hydraulic Flow (LPM)	Hydraulic Pressure (bar)	Width (mm) [A]	Length (mm) [B]	Height with Grapple Open (mm)[C]	Grapple Opening (mm) [D]	Height with Grapple Closed (mm)[E]	Weight (kg)
92230959	60-80	210	1525	1035	1160	895	850	350



ANGLE SWEEPER

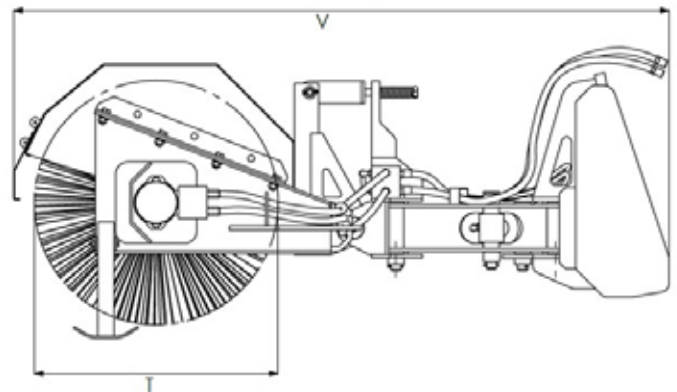
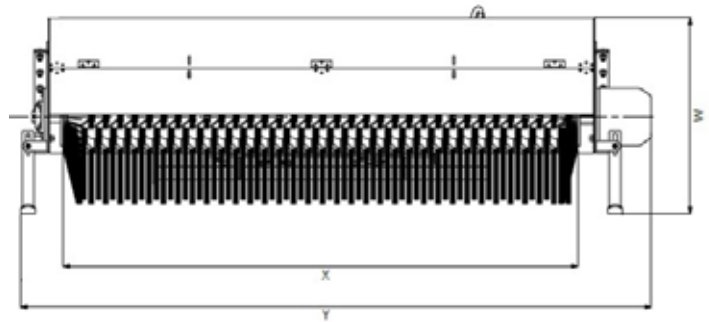

SPECIFICATIONS / FEATURES

- Heavy duty construction
- Large over size bearing
- Adjustable angle 30 deg left, 30 deg right
- Powerful Bi Directional direct drive motor
- Storage legs included
- Great for Agricultural & Snow Clearing applications
- Supplied with Polypropylene Bristles as standard

CNHI PART NUMBER	Total Length (mm) (V)	Height (mm) (W)	Coupling Width (mm) (K)	Brush Diameter (mm) (T)	Total Width (mm) (Y)	Operating Width (mm) (X)	Min & max Oil Flow (Lpm)	Max Oil Pressure (Bar)	Weight (kg)
92251687	1613	674	1162	600	2180	1778	60	190	380



APPLICATIONS

PALLET FORKS

Material Handling: Efficiently transporting pallets, logs, and other heavy items

Loading and Unloading: Assisting with loading trucks or moving materials across a site

Agricultural Applications: Transporting hay bales, feed, and various agricultural products

Construction: Moving building materials such as bricks, blocks, and equipment

Landscaping: Carrying plants, sod, and other materials needed for landscaping projects

COLLECTOR SWEEPER

Municipal & Street Maintenance: Cleans roads, parking lots, and public spaces by removing debris, litter, and dust

Warehouse Cleanup: Keeps warehouse floors clean by sweeping dust, dirt, and small debris, enhancing safety and hygiene

Construction Site Cleanup: Efficiently removes construction debris and materials, ensuring a safe and organized site

Airport & Runway Maintenance: Keeps runways and taxiways clear of debris, ensuring safe aircraft operations

Industrial Facility Maintenance: Maintains clean floors in factories and manufacturing plants, preventing hazards from spills or debris

4-IN-1 BUCKET

Loading and Unloading: The bucket efficiently scoops materials like soil, gravel, or debris for easy transport to other locations

Dozer/Blade Function: Operates like a dozer blade, enabling the operator to push and spread materials with ease

Grapple Function: Ideal for lifting and moving bulk materials such as rocks or gravel, streamlining material handling

Scraper Function: Perfect for site preparation, scraping away topsoil, gravel, or debris to create a clean and level work area

GRAPPLE BUCKET

Material Handling: Grab and lift bulky materials like logs, rocks, or debris, making it ideal for landscaping and construction projects

Waste Management: Collecting and transporting waste materials, such as scrap metal or construction debris, at job sites.

Land Cleaning: Ideal for clearing brush, stumps, and other vegetation, helping prepare land for construction or agriculture

Snow Removal: Gather and move snow, especially in larger quantities

Agriculture and Farming: Handle bales of hay, feed, or other agricultural materials

Demolition Work: They are useful for grabbing and removing demolished materials like bricks, concrete blocks, and beams

ANGLE SWEEPER

Street and Road Cleaning: Perfect for sweeping debris, dirt, and leaves from roads, parking lots, and driveways

Construction Debris Removal: Efficiently removes nails, wood scraps, dirt, and other debris from worksites after construction projects

Warehouse & Industrial Facility Maintenance: Keeps large warehouse floors clean by collecting dust, dirt, and small debris accumulated during daily operations

Airport & Runway Maintenance: Clears debris from runways, taxiways, and aprons, preventing aircraft damage and enhancing safety

Snow Sweeping: Ideal for pushing light snow off driveways, sidewalks, parking lots, and roads, making it a valuable tool for winter maintenance







BUILDING A STRONG CASE.

Since 1842, at CASE Construction Equipment we have lived by an unwavering commitment to build practical, intuitive solutions that deliver both efficiency and productivity.

We continually strive to make it easier for our customers to implement emerging technologies and new compliance mandates.

Today, our global scale combined with our local expertise enables us to keep customers' real-world challenges at the center of our product development.

The vast CASE dealers' network is always ready to support and protect your investment and exceed your expectations, while also providing you with the ultimate ownership experience.

Our goal is to build both stronger machines—and stronger communities. At the end of the day, we do what's right for our customers and our communities so that they can count on CASE.

CaseCE.com

NOTE: Standard and optional fittings can vary according to the demands and specific regulations of each country. The illustrations may include optional rather than standard fittings - consult your Case dealer. Furthermore, CNH Industrial reserves the right to modify machine specifications without incurring any obligation relating to such changes.

Conforms to directive 2006/42/EC

