

| ENGINE | |
|--|---|
| Engine Make | Mahindra & Mahindra |
| Engine Model | 275DI |
| Max. Gross Power (kW/hp) @2200 rpm (ISO 14396) | 18.5/ 25 |
| Displacement (L) | 2.048 |
| Max. Torque (Nm) @1200 rpm (ISO 14396) | 130 |
| Emission level | CEV Emission Stage-V |
| Type of Cooling | Liquid Cooled |
| POWERTRAIN | |
| Max speed (km/hr) | 9.5 |
| Max Gradeability (%) | 35 |
| STEERING | |
| Steering | Hydrostatic (Center Point Articulation) |
| Steering Angle | ±27° |
| Turning Radius (m) | 3.32 |
| Oscillation angle (degree) | ±10° |
| BRAKES | |
| Service Brakes | Hydrostatic |
| Parking Brakes | Spring applied, hydraulically released |
| SERVICE CAPACITIES | |
| Water Tank Capacity (L) | 150 |
| Fuel Tank Capacity (L) | 38 |
| Hydraulic Tank Capacity (L) | 40 |
| Engine Crank Case (L) | 5 |
| Coolant (L) | 6.8 |
| Water spray nozzles | 5 nozzles per drum |
| Water tank material | Plastic |

STANDARD EQUIPMENT

12v Power Socket, 2 Frequency, both Drum or Single Drum Vibration, Sunroof, Horn, Front & Rear Working Lights, Hazard Lights & Parking Lights, Pressurized Water Sprinkler System, 2 Scraper Per Drum, Travel & Vibration Circuit Filter - Tank Mounted Type

SAFETY FEATURES

New Secondary Braking System, Automatic Parking Braking In case Of Engine Shutdown, No Vibration In Neutral, New Radiator Fan Guard

INSTRUMENTATION

Fuel Level Indicators, Hydraulic Oil Level Indicator, Front & Rear Light Switch, New Digital Hour Meter, Drum & Frequency Selection Switch, Engine Coolant Temperature Gauge, Ignition Switch, Neutral Indicator, Battery Charging Indicator, Engine Oil Pressure Indicator, Parking Brake Indicator, Turn & Hazard Indicator, Filter Clogging Indicator

ROPS- Rollover Protection Structure

*Consider operator weight ballasting and total weight of machine.

CIN: U29240DL1998PTC344616
CASE NEW HOLLAND CONSTRUCTION EQUIPMENT (INDIA) PRIVATE LIMITED
 Level-4, Rectangle-1, D-4, District Center, Commercial Complex, Saket, New Delhi - 110017
 Contact No.: 011-66544151
 Email: caseindia@cnhind.com

CaseCE.com 1800 4199 770

Follow us on @caseceindia

NOTE: Standard and optional fittings can vary according to the demands and specific regulations of each country. The illustrations may include optional rather than standard fittings - consult your CASE dealer. Furthermore, CNH reserves the right to modify machine specifications without incurring any obligation relating to such changes.

DISCLAIMER: 2.5% variation on parameters may occur and is acceptable by the industry norms.

| VIBRATION STAGES | |
|---|--------------|
| Vibration stages | Two |
| Frequency High (Hz) | 61 |
| Frequency Low (Hz) | 46 |
| Amplitude (mm) | 0.5 |
| Centrifugal Force (High) - per drum (kgf/kN) | 2900 / 28.43 |
| Centrifugal Force (Low) - per drum (kgf/kN) | 1652 / 16.20 |
| Maximum Applied Force - per drum (kgf/kN) | 4380 / 42.95 |
| OPERATING DATA | |
| Operating weight (kg) | 2900 |
| Front Axle load (kg) | 1480 |
| Rear Axle load (kg) | 1420 |
| Static Linear Load - Front / Rear (kg/cm) | 14.8 / 14.2 |
| DIMENSIONS | |
| A - Wheelbase (m) | 1.925 |
| B - Overall Width (m) | 1.184 |
| C - Rear overhang - Drum Centre to frame edge (m) | 0.535 |
| D1=D2 - Drum Diameter - Front/Rear (m) | 0.700 |
| H1-Total Machine Height (m) | 2.697 |
| H2 - Height to top of seat / Steering wheel (m) | 1.827 |
| K - Ground Clearance (m) | 0.307 |
| L - Total Length (m) | 2.871 |
| O1 - Side Overhang - Drum edge to frame (m) | 0.092 (92mm) |
| S - Drum Thickness (m) | 0.012 (12mm) |
| W1=W2 - Drum Width-Front / Rear (m) | 1.000 |
| F - Curb Clearance (mm) | 560 |

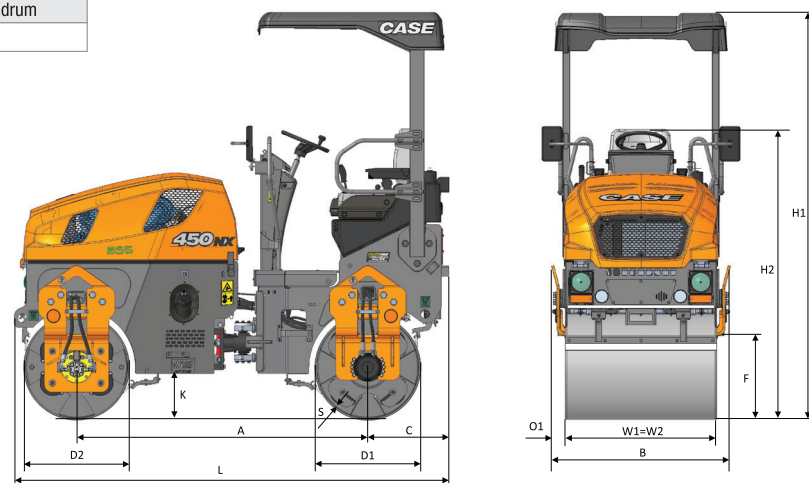

450NX Brochure Version Dated December 2024



CASE
CONSTRUCTION

THE NEW ERA IN CONSTRUCTION EQUIPMENT

Presenting
THE ALL-NEW

450NX

TANDEM VIBRATORY COMPACTOR



SCAN ME

Eco-Friendly, High-Efficiency
Powerful Engine

myCASE
CONSTRUCTION
The New Gen of Telematics

Reliable
Hydraulics



REASONS TO CHOOSE NX SERIES

A LEGACY OF HIGH PERFORMANCE



EFFICIENCY AND RELIABILITY

- Optimized machine weight and repowering with 18.5 KW CEV Stage V engine, with mechanical fuel pump ensures peace of mind
- Intelligent hydraulic system and 25HP engine delivers high efficiency than CEV-V 45hp models.
- Well protected rust proof plastic fuel tank with lockable cap



EXCELLENT SERVICEABILITY

- Single piece openable engine hood with provision to lock
- Engine and all serviceable parts are easily accessible
- Ease of accessibility of Hydraulic pumps, Valve block, from Hood opening.
- Gas strut assisted engine hood for ease of lifting and serviceability



SAFETY ENHANCED

- Two post foldable ROPS structure for better visibility and ease of ingress/egress
- Electro Magnetic Immunity and compliance
- Both sides rear-view mirror
- Excellent visibility of drum edges thanks to optimized width
- New ergonomic footsteps

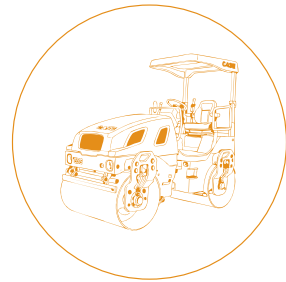

A LEGACY OF HIGH PERFORMANCE & INNOVATION

- Powered by M&M 275DI mechanical engine
- 180+ years of legacy, delivering breakthrough technology
- Compact design for hassle-free maintenance
- High static linear load ensures good mat finish



COMFORTABLE OPERATOR STATION

- New operator station with newly designed controls and speed settings
- Best in class ergonomically designed comfortable seat with adjustable arm rest and high back-rest
- Wide canopy for better sun and rain protection
- High backrest seat with mechanical suspension with adjustments such as weight setting, backrest incline, arm rest position, forward and backward movement.



NEW CONNECTED MACHINES



- Enhanced monitoring and streamlined operations with my CASE Construction Telematics
- Boosted productivity through efficient resource allocation with fleet management
- Improved safety and security with advanced tracking and recovery capabilities
- Real-time data and downtime reduction for superior customer service
- Data-driven decision-making to increase profitability

SMART DESIGN

- Compact contemporary looks
- New robust frame suitable for confined space
- New intuitive instrument cluster with Vandal Guard
- Plastic water tank with strainer/filler for clean water, rust free for lifetime, 150L big size.
- Plastic fuel tanks with strainer and lockable cap, rust free for lifetime, Vandalism protection from all sides. Ground level filling ease.
- The vehicle experiences reduced noise pollution due to the engine fan being positioned at the front
- Fuel level gauge on cluster and low water level sensor
- Standard drum width of 1m for ease of maneuverability

