

MOUNTED TANK DISC DRILL

P2185



Greater precision and efficiency maximize your seeding productivity.

The P2185 single shoot air disc drill leads the pack with a state-of-the-art design that raises the bar to an all-new level of seed placement accuracy and durability. The design focuses on essential agronomic principles that result in better stands, higher yields and more profit for you.

Durable construction and easy adjustments reduce maintenance and downtime. By combining efficiency and accuracy, the New Holland P2185 air disc drill maximizes your productivity.

The P2185 is available in 30- and 40-foot working widths and with spacing of 7.5, 10 and 15 inches.

Features that set the P2185 apart:

Two-point calibration check using scales provides the suggested calibration number, which can be confirmed by the operator.

Standard anti-bridging kit is factory-installed.

Higher ground speeds of 7 to 8 miles per hour, together with widths up to 40 feet, let you cover more acres in a day.



Model	P2185 Mounted Tank Disc Drill					
Width	30'			40'		
Tank Capacity	110 Bu			140 Bu		
Spacing	7.5"	10"	15"	7.5"	10"	15"
# of Ranks	2	2	1	2	2	1
# of Row Units	48	36	24	64	48	32
100% Ballast Frame Weights	Left Wing			Right Wing		
	600 lbs			600 lbs		

Flotation tire options include standard radial tires that are priced economically and high-flotation radial tires for working on softer soils. All tire options include walking beam axles.

Standing calibration is standard.

Optional in-tank and rear-view cameras provide better product-level information and rear visibility while roading.

Increased seed tank capacity improves tendering and seeding productivity. The 40' model features a 140-bu capacity tank while the 30' model features a 110-bu capacity tank.

An improved lid/tank interface prevents debris ingress, and an improved tank/meter interface prevents water ingress.

A seed meter rain shield is standard.

Standard Opti-Row™ Downforce Automation helps you make informed decisions on setting downforce to achieve consistent seed depth.

Closing wheel angle adjust feature accommodates different soil types and conditions.

Spoked, solid, narrow and wide gauge wheels are optional.



The P2185's opener redefines “accuracy.”

The patented parallel link opener design delivers industry-leading seed placement accuracy at higher speeds and over rougher terrain. It ensures best-in-class seed emergence in a variety of soils, seeding depths and field conditions, and in a wide spectrum of tillage practices. In addition, the low-maintenance design allows operators to spend more time where it counts—in the field.



No-tools adjustment

No tools are necessary to adjust depth on these drills. The spring-loaded T-handle on each opener allows you to easily adjust depth from 0 to 3.5 inches. The adjustment range is divided into 14 increments which are labeled for a quick visual reference.

Patented parallel link opener gives the operator maximum productivity and seeding precision. The design allows for optimum seed placement combined with unmatched durability in a wide variety of soil conditions.

3" x 16" or 4.5" x 16" semi-pneumatic, either solid or spoked heavy-duty gauge wheel provides accurate and consistent seed placement.

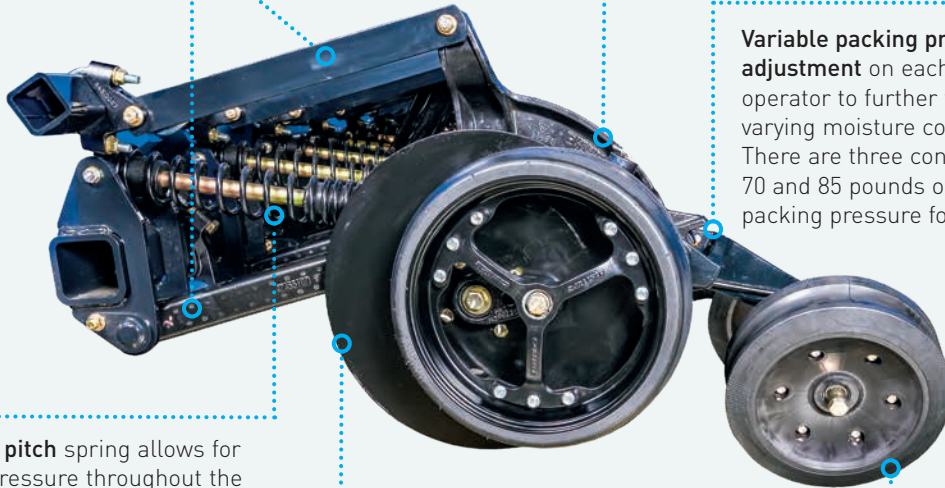

Variable packing pressure range adjustment on each opener allows the operator to further tailor the drill for varying moisture conditions and soil types. There are three convenient settings of 60, 70 and 85 pounds of available variable packing pressure for each row unit.

Patented variable pitch spring allows for consistent down pressure throughout the entire opener operating range, providing the ultimate in terrain following and seed placement.

When the going gets tough the 18-inch disc blade cleanly cuts through the heaviest of crop residue. This ideal disc size reduces residue "hair pinning" and maximizes seed-to-soil contact for ideal seed germination. The discs are also set at a 7-degree angle to open a uniform seed trench where the seed is accurately placed.

A closing system to accommodate all soil conditions—a heavy-duty-rubber, smooth-faced concave 4" x 12" packer wheel is designed specifically for exceptional closing in tough conditions, whether clay, sandy or both types of soils. The double-edge closing wheel follows behind to seal the trench and is effective in a wide variety of soil conditions. The closed trench is essential to providing maximum seed-to-soil contact for uniform germination and plant-stand establishment. The hollow center of the closing system further maintains a smooth field finish and reduces soil compaction.

Forward-facing seed boot provides consistent and accurate seed depth and placement.

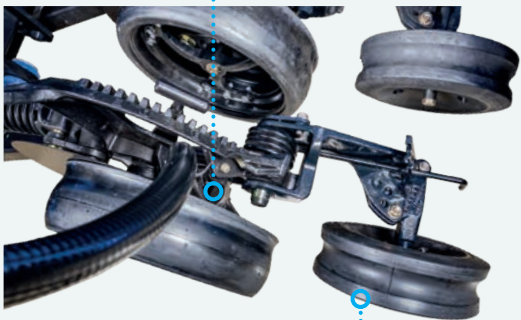

Closing Wheel can be adjusted to 4 different indexed positions—0.5°, 6°, 9° or 13°. A single angle change provides flexibility to accommodate closing various soil conditions.

Compatible with IntelliView™ 12 and IntelliView™ IV Displays

The in-cab display enables operators to easily adjust metering rate, downforce or down pressure, fan speed, and sectional control. Additionally, operators can monitor blockage state on a per row basis from the cab.

IntelliView™ 12 display

IntelliView™ IV display



Automatically controls downforce for seed-depth consistency.



Standard Opti-Row™ Downforce Automation helps you make informed decisions on setting downforce to achieve consistent seed depth for a healthier and more profitable crop.

Load cells on the gauge wheels provide in-cab feedback as percentage of ground contact, adjusting downforce automatically while traveling through the field. The Opti-Row system allows the drill to effortlessly accommodate changing soil conditions and maintain positive contact with the ground, ensuring the row unit is always achieving its set depth.

The system is simple to operate—you don't have to change settings for varying conditions—and reduces component wear by minimizing the force needed to maintain gauge wheel contact.

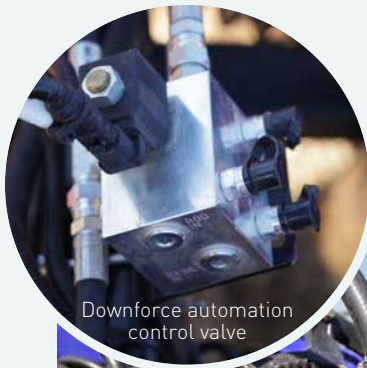

Downforce automation control valve

Automated operation

The Opti-Row system is enabled by three major components: the downforce automation control valve, gauge wheel load sensors, and software that applies the logic needed for automated control. Depending on drill configuration, one or multiple control valves will apply pressure to the rockshaft hydraulic cylinders.



Gauge wheel load sensors

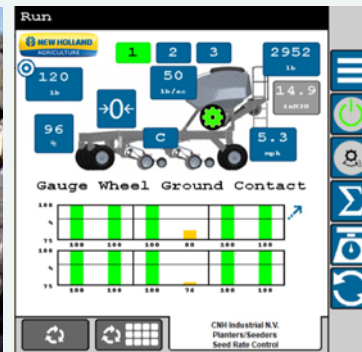

Software

The gauge wheel load sensors are embedded in the depth adjustment T-handles and measure downforce on the gauge wheel. Each sensor is CAN-based rather than analog-based, reducing the need for any intermediate ECUs, and takes a reading ten times per second. The Opti-Row software accounts for depth and wheel position to ensure the correct conversion factor is applied to the load cell readings.

Simple interface

To use Opti-Row downforce automation in the field, the operator simply sets a target downforce and the automated downforce software adds or subtracts pressure on the rockshaft to achieve the target downforce at the gauge wheel. To ensure downforce is set properly, the operator must refer to percent ground contact.

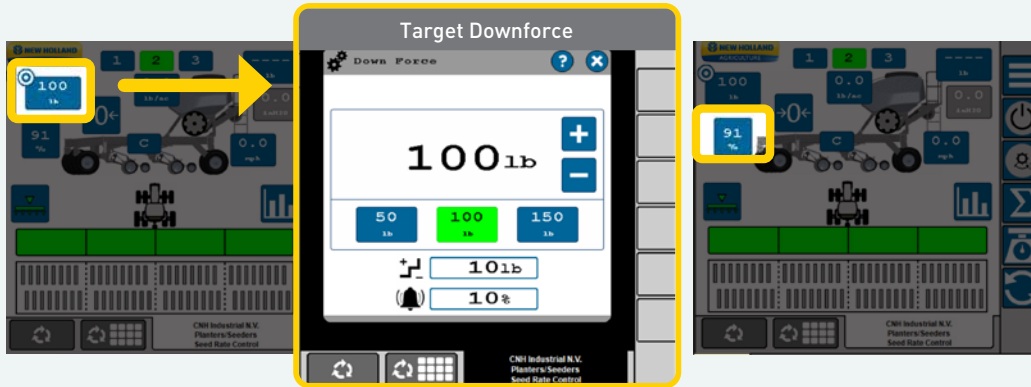

Recommendations for percent ground contact settings:

- Target 90–98% contact
- If readings are consistently 98–100%, decrease target downforce
- If readings are consistently dipping below 90%, increase target downforce

Software ensures accurate depth

Opti-Row software accounts for gauge wheel depth position to ensure the correct conversion factor is applied to the load cell readings. The operator selects the position of the gauge wheel depth handle on the display that corresponds with the position of the gauge wheel depth handle on the drill. It is important that the depth handle position is set correctly in the display to ensure load cell readings are correct. Set the depth handle position in the popup to match the depth set on the row units.

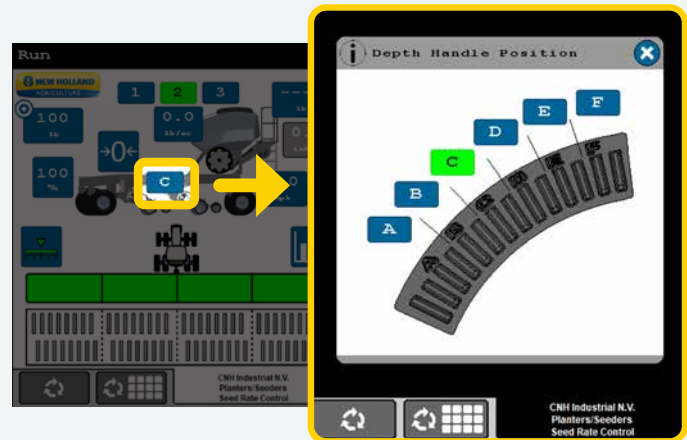

IntelliView™ 12 display

Opti-Row downforce automation metrics can be mapped with an IntelliView™ 12 display, allowing you to visualize disc-drill downforce performance and easily understand how the drill is performing at the field level.

Unmatched durability and lower maintenance costs.

The P2185 single shoot disc drill sets a higher standard for durability. No other model comes close. And durability is the key to reducing your downtime and maintenance costs. How tough are your soil and field conditions? Whether you have rocks, sandy soils or corn stalks, wear and tear is minimized in unforgiving environments.

Durability and reliability:

- **Narrow 18-inch disc** cleanly cuts through the heaviest crop residue
- **Earth Metal® formulated boron steel disc blades** provide unmatched strength and durability in all conditions
- Each opener features a long-life disc scraper with **integral tungsten carbide wear components**
- **Metal sintered bushings** deliver unrivaled durability
- **Sealed double-row main bearing** with integral triple lip seals
- **High-quality, powder-coated** paint finish
- **Cat IV floating hitch** with hardened pins and replaceable bushings

Simple maintenance, easy operation:

- **True 0 to 3.5" depth control settings** with single-handed adjustment
- **In-cab down pressure control** is standard equipment and features three user-defined presets for easy toggling between settings as field conditions change
- **Standard 3-position variable packing pressure**
- **Open frame design** allows easy accessibility and maintenance across the drill



Reduced maintenance and downtime

Maintenance is fast and easy. By removing two bolts and one snap ring, you can access the internal triple-sealed bearings on each opener in less than 30 seconds. In addition, only **two grease points per row unit**—one located on the gauge wheel depth adjuster, the other on the closing wheel arm—significantly reduces maintenance times.



Y splitters on P2185

Toolbar design

The **split rank toolbar** is changed easily to 15 inches on 7.5-inch models, and to 20 inches on a 10-inch model. To change from 7.5- to 15-inch spacing, simply lock out one of the two desired ranks. You can switch product delivery on the P2185 from front, back or to both ranks by simply rotating the Y splitter on each run.

25° Total wing flex

With 25 degrees of total wing flex—15 degrees up and 10 down—the P2185 provides industry-leading ground following to maintain and maximize uniform seed placement over any topography.

Exceptional weight distribution

The P2185 provides exceptional weight distribution that's ideal for a wide range of soils and crops.

Convenient, narrow transport

The 30- and 40-foot models come in a three-section, vertical single-fold configuration that allows easy travel between locations.



Enjoy all the benefits of a mounted seed tank.

The P2185 air disc drill features a mounted seed tank with the capacity needed to get the job done—a roto-molded, non-pressurized-plastic, 110-bushel mounted tank for the 30-foot model and a 140-bushel seed tank for the 40-foot unit.

Improved maneuverability

The mounted seed tank evens weight distribution across the machine to increase maneuverability.

Easy loading

A large platform with easy accessibility and large tank opening makes loading a breeze. In addition, an optional tank fill lighting package is available to assist operator in low light or night fill situations.

Optional weight scales

Tank-mounted weigh scale includes a display on the rear tank platform for unmatched ease of calibration and loading. You'll also operate more efficiently and with less fatigue.

Easy-access meter box

The P2185 meter box is designed specifically for quick adjustment, cleanout and service. Variable-rate seed drive features easy rate adjustment and monitoring through the IntelliView™ 12, IntelliView™ IV or ISO11783-compatible display. Outstanding accessibility also allows you to quickly change meter segments to accommodate a wide range of seeds and crop types. A standard rain shield prevents foreign contaminants and moisture from entering the metering box. In addition, a seed metering agitator minimizes product bridging.



Meter Calibration Check — when equipped with optional weigh scales

- Software feature compares the expected and measured weight change
- Used to detect calibration errors and blockages in the metering system
- 2 separate weight measurements are taken while stationary: initial and final
- 2 types of calibration checks:
 - Quick Check available after 100 lbs of product metered
 - Indicates calibration number error over 18% and provides recommendations
 - Best Check available after 400 lbs of product metered (more accurate check)
 - Indicates calibration number error over 10%
 - Provides ability to UPDATE calibration number

Models		P2185 Mounted Tank Disc Drill	
Toolbar width	ft. (m)	30' [9.1]	40' [12.2]
Transport height	ft. (m)	13'1" [3.99]	13'10" [4.23]
Transport width	ft. (m)	12 [3.65]	18.5 [5.63]
Road-to-opener clearance	in. (cm)	8'6" [21.6]	8'6" [21.6]
Weight 7.5" spacing (empty)	lbs. (kg)	22,890 [10380]	28,360 [12,860]
Weight 10" spacing (empty)	lbs. (kg)	20,890 [9475]	25,660 [11,640]
Weight 15" spacing (empty)	lbs. (kg)	17,790 [8070]	22,380 [10,150]
Length	in. (m)	27'8" [8.43]	29'10" [9.09]
Available spacing	in. (cm)	7.5 [19.1] & 10 [25.4] & 15 [38.1]	
Split rank capability	in. (cm)	15 [38.1]	15 [38.1]
		20 [50.8]	20 [50.8]
Number of row units 7.5" spacing		48	64
Number of row units 10" spacing		36	48
Number of row units 15" spacing		24	32
Minimum tractor PTO hp required 7.5" spacing*		195	260
Minimum tractor PTO hp required 10" spacing*		145	195
Minimum tractor PTO hp required 15" spacing*		98	131
Fold type		Single	Single
Wing sections		3	3
Tires total		16	
Center section walking beam castor tires		380/55R16.5 D ply	
Standard rear mainframe dual walking beam tire size		380/55R16.5 E ply	
High Flotation Rear mainframe dual walking beam tire size		500/40R16.5 E ply	
Inner and outer wings walking beam castor tire size		340/60R15 D ply	
Operating speed	mph (kph)	5-8 [8-12.7]	
Hitch type		Floating	
Ground following design		Parallel link	
Row unit travel from level surface	in. (cm)	8.5 [21.6] up, 11.5 [29.2] down	
Wing flex		15 degrees up, 10 degrees down	
Discs	in. (cm)	18 [45.7] at 7 degrees	
Gauge Wheel Options		3" x 16" or 4.5" x 16" solid or spoked	
Depth settings	in. (cm)	14 position T-handle adjust from 0 to 3.5 [8.9]	
Down pressure adjustment		Variable spring	
Closing wheel variable packing pressure	lbs. (kg)	60, 70 or 85 [27.2, 31.8 or 38.6]	
Standard down pressure control		Opti-Row™ auto downforce	
Hydraulic requirements	gpm (lpm)	30 [114] – 3 remotes	
Mounted seed tank capacity	bushels (l)	110 [3876]	140 [4933]
Display system		Requires an ISO11783 compliant display such as IntelliView™ IV	
Sectional control		4-section metering with overlap control	
Blockage monitoring		Outback blockage	
Optional equipment		High flotation tire option, Hydraulic work switch, Meter roll selection (extra fine, fine, coarse), GPS speed sensor, Packer or Gauge wheel deduct option, Tank mounted weight scales, In-Tank and Rear-View Cameras, Tank fill lighting package, IntelliView™ IV Display	



VALUE, SERVICE AND SOLUTIONS

There's a certain way of thinking that comes from living on a farm. Farming takes equal parts brain and brawn. Not to mention thick skin, calloused hands and a fair share of know how. Seasoned farmers know it helps to have equipment that's built by farmers, sold by farmers and used by farmers.

Support at every step. When you place your confidence in New Holland agricultural equipment, you get the finest in local support. Your New Holland dealer understands the many challenges you face and stands behind you at every step with the equipment, parts, service and financial solutions to make your job easier. Look to New Holland for a complete selection of equipment, including a full line of tractors, hay & forage equipment, harvesting, crop production and material handling equipment.

Quality parts and service. Turn to your New Holland dealer after the sale for expert, factory-trained service and genuine New Holland-branded parts. Your dealer has the very latest service updates and training to ensure your equipment keeps working productively season after season.

Financing solutions. Your New Holland dealer can tell you about smart ways to turn your financial challenges into opportunities with a portfolio of innovative financial services available through CNH Industrial Capital, including customized financing, leasing, insurance and the purchasing convenience of a Commercial Revolving Account.

For reliable equipment, parts and service — or just honest advice on farming and finance — turn to New Holland and your trusted New Holland dealer. We know. We're farmers, too.



Learn more at www.newholland.com



Design, materials and/or specifications are subject to change without notice and without liability therefor. Specifications are applicable to units sold in Canada, the United States, its territories and possessions, and may vary outside these areas.

© 2024 CNH Industrial America LLC. All rights reserved. New Holland is a trademark registered in the United States and many other countries, owned by or licensed to CNH Industrial N.V., its subsidiaries or affiliates. Any trademarks referred to herein, in association with goods and/or services of companies, other than owned by or licensed to CNH Industrial N.V., its subsidiaries or affiliates, are the property of those respective companies.



Safety begins with a thorough understanding of the equipment. Always make sure you and your operators read the Operator's Manual before using the equipment. Pay close attention to all safety and operating decals and never operate machinery without all shields, protective devices and structures in place.