



CASE
CONSTRUCTION

L-SERIES
CRAWLER DOZERS



1150L | 1650L

L-SERIES

CRAWLER DOZERS

POWER AND EFFICIENCY

Drawbar pulling leadership: the hydrostatic transmission and common rail engine deliver best-in-class pulling capacity and controllability. All the working parameters can be customized by the driver for excellent machine controllability and faster cycle times. Productivity boosting electronics: the cab controls offer a wide choice of electronic settings and automated functions that make the driver's job easier. Together with the lowest noise level in the market, they minimise fatigue on long working days. Quick maintenance: the tilting cab provides outstanding accessibility to all main components and enables you to service the L-Series from the ground for any extraordinary maintenance.

FPT INDUSTRIAL ENGINE

The state-of-the-art common rail engine delivers top performance in load response, max torque, power and fuel economy.

The turbocharged engine with an Air-to-Air intercooler relies on well proven multi injection technology to maximize torque back-up and fuel efficiency with reduced engine noise and vibrations.

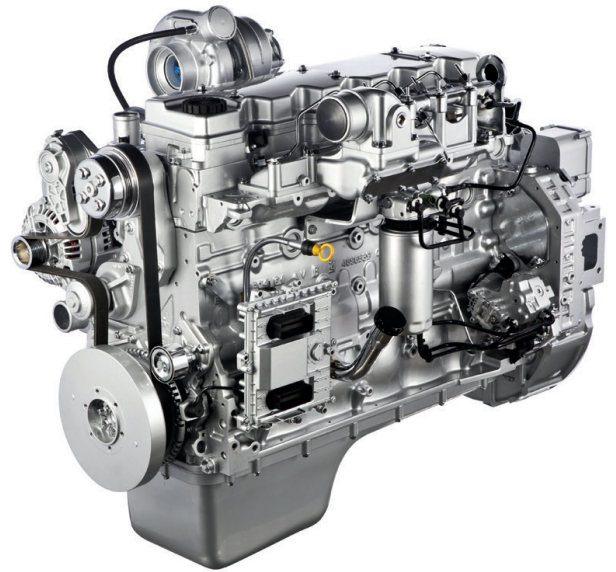

NEVER ENDING POWER

The powerful FPT Industrial engine ensures high torque back-up under load. When the tractive effort grows and the rpm tends to drop, the engine power increases by to 16% to reach 1800 rpm. The result is constant performance and higher pulling capacity. In addition, the ability to work with high torque at lower engine rpm reduces engine wear.



BOOST YOUR PRODUCTIVITY

DUAL PATH HYDROSTATIC TRANSMISSION

The entirely re-engineered transmission offers best-in-class pulling capacity combined with the manoeuvrability typical of the hydrostatic solution. The triple reduction final drives ensure high torque on the ground, reducing the working pressure of the entire system and improving its overall efficiency.

ROBUST UNDERCARRIAGE

The undercarriage featured on Case Crawler Dozers is designed for the toughest environments. Both 1150L and 1650L are available with the XLT tracks, to provide excellent drawbar pull force and perfect dozing and grading accuracy at the same time.



STANDARD PAT BLADE

Thanks to the PAT (Pitch Angle Tilt) blade, operators can do the job faster, more easily and with more comfort, increasing the machine's productivity and its capability to work in very different applications/ environments: it is the ideal solution for this class of dozers, which are used in residential, commercial, utility and roads and bridges site preparation work.

EASY SERVICEABILITY - GROUND ACCESS AND TILTABLE CAB

CASE Dozers are designed to grant ground access to all periodic service and check points, to facilitate maintenance and extend machine life. Furthermore, the tiltable cab provides full accessibility of all main components even for extraordinary service maintenance.

L-SERIES

CRAWLER DOZERS

AGILE AND STRONG

The operator has full control of the massive power of the L-Series Dozers. The electro-hydraulic joystick allows to customise reversing and steering sensitivity for faster and more efficient cycles. The decelerator pedal can be used either to reduce only travel speed or both travel speed and engine rpm.



ADJUSTABLE BLADE PITCH

The low-effort blade hydraulics feature powerful cylinders able to move the blade with ease and control. The mechanical pitch blade can be set between 50 to 60 degrees to suit every dozing application and ground condition.

UNMATCHED VISIBILITY

The L-Series cab is engineered for operator performance, comfort and safety. Thanks to the excellent visibility, the operator can work with confidence and more productively in every operation. The air suspended seat is easy to adjust, providing every operator with a perfect working position. The powerful air conditioning system combined with the best-in-class noise level provide an excellent working environment, reducing operator stress during long working days.





CASE

CASE

3500-1110384

L-SERIES 1150L

CRAWLER DOZERS

ENGINE

Model	FPT Industrial Engine F4HE9684K
Cylinders	6
Displacement	6.7 L
Fuel injection	Direct common rail
Fuel filter	Screw-on, with screen
Cooling	Liquid
Engine speeds	RPM
High idle - no load	2200 +/- 50
Rated - full load	2200
Low idle	800 +/- 25
Horsepower @2200 rpm SAEJ1349	
Net	88 kW
	Imperial 118 hp
	Metric 120 hp
Gross	97 kW
	Imperial 130 hp
	Metric 132 hp
Max torque	589 Nm @ 1400rpm

Engine lubrication

"Forced lubrication" with oil jet piston refrigeration system

Pump operating angle ratings

Side-to-side	45°
Fore and aft	45°

Radiator

Core size area	0.61 m ²
Rows of tubes	4

Fan

Diameter	660 mm
Propeller	Belt mechanical drive

TRANSMISSION COOLING

Type	Heat exchange
Core size	0.54 m ²

ELECTRICAL SYSTEM

Alternator	65 amps
Battery	2X12 V in series, maintenance free, 750 A CCA at -18°

POWERTRAIN

Dual path hydrostatic

Pump	Variable axial piston
Motor	Variable bent axis piston
Max. drawbar pull	214 kN
Transmission	Single lever control electronic tracking
Oil filter	4 micron, spin-on, replaceable

Travel speeds

Forward	0-9.7 km/h
Reverse	0-9.7 km/h

SAHR parking brake

(Spring applied hydraulically released)

Steering brakes	Hydrostatic
Oil Final drive	2 helical gear reductions to planetary reduction

Reduction ratio 61.4:1

HYDRAULICS

Pump Flow@2200 RPM	132 L/min
Max Pressure	207 bar
Lift cylinder PAT	nr.2

Bore diameter	108 mm
Rod diameter	50.8 mm
Stroke	445 mm
Angle cylinder PAT	nr.2
Bore diameter	127 mm
Rod diameter	63.5 mm
Stroke	381 mm
Tilt cylinder PAT	nr.1
Bore diameter	127 mm
Rod diameter	63.5 mm
Stroke	120 mm

BLADE

Variable blade pitch - adjustable	55° to 60°
Lift speed - per second	483 mm
Cutting edge	Reversible, replaceable
Width	200 mm
Length	2158 mm
Thickness	19.1 mm

UNDERCARRIAGE

Track adjustment	Grease injection
Hydraulic frame	Two-tier chassis, manufactured in structural steel
Track link pitch	175.4 mm
Track shoe height	51 mm
Pin diameter	36.6 mm
Bushing diameter	62 mm
Track shoes per side	43
Track rollers per side	7
Carrier rollers per side	2
Track roller rail diameter	190 mm

TRACK ON GROUND

Shoe width	508 mm
Tracks on ground	26323 cm ²

RIPPER

Max. penetration	478 mm
Width	1712 mm
Cut width	1636 mm
Max. ground clearance	424 mm
Max. number of shanks	3
Tooth spacing w/3 teeth	785 mm
Hydraulic cylinder	Double-acting
Diameter	102 mm
Stroke	254 mm
Rod	51 mm

SERVICE CAPACITY

Fuel tank	300 L
Engine oil w/filter	16.4 L
Engine oil w/o filter	15.6 L
Engine cooling system	25.5 L
Hydraulic reservoir	98.4 L
Final drive - per side	14.2 L
Track rollers - each	0.330 L
Front idlers - each	0.460 L
Carrier rollers - each	0.275 L

SPECIFICATIONS

OPERATING WEIGHT

Unit equipped with a cab, full fuel tank, 77 kg operator, frontal pull hook, track guides, PAT blade.

1150L	
Extra Long Tracks (XLT)	13625 Kg
ADD-ON WEIGHTS	
Drawbar	66 Kg
Ripper	1043 Kg
Roller protection	134 Kg

OPERATOR ENVIRONMENT

Cab ROPS/FOPS with air-conditioning - single joystick for speed and direction - adjustable seat upholstered with cloth and air suspension - 50.8mm (2") retractable seatbelt - adjustable arm rests - two foot rests - rear view mirror - three windshield wipers - a dome light - 12 V connector for accessories - Padded roof - floor mats.

Warning lights - Air filter - alternators - failure diagnosis indicator - engine cooling fluid temperature - engine oil pressure - hydraulic filter - low fuel - emergency brake on - maintenance service indicator - transmission filter - transmission load pressure.

Indicators - Battery voltage - fuel level - digital hour meter/tachometer /diagnosis/service reminder - transmission oil temperature-transmission speed indicator - cooling fluid temperature

Audible alarms - Engine cooling fluid temperature - engine oil pressure - low fuel - hydraulic/hydrostatic system oil temperature.

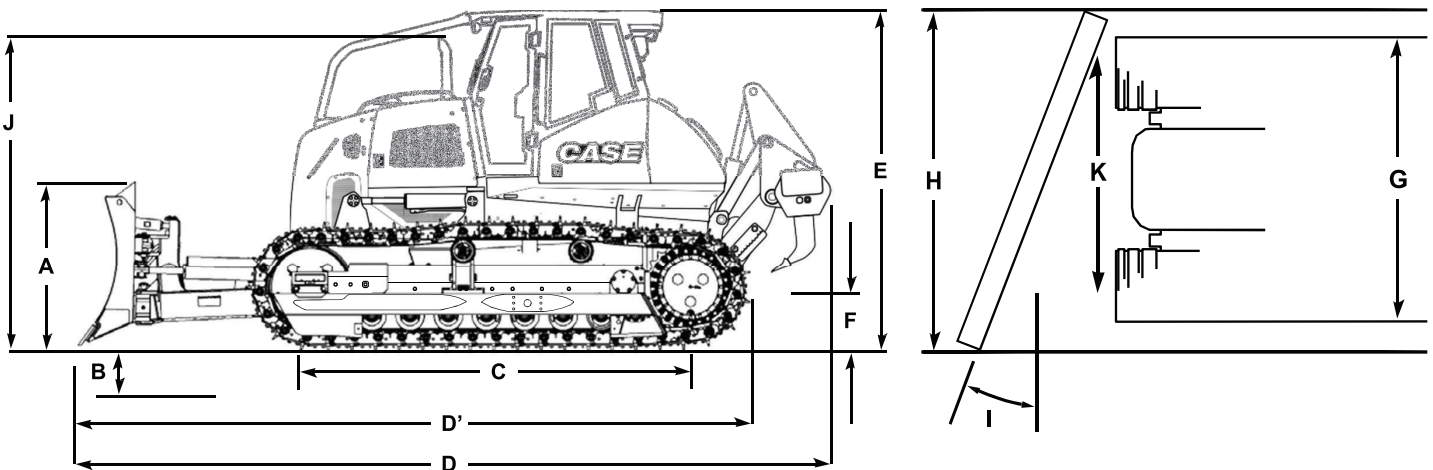

GENERAL DIMENSIONS		1150L	
A	Blade height	mm	1120
B	Depth of the blade in the ground	mm	483
C	Length of the track on the ground	mm	2590
D	Length of the blade in the straight position and ripper	mm	5973
D'	With blade in the straight position and drawbar	mm	5025
E	Height to top of cab	mm	2882
F	Ground clearance	mm	379
G	Width to the ends of the tracks	mm	2286
H	Width of the blade at a maximum angle	mm	2819
	Width of the blade fully placed on the ground	mm	3050
I	Blade angle of attack	°	25
J	Height of the exhaust	mm	2849
K	Track Gauge	mm	1712
	Width of the shoe	mm	508
	Area of the track on the ground	cm ²	26323
	Pressure on the ground	kgf/cm ²	0.47
	SAE blade capacity	m ³	2.9
	Elevation of the blade over the ground	mm	965
	Blade oscillation (up to 8.3°)	mm	439

NOTE: Ground clearance and overall height dimensions are with the grousers fully penetrated. Add 52.5 mm if unit is on solid surface.

L-SERIES 1650L

CRAWLER DOZERS

ENGINE

Model	FPT Industrial Engine F4HE9684U		
Cylinders	6		
Displacement	6.7 L		
Fuel injection	Direct common rail		
Fuel filter	Screw-on, with screen		
Cooling	Liquid		
Engine speeds	RPM		
High idle - no load	2200 +/- 50		
Rated - full load	2200		
Low idle	800+/- 25		
Horsepower @2200 rpm SAEJ1349			
Net		107 kW	
	Imperial	143 hp	
	Metric	146 hp	
Gross		116 kW	
	Imperial	155 hp	
	Metric	158 hp	
Max torque	690 Nm @ 1400rpm		

Engine lubrication

"Forced lubrication" with oil jet piston refrigeration system

Pump operating angle ratings

Side-to-side	45°
Fore and aft	45°

Radiator

Core size area	0.61 m ²
Rows of tubes	4

Fan

Diameter	660 mm
Propeller	Belt mechanical drive

TRANSMISSION COOLING

Type	Heat exchange
Core size	0.54 m ²

ELECTRICAL SYSTEM

Alternator	65 amps
Battery	2X12 V in series, maintenance free, 750 A CCA at -18°

POWERTRAIN

Dual path hydrostatic

Pump	Variable axial piston
Motor	Variable bent axis piston
Max. drawbar pull	275 kN
Transmission	Single lever control electronic tracking
Oil filter	4 micron, spin-on, replaceable

Travel speeds

Forward	0-9.7 km/h
Reverse	0-9.7 km/h

SAHR parking brake

(Spring applied hydraulically released)

Steering brakes	Hydrostatic
Oil Final drive	2 helical gear reductions to planetary reduction

Reduction ratio	61.4:1
-----------------	--------

HYDRAULICS

Pump Flow@2200 RPM	132 L/min
Max Pressure	207 bar
Lift cylinder PAT	nr.2

Bore diameter	88.9 mm
Rod diameter	50.8 mm
Stroke	826 mm
Angle cylinder PAT	nr.2
Bore diameter	101.6 mm
Rod diameter	50.8 mm
Stroke	508 mm
Tilt cylinder PAT	nr.1
Bore diameter	127 mm
Rod diameter	63.5 mm
Stroke	135 mm

BLADE

Variable blade pitch - adjustable	55° to 60°
Lift speed - per second	483 mm
Cutting edge	Reversible, replaceable
Width	200 mm
Length	2352 mm
Thickness	20 mm

UNDERCARRIAGE

Track adjustment	Grease injection
Hydraulic frame	Two-tier chassis, manufactured in structural steel
Track link pitch	190 mm
Track shoe height	56 mm
Pin diameter	38.5 mm
Bushing diameter	65 mm
Track shoes per side	45
Track rollers per side	8
Carrier rollers per side	2
Track roller rail diameter	203 mm

TRACK ON GROUND

Shoe width	559 mm
Tracks on ground	34093 cm ²

RIPPER

Max. penetration	478 mm
Width	1712 mm
Cut width	1636 mm
Max. ground clearance	424 mm
Max. number of shanks	3
Tooth spacing w/3 teeth	785 mm
Hydraulic cylinder	Double-acting
Diameter	102 mm
Stroke	254 mm
Rod	51 mm

SERVICE CAPACITY

Fuel tank	300 L
Engine oil w/filter	16.4 L
Engine oil w/o filter	15.6 L
Engine cooling system	32 L
Hydraulic reservoir	98.4 L
Final drive - per side	14.2 L
Track rollers - each	0.275 L
Front idlers - each	0.225 L
Carrier rollers - each	0.334 L

SPECIFICATIONS

OPERATING WEIGHT

Unit equipped with a compartment, full fuel tank, 77 kg operator, frontal traction hook, track protection, PAT blade, rear drawbar pull.

	1650L
Extra Long Tracks (XLT)	17960 Kg
ADD-ON WEIGHTS	
Drawbar	66 Kg
Ripper	1600 Kg
Roller protection	242.2 Kg

OPERATOR ENVIRONMENT

Cab ROPS/FOPS compartment with air-conditioning - single joystick for speed and direction - adjustable seat upholstered with cloth and air suspension - 50.8mm (2") retractable seatbelt - adjustable arm rests - two foot rests - rear view mirror - three windshield wipers - a dome light - 12 V connector for accessories - Padded roof - floor mats.

Warning lights - Air filter - alternators - failure diagnosis indicator - engine cooling fluid temperature - engine oil pressure - hydraulic filter - low fuel - emergency brake on - maintenance service indicator - transmission filter - transmission load pressure.

Indicators - Battery voltage - fuel level - digital hour meter/tachometer /diagnosis/service reminder - transmission oil temperature-transmission speed indicator - cooling fluid temperature

Audible alarms - Engine cooling fluid temperature - engine oil pressure - low fuel - hydraulic/hydrostatic system oil temperature.

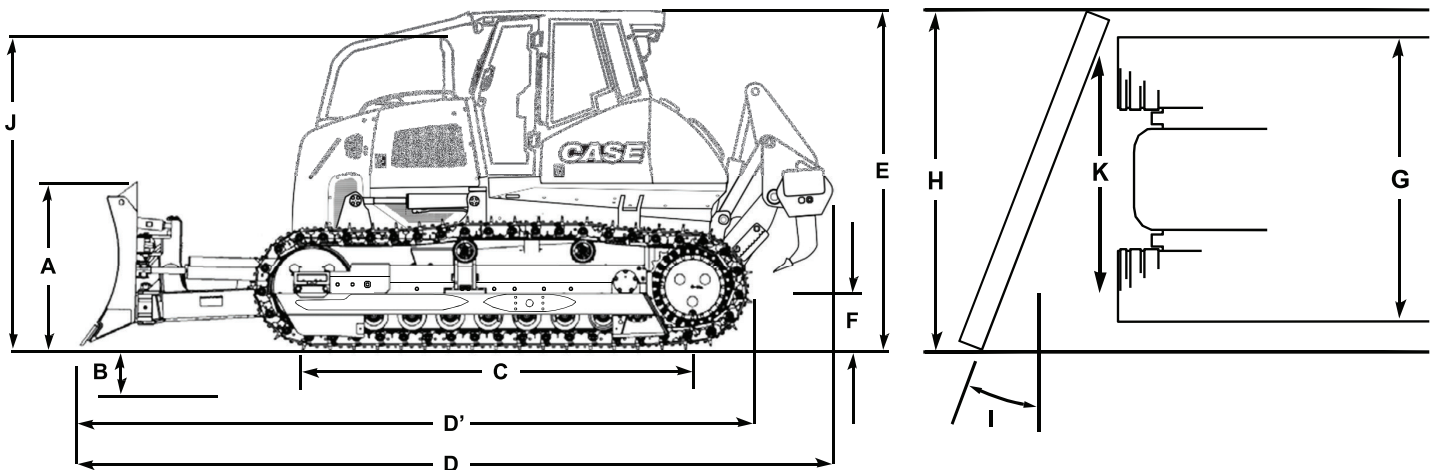

GENERAL DIMENSIONS		1650L	
A	Blade height	mm	1183
B	Depth of the blade in the ground	mm	490
C	Length of the track on the ground	mm	3050
D	Length of the blade in the straight position and ripper	mm	6801
D'	With blade in the straight position and drawbar	mm	5482
E	Height of cab with air conditioner	mm	3285
F	Ground clearance	mm	347
G	Width to the ends of the tracks	mm	2439
H	Width of the blade at a maximum angle	mm	2810
	Width of the blade fully placed on the ground	mm	3200
I	Blade angle of attack	°	25.7
J	Height of the exhaust	mm	2891
K	Track Gauge	mm	1880
	Width of the shoe	mm	559
	Area of the track on the ground	cm ²	34093
	Pressure on the ground	kgf/cm ²	0.47
	SAE blade capacity	m ³	3.5
	Elevation of the blade over the ground	mm	950
	Blade oscillation (up to 8.3°)	mm	450

NOTE: Ground clearance and overall height dimensions are with the grousers fully penetrated. Add 52.5 mm if unit is on solid surface.



STANDARD AND OPTIONAL EQUIPMENT

STANDARD EQUIPMENT

ENGINE

FPT Industrial engine NEF Family
Fan belt automatic tensioner
Engine oil cooler
Fuel filter
Dual element radial seat air cleaner
Turbine type pre-filter
65 A alternator
Battery (2) 12V 750 A CCA
Cooling system with radiators protected against possible sand projection
Excellent access for maintenance by panels on the sides of the engine

POWERTRAIN

2-way closed circuit with automatic speed variation with hydrostatic drive and electric control that adjusts the power and speed independently for each tread while turning or counter-rotating.

FINAL COMMANDS

Triple reduction of final commands
SAHR type parking brake (applied by spring and released by hydraulic pressure)

UNDERCARRIAGE

Hydraulic adjustment of the tracks through grease injection CASE Lubricated Track (CLT)
Sealed and Lubricated pins, upper and lower rollers sealed and lubricated
Front and rear track guides

BLADE

With manual inclination adjustment from 550 to 600
Blade control with a single lever (electric-hydraulic) on the right side of the operator, with in infinitely variable positions to control the six blade function (up, down, angled to the left and right, tilt to the left and right)

OPERATOR ENVIRONMENT

Cab ROPS/FOPS with A/C
Single joystick for speed and direction
Adjustable seat
Adjustable arm rests
50.8 mm (2") retractable seatbelt

OTHER

Anti-vandalism package
Reverse gear warning
Horn
Lights: 2 in front and 1 in rear
Master key
Mirror
Frontal tow hook
Frontal transmission protection

OPTIONAL EQUIPMENT

REAR MOUNTED EQUIPMENT

Rear draw bar
Ripper with 3 shanks

GUARDS

CAB canopy brush guard

OTHER

Drains that protect the environment while changing fluids
Intake air heater for ignition in cold climates

OPERATOR ENVIRONMENT

Rear windshield wiper
Additional work lights totaling four in the front and two in the back
rearview mirrors



BUILDING A STRONG CASE.

Since 1842, at CASE Construction Equipment we have lived by an unwavering commitment to build practical, intuitive solutions that deliver both efficiency and productivity.

We continually strive to make it easier for our customers to implement emerging technologies and new compliance mandates.

Today, our global scale combined with our local expertise enables us to keep customers' real-world challenges at the center of our product development.

The vast CASE dealers' network is always ready to support and protect your investment and exceed your expectations, while also providing you with the ultimate ownership experience.

Our goal is to build both stronger machines—and stronger communities. At the end of the day, we do what's right for our customers and our communities so that they can count on CASE.

CaseCE.com

NOTE: Standard and optional fittings can vary according to the demands and specific regulations of each country. The illustrations may include optional rather than standard fittings - consult your Case dealer. Furthermore, CNH Industrial reserves the right to modify machine specifications without incurring any obligation relating to such changes.

Conforms to directive 2006/42/EC

