

Why choose Genuine CASE IH oil filters?

ESSENTIAL PROPERTIES OF THE FILTER. A GENUINE CASE IH OIL FILTER OFFERS TWO KEY ADVANTAGES:

HIGH-QUALITY FILTRATION

CASE IH Genuine filters have a high-tech internal structure:

The multilayer medium. Made from three layers of synthetic material, it offers a higher filtration capacity and resistance.

MULTILAYER MEDIUM

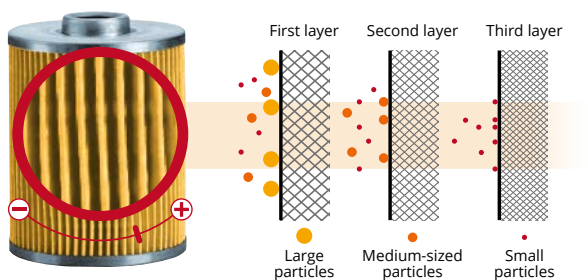

5X MORE EFFICIENT:

Genuine CASE IH oil filters have a retention efficiency percentage which is 5 times higher than standard filters.



OPTIMAL, LONG-LASTING LUBRICATION

For optimal, long-lasting lubrication with no premature wear to mechanical parts, the oil must be pure.

EXAMPLE OF OIL FLOWING THROUGH A CIRCUIT

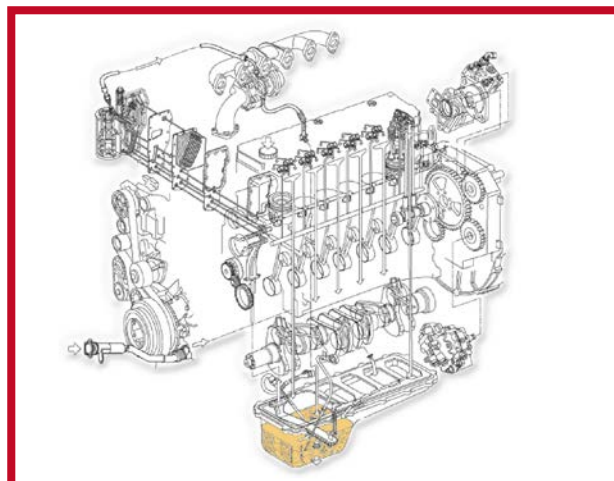

The retention efficiency and optimal flow rate of the oil also guarantee **IMPROVED COLD STARTING WHATEVER THE OUTSIDE TEMPERATURE.**

Outdoor temperature (in °C)

+30°

+15°

-10°



Oil flow rate capacity via oil filter (in %)

100%

100%

75%