

AUSTOFT 9000 SERIES SUGARCANE HARVESTERS



CASE IH



HIGHER PRODUCTIVITY

- New FPT Cursor 11 engine 420 hp
- New optimized hydraulic system
- +5% harvesting capacity

+5% HARVESTING CAPACITY



LOWER OPERATION COST

- Working with 1600 rpm engine
- Intelligent piston pumps

-10% FUEL CONSUMPTION **+50%** ENGINE LIFE



EASIER MAINTENANCE

- Easier access on maintenance components
- New modular bolted chassis

+30,000 HOURS OF FIELD AND BENCH TESTING

POWERTRAIN

- Lower fuel consumption
- Longer engine life
- Increased engine power

COOLING SYSTEM

- Improved reliability
- Better cooling performance
- Easier service

AUSTOFT 9000

THE LEGACY OF A NAME REACHES STATE OF THE ART PERFORMANCE.

The Case IH Austoft 9000 series takes mechanized sugarcane harvesting to a new level. More powerful engine, intelligent hydraulic system and other innovations provide greater harvesting capacity at a lower operating cost.

These updates to the Case IH Austoft sugarcane harvesters are the result of a large investment in development and more than 30,000 hours of field and bench testing, further improving machine reliability and delivering major reductions in Total Cost of Ownership.

OPERATION CAB

- Best in class in visibility
- Improved ergonomics
- Intuitive layout of commands

FRONT CHASSIS

- Stronger – longer service life
- Easier serviceability
- Better stability (front suspension cylinder)





AFS CONNECT

- Real time connectivity
- Integrated data to the management system
- Remote management of performance

HARVESTING SYSTEM

- Feed rate control – feeding automation
- Higher harvesting capacity
- Better efficiency

ELEVATOR

- Lighter
- Higher transport capacity
- Better serviceability

REAR CHASSIS

- Stronger – longer service life
- Non-structural bolted hydraulic tanks



NEW ENGINE

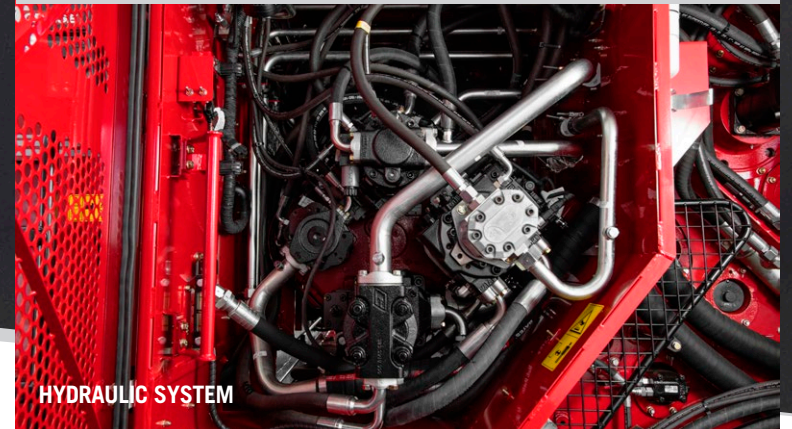

HYDRAULIC SYSTEM

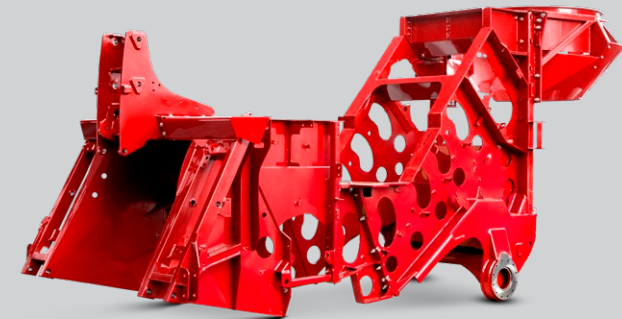

NEW BOLTED MODULAR CHASSIS

AUSTOFT 9000 SERIES MODEL OFFERING

Case IH offers two models for the Austoft series capable of meeting the specific needs of various row spacings and agronomic requirements:

- Austoft 9900 (tracks)
- Austoft 9000 (wheels)

All models in the Austoft family were developed with a focus on customer needs, on the quality of harvesting and, above all, on the profitability of your business.

AUSTOFT 9000

- On wheels





AUSTOFT 9900

- On tracks

BETTER PRODUCTIVITY IN THE FIELD

The Austoft 9000 series offers several technologies to increase efficiency in the field. Among them is the renowned Advanced Farming Systems (AFS), which included autoguidance and a new telematics system that allows 4G connectivity on the machine. These innovations provide more information and data, generating high precision and agility in decision-making and maximizing the productivity of your operation in all stages of the production cycle.



AFS 372 receiver

AFS AUTOGUIDANCE:

Automatic guidance makes operation of your Austoft sugarcane harvester even easier and more efficient. Prevent the harvester from travelling over rows and ratoons, preserving growth potential. It also reduces operator fatigue, saves fuel, and allows you to take advantage of all of the harvester's productivity-enhancing features.

BENEFITS

- Reduced losses
- Higher productivity
- Lower fuel consumption
- Traffic control
- Reduced fatigue
- Easier operation



The Austoft 9000 sugarcane harvesters are the first to be shipped from the factory with the new AFS Connect 4G telematics system with the first 3 years of subscription included in the package (data transfer signal subscription via cell phone) as standard. The system allows you to connect the harvester to the AFS Connect telematic portal, a platform for the integrated management of your business. The portal brings tools for Fleet Monitoring, Agronomic Management and Data Management, and was designed to help decision making in real time, in a simple and intuitive environment. Data can even be transferred directly to your management, business intelligence (BI) or enterprise resource management (ERM) system.

MORE POWER, STRENGTH AND DURABILITY IN ALL COMPONENTS.

- Equipped with the FPT Cursor 11 engine with 420hp (310kW), replacing the Cursor 9 (358hp/260kW of power)
- Cursor 11 working rpm is 1600 rpm: lower fuel consumption and increase in hours in engine life

ENGINE	6 cyl. in line
INJECTION SYSTEM [bar]	COMMON RAIL (up to 2200 bar)
TURBOCHARGER	eVGT / WG
VALVES PER CYLINDER	4
ENGINE DISPLACEMENT	11.1 L
BORE x STROKE (mm)	128 x 144
Max POWER [hp]	420 @ 1600 rpm
Max TORQUE [Nm]	2300 @ 950 rpm
WEIGHT [Kg]	1.260
DIMENSIONS [mm] - C / W / H	1286 / 1035 / 704

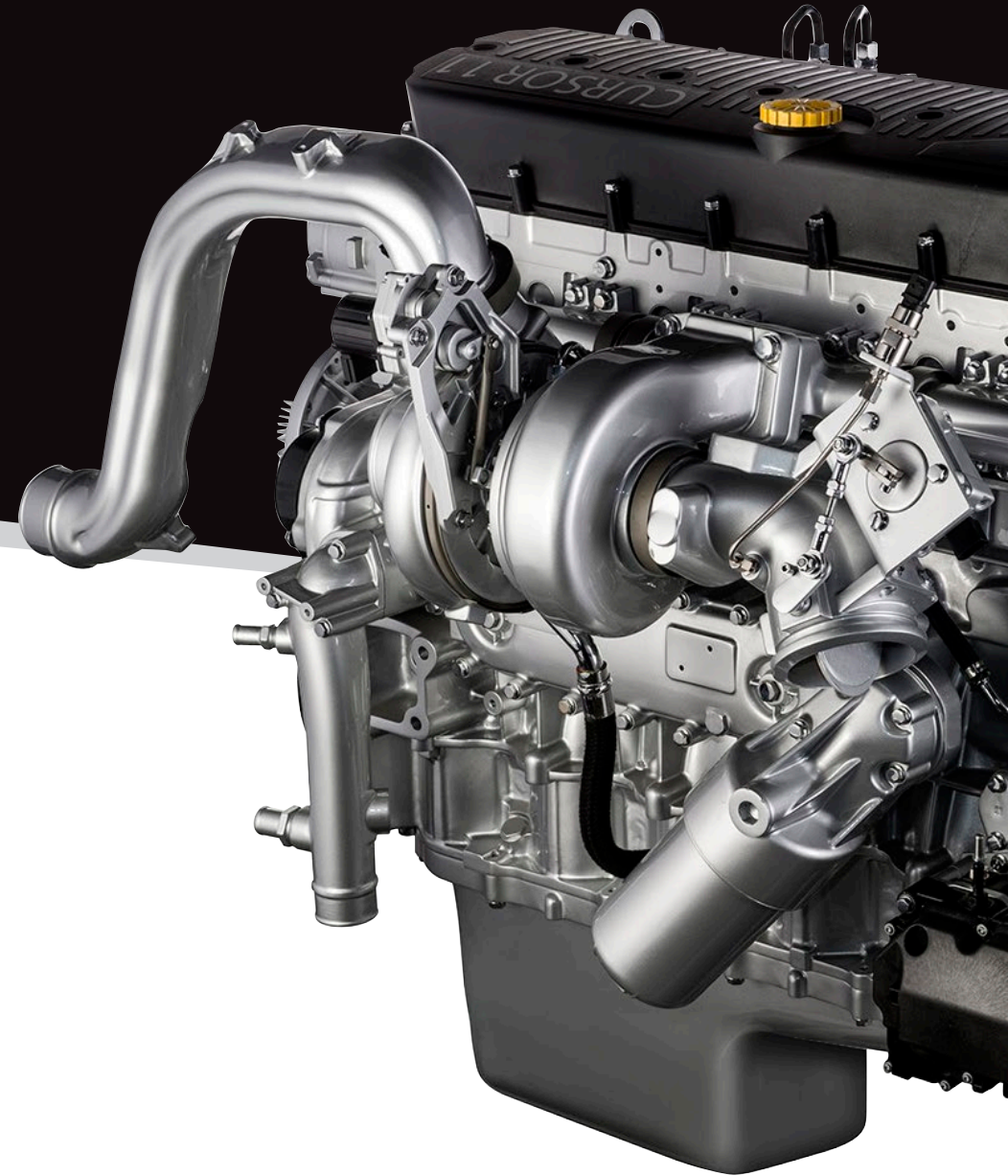

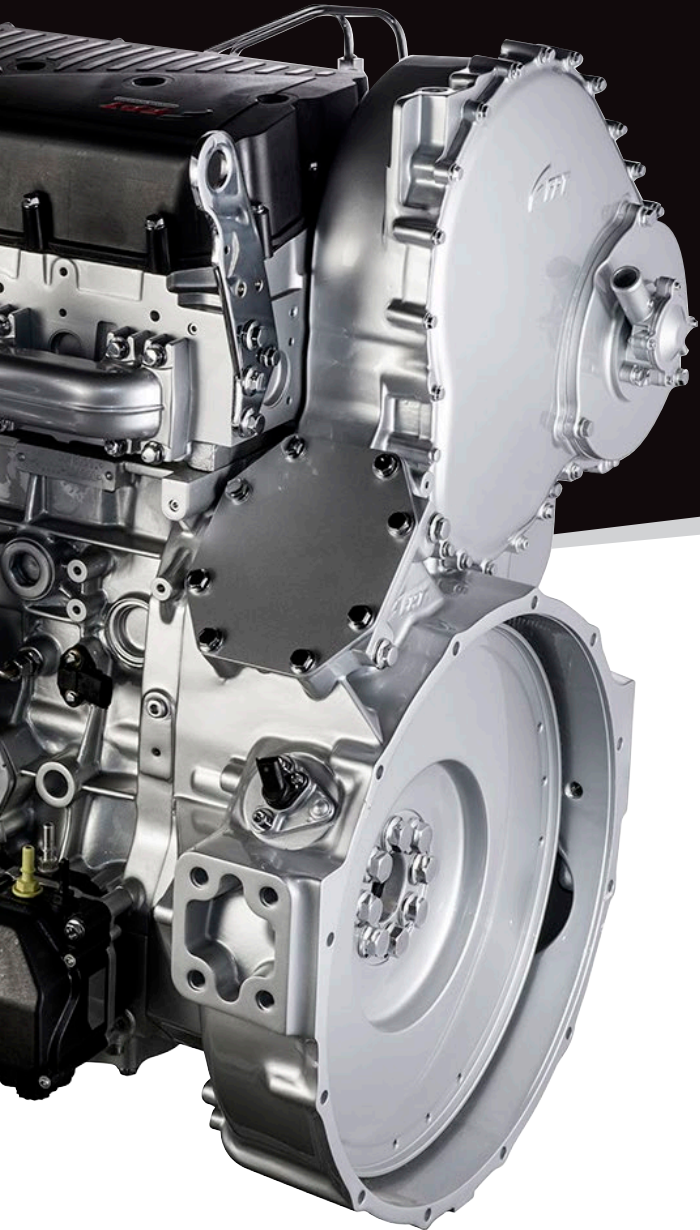

+ POWER for increased harvesting capacity



Always attentive to the needs of each application, FPT offers simplified technology for those who need practicality, and state-of-the-art electronic technology in applications that require greater robustness.

This Cursor 11 engine ensures greater performance and fuel economy, as there is a better mixture of air with the fuel (atomization), due to the movement of the fuel mist inside the combustion chamber. Common Rail electronic fuel injection technology guarantees the right amount of fuel at the right moment, hence having an almost instantaneous maximum power delivery, when requested by the operation.

Cursor engines also have an inverted ignition order, so the engine vibrates less, generating the lowest noise and fuel consumption in the market.

FPT Industrial focuses a lot on the efficiency of its engines. This focus results in superior power density, meaning the FPT engine delivers more with an engine that is a little smaller compared to common engines on the market, and depending on the application: more efficient fuel consumption.

HYDRAULIC SYSTEM

The hydraulic system features intelligent piston pumps with individual electronic controllers that allow exact adjustment of the flow required for each function, without wasting power. The closed circuit of the traction system, in addition to the new pumps, also has an electronic fault system which acts in an emergency situation, further increasing the safety of the operation. Another new closed circuit is the chopper system, which allows working at higher pressures and smaller hydraulic engines, contributing to cost reduction and increased hydraulic efficiency.

The piston pumps used in the primary extractor and cooling fan deliver greater energy efficiency, cleaning the trash even better than on previous models (Case IH Austoft sugarcane harvesters were already best-in-class), while the SmartFan lowers cooling power consumption.

Due to the better efficiency there is less heat generation, allowing the system to work with lower temperatures in the hydraulic oil, increasing the useful life of the components and reducing fuel consumption.

Another major evolution of the new hydraulic system of the Austoft 9000 series sugarcane harvesters is the high abrasion resistant hoses, arranged in an optimized routing, reducing the number of failures during the harvest, contributing to the reduction of downtime and hydraulic oil consumption.

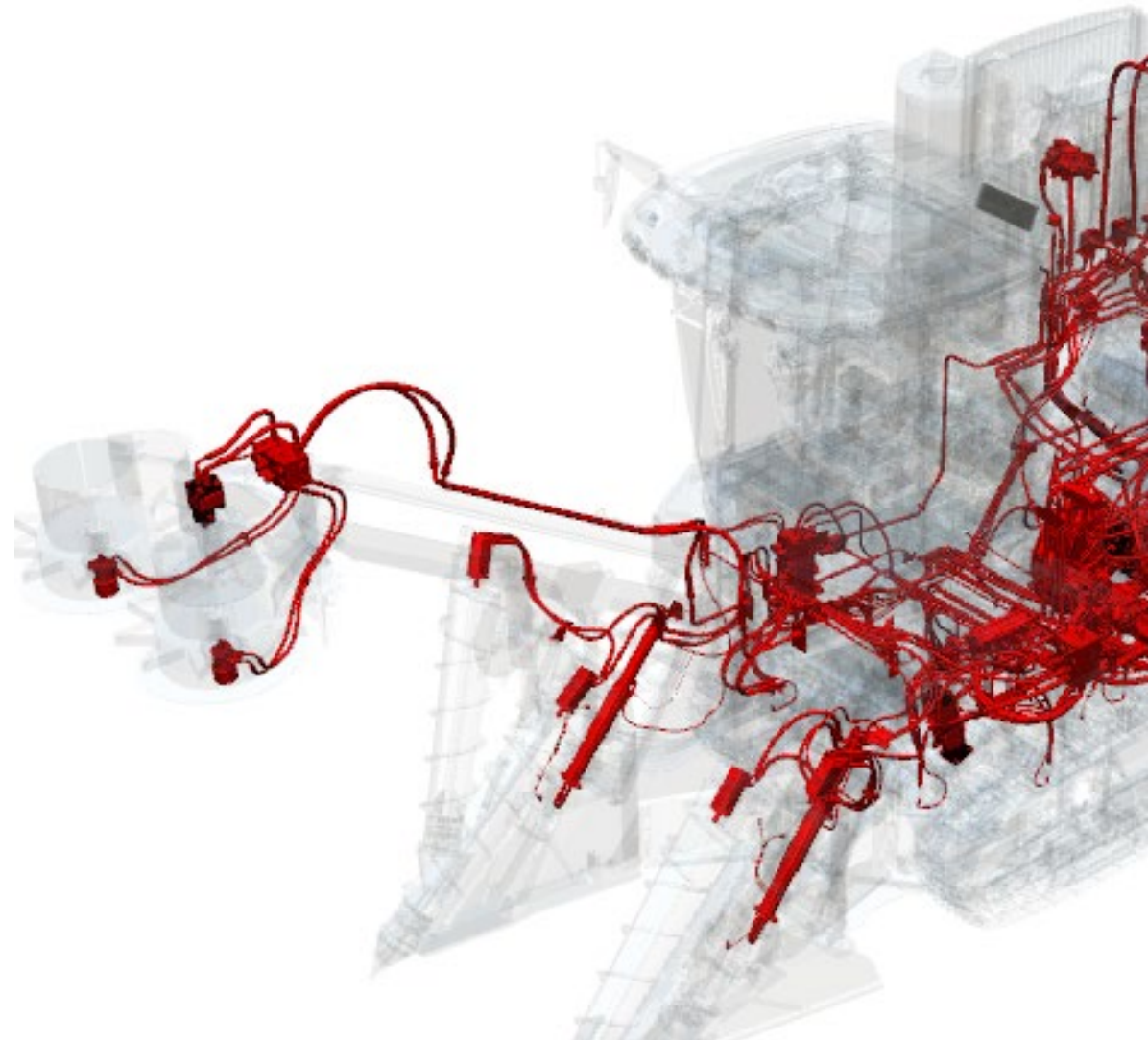

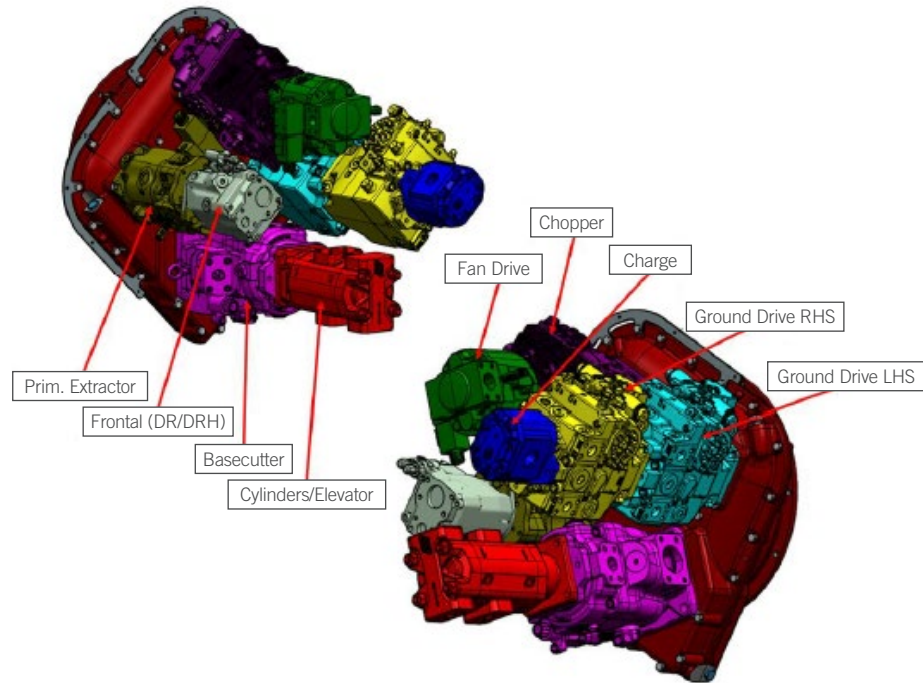
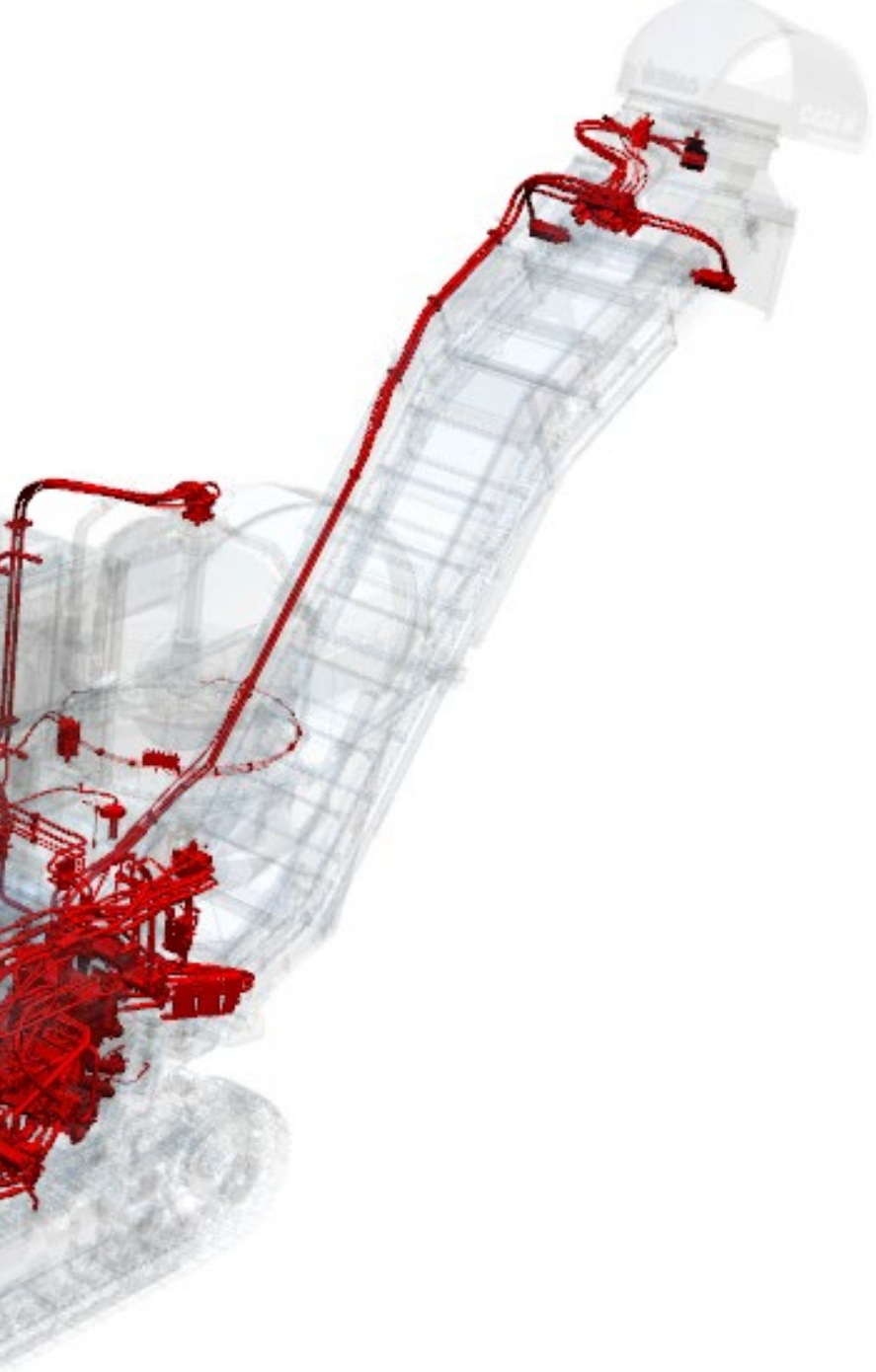

- New hydraulic system with dedicated piston pumps: more efficient use of engine power
- Gear pumps: only on circuits with low fuel consumption demand

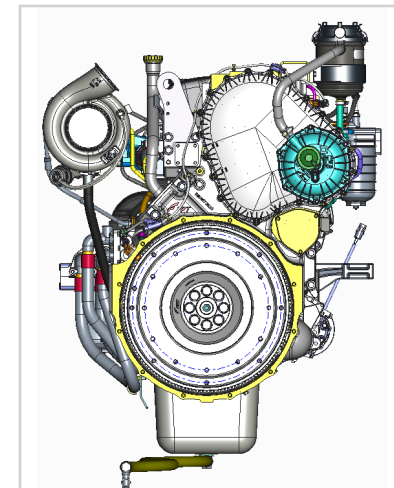
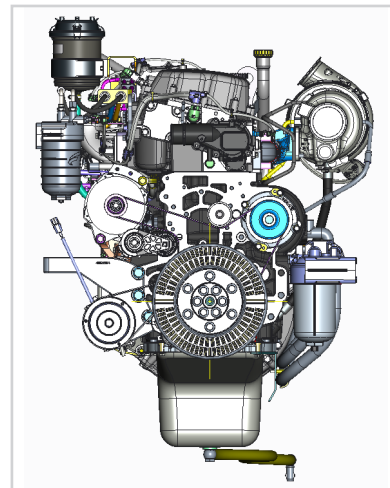

**DESIGNED TO
WITHSTAND IMPACTS
AND LONG HARVEST
SEASONS.**



+ SERVICEABILITY
Front and rear chassis



The Austoft 9000 series chassis is composed of modular sections joined by screws forming the main chassis:

The main structures of the harvester are also now bolted to the main chassis:

- Upper and lower hydraulic tank
- Primary extractor structure
- Topper support

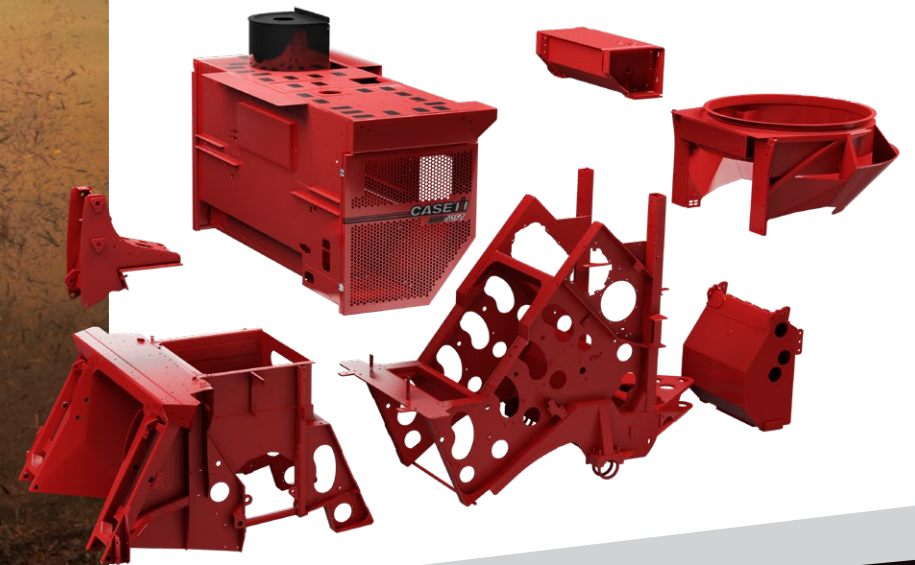

 **+ FLEXIBILITY**

 **+ ROBUSTNESS**

SMART OPERATING CONTROLS

EFFICIENCY, PRECISION AND HIGH PERFORMANCE IN OPERATIONS.



Feed Rate Control

Variable hydraulic flow combines with automatic controls that adjust harvesting functions based on operating conditions. It optimizes fuel consumption, prevents 'choking' and automatically acts on two levels:

LEVEL 1

- Increases RPM of harvest functions based on base cutter and chopper rollers pressures.

LEVEL 2

- If increasing the RPM of the harvesting functions is not sufficient to reduce base cutter and chopper pressures, the ground speed is automatically reduced.

When base cutter and chopper roller pressures return to normal levels, ground speed automatically increases to the previous setting on cruise control.



+ NEW SYSTEM AUTO HARVEST DISENGAGE

If activated for more than 60 seconds without chopper pressure, harvesting functions are automatically disabled or reduced.



+ LOWER FUEL CONSUMPTION

And lower wearing of moving parts

RESISTANCE AND DURABILITY FOR THE WHOLE MACHINE

New crop divider
and side trim arms
in casting iron

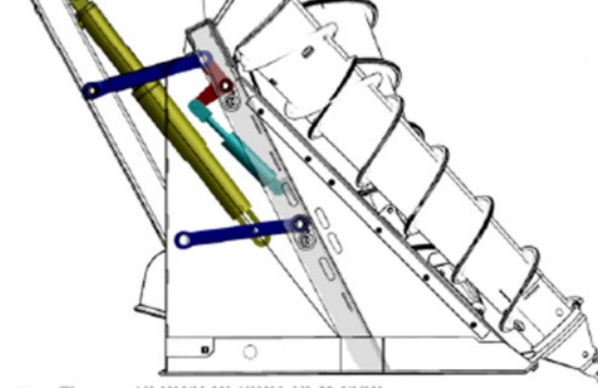

**+ DURABILITY OF
THE COMPONENTS**



**+ HARVESTER
UPTIME**



New suspension cylinder repositioned closer to the front of the harvester makes the AutoTracker system more efficient while reducing the response time for suspension lift command, improving the machine front grip.

TOTAL MACHINE PROTECTION, COMFORT AND SAFETY FOR THE OPERATOR.

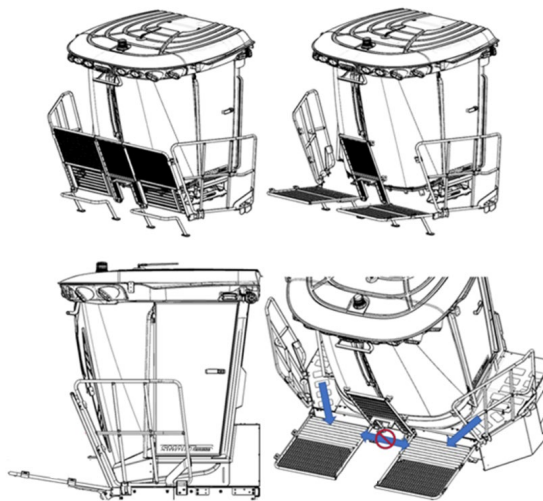

NEW WINDSHIELD PROTECTION

It is foldable and transforms into a platform that allows access to the front of the cabin for cleaning and maintenance.



+ COMFORT



+ SAFETY

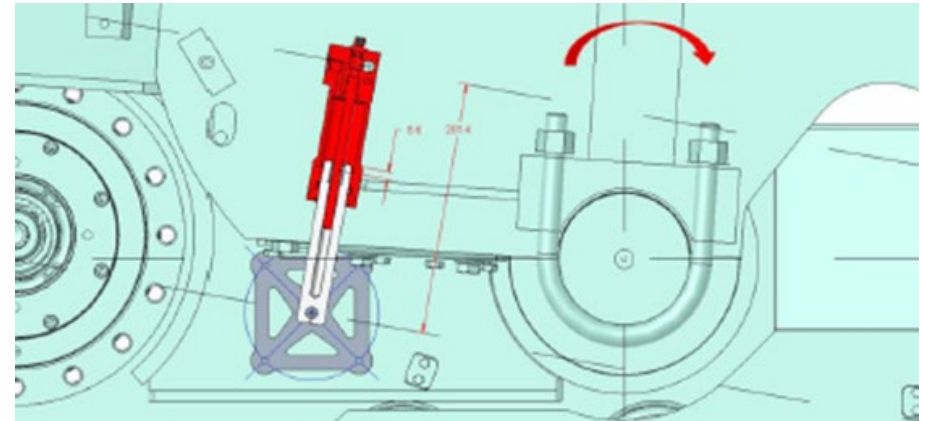

NEW AUTO TRACKER

Controls the height of the base cutter, based on a reference pressure and the position of the suspension cylinder. The nitrogen cylinder was replaced by a position cylinder at the rear of the machine, reducing maintenance costs.



NEW "EXIT LIGHTS" SYSTEM

By placing the key in the "off" position, the lights remain turned "on" for 90 seconds, allowing the operator to exit the cab with more safety.



BETTER OPERATING ENVIRONMENT AND INCREASED PRODUCTIVITY

More intuitive symbols and commands on the right-side console and multifunction handle.

HIGHLIGHT FEATURES

RESISTANCE AND DURABILITY FOR THE WHOLE MACHINE

NEW BATTERY COMPARTMENT

The battery compartment is now positioned close to the engine box and with easier access through the side platform. This makes battery replacement even easier, reducing machine downtime.

Complete 12V system provides easier serviceability

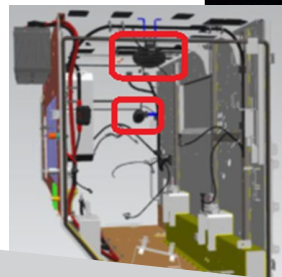
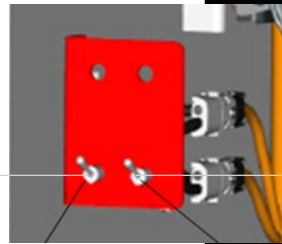

LIGHT SWITCH

- Engine Box

SERVICE LIGHT SWITCH – TOPPER

- Base Cutter



+ NEW SERVICE LIGHTS

- The engine box now has two internal lights for maintenance in dark conditions.
- The engine service lights and the topper/base cutter switches are now positioned on the engine box, making service even easier.

COOLING PACKAGE

New vertical radiators with a new access door.

Better serviceability and reliability of the entire system.

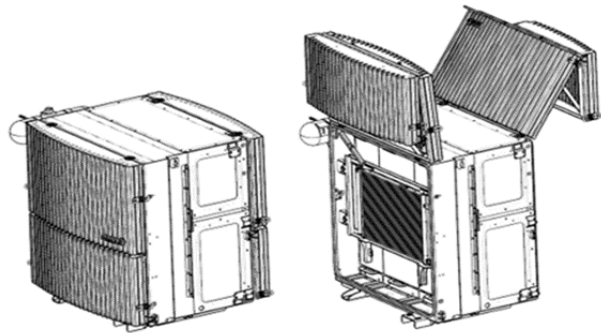

NEW AIR CIRCUIT

Its components maintain quality of air inside the engine.

45% savings on replacement air filters with the new system.

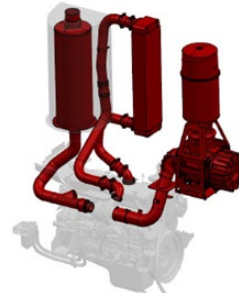

Pre-filter with top spin cleaning system

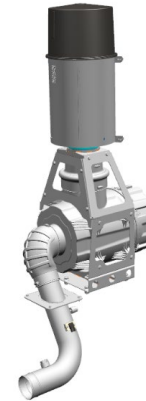

DIESEL EXHAUST FLUID CIRCUIT (DEF - Diesel Exhaust Fluid)

– Only Tier 3 and above

Components that supply DEF within the engine exhaust system include:

- Urea Tank (DEF): 70 liters
- Injection Controllers
- Filters Tube
- Urea Level Sensor
- Injector

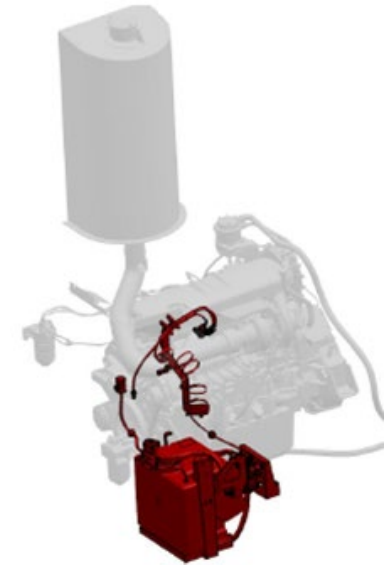

MAXIMUM PERFORMANCE, WITH LOWER OPERATIONAL COST.



HIGHER PRODUCTIVITY

New FPT Cursor 11 Engine 420hp & New Optimized Hydraulic System

10% HIGHER

HARVESTING CAPACITY
(TESTS INDICATE 15%)



LOWER OPERATIONAL COST

1600 engine working RPM and Intelligent Hydraulic Pumps

10% LOWER

FUEL CONSUMPTION
(TESTS INDICATE 18%)

**50%
LONGER**

ENGINE LIFE



EASIER MAINTENANCE

Simple access to maintenance components
New Bolted Modular Chassis

**+DE 30,000 HOURS OF FIELD
& BENCH TESTING**

DIMENSIONS

DATASHEET

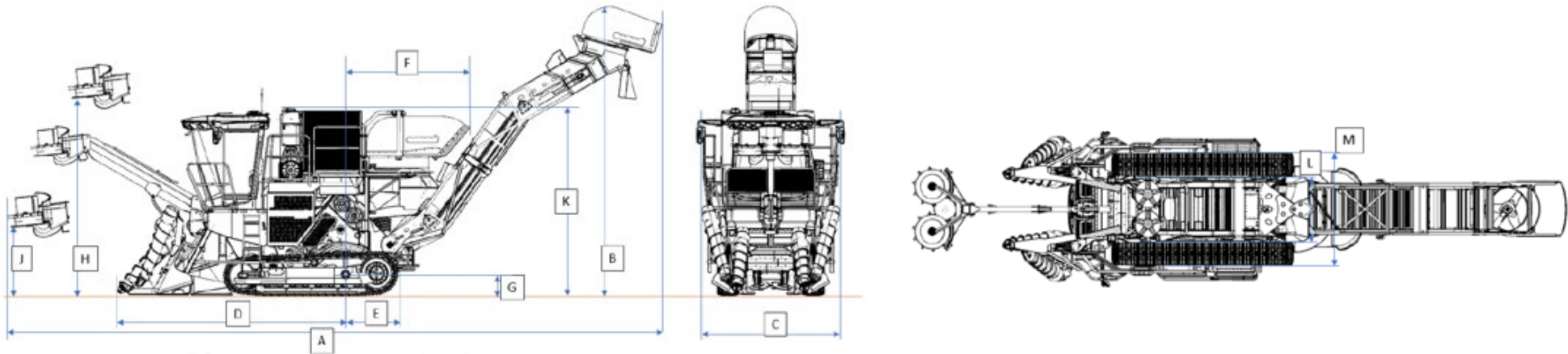

1. Elevator 900 mm
2. Standard topper
3. Dimension of Line Dividers
(Closed Mirrors) | To open + 230 mm
4. Axle width: standard
(1880mm) / track shoes 16"
5. Main chassis: standard

ITEM	DESCRIPTION	Austoft 9000	Austoft 9900
A	Total Length	13,340 mm	13,930 mm
B	Total Height	6,090 mm	6,340 mm
C	Total Width	3,040 mm	3,040 mm
D	Axle center to tip of crop divider	5,230 mm	5,100 mm
E	Axle center to rear limit if tracks	1,150 mm	1,150 mm
F	Axle center to rear limit of primary extractor hood	2,710 mm	2,710 mm
G	Axle center to the ground	720 mm	450 mm
H	Topper max height	3,890 mm	3,890 mm
J	Topper min height	890 mm	890 mm
K	Maximum Height (Non-Retractable)	4,240 mm 4,110 mm	4,240 mm 4,110 mm
L	Internal distance between tracks	1,780 mm	1,410 mm
M	External distance between tracks	2,550 mm	2,350 mm

SPECIFICATIONS

TECHNICAL CHART

AUSTOFT 9000/9900	
ENGINE	
Model:	FPT Cursor 11
Volume:	11.1 litres
Cylinders:	6 in line
Power:	420 cv (310 kW) @ 1600 rpm
Injection system:	Common Rail
Tier 0/ Tier 3 / Stage V	
Alternator	185A 12V
COOLING SYSTEM	
Type:	Fixed screen radiator package for air intake
Location:	Harvester upper part
Smart Fan:	Fan with variable speed control
OPERATOR CAB	
n° of doors:	2
Air conditioning and heater	
Operator's seat with air suspension	
Training seat	
Monitor AFS Pro 700	
Monitoring of all harvesting, maintenance and precision farming functions integrated into the AFS Pro 700 monitor	
Customizable screens with alerts of irregularities or failures by the monitor	
Emergency shutdown system in the absence of the operator	
Windshield wiper and washer	
Split rearview mirrors with impact protection	
Cabin and instrument panel lighting	
Steering and electronic transmission by joystick or steering wheel in tire model	
Multifunctional handle/ transmission lever / operation buttons next to the armrest	
Fuse panel for all circuits	

AUSTOFT 9000/9900	
REVERSE ALARM WITH SECURITY BEACON	
Beacon Lights (rotating safety beacon)	
8 cab mounted LED headlamps	
Tilting cabin with pre arrangement for radio and autopilot	
Optional: Case IH AFS autoguide autopilot	
TRANSMISSION	
Type: Hydrostatic with variable speed forward and reverse	
Ground speed (wheeled version) : 0 @ 20 km/h	
Ground speed (track version) : 0 @ 11.7 km/h	
CHOPPER	
Blades per roller: 4	
Drums diameter: 380 mm	
Throwing rubbers: standard	
Adjustable deflector plates	
Reversible hydraulic drive	
Blade width: 65mm (replaceable)	
Billet length adjusted by cabin	
Optional: 3-knives roll	
TRACKS	
Type of chain: greased	
Bent track shoes with agricultural design	
Track width: 406mm (16")	
Guides: Heavy Duty	
Options: Track with greased chain of 18"; Sealed and lubricated 18" ; 16" sealed and lubricated	
KNOCKDOWN ROLLER	
Hydraulic and reversible drive	
Feeding slats design	
Severe Conditions Kit: Available through parts	

AUSTOFT 9000/9900	
Knockdown roller width: 1080 mm	
FEED ROLLERS	
Number of rollers: 5 lower fixed and 5 upper floating	
Hydraulic and reversible drive	
Floating rollers with rubber stoppers	
Rolls width: 900mm	
BUTTLIFTER ROLLER	
Hydraulic and reversible drive	
Hollow paddle (standard); closed flaps optional	
3 paddle (standard); 4 paddle (optional)	
Width: 900mm	
CAPACITY	
Fuel: 620 litres	
Hydraulic oil: 500 litres	
OTHER ITEMS	
3 operational cameras	
WEIGHT	
Austoft 9000: 17,360kg	
Austoft 9900: 20,750 kg	







caseih.com

CNH Industrial Asia Pacific

Safety never hurts! Always read the Operator's Manual before working with any equipment. Inspect equipment before using it, and be sure it is operating properly. Follow the product safety signs, and use any safety features provided. This literature has been published for worldwide circulation. The standard and optional equipment and the availability of individual models may vary from one country to the next. Case IH reserves the right to undertake modifications without prior notice to the design and technical equipment at all times without this resulting in any obligation whatsoever to make such modifications to units already sold. Whilst every effort is made to ensure that the specifications, descriptions and illustrations in this brochure are correct at the time of going to press, these are also subject to change without prior notice. Illustrations may show optional equipment or may not show all standard equipment. Case IH recommends genuine lubricants. CASE IH Austoft 9000 series brochure – 04/2022

22APACCOMAUS001

CASE IH