

# E15X

ELECTRIC MINI EXCAVATOR



# E15X ELECTRIC MINI EXCAVATOR SPECIFICATIONS

## OVERVIEW

Operating weight with Long Arm & Canopy	lb (kg)	3194 (1449)
Traveling speed	mph (km/h)	1a : 0 ÷ 1.1 / 2a : 0 ÷ 2.4 (1a : 0 ÷ 1.8 / 2a : 0 ÷ 3.8)
Slew speed	rpm	9.5

## ELECTRICAL SPECIFICATIONS

Engine		
Type	Internal Permanent Magnets (IPM)	
Max. power (2.800 rpm)	hp (kw)	21 (15.65)
Supply	Three-phase alternating current	
Operating modes:	max rpm	2.400 - ECO 2.600 - STD 2.800 - PWR
Supply		
Battery chemistry	lithium-ion	
Gross capacity	kWh	21.5
Nominal voltage of the system	voltage	102
Expected run time (dependent on application)	hour	4 ÷ 8
Charging times		
20-80%, Onboard 120V 1 phase	hour	8.5
20-80%, Offboard 480V 3 phase	hour	1
0-100%, Onboard 120V 1 phase	hour	14
0-100%, Onboard 480V 3 phase	hour	1.5

## HYDRAULIC SYSTEM

Control valve	Load Sensing Flow Sharing	
Hydraulic system capacity	gal (l)	4 (15)
Pump type	1 low-noise helical gear pump	
Pump displacement	in <sup>3</sup> (cc)	0.6 (10.1)
Pump flow rate	gal/min (l/min)	7.4 (28)
Max. circuit calibration pressure	psi (bar)	2611 (180)
Auxiliary system (max pressure):	gal/min (l/min)	7.4 (28)
AUX 1 single or double effect	psi (bar)	2600 (179.3)
AUX 2	gal/min (l/min)	2.64 (10)
	psi (bar)	2600 (179.3)

## PERFORMANCES

Max. digging depth		
Standard arm	ft (m)	6.7 (2.045)
Optional arm	ft (m)	7.1 (2.175)
Max. dumping height		
Standard arm	ft (m)	7.5 (2.290)
Optional arm	ft (m)	7.8 (2.380)
Bucket breaking force (standard arm) ISO 6015	lbf (daN)	2600 (1150)
Arm breaking force (standard arm) ISO 6015	lbf (daN)	1416 (630)
Traction force	lbf (daN)	2.25 (1.000)
Ground bearing pressure		
Canopy	psi (kg/cm <sup>2</sup> )	4.4 (0.31)
ABS roof	psi (kg/cm <sup>2</sup> )	4.6 (0.32)
Max. slope (60%)	degrees	30

## DIMENSIONS

Minimum Overall Width (tracks retracted)	in (mm)	31.1 (790)
Maximum Overall Width (tracks extended)	in (mm)	41.3 (1050)
Total height	ft (m)	7.5 (2.300)
Rear rotation radius	in (mm)	28 (710)
Digging arm length		
Standard arm	ft (m)	3.3 (1.020)
Optional arm	ft (m)	3.8 (1.150)
Tracks width	in (mm)	7 (180)
Rollers number (for each side)	3	

## CONTROLS

Boom, dipper stick, bucket and turret swing	2 electro-proportional joysticks
Track movements (included counter rotation)	2 electro-proportional levers
Dozer blade	Electro-proportional lever
Auxiliary system with latch AUX 1 (single or double effect)	Electro-proportional switch on right joystick
Boom swing	Electro-proportional switch on left joystick

## OPERATING WEIGHT

Standard Arm & Roll Bar	lb (kg)	3130 (1420)
Standard Arm & Canopy	lb (kg)	3186 (1445)
Long Arm & Roll Bar	lb (kg)	3139 (1424)
Long Arm & Canopy	lb (kg)	3194 (1449)
Mechanical quick coupler	lb (kg)	49 (22)

NOTE: Weight includes bucket, 165 lb operator, fluids, full fuel tank.

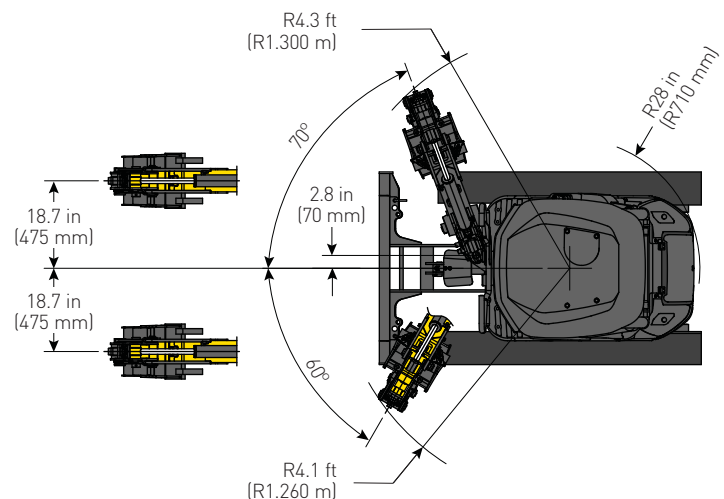
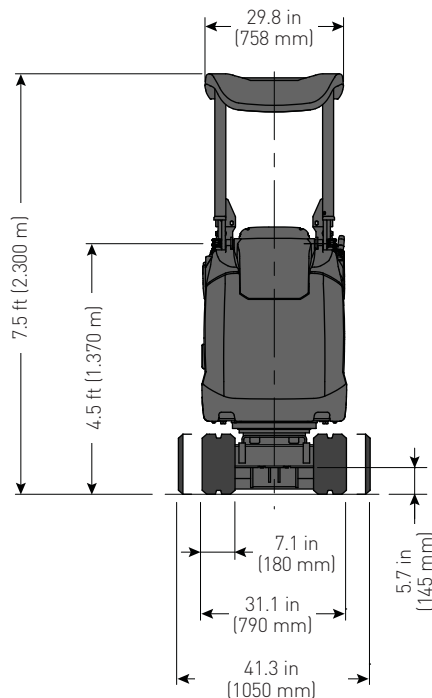

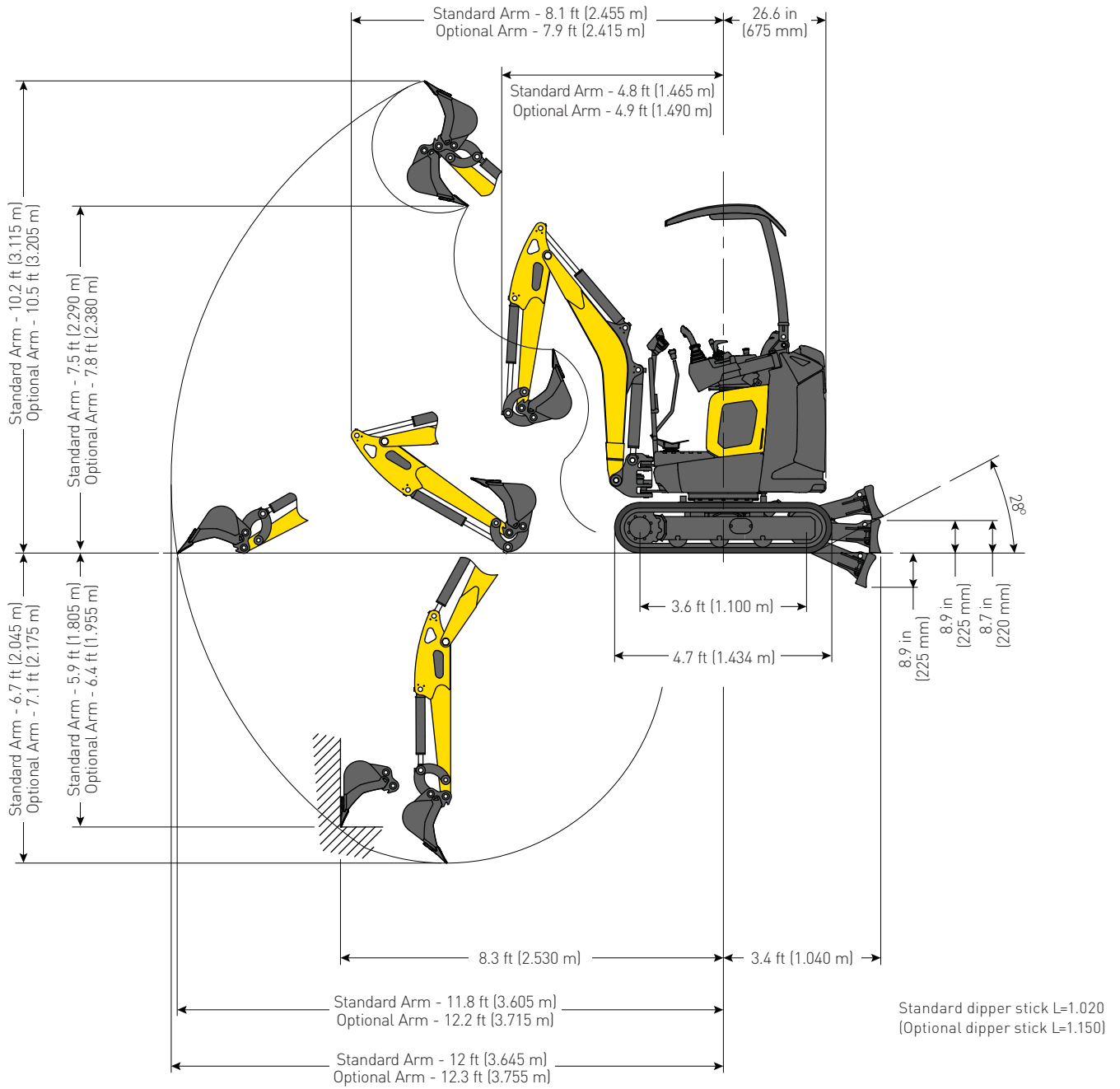

### LIFTING CAPACITY

Opening arm from the rotation's center ft (m)  
Lifting capacity lb (ton) at 1.0 m height

		2	3	MAX
Frontal and lowered dozer blade	lb (ton)	660 (*0.33)	480 (*0.24)	460 (*0.23)
Frontal and lifted dozer blade	lb (ton)	660 (*0.33)	380 (*0.19)	340 (*0.17)
Lateral, open undercarriage	lb (ton)	480 (0.24)	240 (0.12)	240 (0.12)

\*Indicates the hydraulic load limit.

The lifting capacity is based on the ISO 10567 and it does not exceed more than the 75% of static tipping load or more than the 87% of the hydraulic lifting capacity of the machine.

These pictures may include optional rather than standard settings. Technical features are not binding and may be modified without notice in any moment.

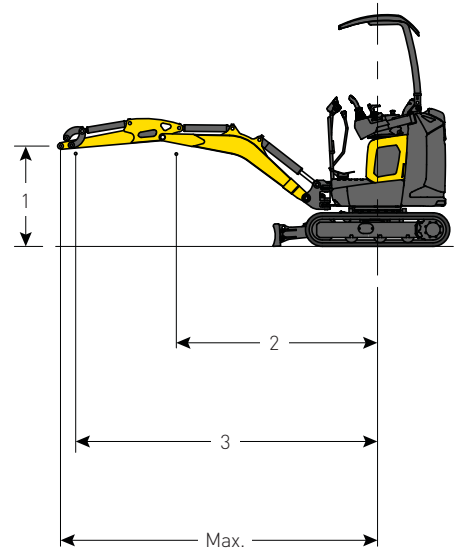

# World class products demand world class dealers.



The purchase of a New Holland machine is just the beginning of our relationship together. Consider your experienced New Holland Construction equipment dealer as your local partner in productivity. Assistance in selecting the right model for your operation and developing an affordable leasing or financing plan through New Holland's financing division, CNH Industrial Capital, are just a few advantages your local dealer can provide.

Your New Holland dealer's full-service capabilities bring you responsive support with genuine New Holland parts and all-makes

coverage. More importantly, we are there wherever and whenever you need us with our fully equipped service vehicles. From customized maintenance programs to professional operator and technical training, our factory-trained service and parts experts are there to assist you with any of your equipment support needs.

Your business deserves nothing less than world-class products, supported by a world-class business partner. That's your local New Holland Construction equipment dealer — your partner in productivity.



Learn more at [www.newholland.com](http://www.newholland.com)



New Holland Construction  
500 Diller Ave.  
New Holland, PA 17557

Design, materials and/or specifications are subject to change without notice and without liability therefor. Specifications are applicable to units sold in Canada, the United States, its territories and possessions, and may vary outside these areas.

© 2023 CNH Industrial America LLC. All rights reserved. New Holland is a trademark registered in the United States and many other countries, owned by or licensed to CNH Industrial N.V., its subsidiaries or affiliates. Any trademarks referred to herein, in association with goods and/or services of companies, other than owned by or licensed to CNH Industrial N.V., its subsidiaries or affiliates, are the property of those respective companies.



Safety begins with a thorough understanding of the equipment. Always make sure you and your operators read the Operator's Manual before using the equipment. Pay close attention to all safety and operating decals and never operate machinery without all shields, protective devices and structures in place.

NHC713023329 • 0423 • OTP • PRINTED IN U.S.A.