

Enhanced High Flow (EHF) auxiliary hydraulics

The Enhanced High Flow (EHF) auxiliary hydraulic feature provides **155 L/min (41 US gpm) at 283 bar (4100 psi)** to the auxiliary circuit. Follow the attachment's operator's manual on specific installation procedures, operation, and removal procedures.

NOTE: The Enhanced High Flow setting can only be used with approved attachments and is controlled by a circuit interlock installed at the multifunction plug with the attachment.

NOTE: All approved Enhanced High Flow (EHF) attachments will have an electrical connection. This prevents operating attachments that are not approved to handle **283 bar (4100 psi)** in EHF mode.

NOTICE: If the circuit interlock connection is not made with the attachment and the EHF mode switch is engaged, only standard High Flow will be available on the EHF couplers.

NOTICE: The proportional auxiliary thumbwheel must stay in the neutral position when not in use or required. Overheating of the hydraulic oil or poor attachment operation may occur.

Refer to "Implement Auxiliary Flow Control" under "Machine Settings" **3-57** for more details on auxiliary flow control activation.

- Electrical connection **(1)**.
- Male work port **(2)** – 3/4 inch coupler size
- Case drain port **(3)** – 3/8 inch coupler size
- Female work port **(4)** – 3/4 inch coupler size

Before operating the approved attachment, confirm the electrical connection **(1)** is secured in place.

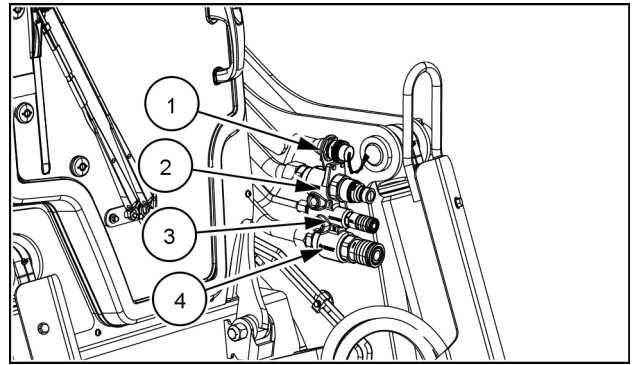

Press the EHF side of the auxiliary hydraulic switch **(5)** on the left-hand front console to activate Enhanced High Flow.

Press the EHF side of the auxiliary hydraulic switch **(5)** again to deactivate Enhanced High Flow. High flow hydraulics is the default setting.

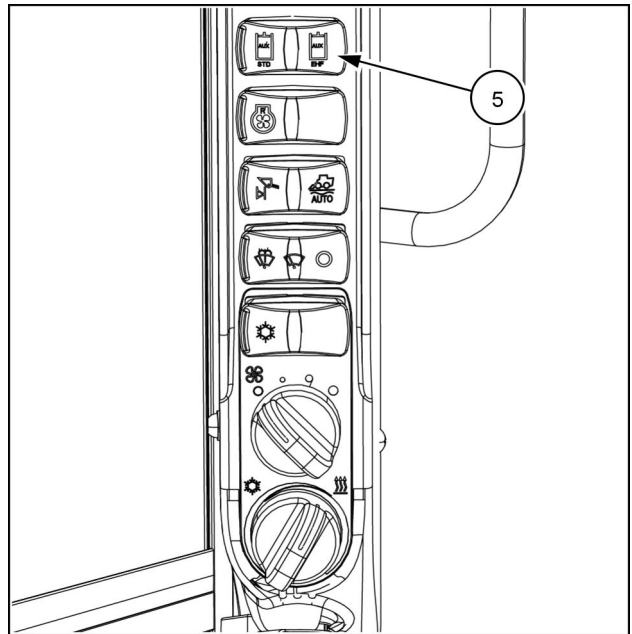

Relieve pressure before disconnecting the attachment hoses

NOTICE: Before removing attachments, make sure that you relieve pressure from the hydraulic system **BEFORE** disconnecting the auxiliary hoses. If the pressure is not relieved, you **WILL NOT** be able to reattach hoses.

1. Lower the loader arm all the way down and ensure that the loader arm or attachment is not supporting the weight of the machine with the front wheels off the ground.
2. Place all controls in the neutral position.
3. Press the Operate button to deactivate the hydraulic system and ground drive system.
4. Stop the engine.
5. Move the controls to ensure that the hydraulic interlock is engaged and the loader arm and bucket cylinders do not move.
6. Unfasten the seat belt and safely exit the machine.
7. Disconnect the electrical connector and install the cap.
8. Prior to disconnecting the attachment hoses, grab the hose connected to the female coupling and push it toward the Connect-Under-Pressure (CUP) valve. When done properly, the coupling will move about **10 mm (0.4 in)**, relieving the stored pressure.
9. Perform the same action for the 3/4 inch male quick disconnect coupling (**2**).
10. Disconnect the attachment hydraulic hoses from the Connect-Under-Pressure (CUP) valve quick disconnects.
11. Install the coupler covers, if equipped.

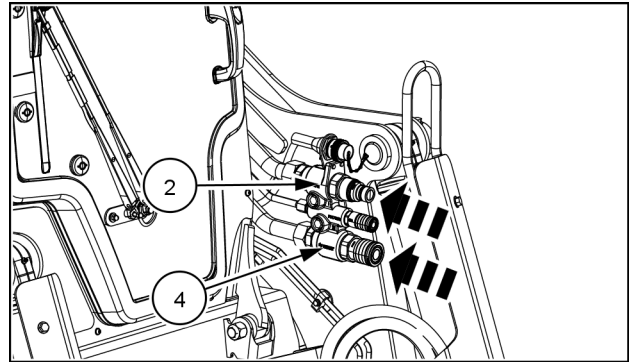

RAIL21SSL0709AA 3