

CX18D



## MINI EXCAVATORS D-Series



Engine 3TNV70

Engine power 12 kW - 16.3 hp

Operating weight with canopy 1830 kg

Operating weight with cab 1940 kg

# SPECIFICATIONS

## CX18D

### ENGINE

Type \_\_\_\_\_ YANMAR 3TNV70 - STAGE 5  
 Max. Power (2.200 rpm) (kW / hp) \_\_\_\_\_ 12 - 16.3  
 Displacement (cm<sup>3</sup>) \_\_\_\_\_ 854  
 Number of cylinders (n°) \_\_\_\_\_ 3  
 Cooling \_\_\_\_\_ Liquid  
 Consumption (l/h) \_\_\_\_\_ 2.4  
 Alternator (V) \_\_\_\_\_ 12 (40 A)  
 Battery V (Ah) \_\_\_\_\_ 12 (65)

### HYDRAULIC SYSTEM

Pump type \_\_\_\_\_ variable flow  
 Pump displacement (cm<sup>3</sup>) \_\_\_\_\_ 8 + 8 + 6.6  
 Pump capacity (l/min) \_\_\_\_\_ 16 + 16 + 13.1  
 Max. circuit calibration pressure (bar) \_\_\_\_\_ 220  
 Auxiliary system (max pressure):  
 AUX 1 single or double effect (l/min) \_\_\_\_\_ 29.1 - 205 bar  
 AUX 2 - optional (l/min) \_\_\_\_\_ 13,1 - 205 bar  
 AUX 3 - optional (l/min) \_\_\_\_\_ 16 - 220 bar

### SLEWING & TRAVEL SPEED

Travelling speed  
 (AUTO TWO SPEED) (km/h) \_\_\_\_\_ 1<sup>st</sup> : 0 ÷ 2.2 / 2<sup>nd</sup> : 0 ÷ 4.1  
 Slew speed (rpm) \_\_\_\_\_ 10.5

### CONTROLS

Boom, dipper stick, bucket and turret swing \_\_\_\_\_ 2 pilot joysticks  
 Track movements (included counter rotation) \_\_\_\_\_ 2 mechanical levers  
 Dozer blade \_\_\_\_\_ pilot lever  
 Auxiliary system AUX 1 (single or double effect) \_\_\_\_\_ right pedal  
 Boom swing \_\_\_\_\_ left pedal

### WEIGHTS

Transport weight with canopy\* (kg) \_\_\_\_\_ 1720  
 Transport weight with cab\* (kg) \_\_\_\_\_ 1830  
 Operating weight with canopy\* ISO 6016 (kg) \_\_\_\_\_ 1830  
 Operating weight with cab\* ISO 6016 (kg) \_\_\_\_\_ 1940  
 \*with rubber tracks

### CIRCUIT AND COMPONENT CAPACITIES

Fuel tank (l) \_\_\_\_\_ 25  
 Hydraulic oil tank (l) \_\_\_\_\_ 20  
 Hydraulic circuit capacity (l) \_\_\_\_\_ 29  
 Cooling system capacity (l) \_\_\_\_\_ 4.5  
 Engine oil (l) \_\_\_\_\_ 2.4

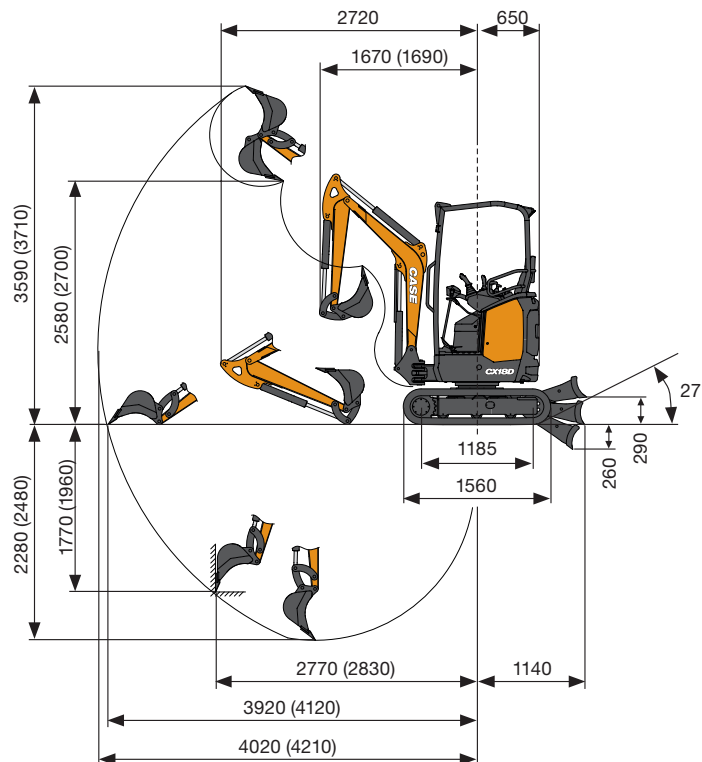

PERFORMANCE DATA		Std. Arm 1150 mm	Opt. Arm 1350 mm
Max. digging depth	mm	2280	2480
Max. dumping height	mm	2580	2700
Bucket breaking force	daN		1500
Arm breaking force ISO 6015	daN		950
Traction force	daN		1700
Ground bearing pressure with rubber tracks and canopy (with cabin)	kg/cm <sup>2</sup>		0.30 (0.31)
Max. slope			60% - 30°

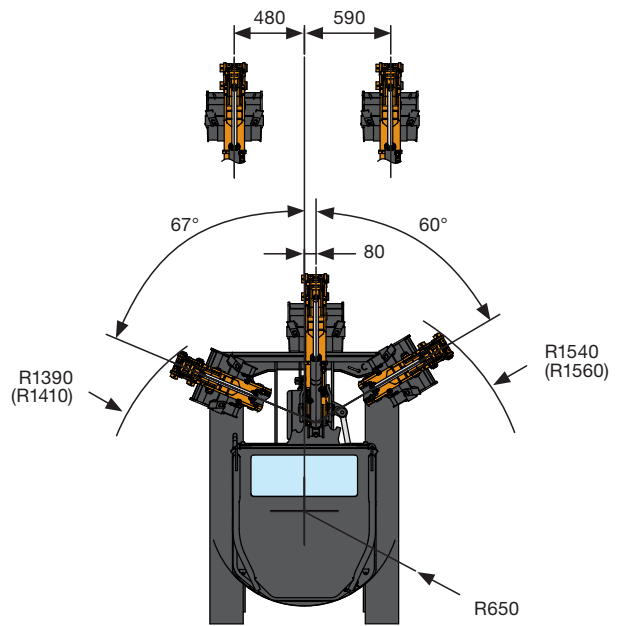
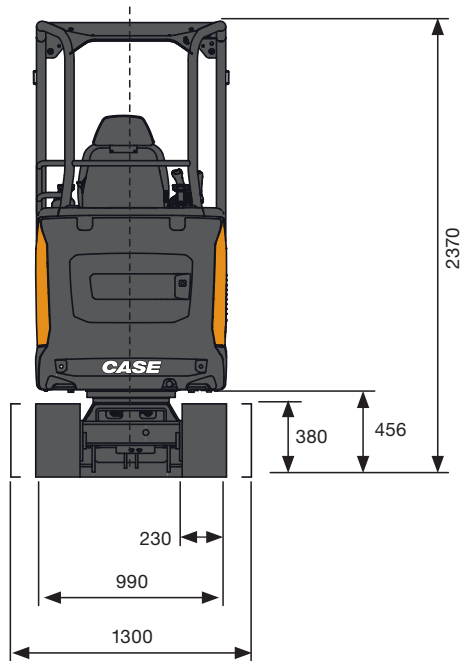

#### GENERAL DIMENSIONS

Maximum width	mm	990 - 1300
Total height	mm	2370
Tracks width	mm	230
Rear rotation radius	mm	650
Digging arm length standard (optional)	mm	1150 (1350)
Rollers number (for each side)	n°	3

## LIFTING CAPACITY

### CX18D

Standard dipper stick L = 1.150 mm  
(Optional dipper stick L = 1.350 mm)

Opening arm from the rotation's center (m)  
Lifting capacity (kg) at 1.0 m height

LIFTING CAPACITY	2	3	Max
Frontal and lowered dozer blade	610*	420*	390*
Frontal and lifted dozer blade	420	230	180
Lateral, open undercarriage	420	230	180

\* Indicates the hydraulic load limit.

The lifting capacity is based on the ISO 10567 and it does not exceed more than the 75% of static tipping load or more than the 87% of the hydraulic lifting capacity of the machine.

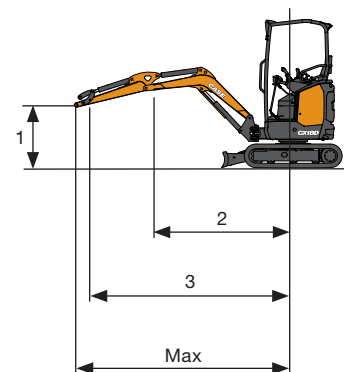

# STANDARD AND OPTIONS

## STANDARD EQUIPMENT

- + Tilttable Cab/Canopy (ROPS/TOPS - FOPS Level 1)
- + Heating
- + Automatic Courtesy light
- + Electric plug on the roof for Rotating Beacon
- + Windshield washer
- + Rear-view mirrors (left, right)
- + Fabric seat with Mechanical suspension (cab)
- + Vinyl seat with Mechanical suspension (canopy)
- + Standard arm
- + Boom Lift cylinder and dozer blade cylinder protection
- + Standard counterweight
- + Pedal Swing control
- + 1<sup>st</sup> Auxiliary (AUX1) circuit with Pedal control
- + AUX1 circuit maximum flow mechanical setting
- + Mechanical diverter between Single effect and Double effect AUX1
- + 2 speed travel with Automatic Shift Down (from 2<sup>nd</sup> to 1<sup>st</sup> gear if more traction is required) and Shift-up
- + Rubber tracks
- + Standard Dozer Blade
- + Extendable undercarriage
- + Operator manual
- + Ignition key, which opens every machine lock
- + Standard LED working lights (boom)
- + Battery disconnect switch
- + Variable Volume Pump
- + Standard Hydraulic oil and Lubricants

## OPTIONAL EQUIPMENT

- + DAB Radio, Bluetooth, USB, Aux-in (cab only)
- + Anti-Theft
- + Travel alarm
- + Long arm
- + Additional counterweight
- + 2<sup>nd</sup> Auxiliary (AUX2) circuit with Pedal control and flow diverter from boom swing
- + Grapple provision (AUX3 with flow diverter from bucket cylinder)
- + Direct Drainage to tank
- + Block valves on dozer blade cylinder
- + Object handling kit (block valves on boom and arm, lifting hook and load chart)
- + Extra LED working lights (cab-front and cab-rear)
- + Rotating beacon
- + CASE Sitewatch and SiteConnect
- + Bio Hydraulic oil and Lubricants
- + Hydraulic quick coupler provision (Single or Double Effect)
- + Mechanical and Hydraulic quick couplers
- + Buckets

## CASE AFTERMARKET SOLUTIONS

- + Front Protection grid (Level 2)
- + Arm cylinder and bucket cylinder protection
- + Vast variety of attachments
- + Full range of Mechanical and Hydraulic quick couplers
- + Full range of Buckets

**CNH Industrial**  
Deutschland GmbH  
Case Baumaschinen  
Benzstr. 1-3 - D-74076 Heilbronn  
DEUTSCHLAND

**CNH Industrial**  
Maquinaria Spain, S.A.  
Avenida Aragón 402  
28022 Madrid - ESPAÑA

**CNH Industrial France, S.A.**  
16-18 Rue des Rochettes  
91150 Morigny-Champigny  
FRANCE

**CNH Industrial Italia Spa**  
Lungo Stura Lazio 19  
10156, Torino  
ITALIA

**CASE Construction Equipment**  
Cranes Farm Rd  
Basildon - SS14 3AD  
UNITED KINGDOM

NOTE: Standard and optional fittings can vary according to the demands and specific regulations of each country. The illustrations may include optional rather than standard fittings - consult your Case dealer. Furthermore, CNH Industrial reserves the right to modify machine specifications without incurring any obligation relating to such changes.

Conforms to directive 2006/42/EC

**CASECE.COM**  
**00800-2273-7373**

The call is free from a land line.  
Check in advance with your Mobile Operator if you will be charged. Toll free number not available from all calling areas.